

Design data	
Vessel category	Normal pressure
Description of parameter	Vessel
Working pressure	psi ATMP
Design pressure	psi ATMP
Level testing pressure	psi ATMP
Medium	Water
Material	SUS 304
Working temperature	°F 15 to 250
Design temperature	°F 15 to 250
Gross volume	BBL 60
Net volume	BBL 50
Heat exchanger area	m2 -----
Glycol Jacket Max Volume	Gallon -----
Insulation material	Rock wool
Insulation thickness	mm 100
Total Tank Weight Empty	lbs 3270
Total Tank Weight Full	lbs 16200

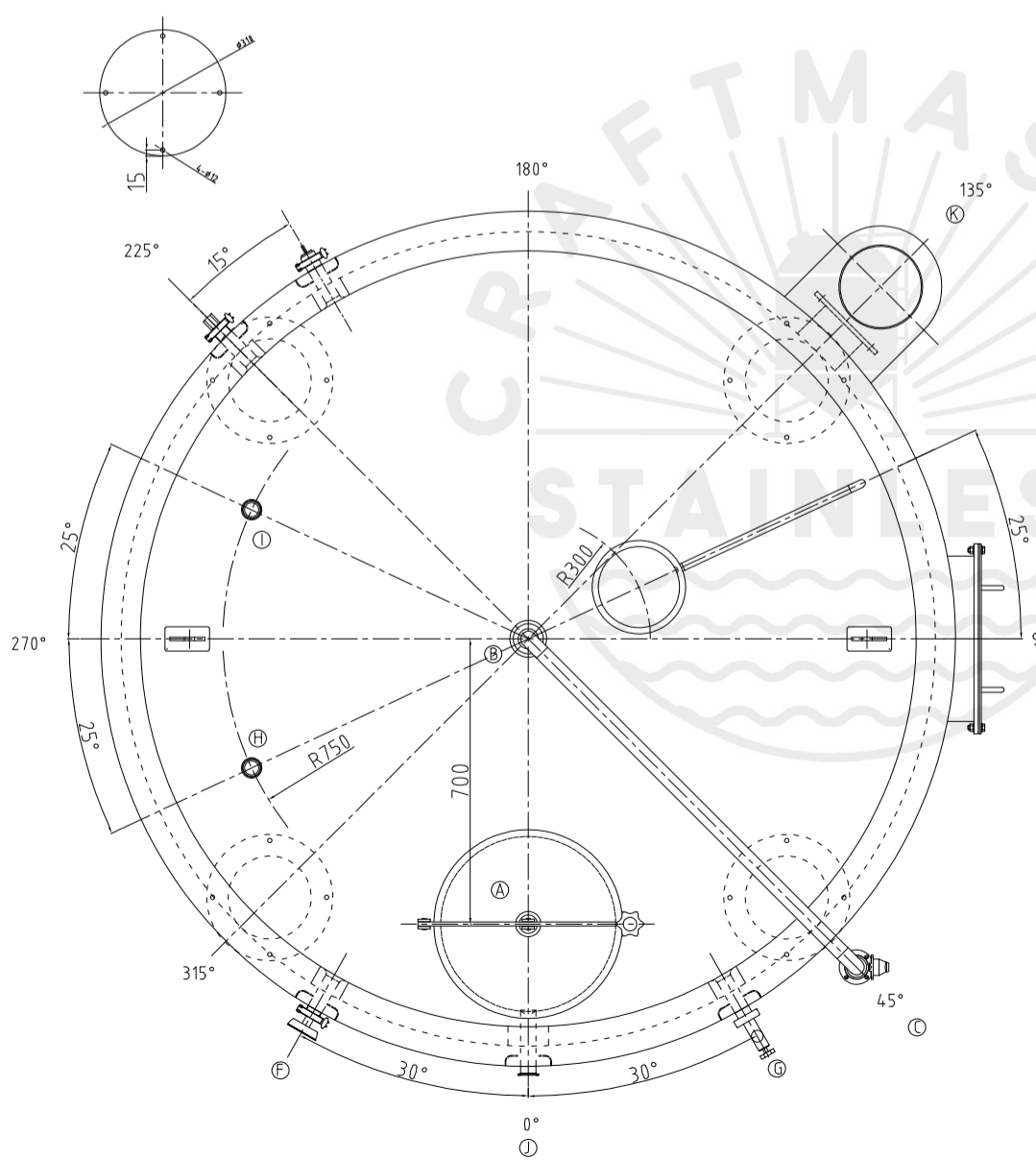
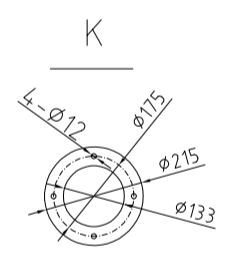
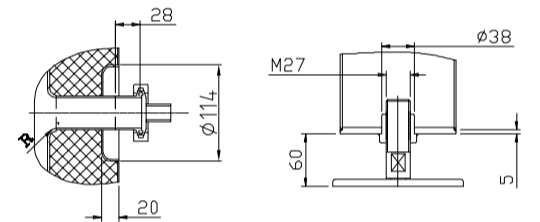
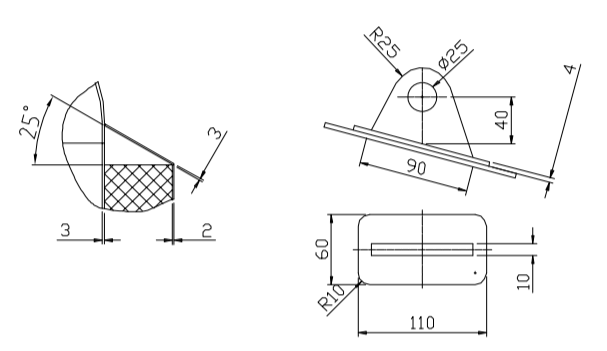

CONNECTIONS				
MARK	DN	DESCRIPTION	CONNECT SIZE	REMARKS
A	Ø17"	Manway	Ø17"	ISO
B	3"	PORT	3"	ISO
C	1.5"	CIP APM FERRULE	1.5"	ISO
D	1.5"	TEMPERATURE CONN	1.5"	ISO
E	Ø4.25"	EXHAUST CAP	Ø4.25"	ISO
F	1.5"	TEM-GAGE	1.5"	ISO
G	1.5"	LEVEL GAGE	1.5"	ISO
H	1.5"	INLET	1.5"	ISO
I	1.5"	INLET	1.5"	ISO
J	1.5"	OUTLET	1.5"	ISO
K	Ø5.2"	Burner flange	Ø5.2"	ISO
N	1.5"	Anti Dry Burning Sensor	1.5"	ISO

	11/11/2022
	50BBL HLT(FIRED)