

Design data

Vessel category	Normal pressure	
	Vessel	Jacket
Description of parameter	Vessel	Jacket
Working pressure psi	ATMP	45
Design pressure psi	ATMP	45
Level testing pressure psi	ATMP	75
Medium	Water	Glycol
Material	SUS 304	SUS 304
Working temperature °F	15 to 250	
Design temperature °F	15 to 250	
Gross volume BBL	36.2	
Net volume BBL	30	
Heat exchanger area m ²	7.5	
Glycol Jacket Max Volume Gallon	10	
Insulation material	Chloride Free Polyurethane	
Insulation thickness mm	80	
Total Tank Weight Empty lbs	1650	
Total Tank Weight Full lbs	9400	

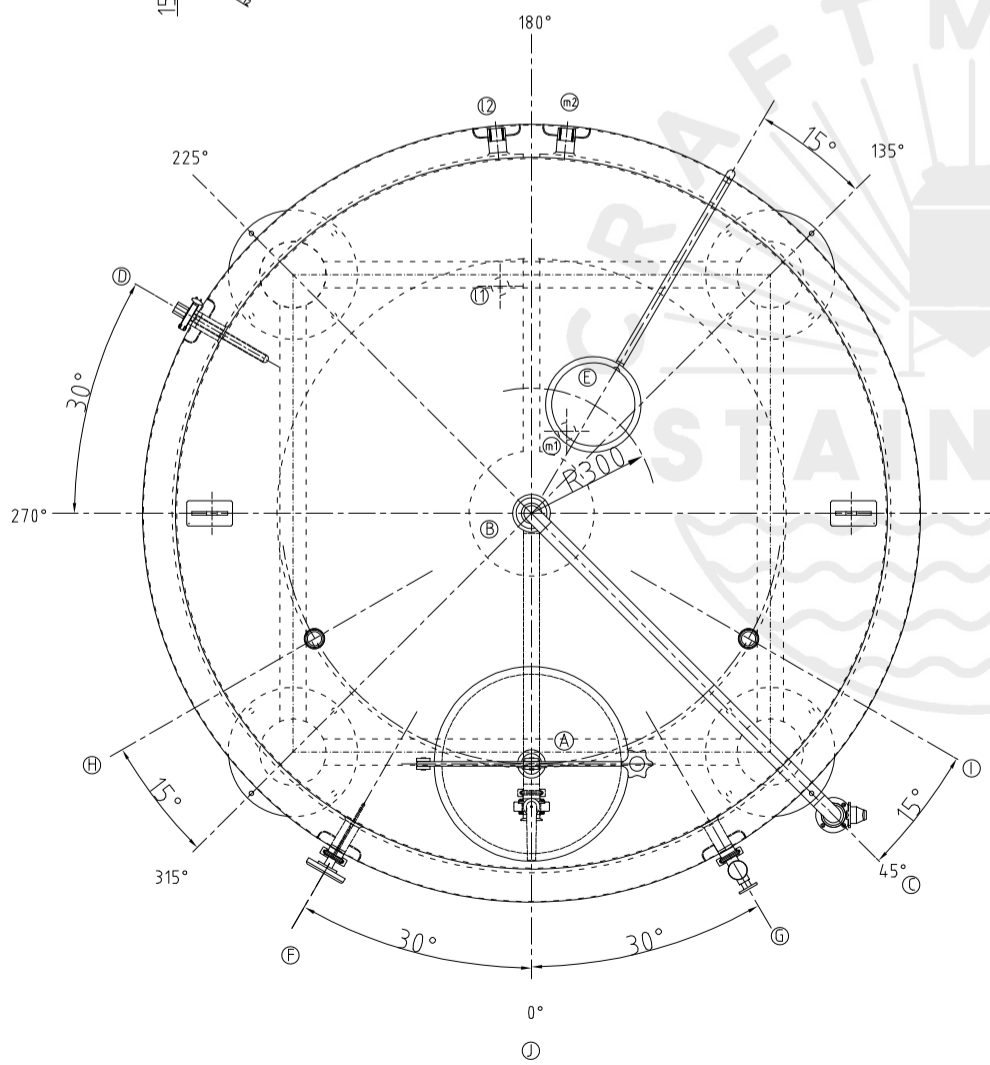
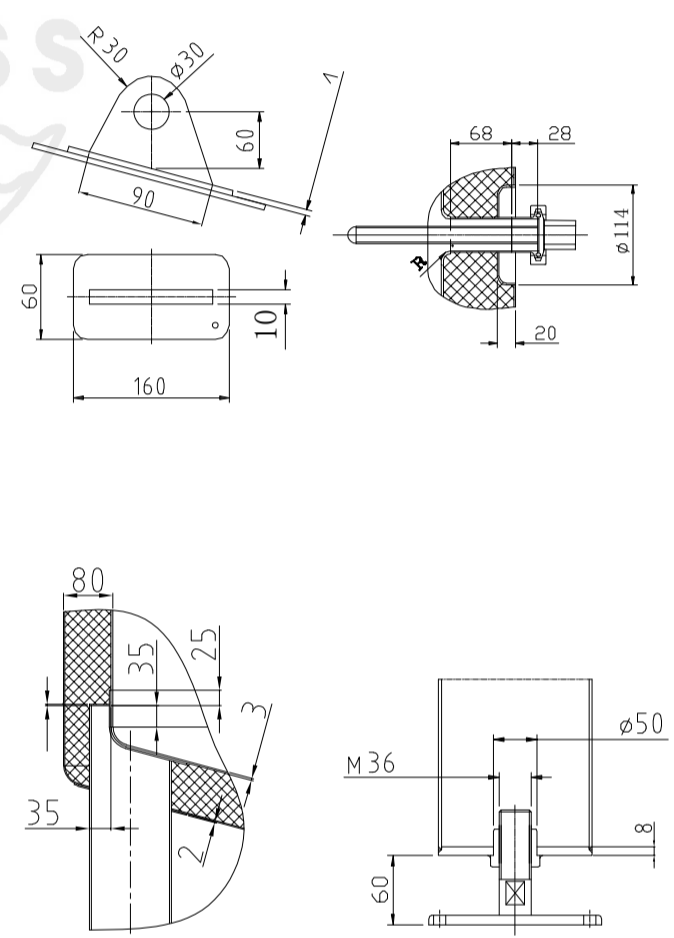
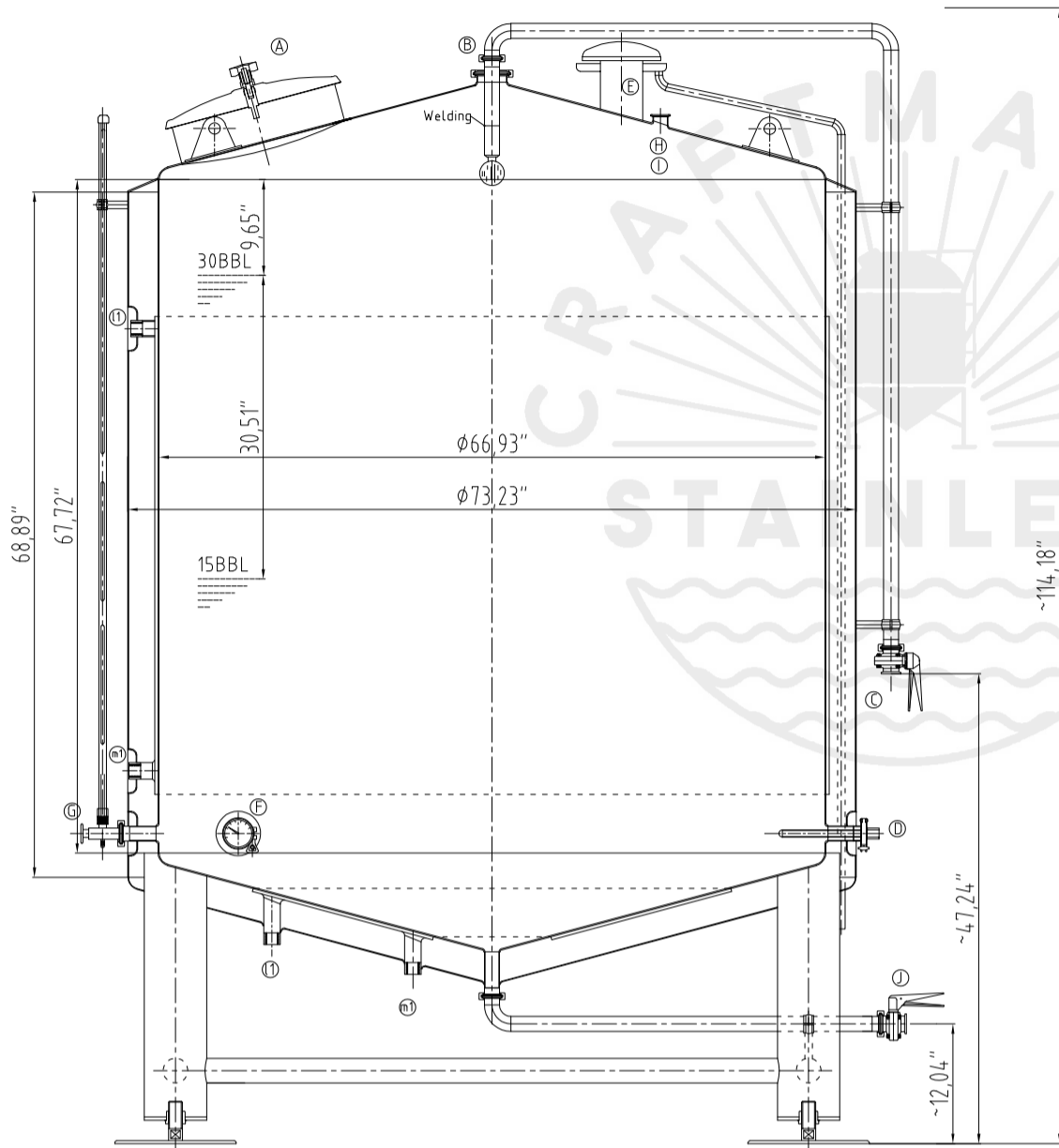

CONNECTIONS

MARK	DN	DESCRIPTION	CONNECT SIZE	REMARKS
A	φ17"	MANWAY	φ17"	ISO
B	3"	PORT	3"	ISO
C	1.5"	CIP APM FERRULE	1.5"	ISO
D	1.5"	TEMPERATURE CONN	1.5"	ISO
E	φ4.25"	EXHAUST CAP	φ4.25"	ISO
F	1.5"	TEM-GAGE	1.5"	ISO
G	1.5"	LEVEL GAGE	1.5"	ISO
H	1.5"	INLET	1.5"	ISO
I	1.5"	INLET	1.5"	ISO
J	1.5"	OUTLET	1.5"	ISO
l	3/4"	Glycol OUTLET	3/4"	NPT
m	3/4"	Glycol INLET	3/4"	NPT



10/10/2022

30BBL CLT