



**ORGANIZING AUTHORITY:
ROYAL YACHT SQUADRON**
in association with the
BRITISH CLASSIC YACHT CLUB
17 - 21 JULY 2023
COWES

INTERNATIONAL 6M CLASS SAILING INSTRUCTIONS

The notation '[DP]' in a rule in the Sailing Instructions means that the penalty for a breach of that rule may, at the discretion of the protest committee, be less than disqualification.

1. RULES

- 1.1 See Notice of Race 1.

2. CHANGES TO SAILING INSTRUCTIONS

- 2.1 Any change to the Sailing Instructions (SIs) made ashore will be posted by 0900 on the day it will take effect, except that any change to the schedule of races will be posted by 2000 on the day before it will take effect.

3. COMMUNICATIONS WITH COMPETITORS

- 3.1 Notices to competitors will be posted on the Official Notice Board (ONB). The ONB will be online at www.rys.org.uk.
- 3.2 The Race Committee (RC) intends to broadcast race information and course information by VHF Ch 05 and repeated on the Event Telegram group. See Addendum B.
- 3.3 On each racing day, the RC will provide a morning briefing by VHF and Telegram at 0900.
- 3.4 Competitors wishing to communicate with the RC should do so on VHF Ch 77.

4. CODE OF CONDUCT

- 4.1 Competitors and support persons shall comply with reasonable requests from race officials.

5. SIGNALS MADE ASHORE AND AFLOAT

- 5.1 Signals made ashore will be displayed at the RYS Flagstaff and advised on the event Telegram group.
- 5.2 When flag AP is displayed ashore, "1 minute" is replaced by "not less than 45 minutes". This changes Race Signals AP.

6. SCHEDULE

- 6.1 See Notice of Race 9.

7. CLASS FLAGS

The class flag is shown below.

Open Division	Naval Numeral Two 
Classic Division	Naval Numeral 6 

8. RACING AREA

- 8.1 Racing will take place from a Committee Vessel (CV) in the Central and Eastern Solent.

9. COURSES

- 9.1 The courses to be sailed will be a windward / leeward configuration as described in Addendum A.
- 9.2 If only a single windward or leeward mark is present, boats shall leave that mark to port before proceeding to the next mark of the course.
- 9.3 Soon after the orange flag attention signal is displayed, and before the warning signal, the RC signal vessel will display the approximate bearing and distance to Mark 1. The course signal, compass bearing and distance to Mark 1 will also be announced on VHF.
- 9.4 In cross-tide wind conditions, after the first leg, subsequent legs of the course may be 'walked' down tide to achieve reasonable leeward or windward legs.
- (a) Flag W will be displayed at or before the warning signal for a race where the course will be 'walked' down tide.
- (b) When flag W has been displayed, no course changes (using flag C) or new marks will be used except when the leg length is being increased or decreased or the course is changed for a wind shift. This changes RRS Race Signals and RRS 33.

10. MARKS

- 10.1 With reference to Addendum A, marks 1, 1a, 4s & 4p will be orange inflatable marks.
- 10.2 The starting mark and the finishing mark will be a black inflatable mark.
- 10.3 Change marks will be black marks.
- 10.4 A RC vessel positioned near a mark may display a flag showing the colour of the next mark, except for the final leg to the finish line.

11. OBSTRUCTIONS

- 11.1 All yachts shall comply with [Associated British Ports Notice to Mariners No 06 of 2023](#) giving details of a Precautionary Area and Moving Prohibited Zone (MPZ). The MPZ shall rank as an obstruction for the purposes of RRS 19 and 20.
- 11.2 Any official boat in close attendance to a craft in difficulty is an obstruction.

12. THE START

- 12.1 The start line is between a staff displaying an orange flag on the CV and the course side of the starting mark.
- 12.2 If any part of a boat's hull is on the course side of the starting line at her starting signal and she is identified, the RC will attempt to broadcast her sail number on VHF Ch 05.
- 12.3 A boat that does not start within five (5) minutes after her starting signal will be scored Did Not Start without a hearing. This changes RRS A5.1 and A5.2.

All correspondence should be directed to:

BRITISH CLASSIC WEEK Regatta Office

c/o Mary Scott-Jackson, **MSJ Events**, Regatta House, 18 Bath Road, Cowes PO31 7QN. Tel: 01983 245100, Email: mary@msjevents.co.uk

13. CHANGE OF THE NEXT LEG OF THE COURSE

- 13.1 When a change of the next leg of the course has been signalled, the RC will lay a new mark (or move the finishing line) and remove the original mark as soon as practicable. When in a subsequent change a new mark is replaced, it will be replaced by an original mark.
- 13.2 The RC may announce details of any change under SI 13.1 using VHF Ch 05.
- 13.3 The position of any mark(s) may be adjusted by up to plus or minus 10 degrees relative to previous location and up to approximately 200 metres to windward or leeward without signalling Flag C, a direction signal, a length signal, a sound signal or announcement using VHF. This changes RRS 33.

14. THE FINISH

- 14.1 The finishing line is between a staff displaying a blue flag on the CV and the course side of the finishing mark.

15. PENALTY SYSTEM

- 15.1 See Notice of Race 14.

16. TIME LIMITS

- 16.1 The Mark 1 Time Limit, Race Time Limit (see RRS 35), Finishing Window and the Target Time are shown in the table below.

Mark 1 Time Limit	Race Time Limit	Finishing Window	Target Race Time
Open Division 50 mins. Classic Division 60 mins.	150 mins	30 mins	75 mins

- 16.2 If no boat has passed the first mark within the Mark 1 Time Limit, or if no boat has finished within the Race Time Limit, the race will be abandoned.
- 16.3 The Finishing Window is the time for boats to finish after the first boat sails the course and finishes. Boats failing to finish within the Finishing Window, and not subsequently retiring, penalized or given redress, will be scored TLE without a hearing. A boat scored TLE shall be scored points for the finishing place two more than the points scored by the last boat that finished within the Finishing Window. This changes RRS 35, A5.1, A5.2 and A10.
- 16.4 Failure to meet the Target Race Time will not be grounds for redress. This changes RRS 62.1(a)).

17. HEARING REQUESTS

- 17.1 The protest limit is 90 minutes after the last boat in their division has finished the last race of the day or the RC signals no more racing today, whichever is later. This time will be posted on the ONB.
- 17.2 Hearing request forms will be available from the Race Office at Cowes Yacht Haven (CYH).
- 17.3 Contact mobile phone numbers should be included on the protest form.
- 17.4 Notices will be posted no later than 30 minutes after the protest time limit to inform competitors of the hearings in which they are parties or named as witnesses.
- 17.5 Hearings will be held in the protest room located at the CYH, beginning at the time posted.

18. SCORING

- 18.1 See Notice of Race 15.

19. SAFETY REGULATIONS

- 19.1 [DP] A boat that retires from a race shall notify the Race Committee as soon as possible on VHF Ch 77 or by hailing an official regatta support boat or RIB.

20. REPLACEMENT OF CREW OR EQUIPMENT

- 20.1 Substitution of competitors is not allowed without the prior written permission of the RC.
- 20.2 Substitution of damaged or lost equipment is not allowed unless authorised in writing by the RC. Requests for substitution shall be made to the RC at the first reasonable opportunity, which may be after the race.

21. EQUIPMENT AND MEASUREMENT CHECKS

- 21.1 A boat or equipment may be inspected at any time.

22. SUPPLIED BOATS

- 22.1 Not used.

23. OFFICIAL VESSELS

- 23.1 Mark laying vessels will be RYS RIBs.
- 23.2 The CV will be a 10m blue hulled motor catamaran – Call Sign Castle Two.

24. SUPPORT PERSON VESSELS

- 24.1 See Notice of Race 16.

25. TRASH

- 25.1 Trash may be placed aboard official or support person vessels.

26. BERTHING

- 26.1 See Notice of Race 18.

27. HAUL OUT RESTRICTIONS

- 27.1 See Notice of Race 19.

28. DIVING EQUIPMENT AND PLASTIC POOLS

- 28.1 See Notice of Race 20.

29. PRIZES

- 29.1 See Notice of Race 24.



30. RISK STATEMENT

- 30.1 See Notice of Race 22.

31. INSURANCE

- 31.1 See Notice of Race 23.

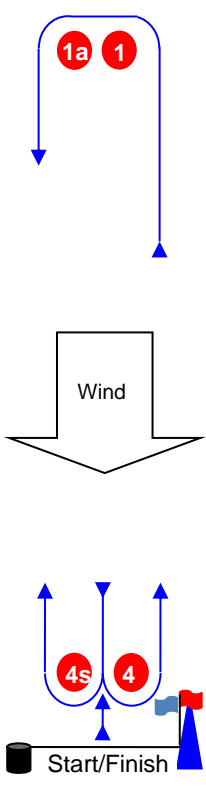
ADDENDUM A – Course configuration.

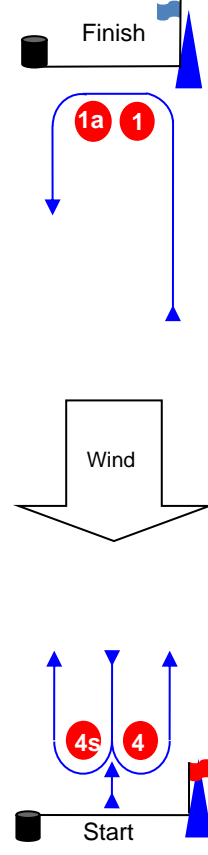
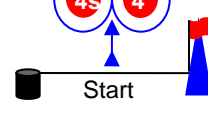
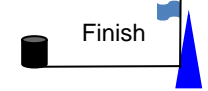
Course Illustrations – Windward Leeward																			
<div style="font-size: 2em; font-weight: bold; margin-bottom: 20px;">LA</div>  <div style="text-align: center; margin-top: 20px;">  <p>Start/Finish</p> </div>	<div style="font-size: 2em; font-weight: bold; margin-bottom: 20px;">WA</div>  <div style="text-align: center; margin-top: 20px;">  <p>Start</p> </div> <div style="text-align: center; margin-top: 20px;">  <p>Finish</p> </div>																		
<p>Course: Leeward finish</p> <table style="width: 100%; border-collapse: collapse;"> <thead> <tr> <th style="text-align: left; width: 10%;">Signal</th> <th style="text-align: left;">Mark Rounding Order</th> </tr> </thead> <tbody> <tr> <td>LA 1</td> <td>Start – 1 – 1a – Finish.</td> </tr> <tr> <td>LA 2</td> <td>Start – 1 – 1a – 4s/4p – 1 – 1a – Finish</td> </tr> <tr> <td>LA 3</td> <td>Start – 1 – 1a – 4s/4p – 1 – 1a – 4s/4p – 1 – 1a – Finish.</td> </tr> <tr> <td>LA 4</td> <td>Start – 1 – 1a – 4s/4p – 1 – 1a – 4s/4p – 1 – 1a – 4s/4p – 1 – 1a – Finish.</td> </tr> </tbody> </table>	Signal	Mark Rounding Order	LA 1	Start – 1 – 1a – Finish.	LA 2	Start – 1 – 1a – 4s/4p – 1 – 1a – Finish	LA 3	Start – 1 – 1a – 4s/4p – 1 – 1a – 4s/4p – 1 – 1a – Finish.	LA 4	Start – 1 – 1a – 4s/4p – 1 – 1a – 4s/4p – 1 – 1a – 4s/4p – 1 – 1a – Finish.	<p>Course: Windward Finish</p> <table style="width: 100%; border-collapse: collapse;"> <thead> <tr> <th style="text-align: left; width: 10%;">Signal</th> <th style="text-align: left;">Mark Rounding Order</th> </tr> </thead> <tbody> <tr> <td>WA 1</td> <td>Start – 1 – 1a – 4s/4p – Finish</td> </tr> <tr> <td>WA 2</td> <td>Start – 1 – 1a – 4s/4p – 1 – 1a – 4s/4p – Finish.</td> </tr> <tr> <td>WA 3</td> <td>Start – 1 – 1a – 4s/4p – 1 – 1a – 4s/4p – 1 – 1a – 4s/4p – Finish.</td> </tr> </tbody> </table>	Signal	Mark Rounding Order	WA 1	Start – 1 – 1a – 4s/4p – Finish	WA 2	Start – 1 – 1a – 4s/4p – 1 – 1a – 4s/4p – Finish.	WA 3	Start – 1 – 1a – 4s/4p – 1 – 1a – 4s/4p – 1 – 1a – 4s/4p – Finish.
Signal	Mark Rounding Order																		
LA 1	Start – 1 – 1a – Finish.																		
LA 2	Start – 1 – 1a – 4s/4p – 1 – 1a – Finish																		
LA 3	Start – 1 – 1a – 4s/4p – 1 – 1a – 4s/4p – 1 – 1a – Finish.																		
LA 4	Start – 1 – 1a – 4s/4p – 1 – 1a – 4s/4p – 1 – 1a – 4s/4p – 1 – 1a – Finish.																		
Signal	Mark Rounding Order																		
WA 1	Start – 1 – 1a – 4s/4p – Finish																		
WA 2	Start – 1 – 1a – 4s/4p – 1 – 1a – 4s/4p – Finish.																		
WA 3	Start – 1 – 1a – 4s/4p – 1 – 1a – 4s/4p – 1 – 1a – 4s/4p – Finish.																		

ADDENDUM B – Telegram Instructions.



Telegram

We have set up an official [Telegram](#) group for receiving general information from the Race Office and Race Committee.

If you do not already have the Telegram app installed on your device, please follow the instructions below:

- **Apple iPhones** – download and install via the App Store.
<https://apps.apple.com/app/telegram-messenger/id686449807>
- **Android Phones** – download and install via the Google Play Store.
<https://play.google.com/store/apps/details?id=org.telegram.messenger>

To join the Telegram group please use either the link or the QR code below:

LINK: <https://t.me/+wWeMY6hIj4lxYzq0>

QR Code:

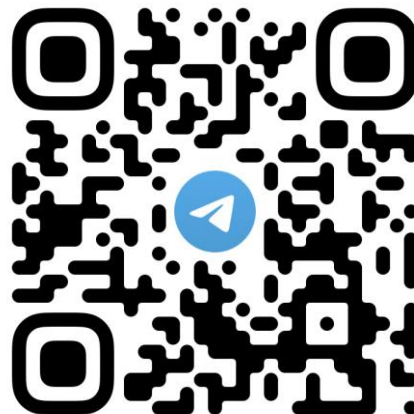

All correspondence should be directed to:

BRITISH CLASSIC WEEK Regatta Office

c/o Mary Scott-Jackson, **MSJ Events**, Regatta House, 18 Bath Road, Cowes PO31 7QN. Tel: 01983 245100, Email: mary@msjevents.co.uk