



Your Local Southern Cali BRC Rep:

Sheila Shenasi, IIDA



INFINITY
CONTRACT RESOURCES

C: (310) 920-0704

Sheila@INFINITYcontract.net

Introduction

- Founded in 1983 in Georgetown, Ontario, CA
- Core competencies: laminate casegoods and custom solutions
- Known for entrepreneurial spirit and environmental focus
- High production/quality machinery including laser edging
- Storage and Private Office portfolios



Why Choose BRC?



Product Leadership

High-quality office furniture.
Provides a tailored full office solution.
BIFMA Level[®] 2 certified.



Customer Focused

Build long-term relationships with clients. Prompt communication and great lead times.
12-year standard warranty.



Sustainable Operations

Focused on delivering sustainable office solutions. Blending with a BRC solution reduces the typical suite 20% to 30%



Competitive Pricing

Offers a competitive pricing structure. Fast turnaround times for quotes.

OUR COMMITMENT TO

SUSTAINABILITY & THE ENVIRONMENT

- We use products and process that reduce VOC.
- Adhesives used are either water based or non-solvent
- For painting of metal components, BRC uses an electrostatic powder coating
- BRC uses wood and wood-based products that have minor formaldehyde emissions
- All BRC products have been designed using ANSI/BIFMA standards.
- BRC has TSCA title 6 compliant products
- BRC is Level[®] 2 Certified

Why Expand the alliance product offering?

- Increased share of dealer wallet
- Consistent finishes/look and feel
- Lower overall costing to clients allow for higher GP in chairs & ancillary
- Win while maintaining discounts
- Standard customs and providing the right solution
- Partnerships HMI/BRC/Dealer = **WIN**



FIL is an exclusive product line for Herman Miller Dealers. It Includes vertical storage elements, low storage, waste cabinets, an extensive locker offering, planter cabinetry and much more.

The FIL storage all has been made with the same attention to quality, design, functionality and material, which has been our hallmark since the beginning.



Product Map

1 2 3

Reception

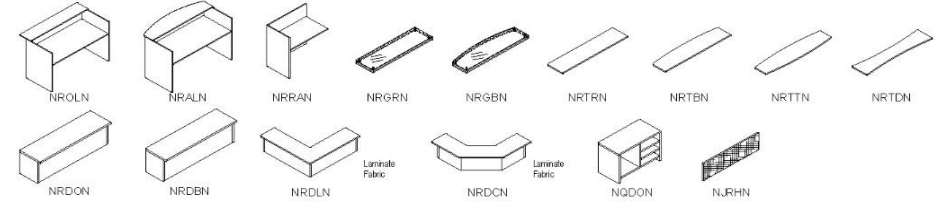

Desks

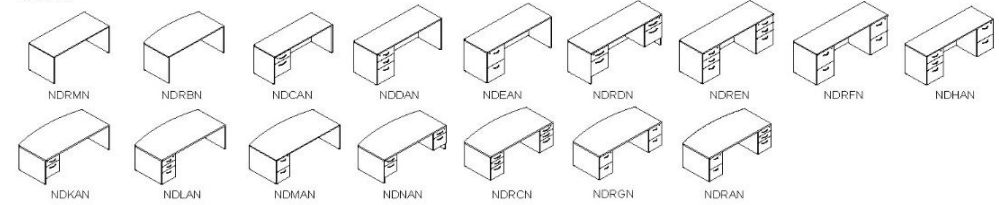

Tables

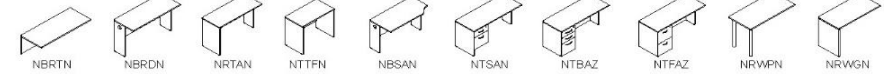

Desk Height Credenzas

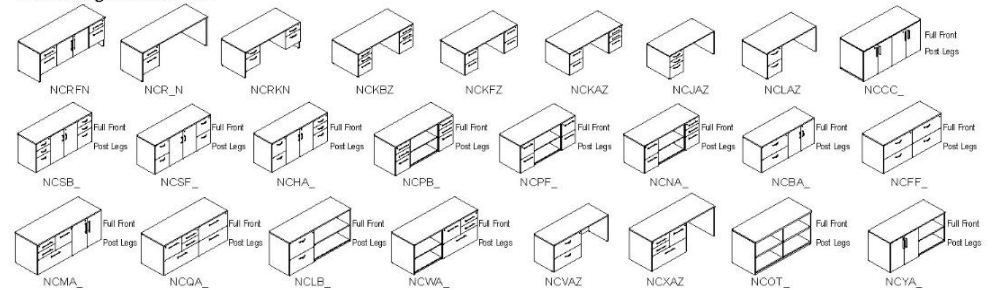

Low Credenzas

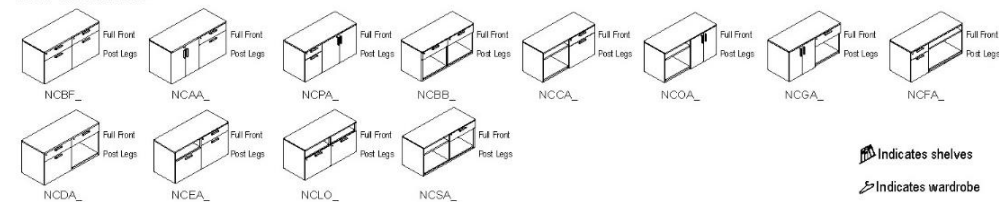

Low Storage Add-ons

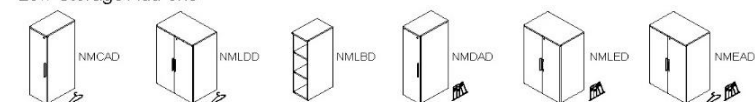

Indicates shelves
 Indicates wardrobe

Product Map

1 2 3

Tables

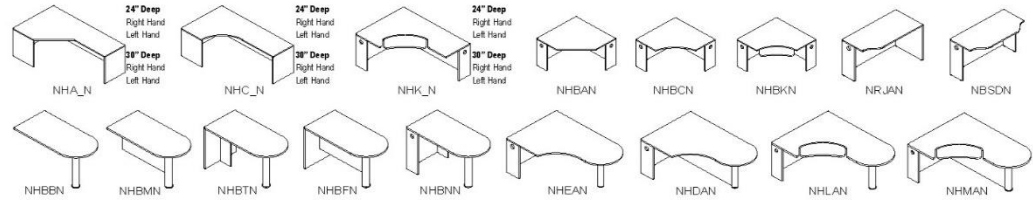

Mobile Pedestals



Undermount Pedestals

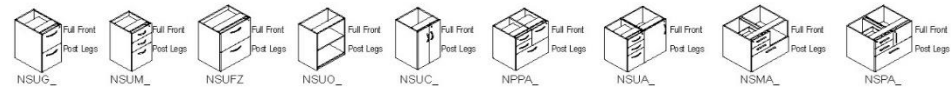

Accessories

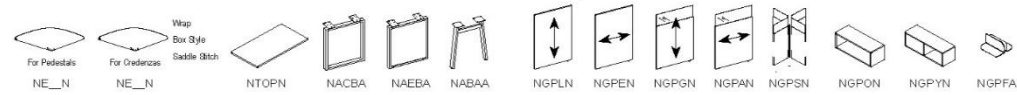

Gallery Panels

INTRODUCTION APPLICATION STORAGE

Wall Mounted Storage

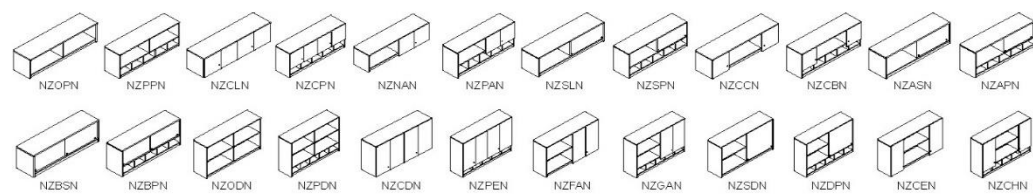

Desk Hutches

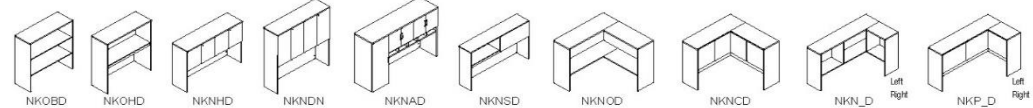

Filing



Standalone Desk Height Storage

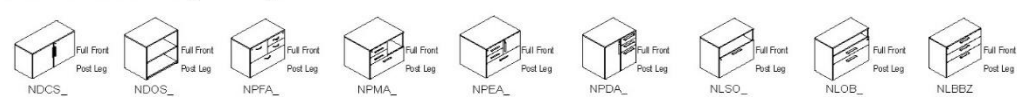

Product Map

1 2 3

Low Storage, No Top

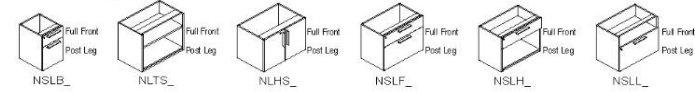

Low Storage



Tall Storage

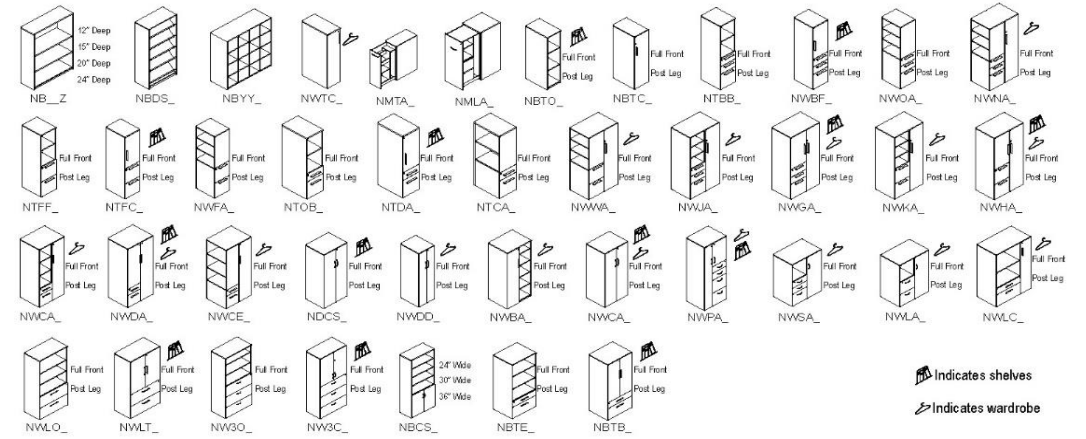

Indicates shelves
Indicates wardrobe

Study Carrels

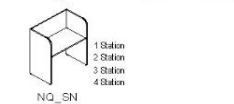

Conference

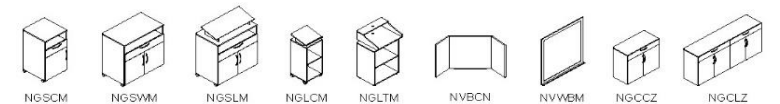

Waste Cabinets

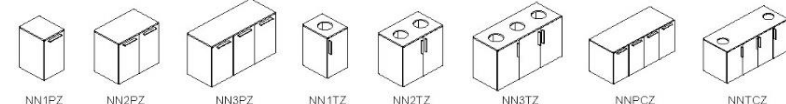

Integrated Credenzas

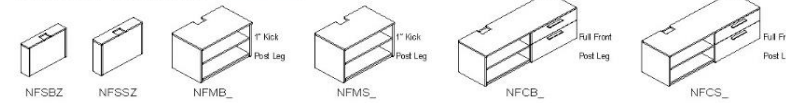

Planter Top



Discount and Lead-Times

USA List Price		Discounting Percentage			
From	To	Fil Series	Tables	Accessories	Height Adjustable
\$ 1.00	\$ 5,000.00	-	64%	71%	71%
\$ 5,001.00	\$ 20,000.00	-	66%	72%	72%
\$ 20,001.00	\$ 50,000.00	69%	68%	73%	73%
\$ 50,001.00	\$ 100,000.00	71%	70%	74%	74%
\$ 100,001.00	\$ 250,000.00	73%	72%	75%	75%
Greater Than	\$ 250,001.00	MM Approval	MM Approval	MM Approval	MM Approval

Product	Lead Time
Accessories	2 weeks
Healthcare – Screens (volume sensitive)	3-4 weeks
Height Adjustable Bases only (stock sensitive)	2 weeks
Height Adjustable Tables (LPL)	3 weeks
Height Adjustable Tables (HPL)	5 weeks
Standard BRC Case Goods with Standard Finish	4 weeks
Standard BRC Case Goods with Custom Finish	6 weeks
Custom Case Goods with Standard Finish	7 weeks
Custom Case Goods with Custom Finish	8 weeks

Shipping, Warranty and Mock-up Policy

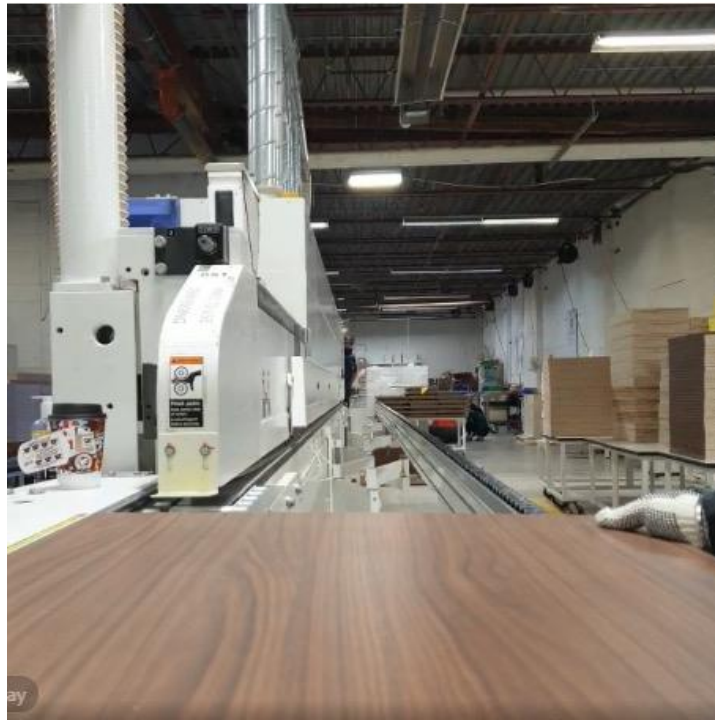

Shipping

- Freight included for orders over territory minimum
- Shipping dock to dock during standard weekday hours
- Orders under territory minimum are subject to freight drop charge

Warranty

- 12-year limited structural warranty
- 5-year warranty on adjustable components
- 1-year warranty on electrical elements

Mock-Up

- Mock-up discount is 75%
- Minimum order value of \$50,000.00
- Dealer must pay full freight
- Mock-up form must be completed
- 10-day turnaround from confirmation, dependant on order complexity



Comparing Laminate Storage		Canvas Wood Storage	Tu Wood Storage	BRC Laminate Storage
When To Use		Best Experience	Great Value	Competitive Bids/ Everyday Great Value
		Private Office Applications	Unique "Lifestyle" Storage	Largest Storage offering w/custom abilities
		Aesthetic Requirements	Support Individual & Group	Support Individual & Group
		Support for a Canvas Wall	Made-to-Measure	Flexible L x W x H + customize to 1/16"
		Route Power Through Storage	Integration w/ Layout Studio	
Construction	Case	LPL, HPL, Veneer	LPL, HPL, Veneer	LPL
	Top & Fronts	LPL, HPL, Veneer	LPL, HPL, Veneer	LPL, HPL
	Alignment	Case/Fronts/Top All Flush	Tops & Fronts Proud of Case	Tops & Fronts Proud of Case
	Base	Plinth (2"), Footed (4")	Plinth, Footed (both 2")	<ul style="list-style-type: none"> - Floor - Recessed Plinth (2"0 - 2.25 Onset (Canvas) - 2" foot (Canvas) - 4" foot (Canvas)
	Connection	Glue & Dowell (case clamp)	Glue & Dowell (case clamp)	Mechanical fastener
	Power	Yes	No	Optional
Technical Specifications	Board Weight	45lbs med density	45lbs med density	45lbs med density
	Board Thickness (Case/Fronts)	3/4"	3/4"	3/4"
	Edge Banding	Polypropylene	Polypropylene	Polypropylene
		On Exposed Edges Only	On Exposed Edges Only	On all edges
Hardware		Slides: box drawers – 100lb rated; file drawers – 200lb rated	Slides: box drawers – 100lb rated; file drawers – 200lb rated	Slides: box drawers – 100lb rated; file drawers – 150lb rated
Environmental Specifications	Indoor Air Quality	Indoor Advantage Gold; BIFMA level 3;	Indoor Advantage Gold; BIFMA level 2	Clean Air, Gold ; BIFMA Level 2
	FSC (HPL Tops Only)	Yes	Yes	Optional/Available
	PVC	None	None	None
Warranty		12-Years / 3 Shift - Comprehensive	12-Years / 3 Shift - Comprehensive	12-Years / 1 Shift - Limited Structural
Dealer Considerations	Freight Charges	Pricing Includes Freight	Pricing Includes Freight	Price includes freight over \$2500 net.
	Specification Support	Limited	Limited	Available

Vendor Competitor Analysis

Item	Size	BRC	National	La Casse	OFS	Global	HMI	Three H	Teknion	AIS	Logiflex	Kimball
			Waveworks	Concept 70	Pulse	Princeton	TU		Expansion	Calibrate	Level	Priority
Mobile Ped Box-File	15 x 20 x 22	\$662.00	\$1,067.00	\$784.00	\$816.00	\$716.00	\$1,152.00	\$650.00	\$955.00	\$1,601.00	\$599.00	\$948.00
Credenza Low BF and Open BC	60 x 20 x 22	\$1,204.00	\$2,172.00	\$2,135.00	\$1,713.00	\$1,166.00	\$2,050.00	\$1,228.00	\$1,248.00	\$2,461.00	\$907.00	\$2,463.00
Lateral File	36 x 24 x 29	\$1,045.00	\$1,474.00	\$1,097.00	\$1,130.00	\$1,167.00	\$1,695.00	\$928.00	\$1,365.00	\$2,467.00	\$812.00	\$1,104.00
Wardrobe Hat Shelf and Rod	15 x 24 x 72	\$1,136.00	\$1,400.00	\$1,309.00	\$1,545.00	\$790.00	\$2,303.00	\$1,047.00	\$1,079.00	\$2,054.00	\$1,017.00	\$1,476.00
Bookcase	36 x 12 x 72	\$1,072.00	\$876.00	\$970.00	\$1,374.00	\$1,125.00	\$2,069.00	\$855.00	\$978.00	\$1,669.00	\$985.00	\$1,117.00
Storage 2 Drawer Lateral and Storage	36 x 24 x 72	\$1,801.00	\$2,412.00	\$2,091.00	\$2,621.00	\$1,747.00	\$5,027.00	\$1,540.00	\$1,758.00	\$3,630.00	\$1,365.00	\$2,524.00

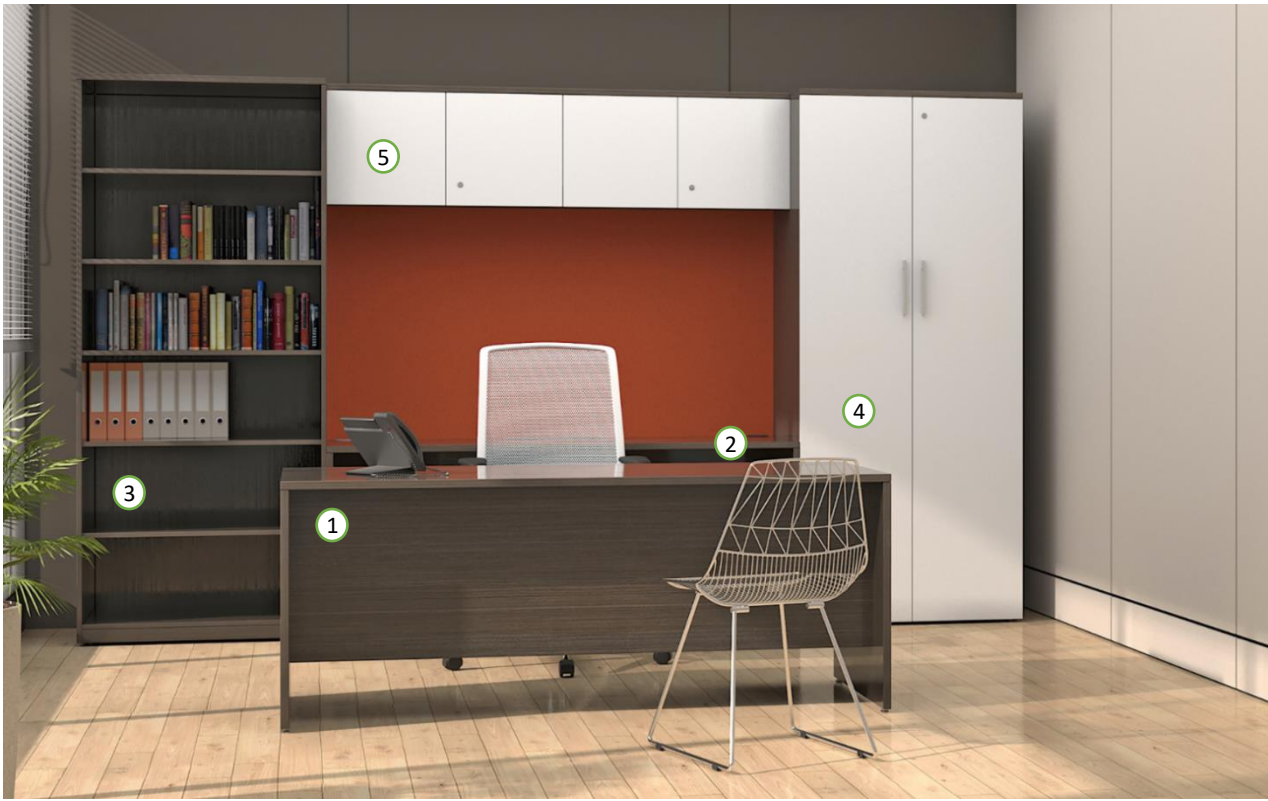

Typical 1

- ① Table Desk, Recessed Modesty, Box/File Left : \$1021.00
 - ② Table with Full Gables: \$561.00
 - ③ Bookcase: \$1307.00
 - ④ Wardrobe: \$1594.00
 - ⑤ Wall Mount Hutch, Closed: \$820.00
- TOTAL: \$5303.00 – 69% = \$1643.93

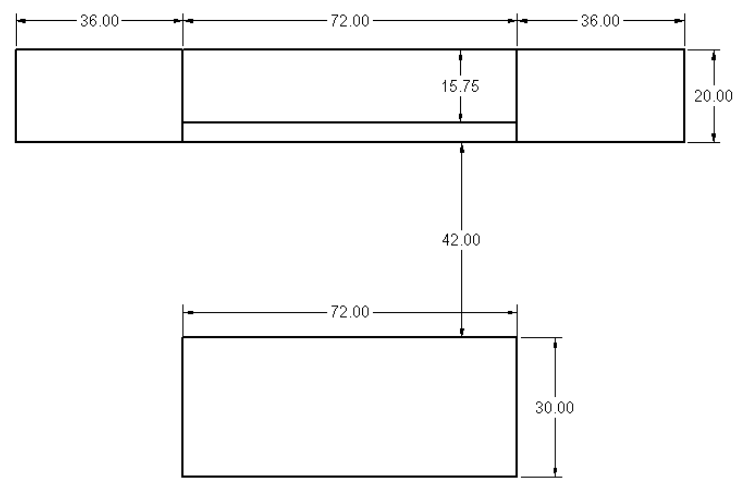

Private Office



Private and Open Office Configurations



Reception, Private and Open Office Configurations



Integrated Height Adjustable/Credenza with BRC Panels

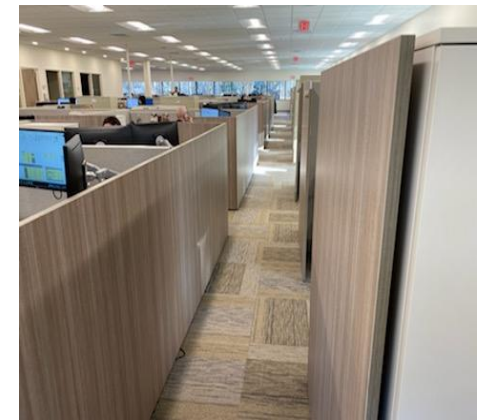

Gallery Panels
Glass panels are recessed into the top with no external channel for a clean look

Boardroom, Meeting, Casual and Technology Tables



Storage, Locker and Planter Solutions



FIL Product Line Features

1. 500 pages of standard products, from casegoods to desking
2. Standard LPL construction for cost effectiveness – HPL tops and fronts optional
3. BRC provides dealers with a blended solution by offering Herman Miller laminate, fabrics, lock cores and keys.
4. Custom abilities – We will source unique finishes or products that allow our clients to customize their furniture, offering one-of-a-kind solutions.
5. Customer service and quoting team – BRC is here to help, from drawing, quoting or tracking orders, we do everything we can to ensure our clients are happy.
6. BRC has 5 standard kick styles

7. BRC uses actual sizing
8. BRC has 6 standard handle options
These are different than HM handles, COM option available if required

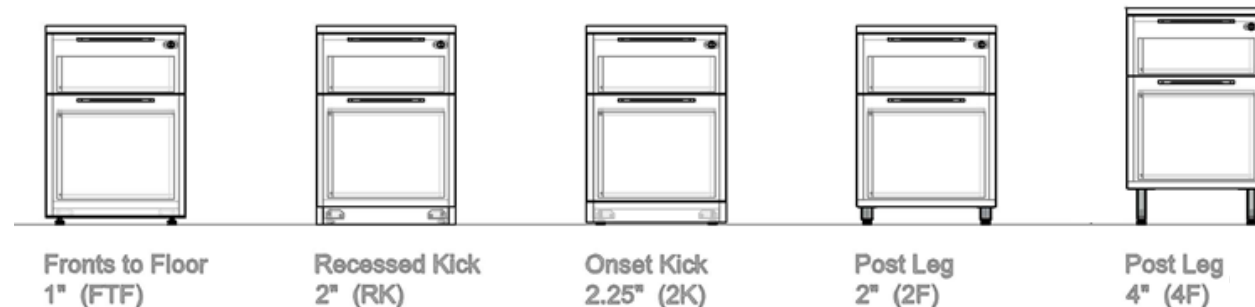
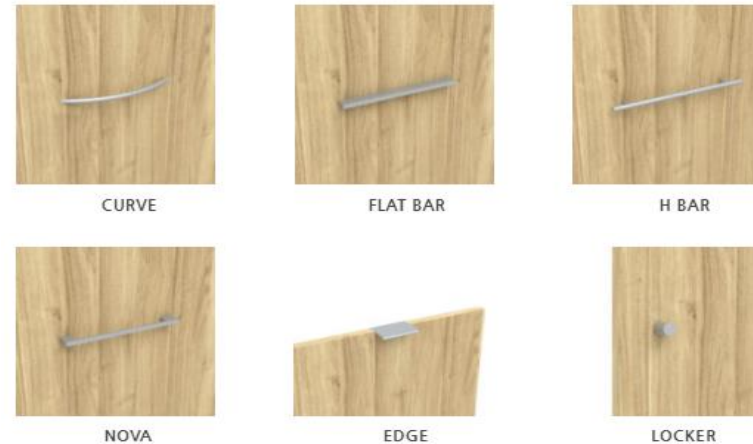

Opportunity to Blend – Send us your layouts so we can show where BRC would add the most value



Collaborations



Bloomingtondales



Blue Foundry Bank

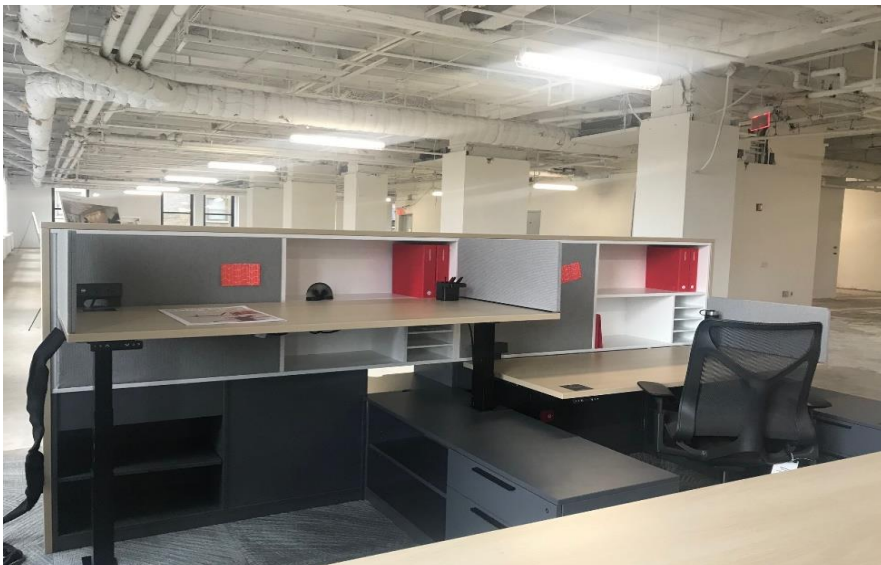

Macy's

HM Laminate Finishes by BRC

Laminate Color	Code
Aged Cherry	HX
Clear on Ash	LBA
Folkstone Grey	8Q
Light Anigre	HP
Soft White	LU
Light Brown Walnut	76
Medium Matte Walnut	LBU
Natural Maple	HM
Neutral Twill	LBF
Studio White	98
Oak on Ash	LBB
Phantom Cocoa	LBS
Phantom Ecu	LBR
Sarum Twill	LBG
Walnut on Ash	LBC
Warm Grey Neutral	WN
Warm Grey Teak	LBV
White	91
White Twill	LBQ



Aged Cherry HX



Clear on Ash LBA



Folkstone Grey 8Q



Light Anigre HP



Soft White LU

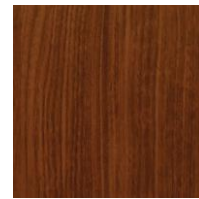

Light Brown Walnut 76



Medium Matte Walnut LBU

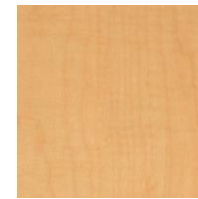

Natural Maple HM



Neutral Twill LBF



Studio White 98



Oak on Ash LBB



Phantom Cocoa LBS



Phantom Ecu LBR



Sarum Twill LBG



Walnut on Ash LBC



Warm Grey Neutral WN



Warm Grey Teak LBV



White 91



White Twill LBQ

HPL & LPL available for all finishes - Includes matching edge trim - Order using Herman Miller finish codes

HM Fabrics Finishes by BRC

Fabric Name	Family Code
Crossing	8T
Dex	3DE
Gem	95
Monologue	1MN
Tailored	235
Whisper	1WS
Crepe	92
Epic	3EP
Fish Net	22Q
Loom	1LM
Medley	1HA
Rivet	1RV
Twist	8R
Aristo	3AR
Bento	70
String Plaid	22V
Quilty	6S
Hopsak	14A



Order using Herman Miller finish codes

Submitting Quote Requests

Quote Request

Dealers submits inquiry to: Quotes@brc.group

Please Include:

- Project Name
- Estimated Project Install Date
- Timeline: Deliverables by BRC are required
- Outline deliverables required, such as:
 - A. Quick Price via email
 - B. Formal Quote
 - C. Formal Quote and Drawing
- Concept drawings is available
- Quantities
- Sizes (W x D x H)
- Descriptions
- Finishes (optional)
- Kick Style

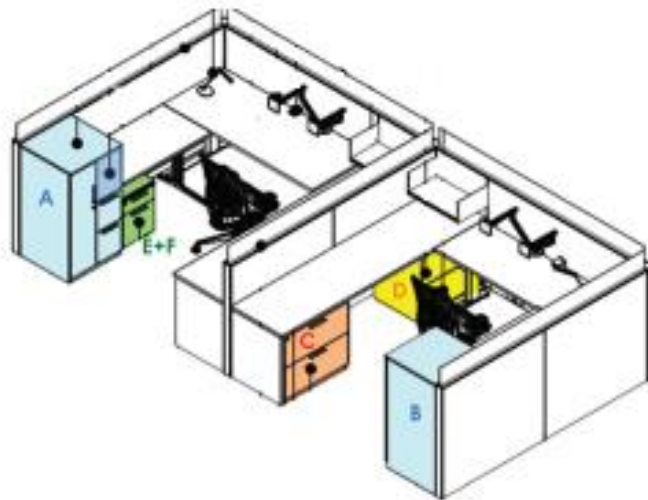

- A. (100) 24"D x 24"W x 45.5"H Storage Tower, Wardrobe Left
 - A. Wardrobe left with coat hook
 - B. File/File right with side-facing open bookcase above
 - C. Face above file/file to be writeable marker board
 - D. 98 Studio White laminate with Silver bar pulls
 - E. Recessed kick/standard base
 - F. *Include counterweights*
- B. (100) 24"D x 24"W x 45.5"H Storage Tower, Wardrobe Right
 - A. Wardrobe right with coat hook
 - B. File/File left with side-facing open bookcase above
 - C. Face above file/file to be writeable marker board
 - D. 98 Studio White laminate with Silver bar pulls
 - E. Recessed kick/standard base
 - F. *Include counterweights*
- C. (200) 24"D x 30"W x 27.25"H two-drawer lateral file
 - A. 98 Studio White laminate with Silver bar pulls
 - B. Recessed kick/standard base
 - C. *Include counterweights*
- D. (200) 24"D x 30"W x 27.25"H two high open bookcase
 - A. 98 Studio White laminate
 - B. Recessed kick/standard base
- E. (200) Mobile box/file pedestal
 - A. 98 Studio White laminate with Silver bar pulls
 - B. *Include pull handle*
 - C. *Include counterweights*
- F. (200) Mobile Ped Cushion top
 - A. 1"H
 - B. *Fabric – (Crossings)*

Do's and Dont's

Please note BRC does offer the following:

- 19 standard HM Laminates
- 18 standard HM Fabrics
- 4 Standard HM Paint colors. MS Silver, 91 White, 98 White and Graphite
- HM Hudson Locks
- Integrated height adjustable credenzas that can incorporate HM tables
- We can construct units to accept HM brackets to attach to the canvas unit. This is a special. A sample bracket is required so we can do a test fit.

Please note BRC **DOES NOT** offer the following:

- Metal storage cabinets
- Millwork
- Corian or stone
- Full HPL solution
- Powered panels
- Canvas C-Leg
- Exact match to the HM bar pull

Our Customers

jetBlue



TOMMY HILFIGER

AVISON
YOUNG

A V O N



Mercedes-Benz

FLIGHT
CENTRE™

The Washington Post



HBO



CohnReznick 
ADVISORY • ASSURANCE • TAX

VARSITY  BRANDS

 BlueCross
BlueShield



Welcome to:

ebrc

Start Here

A Herman Miller Design Readiness
Learning On-Demand Course



Your Local Southern Cali BRC Rep:
Sheila Shenasi, IIDA



C: (310) 920-0704

Sheila@INFINITYcontract.net

