



# Creative Corridors

WINSTON-SALEM, NORTH CAROLINA



Green



Artful



Iconic



Network

## VISIONARY MASTER PLAN AND DESIGN GUIDELINES SEPTEMBER 2011



NATIONAL  
ENDOWMENT  
FOR THE ARTS

This project made possible through a grant from the National Endowment for the Arts

**DESIGNWORKSHOP**

# ACKNOWLEDGEMENTS

The Winston-Salem Creative Corridors Visionary Master Plan and Design Guidelines would not have been possible without the support of the National Endowment for the Arts and the contributions of numerous organizations and people.

Creative Corridors Coalition  
Executive Committee

## Officers

Randall Tuttle, Chair  
James Taylor, Jr., Vice-Chair  
Doug Lewis, Secretary  
Thorns Craven, Treasurer

## Leadership

Owen Cooks,  
Administrative Committee Chair

Lee French,  
Communications Committee Chair

Russ Dubois & Joycelyn Johnson,  
Community Engagement Co-Chairs

Rence Callahan & Rosa Otero,  
Design Committee Co-Chairs

Jim Shaw & Milton Rhodes,  
Fundraising Committee Co-Chairs

## Staff

Bill Davis, Design Project Manager  
Jennifer Kiger, Coordinator

## Design Steering Committee

Rence Callahan, Chair	Marty Marion
Rosa Otero, Co-Chair	Wendy Miller
David Brown	Paul Norby
Thorns Craven	Jimmy Norwood
Amy Crum	Jennifer O'Kelly
Bill Davis	Katie Pepper
Russ Dubois	Milton Rhodes
Greg Errett	Anne Kesler Shields
David Finn	Karl Sjolund
Phillip Harrison	Amy Smitherman
Joycelyn Johnson	David Smitherman
Jennifer Kiger	Gwynne Taylor
Brian Kubecki	Jason Thiel
Henry Lafferty	Christy Turner
Doug Lewis	Randall Tuttle
Duncan Lewis	

## Directors

Gayle Anderson	Henry Lafferty
Carol Croop	Marty Marion
Carol Davis	Dean Naujoks
Jim DeCristo	Betty Quick
Nancy Dunn	Rev. Prince Rivers
Mark Dunnagan	Sandy Romanac
Natasha Gore	Carol Strohecker
Tom Ingram	Michael Suggs
Brian Kubecki	

## Ex-Officio Directors

Linda Garrou	Paul Norby
Christine Gorelick	Allen Joines
Pat Ivey	Ralph Womble

## Major Funders

National Endowment for the Arts  
City of Winston-Salem  
Winston-Salem Foundation  
BB&T Foundation  
DataMax Foundation  
James G. Hanes Memorial Fund  
John Wesley and Anna Hodgin Hanes Foundation  
Millennium Fund  
Reynolds American Foundation  
Richard J. Reynolds, III and Marie M. Reynolds  
Foundation  
Arts Council of Winston-Salem & Forsyth County  
Downtown Winston-Salem Partnership  
North Carolina Arts Council  
Doug Lewis  
Southeast Gateway Council

## Donors

Bill Davis  
Paul Fulton  
John McKinnon  
R. H. Stevenson  
Rence and Barbara Callahan  
Lee French  
Carroll Leggett  
Sam Ogburn  
Claire and Randall Tuttle

## In-Kind Donors

Bill Davis  
Marriott Hotel  
Henderson Bromstead Art  
Womble Carlyle Sandridge & Rice  
Bear Strategies  
WSJS  
Carol Croop  
Walter Robbs Callahan & Pierce  
Milton Rhodes Center for the Arts  
Trade Street Capital Partners

Neighborhood Solutions  
Winston-Salem Dash  
Center for Design Innovation  
Keiger Printing  
Old Salem Museum & Gardens  
Winston-Salem State University  
a/perture  
Pepsi  
Kernel Kustard  
Hawthorne Inn  
Brenda Veinrich Designs

## Collaborators

City of Winston-Salem  
Arts Council of Winston-Salem & Forsyth County  
Downtown Winston-Salem Partnership  
Winston-Salem Chamber of Commerce  
North Carolina Department of Transportation  
City-County Planning Board

## Design Team

### Design Workshop

Glenn Walters, Principal  
Richard Shaw, Principal  
Drake Fowler, Project Manager  
Natalie Grillo, Project Assistant  
Jom Naknakorn, Project Landscape Architect  
Nino Pero, Graphic Designer

### LK Studio

Larry Kirkland, Art Consultant

**Perry Howard**, Community Engagement

### Mulkey Engineers

Valoree K. Eikinas, Advising Engineer

### Donald McDonald Architects

Donald McDonald, Bridge Architect

## DESIGNWORKSHOP

Legal Building, 60 Biltmore Avenue  
Asheville, North Carolina 28801  
828-225-6901

# TABLE OF CONTENTS

1	<p><b>INTRODUCTION.....1</b></p> <ul style="list-style-type: none"> <li>Impact of Highway Construction.....2</li> <li>Background.....4</li> <li>Vision.....5</li> <li>Guiding Principles.....6</li> <li>Supporting Principles.....8                             <ul style="list-style-type: none"> <li>Artful Expression.....8</li> <li>Community.....8</li> <li>Environment.....9</li> <li>Economics.....9</li> </ul> </li> <li>Project Boundaries.....10</li> <li>Process.....12                             <ul style="list-style-type: none"> <li>NEA Grant Summary.....12</li> <li>NCDOT Art Policy.....12</li> <li>Themes.....12</li> </ul> </li> <li>Process Components.....13                             <ul style="list-style-type: none"> <li>Public Process Summary.....13</li> <li>Public Process.....14</li> </ul> </li> </ul>	
2	<p><b>DIAGNOSTICS.....17</b></p> <ul style="list-style-type: none"> <li>Context - Regional Scale.....18                             <ul style="list-style-type: none"> <li>Regional Context.....19</li> </ul> </li> <li>Context - City Scale.....20                             <ul style="list-style-type: none"> <li>City-Scale Context.....21</li> </ul> </li> <li>Site Photography Key Map.....22</li> <li>Site Photography.....23</li> <li>Concept Diagrams - Foundational Relationships.....26</li> <li>Concept Diagrams – Art Organization.....27</li> <li>Diagnostics.....28</li> <li>Concept Diagrams - Emphasis Zones.....29</li> </ul>	
3	<p><b>VISIONARY MASTER PLAN.....31</b></p> <ul style="list-style-type: none"> <li>Bridge Types &amp; Emphases.....32</li> <li>Inspirational Bridges.....37</li> <li>Inspirational Pedestrian Bridges.....39</li> <li>Lighting Strategies.....40</li> <li>Inspirational Lighting Strategies.....41</li> <li>Pedestrian Crossings.....42</li> <li>Integration of Art.....44</li> <li>Inspirational Art Integration.....46</li> <li>Special Places.....48</li> <li>Landscape Zones.....52</li> <li>Business 40 Illustrative Plan.....54</li> <li>US 52 and Salem Creek Connector Illustrative Plan.....56</li> <li>Martin Luther King JR. Drive - East Winston Illustrative Plan.....58</li> <li>Martin Luther King JR. Drive Extension and Broad Street Illustrative Plan.....60</li> <li>Peter's Creek Parkway and Broad Street Illustrative Plan.....62</li> </ul>	
4	<p><b>DESIGN GUIDELINES.....65</b></p> <ul style="list-style-type: none"> <li>General Guidelines.....66                             <ul style="list-style-type: none"> <li>Additional Design Standards.....67</li> </ul> </li> <li>Bridges.....68                             <ul style="list-style-type: none"> <li>Overall Design Intent.....68</li> <li>Design Considerations (typical to all bridges).....68</li> </ul> </li> </ul>	
		<ul style="list-style-type: none"> <li>Material Use Considerations.....68</li> <li>Beam.....68</li> <li>Abutment Walls.....68</li> <li>Center Pier Wall.....68</li> <li>Deck/Street/Pedestrian-Level Complex.....69</li> <li>End and Center Pilasters.....70</li> <li>Railing System.....70</li> <li>Bridge Lighting.....70</li> <li>Enhanced Bridges.....71</li> <li>Focal Bridges.....72</li> <li>Signature Bridges.....73</li> <li>Pedestrian Bridges.....74</li> <li>Temporary Bridge Treatments (Fourth Street).....74</li> <li>Pedestrian Crossings.....75                             <ul style="list-style-type: none"> <li>Major and Minor Thresholds and Neighborhood Crossing.....75</li> <li>Crosswalk Paving.....75</li> <li>Sidewalk Zone (Arterial Roadways).....75</li> </ul> </li> <li>Corridor Walls and Barriers.....76                             <ul style="list-style-type: none"> <li>Retaining Walls.....76</li> <li>Retaining Walls (Continued).....77</li> <li>Center Median.....78</li> <li>Sound Walls.....78</li> <li>Fences.....78</li> </ul> </li> <li>Artful Medians.....79</li> <li>Artful Green Highways Resources.....80                             <ul style="list-style-type: none"> <li>NCDOT Art Policy.....80</li> <li>The Green Highways Partnership.....80</li> <li>Guidelines for Bridge Design.....80</li> <li>The Green Roads Manual.....80</li> </ul> </li> <li>Landscape.....81                             <ul style="list-style-type: none"> <li>Landscape Zones.....81</li> <li>Gateway Treatment.....82</li> <li>Threshold Treatment.....83</li> <li>Parkway Treatment.....84</li> <li>Lowland Treatment.....85</li> <li>Traditional Streetscape.....86</li> <li>Trees.....88</li> <li>Shrubs.....88</li> <li>Plant Themes.....89</li> </ul> </li> <li>Fixtures.....90                             <ul style="list-style-type: none"> <li>Corridor “Street” Lighting.....90</li> <li>Corridor Signage.....90</li> </ul> </li> <li>Artful Lighting Designs.....91</li> <li>Artful Walls and Fence Designs.....92</li> </ul>
		<p style="font-size: 48pt; color: #76923c; font-weight: bold;">5</p> <p><b>PROCESS AND POLICY.....95</b></p> <ul style="list-style-type: none"> <li>Processes and Policies.....96                             <ul style="list-style-type: none"> <li>Master Plan and Administration Maintenance.....96</li> <li>Responsibilities.....96</li> <li>Funding for Artful Design.....96</li> <li>Artful Designer Selection.....97</li> <li>Design Review Process.....97</li> </ul> </li> </ul>





 Green



 Artful



 Iconic



 Network



# 1

## INTRODUCTION

This document captures the process and outcomes of the master-planning effort for Winston-Salem Creative Corridors by the design team, led by Design Workshop, from January through August, 2011. The objective of this phase was to develop a Visionary Master Plan guided by principles of aesthetics, urban design, placemaking and sustainability.

This document provides a visual and textual story of the design analysis, definition and discoveries that led to planning solutions and conclusions. It is intended for client use in presenting the project's vision to municipal and state officials for approvals, to attract the interest of the community and stakeholders, and to serve as the foundation for the next phases of the design process from which the plan will evolve.

This Visionary Master Plan and Design Guidelines illustrates a detailed vision for improving the visual appearance of the built environment by the inclusion of public art as well as landscape, architectural and engineering solutions that seek a high level of aesthetic integrity. When fully realized, this vision – based on central themes of **green, artful, iconic** and **network** – will enable the Corridors to further Winston-Salem's unique identity as the City of Arts and Innovation.

The first two chapters of this document establish the analytical foundation for the project and put it into proper context within the City's historical, cultural, environmental and regional position. The third chapter presents the Master Plan and includes the planning frameworks that shall guide the project. The fourth chapter presents the Design Standards and Guidelines that shall govern the installations of constructed elements within the Corridors. Finally, the last chapter explains the process and policy structure established so that the project can proceed toward a successful conclusion.

# IMPACT OF HIGHWAY CONSTRUCTION

The Winston-Salem Creative Corridors project was inspired by a simple question: “Why can’t the design of the highways that traverse our City create an image that is memorable?” The desire to enhance the aesthetic experience of a city’s highways has a long history and is shared by many communities. Rarely, however, has it been executed at the scale proposed for Winston-Salem. Recently, NCDOT adopted an art policy that enables the introduction of art into highway corridors. There have also been advancements made related to native landscaping programs. Several cities have received enhancements to some of their bridges. But nowhere in the state has the aesthetic design of an infrastructure system been considered holistically.

Parkways, which predate our current highways, were designed to provide a beautiful—not merely utilitarian—setting through which to travel. In the 1860s, Frederick Law Olmsted developed the original concept for parkways to function as linear parks that happened to contain a well-traveled road.

In 1923 the Bronx River Parkway set the stage for the modern parkway. Over the next few decades several parkways were constructed, including the Mount Vernon Memorial Parkway in Washington, D.C., the Merritt Parkway in Connecticut, and the Natchez Trace Parkway in Alabama and Tennessee.

Parkways also created economic-development. Construction began on the Blue Ridge Parkway in 1935 and was completed in 1987. This roadway connected a region and brought economic opportunity to previously isolated areas. The Blue Ridge Parkway is a significant example of a roadway designed to be sensitively fit to the land.

The development of an interstate system began in 1956 during Dwight Eisenhower’s presidency, stemming from a desire to create an integrated system of highways that would enable defense of our cities. Throughout the years, the primary design criterion for development of the interstate system has generally been executed for the purposes of mobility, safety and efficiency.

However, construction of select interstate segments provide examples of the ability to also create an environmentally sensitive and aesthetic roadway. In the 1960s, Lady Bird Johnson initiated efforts to beautify state highways with the planting of native wildflowers. The bluebells that line portions of Texas’ highways illustrate a simple landscape idea that creates a lasting impression. The planning and design process of the Paris-Lexington Road in Kentucky and I-70 through Glenwood Canyon in Colorado have increased the awareness of working collaboratively to create a roadway that is sensitively fitted to the land. *Flexibility in Highway Design* was published in 1997 by the Federal Highway Administration (FHWA) and the American Association of State Highway and Transportation Officials (AASHTO) to identify methods of creating an environmentally sensitive roadway through the use of flexible design standards.

While our highways have certainly connected the nation together and served their purpose relative to bringing prosperity and mobility to distant places, they also have contributed to sprawl and cultural division. They have supported the automobile as our primary mobility mode, which arguably has had serious impacts on our health and environment. As part of constructing these roadways, selected alignments often separated cities along racial and economic lines, causing urban decay and disharmony – as occurred in Winston-Salem with the development of Business 40 and US 52. The thriving neighborhoods south and east of Downtown were effectively cut off from the energy and vitality of Downtown. These divisions have affected the growth and prosperity of some of the neighborhoods and have created a barrier between cultures.

Unfortunately, the beautification of highways and its impacts on culture, health and environments are not always significant considerations of our mobility system as a whole. The workings of the transportation system design are subject to federally mandated standards. But hopefully, through a strong community voice combined with a vision for how the Corridors should look within Winston-Salem, a more pleasant and memorable experience can be created for the users and the City can assume a sense of identity and brand enhancement from their implementation.



Courtesy of Forsyth County Public Library Photograph Collection

Although highway construction brought economic and mobility opportunities to Winston-Salem, it also severed connections between neighborhoods and Downtown.



# IMPACT OF HIGHWAY CONSTRUCTION



Courtesy of Forsyth County Public Library Photograph Collection



The aesthetics of the Corridor have not changed significantly since its initial construction. In fact, it is arguable that it is less attractive now.



## BACKGROUND

This project began in response to NCDOT's plan to create improvements on specific roadways in Winston-Salem including: Business 40, US 52, Martin Luther King Jr. Dr., Broad St. and Salem Creek Connector. The planned improvements represent a sizeable financial investment and potential for disruption. They also offer an extraordinary opportunity to create a new, aesthetically pleasing transportation network and exciting visual environment that will endure for generations and affect the way residents and visitors perceive their surroundings.

Recognizing the opportunity, a group of civic leaders determined that the citizens of Winston-Salem should have a powerful voice in the execution of these improvements to ensure that they benefit the whole City; address local concerns; and create a well-articulated, well-integrated and aesthetically pleasing presentation.

Major stakeholders (NCDOT, the City of Winston-Salem, the Arts Council of Winston-Salem and Forsyth County, and the Downtown Winston-Salem Partnership) explored ways both to facilitate a design process and to create design guidelines for current and future work to be done on the Corridors. The Creative Corridors Coalition (CCC) was the outcome of this collaborative process. As of August 2011, the CCC was comprised of 64 member organizations and 2,000 members. The CCC's efforts have been endorsed by the secretaries of NCDOT and the North Carolina State Department of Commerce and Cultural Resources.

This document provides a vision that is sensitive to local concerns and issues. The cultural diversity along the Corridor reflects the diverse social make-up of the City. The design of the Corridors will impact the community socially, aesthetically and economically long into the future.





## VISION

The Creative Corridors project presents an excellent opportunity for Winston-Salem to brand itself. When completed, these Corridors will become a **green, artful,** and iconic transportation **network** that creates a unique setting for Downtown; that facilitates wayfinding; and that promotes a variety of transportation options—pedestrian, bicycle, and mass transit.

These corridors will function almost as sculpture gardens: creating a calming, humanizing setting for the display of art and good design principles, while also carrying out their main transportation function.

The people who have built this City have exemplified a resourceful, entrepreneurial and innovative way of occupying the land, building and creating an economy, and managing resources. This project will exemplify this spirit and will propose a high level of integration among aesthetics, economics, environmental stewardship and community harmony.

While Winston-Salem's rich history should certainly be celebrated, the design should also express the City's future aspirations. When complete, this project will reflect the City's image of itself as "The City of Arts and Innovation." This intelligent, illuminating, powerful concept will create an indelible impression in all who see it in the implemented Creative Corridors project.

This project can be a catalyst for repairing disconnections within the community and for promoting cohesiveness and unity. Although the people and events unique to the City's history should be revealed neighborhood by neighborhood, the common thread that ties all of the Corridors together should also be highlighted so that the image of the City overall is celebrated and so each portion of the Corridor is treated with equal dignity and respect.

Finally, this project offers the opportunity for Winston-Salem to create an inclusive, community-building process and policy that can inspire similar projects, demonstrating the benefits of enabling citizens of a community to exercise a strong voice in shaping the quality of their built environment into the future.





# GUIDING PRINCIPLES

Upon project completion, these Corridors will be a unified system of elements that creates a unique identity for the City of Winston-Salem. Specific themes have been identified and are how this unique brand will be established. These defining themes – Green, Artful, Iconic, Network – inform the breadth and scope of the Corridors as a whole as well as the detail of each specific element in the Corridors, whether a bridge, street, tree or fixture.



## Green

Green is a standard as well as an attitude about how we design and construct things attractively and functionally out of live materials that work with nature, rather than against it. Designing green requires a broad understanding of natural systems and how they interact. Green design promotes nature and brings its cleansing qualities into the center of a city. A green approach considers the integration of new technology into all aspects of design.



Living Wall



Streetside Stormwater Management



Alley of Live Oaks



## Artful

Artful design lifts the spirit and elevates our perception and appreciation of the built environment. Ordinary urban elements become important when they are designed artfully. Like Iconic structures, they attach themselves to our perception of a place. Artful installations draw people to them, just to experience them.



Cloud Gate ("The Bean"), Chicago, Illinois



Artful Retaining Wall



Artful Bridge in Central Park, New York City



# GUIDING PRINCIPLES



## Iconic

Great cities of the world have memorable structures that create a lasting image. They create place recognition and become part of the City's identity. Even if you have never been there, you instantly know from looking at a picture, where the structure is located. They become powerful symbols that create a brand for a city.



Gateway Arch, St. Louis, Missouri



Golden Gate Bridge, San Francisco, California



Liberty Bridge, Greenville, South Carolina



## Network

Designing integrated networks has a compounding effect on a place's sustainability. Each piece alone adds value; and together, the interconnected network creates long-term value and unity. Integrated networks require a comprehensive approach to layering ideas and technologies in creative ways so that the whole city is elevated from the standpoint of mobility, economy, access, comfort and beauty.



Paris Boulevard



Rock Creek Park, Washington, D.C.



Network of Bridges, Prague, Czech Republic



# SUPPORTING PRINCIPLES

The process to develop this Visionary Master Plan and Design Guidelines included a deliberate and comprehensive approach to sustainable design solutions. Each of the principles identified below – supported by the consultant team’s DW Legacy Design® categories of Environment, Community, Aesthetics and Economics – helped to shape the final outcome and determine design solutions.

## Artful Expression

- Aesthetically superior design and craftsmanship executed by a capable design team that draws upon national and regional resources.
- Design principles integrated into each element of the Corridors so that the overall effect is well proportioned, balanced, in scale and in harmony with the environment.
- The historic and cultural heritage of Winston-Salem made apparent in the forms, materials, symbols, colors and other details of elements. The result will be a design that reflects the aspirations of the community.
- Innovation expressed in multi-functional and sustainable engineering and design.
- Goals for the Corridor include: environmental enhancement, timeless quality, durability of design and materials, and plant selection that evolves through and evokes the seasons.



## Community

- Physical and cultural connectivity between the existing neighborhoods and districts promoted by creating effective networks for pedestrians, bicycles, automobiles and other modes of transportation and by ensuring that priorities are equally distributed around the network and balance is achieved in the design from place to place.
- Cultural relevance promoted by engaging the neighborhoods that are part of the Corridors in the design process and by choosing artistic expressions that are meaningful to the people in those neighborhoods.
- Cooperation achieved by integrating the various planning efforts conducted around the City into the master plan and design for the Corridors.
- Civic pride enhanced by an inclusive design process and by executing a design for each of the Corridors that expresses the City’s overall aspirations.
- City endorsement achieved by creating formal policies that ensure guidelines respect the limitations of the City’s budgets and adherence to them is required when the projects are initiated.
- More efficient, direct vehicular movement along the north side of Downtown Winston and linkage of the each and west sides of Center City developed by gaining City support for the extension of MLK Jr. Drive to Broad St.





# SUPPORTING PRINCIPLES

## Environment

- Energy use managed through the selection of energy-efficient fixtures and the use of materials with a long life cycle.
- Innovative water management achieved by following currently accepted Best Management Practices (BMPs).
- Materials sourced regionally and either produced, extracted or manufactured according to LEED® (Leadership in Energy and Environmental Design) requirements.
- Multi-modal transportation elements included and the amount and quality of pedestrian and bicycle connectivity increased through and across the Corridors.
- Management of light pollution achieved by choosing lighting fixtures that direct light downward using cut-off devices and by carefully placing dramatic lighting effects where light spillage will not negatively impact residents.
- Air quality maintained or improved by increasing the volume of tree canopy within the Corridors.
- Urban heat island temperatures controlled by increasing the amount of tree canopy, reducing the amount of impervious surface and using more-reflective hardscape (high albedo) paving surfaces.
- Energy creation promoted by the inclusion of practical and artful solar or wind installations that can be used for direct power or to put energy back into the grid.



## Economics

- Property value increased on properties adjacent to the Corridors as a result of the design interventions described in this document.
- Public and private investment increased as a result of the execution of these projects.
- Tourism increased as a result of these Corridors becoming noteworthy and memorable.
- Brand enhancement enlarged due to the completeness of the expression within these Corridors as the “City of Arts and Innovation” and due to increased publicity and third-party validation.
- New industry attracted that increases the quality and quantity of jobs and the City’s brand enhancement.
- Costs and investments balanced so that the any additional cost for these aesthetic improvements is quantified, accepted and budgeted for through the City’s Capital Improvement Plan or other means.
- Maintenance costs managed by carefully considering the design, materials, construction methods and lifecycle of each of the elements proposed for the Corridors.





# PROJECT BOUNDARIES

The idea of creating a Visionary Master Plan began many years ago by the Downtown Partnership. The plan has identified six major roadways to be studied: Business 40, US 52, Martin Luther King Jr. Drive, Broad Street, Peter's Creek Parkway and the Salem Creek Connector. NCDOT plans to replace 11 bridges and rebuild the entire expressway along a 1.5-mile stretch of Business 40 as it passes through the southern side of downtown Winston-Salem.

**Business 40** is the main east-west arterial road through Winston-Salem. Traveling through the heart of Winston-Salem, it connects to Interstate 40 and divides Old Salem and Downtown Winston. All visitors coming from the east or west gain their first impression of the City while on Bus 40.

**US 52** is main north-south route through Winston-Salem. Dividing Downtown Winston from East Winston, it links to Interstate 40 and makes important connections to Business 40, Martin Luther King Jr. Drive and the future Salem Creek Connector. All visitors coming from the north and south use this roadway.

**Martin Luther King Jr. Drive** is the spine of East Winston and its historic neighborhoods, running directly through the Winston-Salem State University campus. With its extension (that begins northwest of the City at Broad Street), it moves southeast, connecting to both US 52 and Business 40.

**Broad Street** is an important corridor bordering the west side of Downtown Winston, connecting the northwest neighborhoods to the rest of the City. It intersects with Martin Luther King Jr. Drive to the north and Business 40 to the south.

**Peters Creek Parkway** is a major arterial road that connects to Interstate 40 southwest of the City through a retail corridor and to the BB&T Ballpark neighborhood on the western side of Downtown Winston. Future modifications to this road will change traffic patterns into the City.

**Salem Creek Connector**, once constructed, will connect US 52 to the City's future Piedmont Triad Research Park. It will be an important secondary route for people traveling into Downtown from the south.

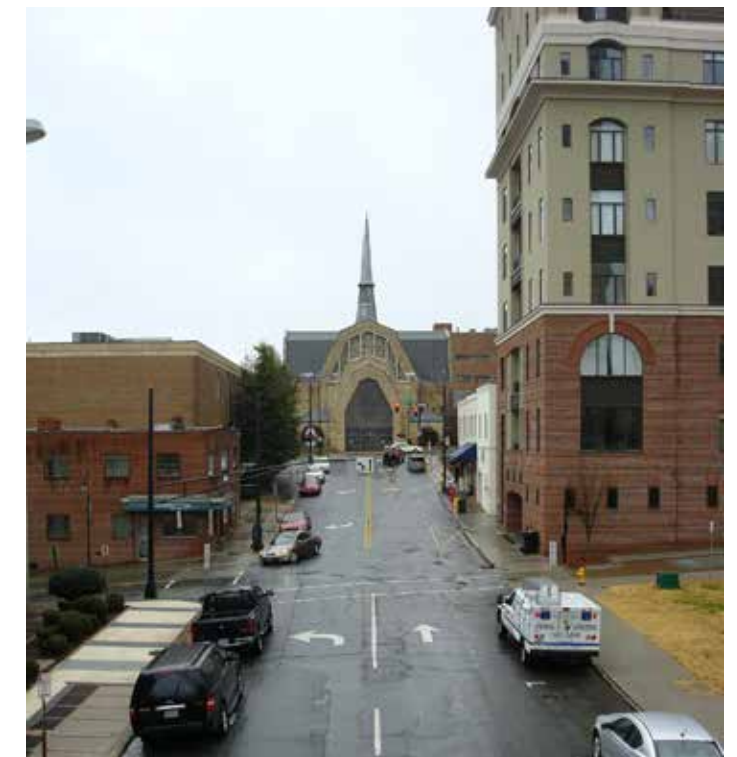
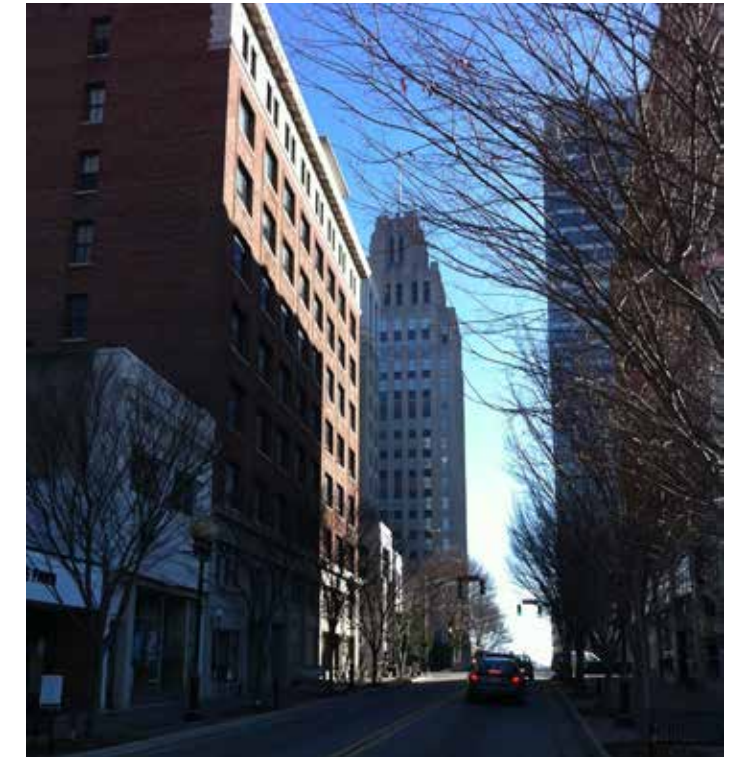



# PROJECT BOUNDARIES

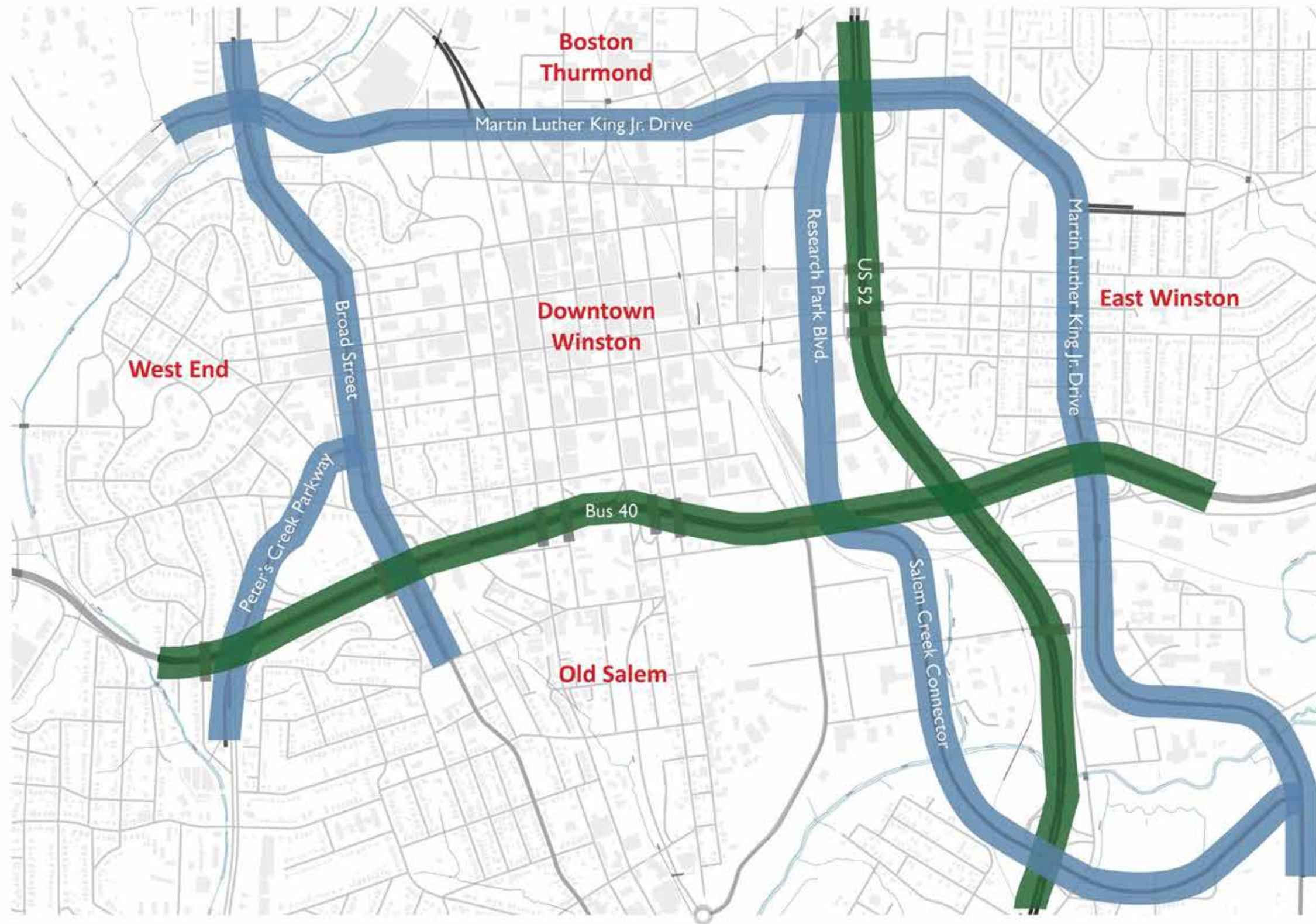

The project includes roadways of different scale, speed and use. The map to the left identifies the corridors that are included in this study.

**Expressways:** US 52 and Business 40 are the major expressways in and out of Winston-Salem

**Urban Arterials:** These major roads are commonly used to circulate throughout town.



# PROCESS

## NEA Grant Summary

A grant was obtained from the National Endowments for the Arts (NEA) “to support the Winston-Salem Creative Corridors Project. As part of that, a nationally renowned team of artists and urban designers was hired to create a master plan to incorporate art and a high level of design in the highway infrastructure project built through downtown Winston-Salem. The effort associated with the grant includes creating a community involvement process to enable the creation of this master plan and design guidelines. The intended outcome is for Arts to strengthen the communities and nourish the environments that surround these Corridors.”

The project was initiated by the Arts Council of Winston-Salem and Forsyth County, whose mission calls for “efficiently and effectively raising funds and making grants, working to strengthen our broad array of arts resources and offerings, and promoting the arts... creating an environment in which the arts flourish and enrich the quality of life in Forsyth and surrounding counties.”

## NCDOT Art Policy

NCDOT has enacted an art policy, the purpose of which is to “establish procedures for the department to evaluate and permit the placement of Public Art within its right of way.” In their view, “transportation facilities enhanced by public art elements provide aesthetic and cultural benefits to a community.” NCDOT’s first priority is to provide a safe and efficient transportation facility, but they also recognize that the way transportation corridors are designed and executed can have additional economic, environmental, aesthetic and community benefits for Winston-Salem. NCDOT’s public art policy sets forth a process for review and approval of art within its right-of-way as well as guidelines for funding and maintenance of improvements.

## Themes

**Moravian History, Culture, Craft and Philosophy** – The imprint and inspiration left by the people who settled this land in 1766 are hard to avoid when one walks down Old Salem’s streets. The Moravians were hard-working, articulate, artistic, devoted, creative, values-driven, progressive, peaceful and pragmatic people. Their philosophy of a prudent but artful design response to the planning and construction of building and landscapes is a philosophy shared by the people of the City today.

**Higher Education and Research** – Winston-Salem has a long history of celebrating and championing education and boasts some of the best and most diverse higher-education and research environments in the region. It is presently home to one college (Salem College), one community college (Forsyth Technical Community College) and three universities (Winston-Salem State University, Wake Forest University and the University of North Carolina School of the Arts). This commitment to higher learning creates the opportunity to attract the best and brightest people to the City.

**Performing Arts** – Since its residents constructed the Colonies’ first stringed instruments and organs and formed its first chamber ensembles and orchestras in the 1700s, Winston-Salem has been a key center for the performing arts. It is home to many local art attractions and festivals and boasts of having one of the most exclusive arts conservatories in the world: the University of North Carolina School of the Arts.

**Industrial Heritage and Reinvention (textiles, tobacco, research, etc.)** – Throughout its history, the City has responded to challenges and opportunities to continue to evolve economically. Much of what Winston-

Salem is today can be traced back to the tobacco and textile industries that first began in the mid-1800s. The beginning of the 20th century brought what are probably the best-known names in textiles and tobacco: the Hanes Corporation and the R.J. Reynolds Tobacco Company.

**Trees, Landscape and Greenness** – The Piedmont Region of North Carolina provides some of the highest biodiversity in the country. The City is committed to promoting and retaining its image as a Green City and as a Tree City.

**Industrious and Purposeful People** – Those who built this City responded to the challenges of the day with a work ethic and spirit that enabled them to overcome many obstacles. This spirit lives in the people today as they envision a future beyond their agricultural and industrial past.

**Literary Arts** – Winston-Salem has been committed to promoting the Arts as a way of life since its inception, evidenced by the formation of the nation’s very first Arts Council in 1949. Arts continue to shape the way that the City presents itself to the world.

**Cultural Diversity and Cultural History** – Winston-Salem has a long history of cultural diversity. City leaders are committed to evolving and creating a new chapter based on unity and equality and on a recognition that a great City is composed of its cultural influences.

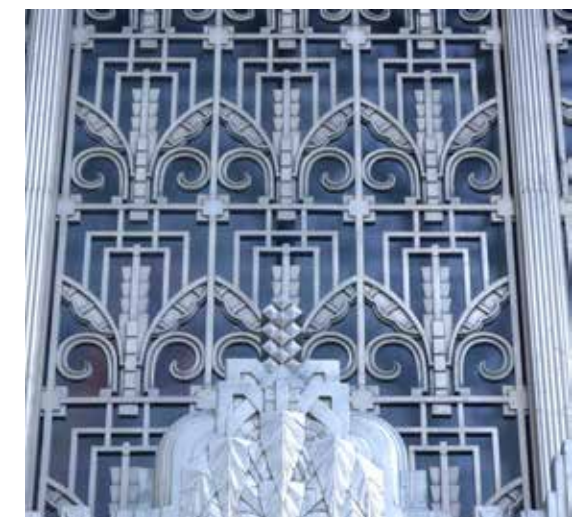



# PROCESS COMPONENTS

## Public Process Summary

The hallmark of the process to achieve this Visionary Master Plan and Design Guidelines is a commitment to engaging the public in the visioning and decision-making process. The CCC, along with its consultants, involved the public in various ways since the project kicked-off in January, 2011. This engagement included community presentations, workshops, open meetings, group meetings, focus groups and individual interviews. The CCC operated a website and Facebook page for the entire length of the process, allowing individuals who were not able to attend meetings to still participate electronically. Feedback was collected from those without internet access, through phone surveys as well as in person. Moving forward, community engagement will remain a key part of the process in attaining final designs.

In total, over 170 meetings were held with stakeholder groups and neighborhoods that are part of the Corridors between January and August 2011. Throughout the project duration, strategies were refined, including changes to meeting locations, outreach methods and meeting format to ensure a broad demographic was actively engaged in expressing ideas and sharing a sense of ownership. These meetings and workshops enabled the design team to create plans and guidelines that are inspired by the shared passion and commitment of a broad range of residents of Winston-Salem.

In addition, an online survey was conducted between June 14 and July 1, 2011 that included 480 respondents and supplemental information was collected in public meetings. From all of the data collected the following can be summarized:

- Many of the participants (42%) are long-time residents – over 20 years.
- The themes respondents thought were most appropriate were related to the City's history – including Moravian history, craft and philosophy and the City's industrial heritage. Strong response was also given to higher education and research as well as musical arts and dance.
- Nearly all respondents (96%) felt that Winston-Salem should work towards achieving the vision and themes articulated in the Visionary Master Plan.
- The aesthetic values most preferred relate to having lasting value, standing the test of time and being reflective of Winston-Salem. Additional support was given to the idea of expressing what the City aspires to be, while also being accepted by NCDOT and the City.
- The respondents generally liked the many design concepts presented throughout the process. However, some preferred for them to be more modern and others preferred them to be more traditional.
- There was great support for continued work toward finding ways to fund the project, even if it costs more than what NCDOT has budgeted.

Based on the feedback obtained in the above survey and in various meetings held during the process, it is believed that the Visionary Master Plan and Design Guidelines reflects the desires of the community that participated in the project. More work needs to be done, however, to ensure that more participation occurs as the project moves forward so that it continues to be representative of a broad spectrum of Winston-Salem's residents.

## Select Questions and Summaries of Responses from Public Meetings

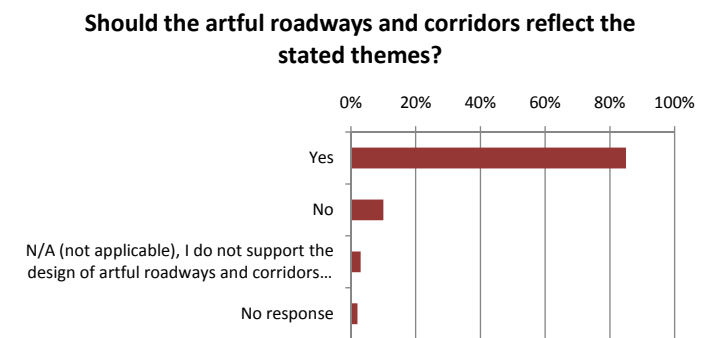
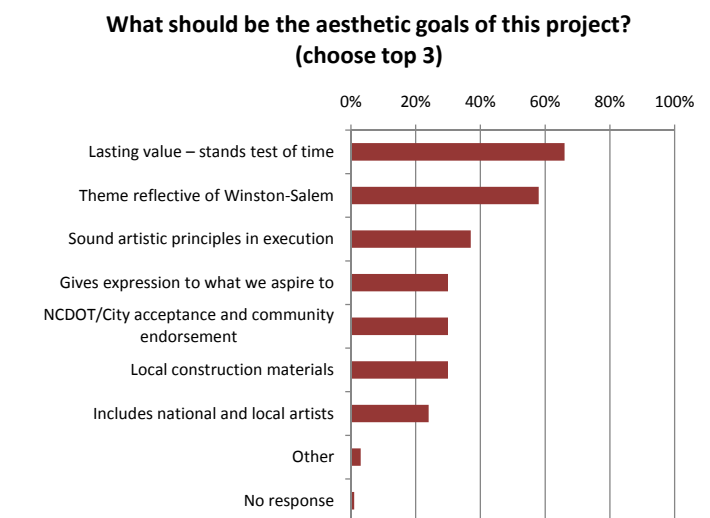
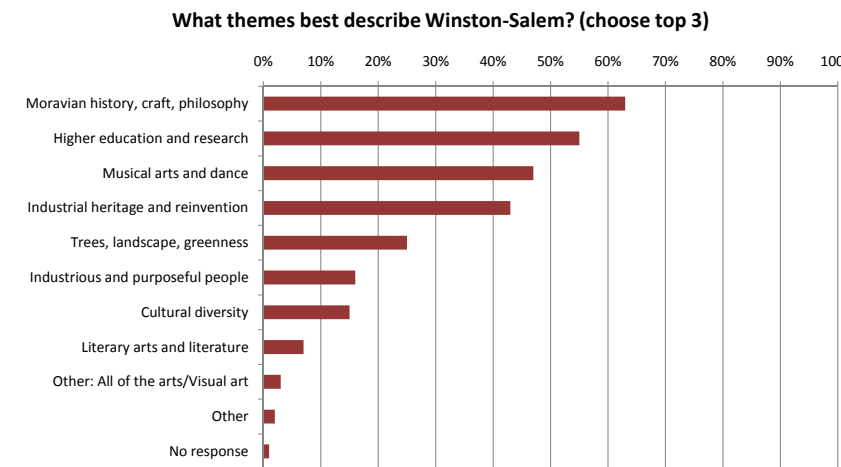



# PUBLIC PROCESS

From the project's inception in January, 2011, more than 170 total meetings were held with the public, assorted neighborhood groups, individual stakeholders, many community groups, government officials and various internal coalition committees – all in an effort to make the development of the Visionary Master Plan and Design Guidelines a fully inclusive and transparent process for the people of Winston-Salem. In addition a visual preference survey was conducted with individuals and community organizations from March through May. The graphic below documents the monumental undertaking this process was to accomplish in such a short amount of time. Each dot represents a different meeting that was held from February through October, 2011.

**February 7:** The Creative Corridors Coalition kicked-off the Design Process for the Visionary Master Plan and Design Guidelines of the Creative Corridors.

- PUBLIC INPUT MEETINGS
- COMMUNITY ENGAGEMENT MEETINGS
- ORGANIZATIONAL AND TEAM MEETINGS

**February 18:** The design team spent a week in Winston-Salem interviewing multiple stakeholder groups and gathering public input regarding design themes for the Corridors. One exercise asked residents to envision the completed Corridors and write a "letter home" describing that vision. Here are few examples of those letters:

*"I just moved to Winston-Salem. This City has the most interesting and creative gateways in the Downtown. They tell a story: it's inspiring; it is so inviting. Somehow the roads create a sense of place and purpose—framing the Downtown area. You have to come visit to see."*

*"I now know that my decision to move to Winston-Salem was the right one. As I drive through the City I feel a sense of belonging already because the Corridors are beautifully integrated into the surrounding community. There is an intentional plan to make it easy to navigate from one side of the City to another. The drive to work on 40 is calming, pleasant and full of public art. No more panicking as I merge onto the main thoroughfares – the City flows with aesthetically pleasing vistas."*

**February 23:** The design team presented some of the common themes (from prior public meetings) to the residents of Winston-Salem and then refined project goals based on public preferences to those themes.



**March 15:** The design team presented the project themes to the residents of the East Winston neighborhood. Through polling and comment gathering, the team received feedback on the overall project themes as well as impressions specific to Martin Luther King Jr. Drive.

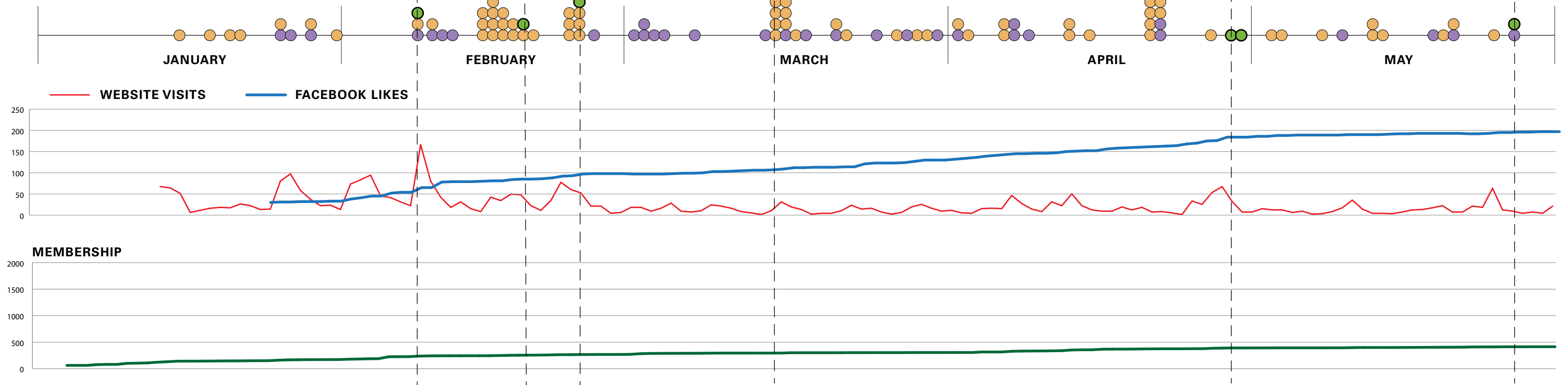



# PUBLIC PROCESS

**April 28:** At another public meeting, the design team presented its analysis of the Corridors as well as a draft of where emphasis should be placed. The team also presented a first look at potential bridge designs and conducted a public poll on the overall direction of the project.

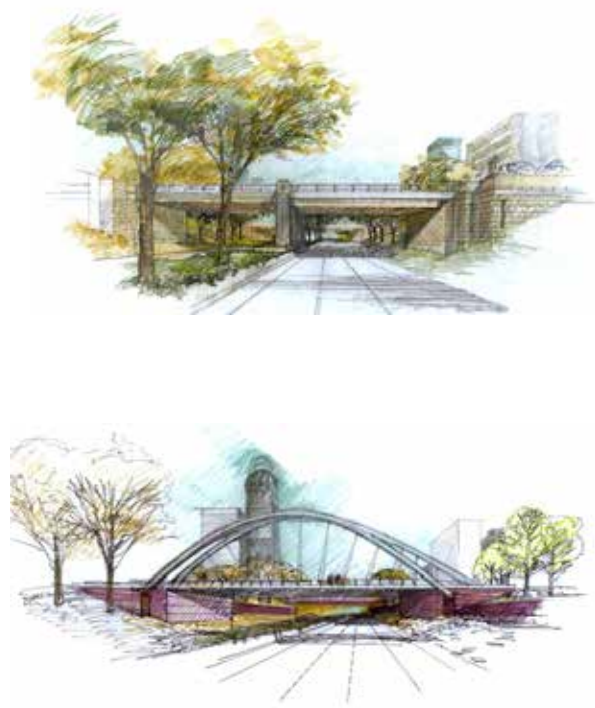
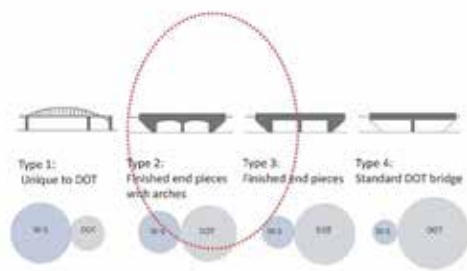
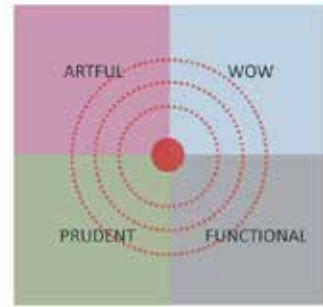

**May 26:** The design team met with local East Winston leaders and discussed the opportunities and challenges with the Martin Luther King Jr. Drive Corridor. The group discussed how the integration of art could elevate the design and overcome the spatial challenges in the Corridor.



**June 30:** In conjunction with an online poll, the design team presented the draft plan for the Corridors and gathered public feedback on areas where the plan could improve.

**September 1:** The Creative Corridors Steering Committee received the final draft of the Visionary Master Plan and Design Guidelines from the design team and reviewed each page in detail.

**October 20:** The Creative Corridors Coalition revealed the final Visionary Master Plan and Design Guidelines to the public at a celebratory dedication ceremony.

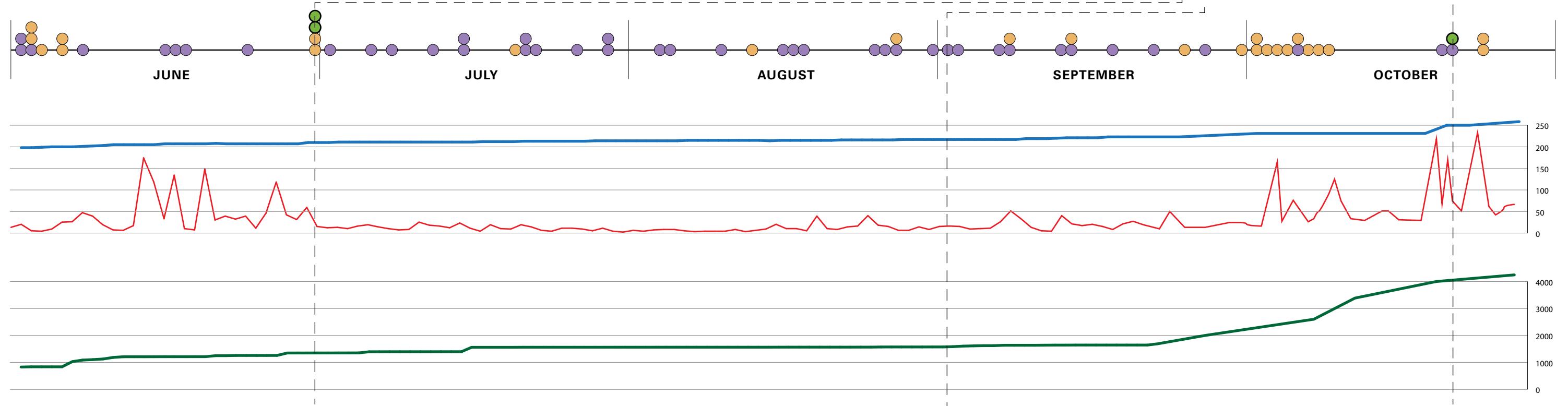





 Green



 Artful



 Iconic



 Network



# 2

## DIAGNOSTICS

The hallmark of a thorough planning and design process includes a deep exploration into the various systems that have an influence on the site. The design team accomplished this by gaining an understanding of the sites through a mapping overlay process that put the areas into regional- and city-scaled contexts. This mapping work, along with several layers of community engagement and stakeholder input, enabled the design team to create a series of diagrams that form the foundation for the Visionary Master Plan and Design Guidelines.



# CONTEXT - REGIONAL SCALE

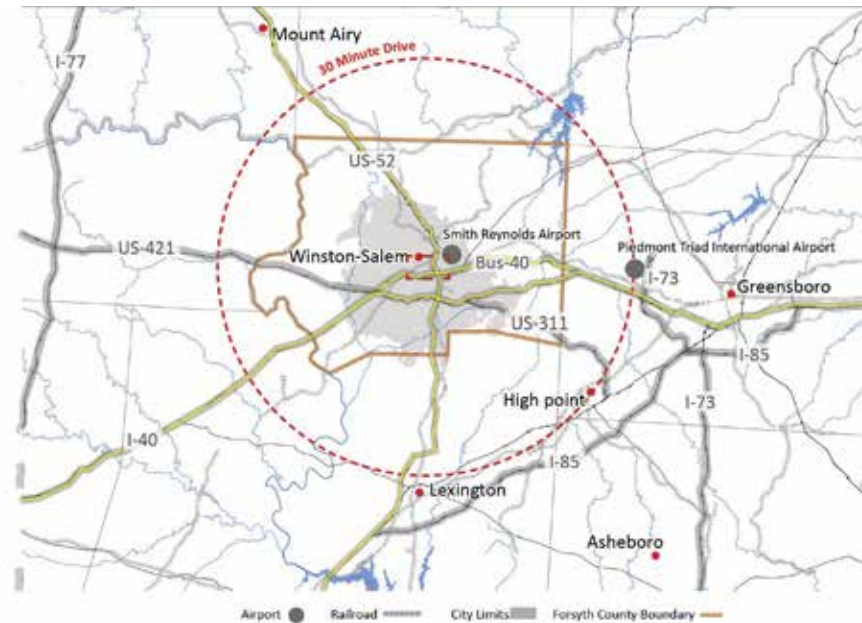

## Regional Transportation

I-40 and Business 40 connect the region together east to west - particularly Winston-Salem and Greensboro - carrying many commuters. US 52 connects the region north to south.

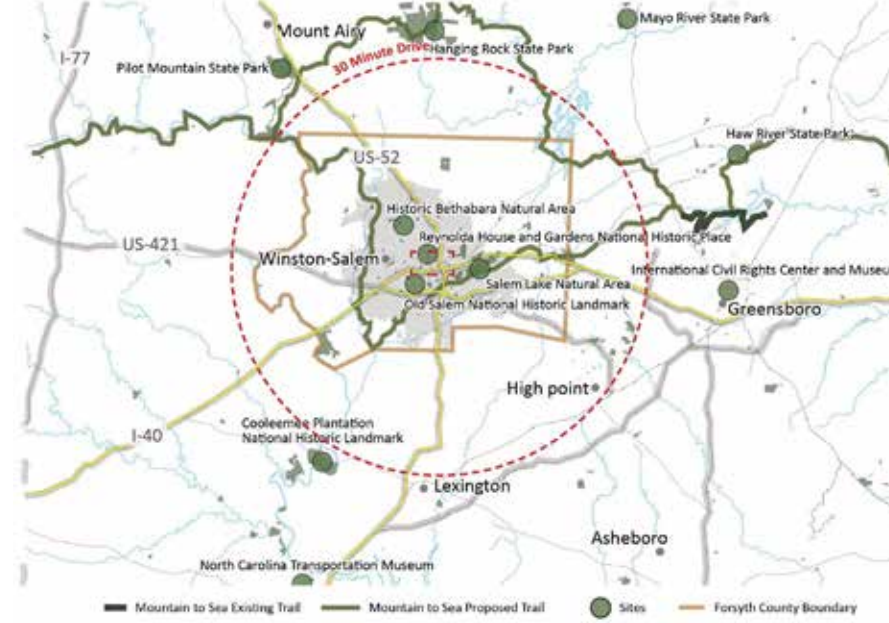

## Regional Open Space

The Mountain to Sea Trail passes through Winston-Salem.

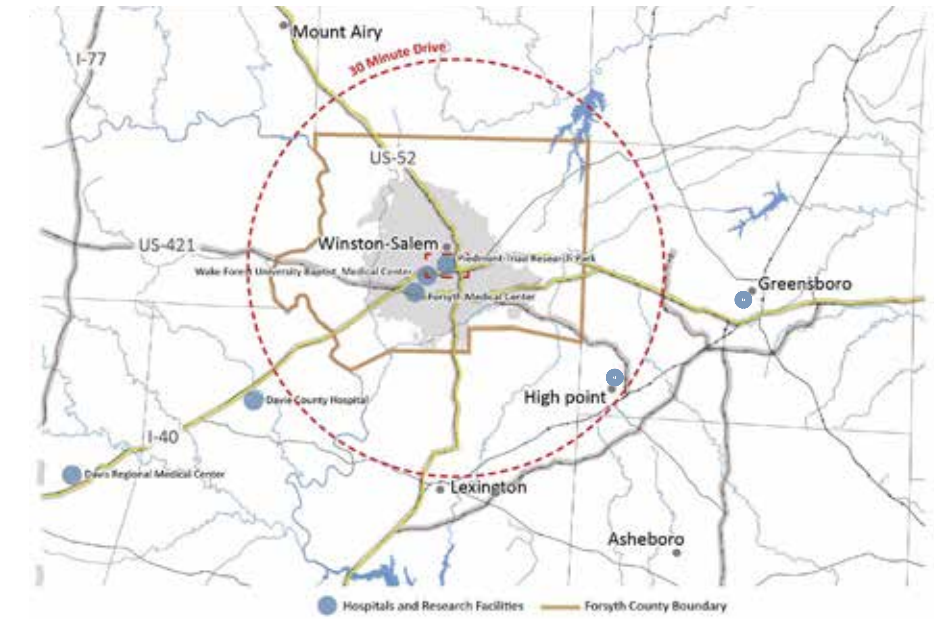

## Regional Medical Facilities

Capitalizing on the higher education located there, Winston-Salem hosts the region's medical facilities which provide many jobs to the region.

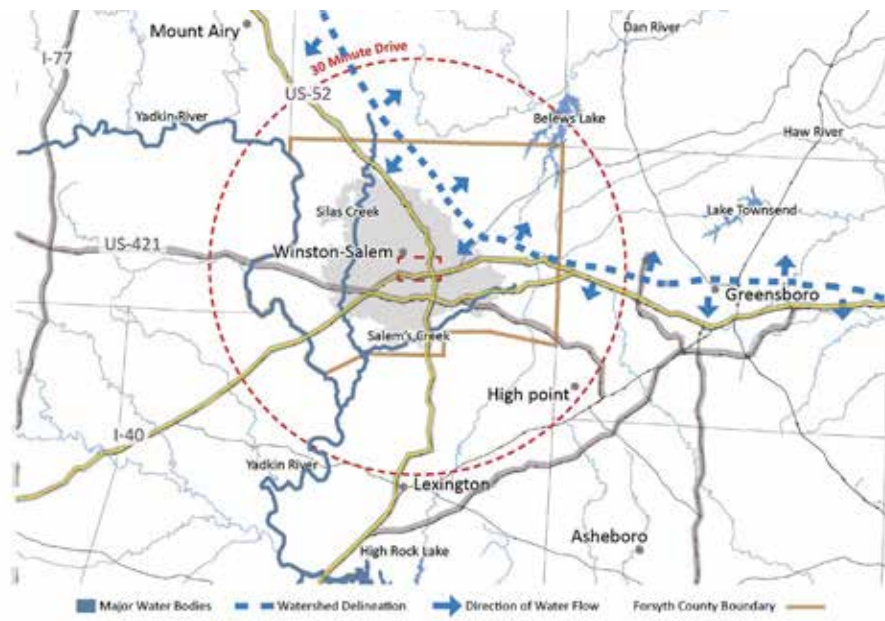

## Regional Watersheds

A major watershed defines drainage patterns northeast of Winston-Salem orienting much of the City's water toward the southeast to High Rock Lake.

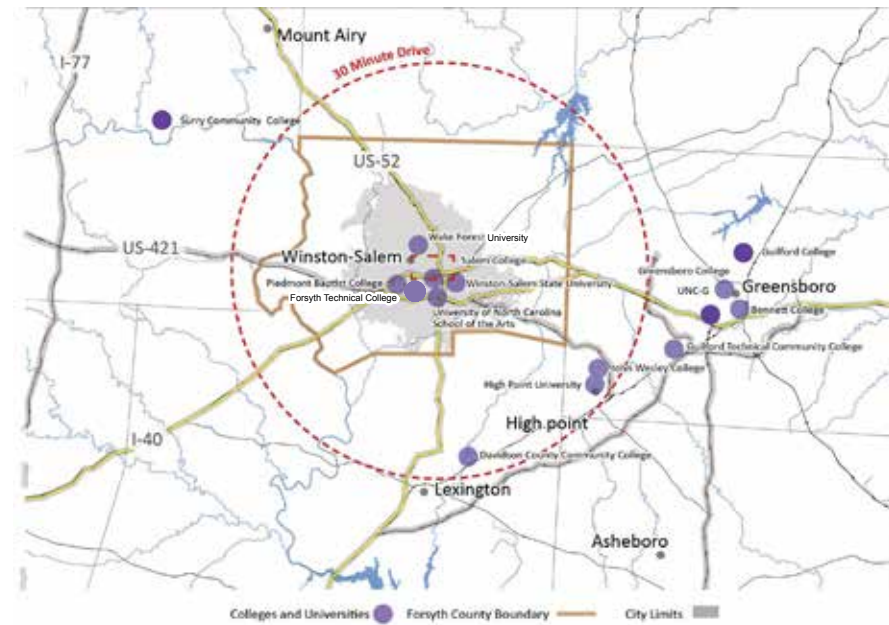

## Regional Higher Education

The region's economy is enhanced by its many higher-education facilities that create jobs and knowledge-based workers that help define the economy.

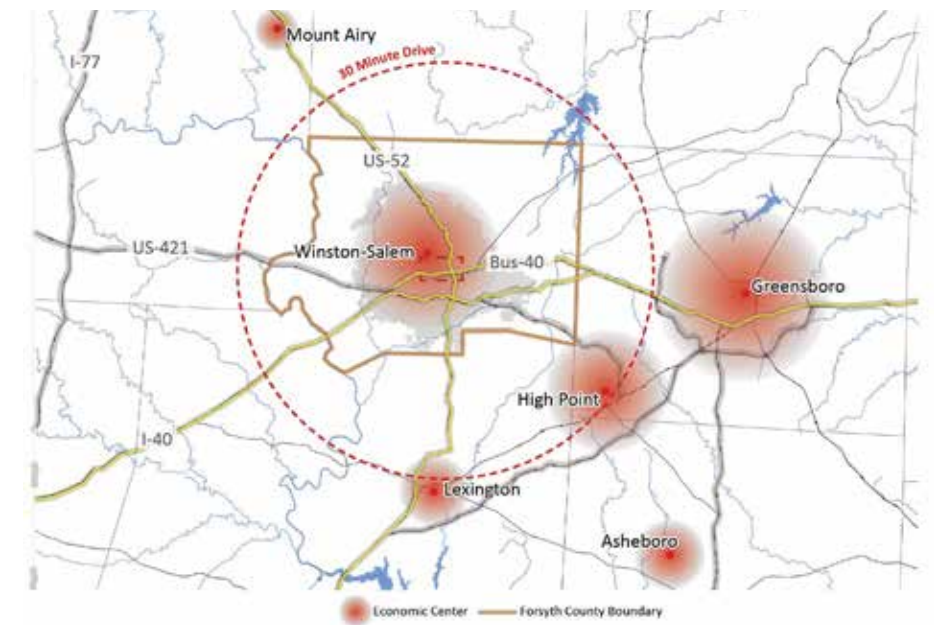

## Regional Economic Centers

Winston-Salem is in a region called the "Piedmont Triad" region which also includes High Point and Greensboro forming a regional economic base. Business 40 is an important part of the movement of goods and services between Winston-Salem and Greensboro.



# CONTEXT - REGIONAL SCALE

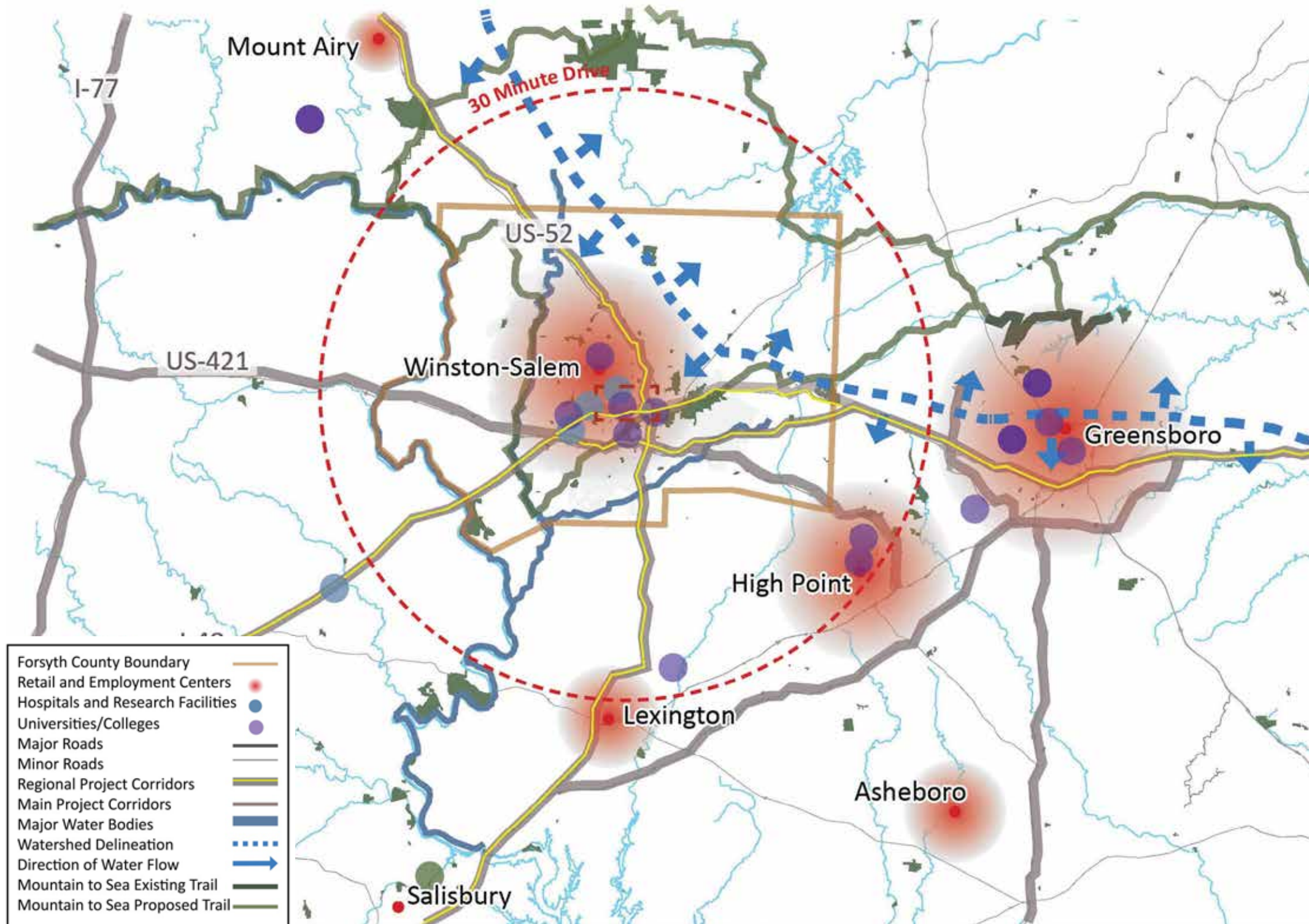

## Regional Context

The Corridors are an essential component of the Region's access, mobility and economic network that includes multi-modal transportation, greenways and open space, natural systems, education, culture and learning. Considering the overlap of these systems will enable the Corridors to be a catalytic component of the Region's economic resurgence, bringing regional significance to the design and planning recommendations proposed for the Corridors.



# CONTEXT - CITY SCALE

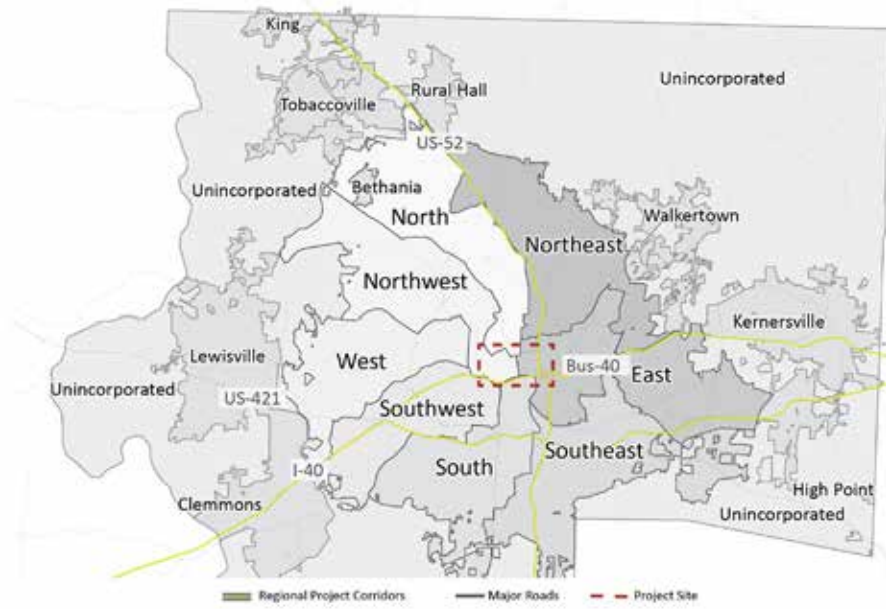

## Ward Boundaries

Winston-Salem is divided into wards. The Corridors touch several of the wards that connect to Downtown enabling benefits to accrue from the Corridors enhancements to be shared throughout the City.

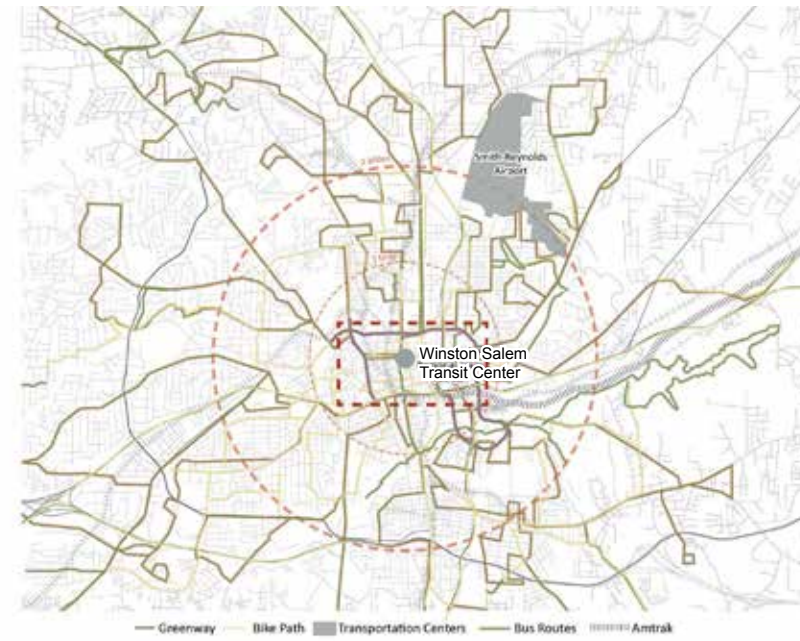

## City Transportation

The Piedmont Area Regional Transportation (PART) system links Winston-Salem to the Region, including Greensboro. The Winston Salem Transit Authority manages the city-wide bus system. Winston-Salem also has a bike lane system that crosses the Corridor, linking it to the rest of the City.

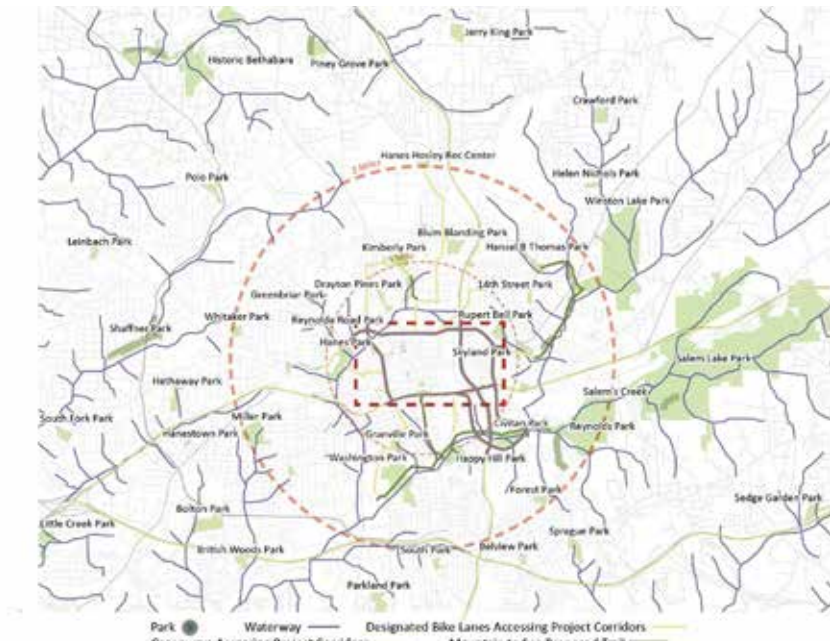

## City Greenways, Parks and Open Space

Several open-space networks and greenways touch the study area. The "Strollway" passes under Business 40 linking Old Salem to Winston-Salem. The Strollway links into the Salem Creek trail network which eventually links with the Mountain to Sea trail.

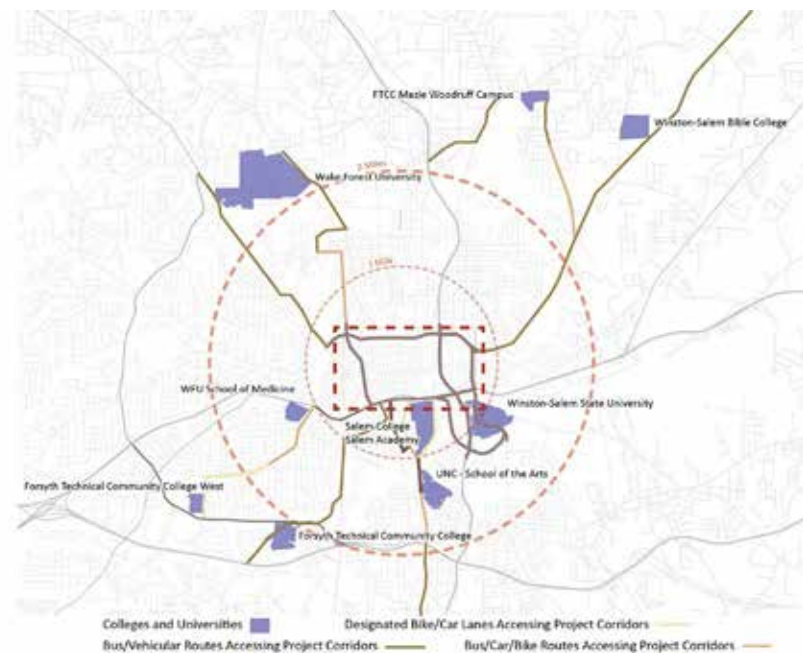

## City Higher Education

Winston-Salem has an extraordinary education infrastructure that helps fuel the economy and position it as a knowledge-based place. Winston-Salem State University, Salem Academy and College, Wake Forest University and UNC School of the Arts are all positioned near the Corridors.

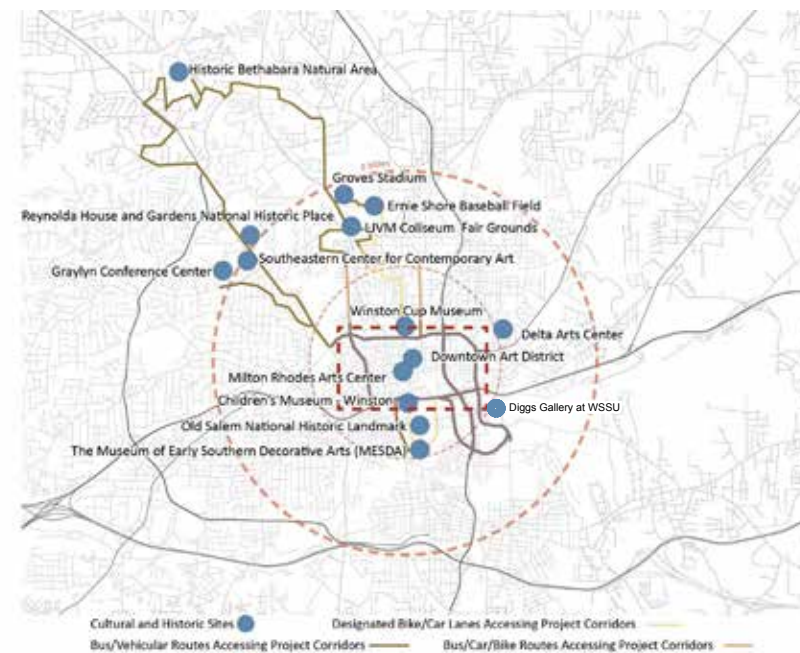

## City Cultural Centers and Museums

Winston-Salem has many significant cultural centers that establish an image for the City. Many of the sites line up in a north-south direction that passes through the Corridors suggesting a priority for that orientation.

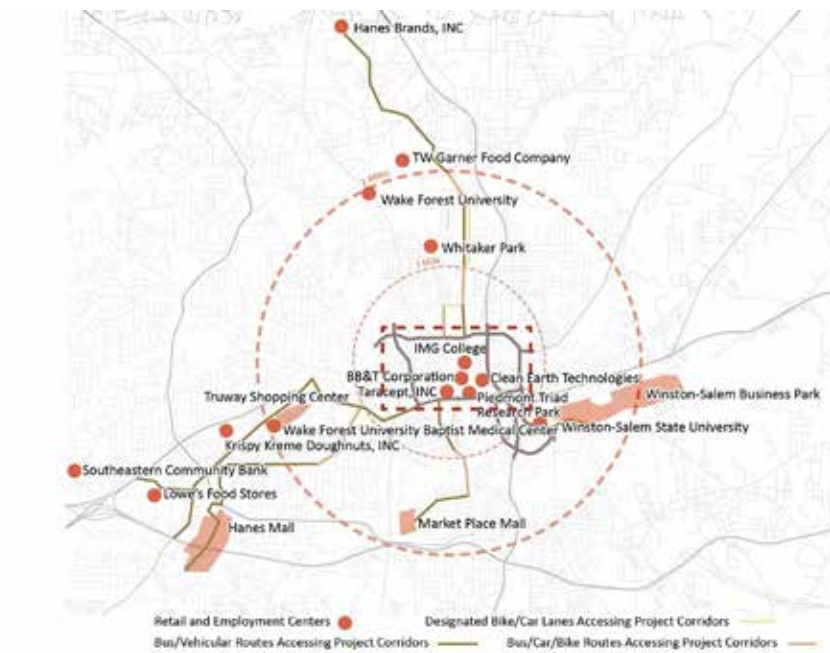

## City Employment Centers

Winston-Salem is a business hub for the region. Historically the major industries have been banking, tobacco, textiles and higher education. Recent efforts have brought focus to research- and knowledge-based jobs to replace jobs lost in the textile and tobacco industries. Many of these new jobs are located adjacent to the Corridors.



# CONTEXT - CITY SCALE

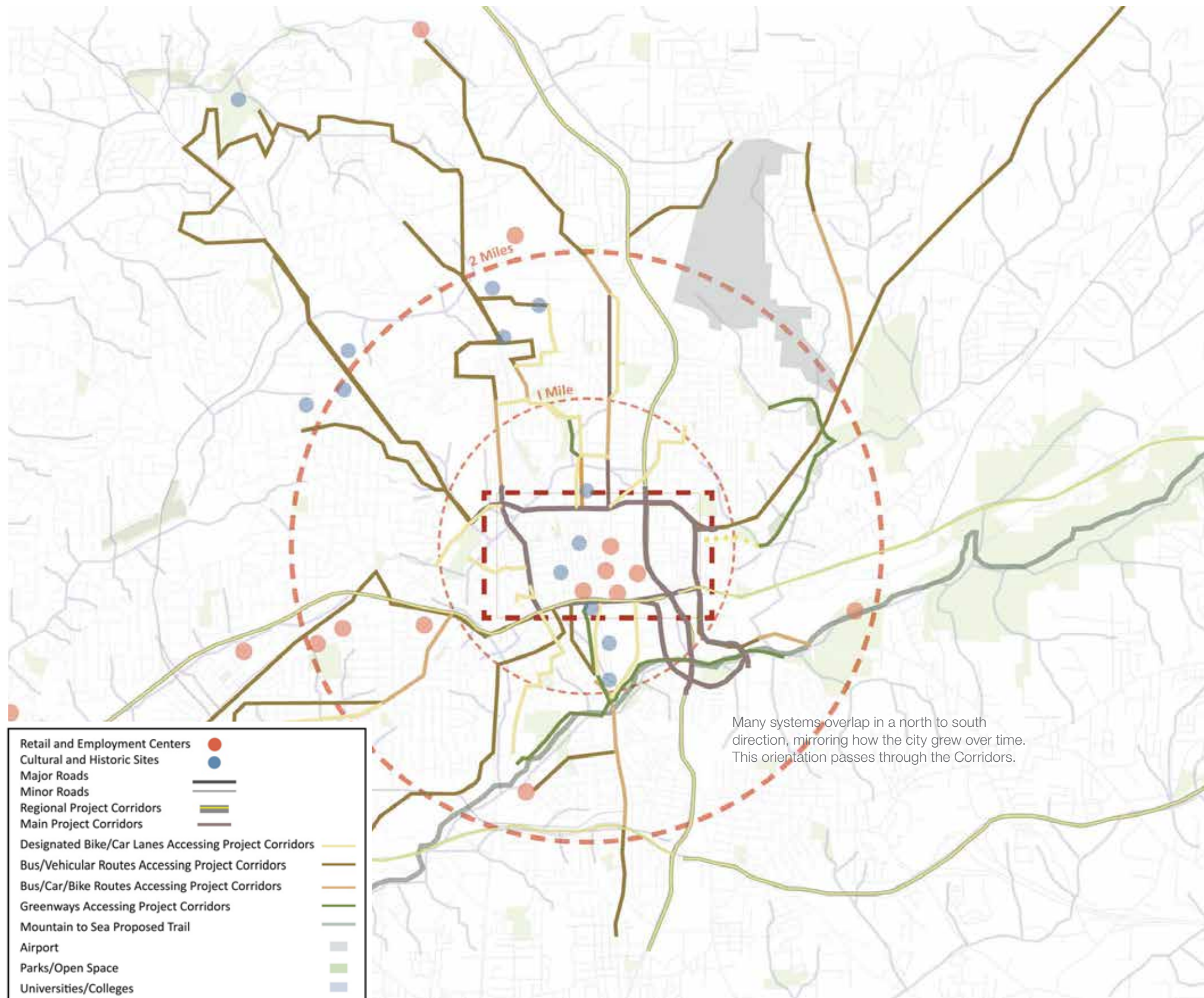

## City-Scale Context

Considering the Corridors as an integrated network, and not as a collection of unrelated individual roads, will enable the design to trigger economic, social and mobility benefits to the City.

Winston-Salem's unique history, culture and natural resources inspire the organization and themes of the project. While the transportation corridors divide the City's neighborhoods from each other, they also provide important linkages between them.

The maps on the previous pages reveal opportunities to link multi-modal transportation systems throughout the Corridors. For instance, the Strollway can be extended throughout the City, completely linking the City north to south with an enhanced greenway network. The design of the Corridors can magnify this feature. The streets that link the City north to south and east to west as well as the pedestrian and bike connections can also be highlighted so that these linkages are celebrated and promoted.

Additionally, the contextual analysis included in this document points to the opportunity to further Winston-Salem's position and role within the regional economy by the way in which the design is considered and executed. The design can contribute to expanding the City's branding efforts, maximizing a sense of livability and a sense of place and promoting an image that is reflective of the City's heritage and future aspirations.



# SITE PHOTOGRAPHY KEY MAP

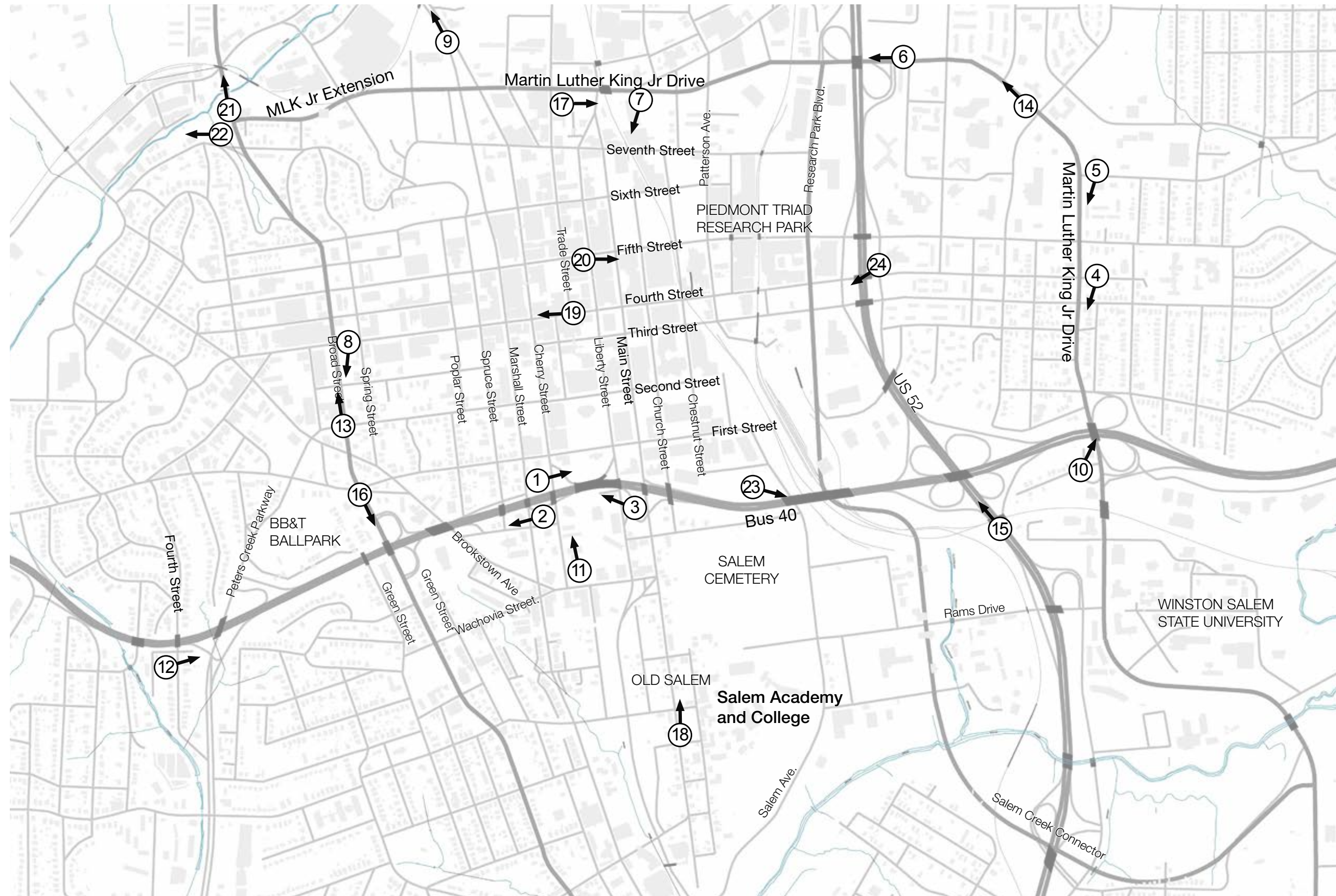



# SITE PHOTOGRAPHY

Photographs of existing conditions from various places around the Corridors reveal the need for artistic and design improvements to be considered comprehensively in order to improve the visual appearance and sense of place.



① The aesthetic experience of the Corridors would be enhanced with a cohesive design idea that creates consistency in the bridge forms and establishes a treatment for the center median that links the Corridor together.



② The absence of a center median treatment and lack of finished landscape on highway edges detract from the aesthetics of the Corridor.



③ Where Old Salem and Downtown meet is an important place in the City. It should be emphasized in the plan with a signature treatment. Billboards and lack of center median treatment detract from the aesthetics.



④ Third, Fourth and Fifth Streets on MLK Jr. Drive are important gateways, signaling access into the City from the east. The aesthetics suffer due to lack of streetscape and pedestrian treatments. The overhead power lines and lack of signal poles also detract.



⑤ The intersections on MLK Jr. Drive lack clarity for the pedestrian. Consistent intersection treatments that feature the pedestrian, along with street landscaping, will calm this busy roadway.



⑥ The transition from MLK Jr. Drive under US 52 creates opportunities for expression since it is one of the City's gateways. Currently, it presents itself as a barrier.



⑦ Another node in the City where people enter from the north is at Main Street. Design attention needs to be paid to the intersection in terms of planting, fixtures and paving. Including these would give this entrance a sense of hierarchy within the Corridors.



⑧ The Fourth Street area on Broad Street has seen redevelopment into mixed use. This is an appropriate response to this node. The area could be improved with intersection treatments and consistent landscape and fixtures. Reducing the amount of overhead power lines would also help the aesthetics.



# SITE PHOTOGRAPHY



⑨ This view looking north on University Parkway shows a black fence separating road from sidewalk.



⑩ The view looking northeast at the interchange of Martin Luther King Jr. Drive and Business 40.



⑪ The view from Strollway looking north into Downtown with the Liberty Bridge in the foreground.



⑫ The view looking east at the Peter's Creek Parkway interchange with Downtown in the background.



⑬ The view looking west along Fourth St from Broad Street.



⑭ The view looking west taken from the center planter on Martin Luther King Jr. Drive.



⑮ The view looking north on US 52 at the interchange with Business 40.



⑯ The view looking south on Broad Street.



# SITE PHOTOGRAPHY



⑰ The view looking east on Martin Luther King Jr. Drive at the intersection with Liberty Street.



⑱ The view looking north in Old Salem.



⑲ The view looking west on Fourth Street in Downtown.



⑳ The view on Trade Street.



㉑ The view looking west on Northwest Blvd of the Rail Crossing and the intersection with Broad Street.



㉒ A view of drainage from Broad Street.



㉓ The view of the bridge on Business 40 that crosses the existing Railline and Salem Avenue. This is the future location for the Salem Creek Connector.



㉔ The view looking west of the Fourth Street Bridge with Downtown in the background.



## CONCEPT DIAGRAMS - FOUNDATIONAL RELATIONSHIPS

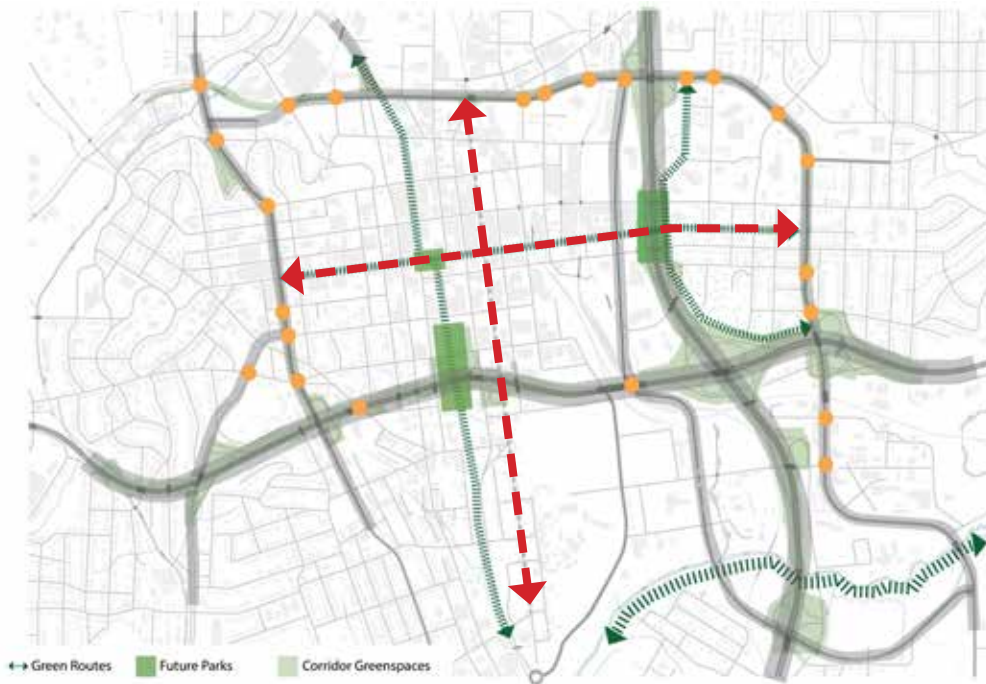

Create a “**Green Artful Iconic Network**” that encircles the City to create a powerful image and tie its districts and neighborhoods together. A green artful iconic network includes consistency in treatments around the Corridors, features that tie the Corridor together such as uniform treatment of the center median and structures that relate to each other in form and material, signature elements in key locations, and a landscape foundation that ties it all together.

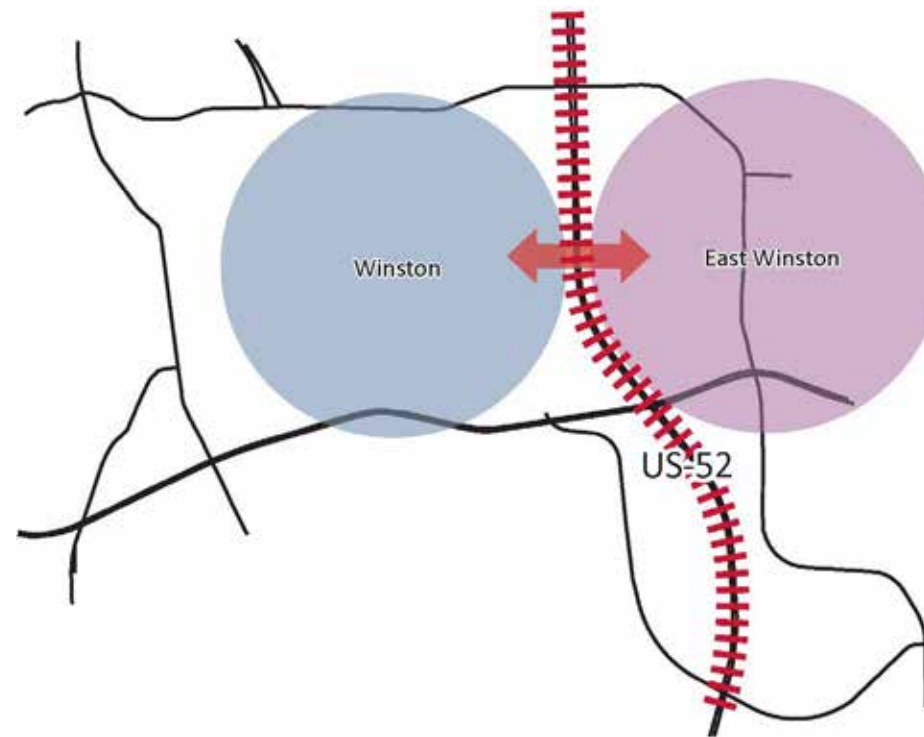

Enhance and celebrate vital connections between East Winston and Downtown. The enhancement of these connections will help to recognize the impact that the construction of US 52 has had on separating East Winston from the traditional City Center. The ideal location to create this enhanced connection is between Third, Fourth and Fifth Streets on the existing bridges. While there is no current plan to replace those bridges, the Master Plan recommends interim treatments that will make them more aesthetically pleasing.

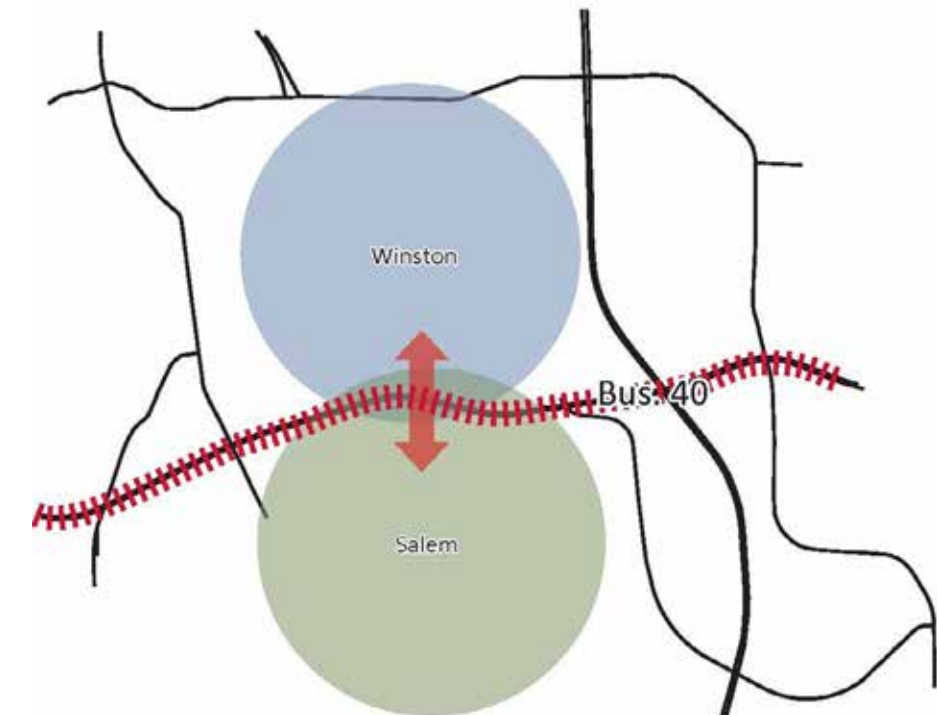

Acknowledge and improve vital connections between Old Salem and Downtown. Business 40 severed the sense of connectivity between Old Salem and the traditional City Center. The Strollway creates one component of linkage, along with the several bridges. Emphasizing the design of these bridges, along with the Liberty Street Bridge, will bring a higher level of visibility to this important place in the City. Creating a park at the Strollway location will further emphasize this location's importance.



# CONCEPT DIAGRAMS – ART ORGANIZATION

The framework for the design and artistic narrative revolves around an exploration into the past, present and future of the City. The past is generally expressed in the areas below the bridges. The future and concepts of innovation and aspirations are generally expressed above the bridges. The past meets the future in the present, which is generally

expressed in the contemporary design of the structures and fixtures that make up the Corridors. Encircling the entire composition is an expression of landscape and nature that surrounds the City and creates a calm and pleasant environment for the Corridors' users.

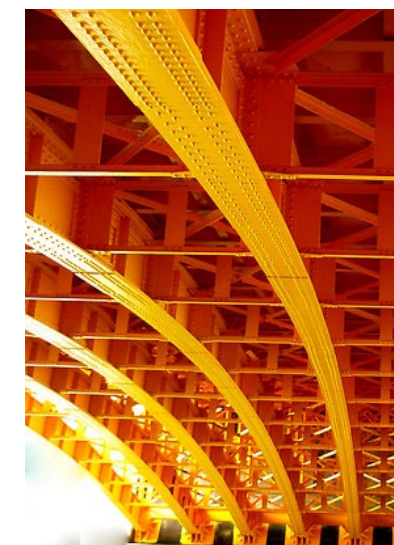
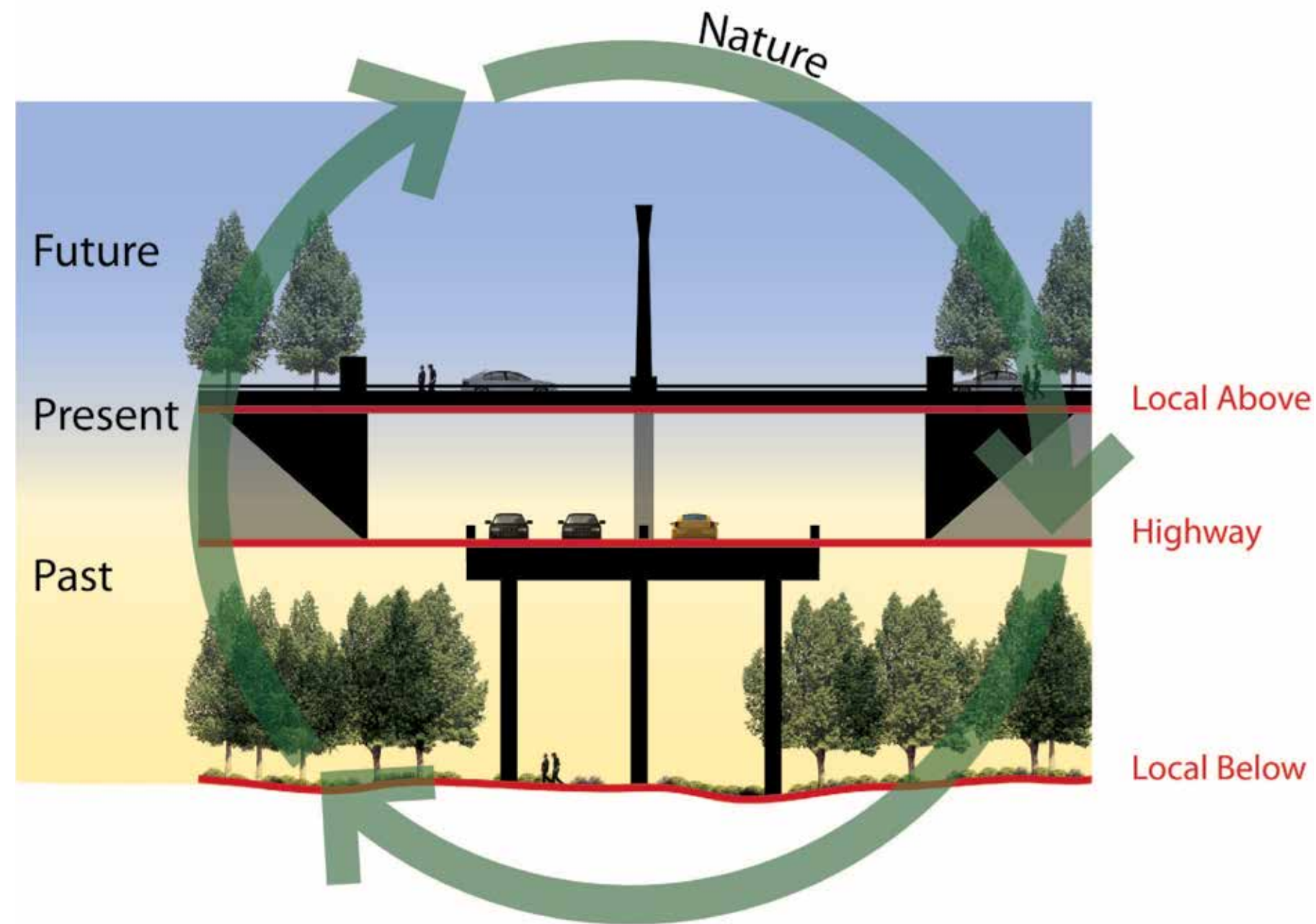

Future  
↑  
-----  
↓  
Past



# DIAGNOSTICS



**① The Corridors**  
The Corridors encircling the City create opportunities for landscape and aesthetic treatment that tie the City together.

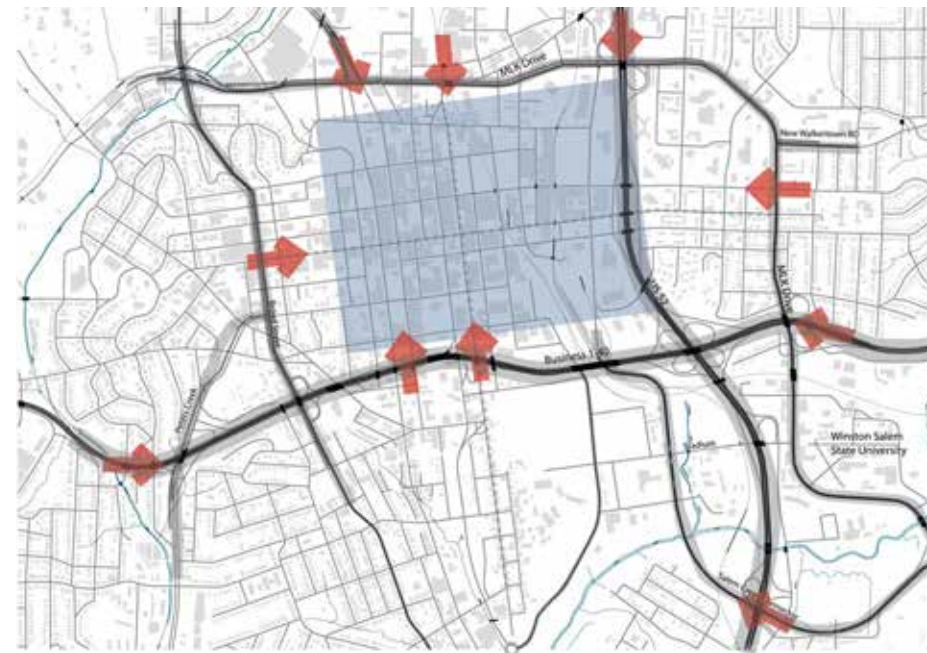

**② Entrances**  
Drivers along the Corridors enter Downtown through various locations along the Corridors. Design emphasis shall be placed on these entrances.

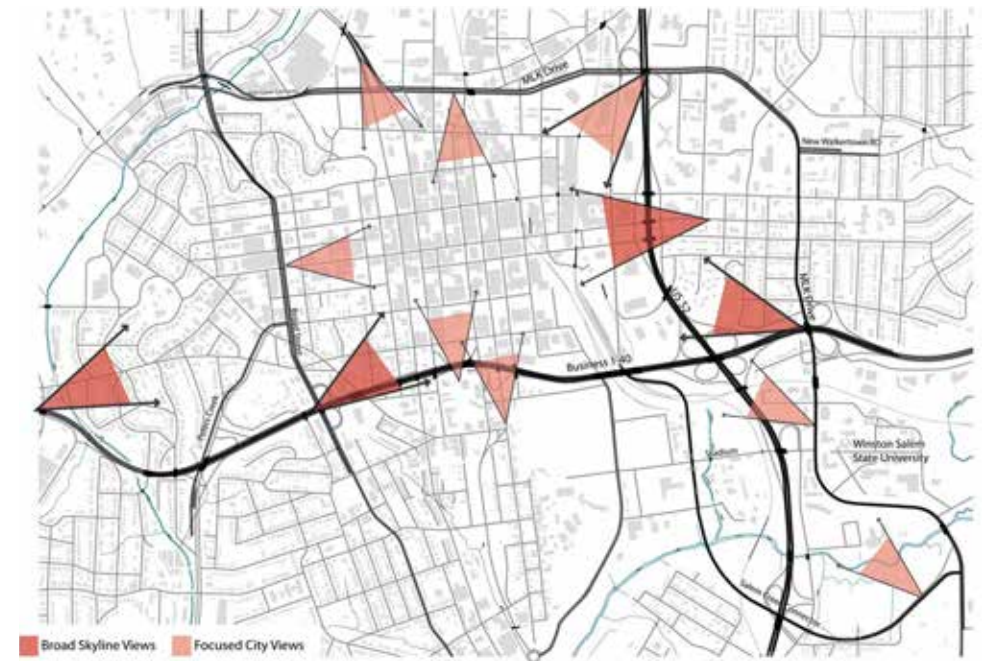

**③ Views**  
The Downtown is viewed from several points along the Corridors. Design emphasis needs to respond to and capitalize on the hierarchy of views.

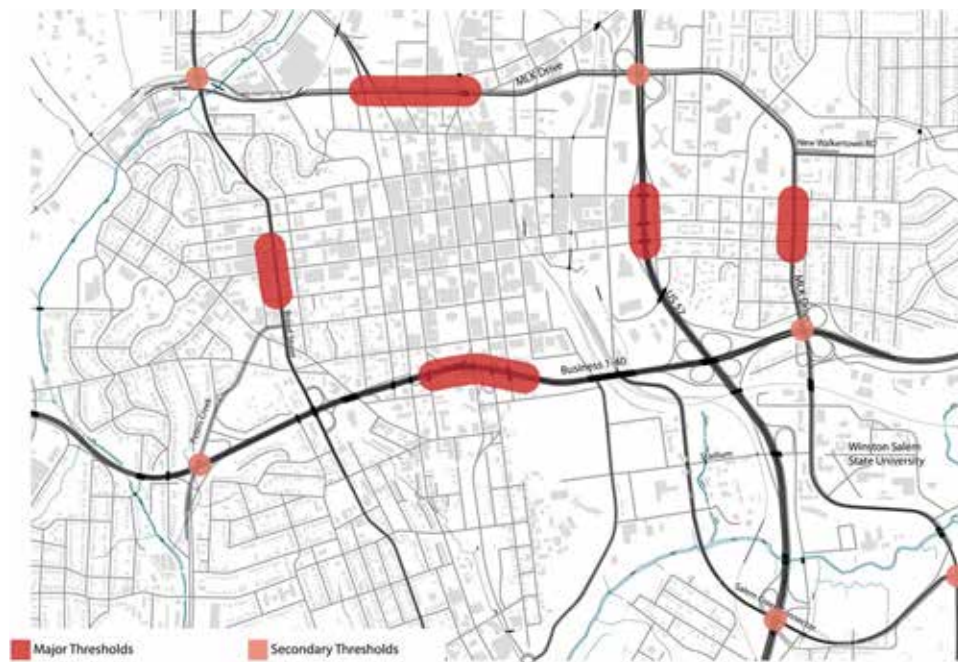

**④ Thresholds**  
Several locations that overlap with the major entrances to the City offer the opportunity for enhanced treatments in order to highlight their importance as part of the Corridor.



**⑤ Elevation**  
The Corridors rise and fall with the topography. The Highways tend to be experienced within channels cut into the topography creating a feeling of being below the City.



**⑥ Hydrology**  
The natural hydrology of the City creates opportunities for enhanced and artful stormwater management collections that create landscapes.



# CONCEPT DIAGRAMS - EMPHASIS ZONES

Several planning Layers overlap to create a hierarchy of emphasis within the network of Corridors. As the diagram suggests, emphasis is placed at the entrances into Downtown, as well as at the key places between East Winston and Downtown and between Old Salem and Downtown. This hierarchy of different emphases will influence how the structures and landscapes are patterned and

where higher levels of design integration shall occur. By highlighting the key areas of the Corridors with emphasis, a dynamic experience can be created and natural wayfinding can be revealed. A person driving, biking or walking in the Corridors will sense where the important passages are within the overall narrative of the Corridors.

## Diagnostics

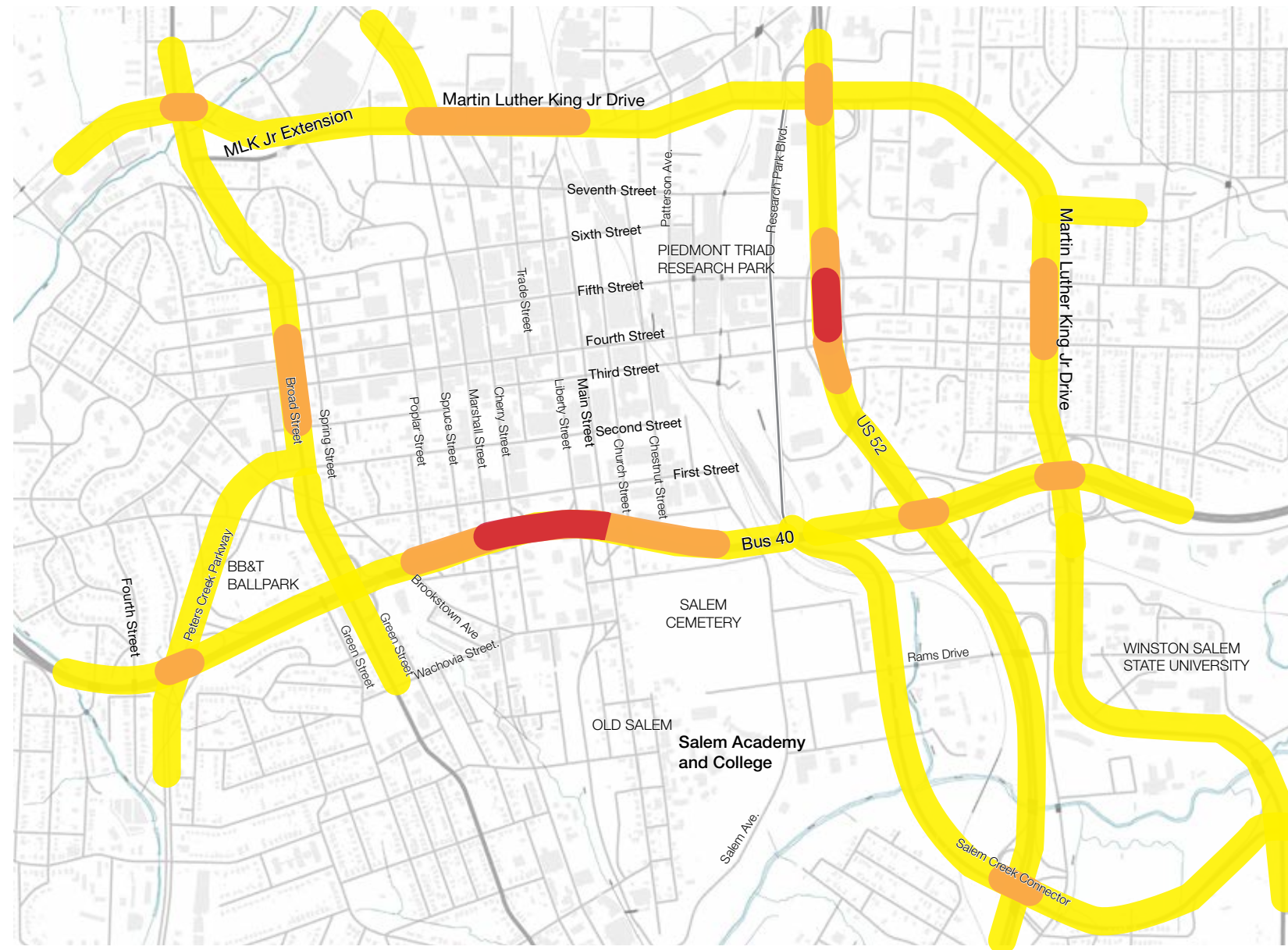
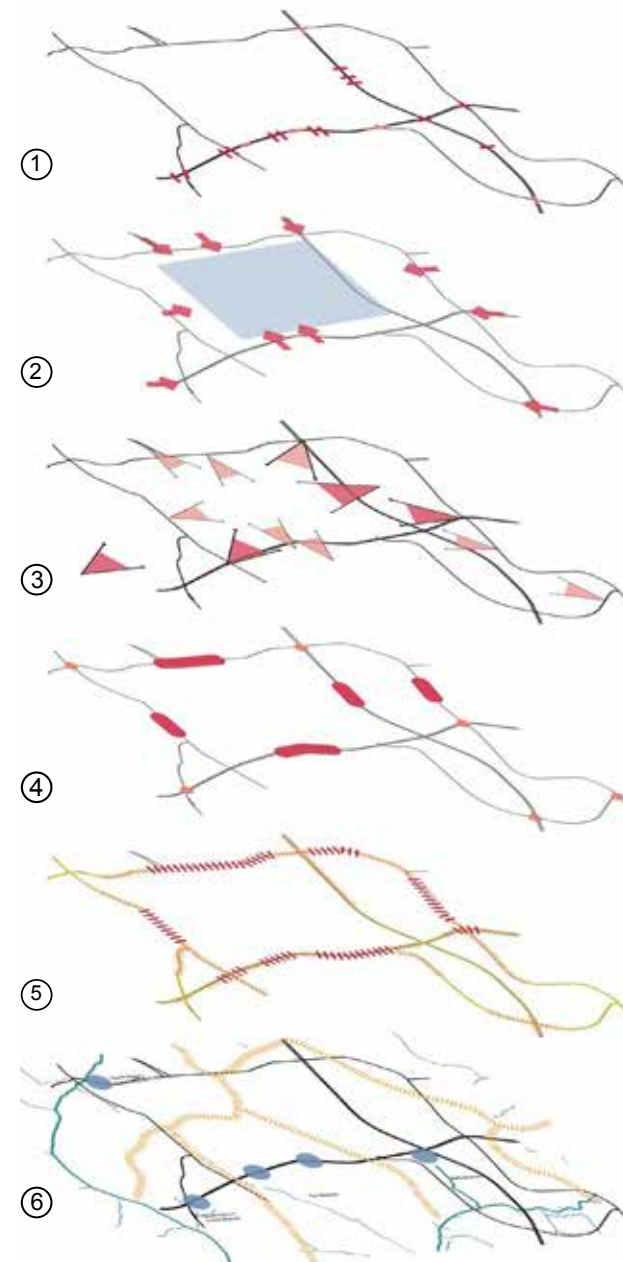

**Enhanced Zone** will have consistent details and finishes that tie the Corridors together and are better than the NCDOT standards for aesthetic design and integrated art.

**Focal Zones** occur at key points in the Corridors where travelers commonly pass through and/or travel in and out of Downtown. The focal areas will have refined materials, planting and integrated art.

**Signature Zones** are the most highly refined. Occurring at the most critical points in the City, their overall composition will create an iconic image for the City. In these areas structures and elements are designed as artistic expressions.





 Green



 Artful



 Iconic



 Network



# 3

## VISIONARY MASTER PLAN

From the time of its founding, the unique history and culture of Winston-Salem has been shaped by changing circumstances. The execution of this Visionary Master Plan can achieve what the community has asked for:

- Rebuild the Business 40 Corridor as a special and unique place;
- Alter US 52 in such a way that it is no longer regarded as a divider of the community;
- Expand economic development along Broad Street and around BB&T Ball Park;
- Enable Martin Luther King Jr. Drive to realize its potential to rearrange the order of the City and to affect where municipal priorities are focused.

The result will be a green, artful, Iconic network that will bring the City together, uniting Downtown and adjacent neighborhoods with a harmonizing set of artistic expressions and transportation experiences.

Seen as one whole, integrated system, the Corridors can provide a series of visual cues that will communicate where the main gateways to the City are, highlight important landmarks and areas, and aid in navigation. The intuitive travel experience that will emerge will elegantly reveal the personality of the City to travelers and residents alike, helping to define the City of Winston-Salem and to celebrate its unique character.

Arterial streets can help integrate pedestrian mobility and carry out the aesthetic design of the whole Corridor. The rebuilt Business 40 and US 52 can help re-define area walls and bridges as an integral part of the City's architecture.

This process can help heal old divisions within the City, allowing it to emerge with an aesthetically pleasing, integrated system of highways the like of which no other American city has yet achieved. These well-planned, green Corridors can become prominent and lasting symbols of Winston-Salem and an inspiring model of innovative urban redesign for other urban areas to emulate.



# BRIDGE TYPES & EMPHASES

The Bridges will be created, or reconstructed, as one of the following types:

**Enhanced Bridges:** These attractive, multi-span bridges (page 34) will have abutment walls, an enclosed center pier system and enhanced center and end pilasters. Where pedestrian movement occurs under the bridge, the abutment walls will be adorned with bas relief artwork that tells a story about the people who built Winston-Salem. On top of the center pilaster at pedestrian connection locations, a vertical art installation reaching toward the sky will address the theme of innovation. The end pilasters, which signal the entrance to the bridge, will incorporate artwork also, creating an attractive gateway at the pedestrian level.

**Focal Bridges:** The two types of Focal Bridges (page 35) will include additional opportunities for the integration of artwork at the pedestrian level. Focal Bridge #1 will be used at major pedestrian-accessible entrances to Downtown. They will be adorned with artist-designed arched canopies that shade pedestrians from the sun and frame views of the City. Focal Bridge #2 will have the same arched canopy and incorporate artwork on the abutment walls adjacent to the sidewalk.

**Pedestrian Bridges:** These bridges will be designed by artists in collaboration with the structural engineers.

**Signature Bridges:** The highest levels of artistic and structural integration will occur on signature, artistically designed bridges. They will have overhead arches that carry some of the structural load. These special bridges are reserved for the valued connections between Old Salem and the center of the City and between East Winston and the center of the City. From the analysis these areas were determined to be most important to emphasize. (page 36)

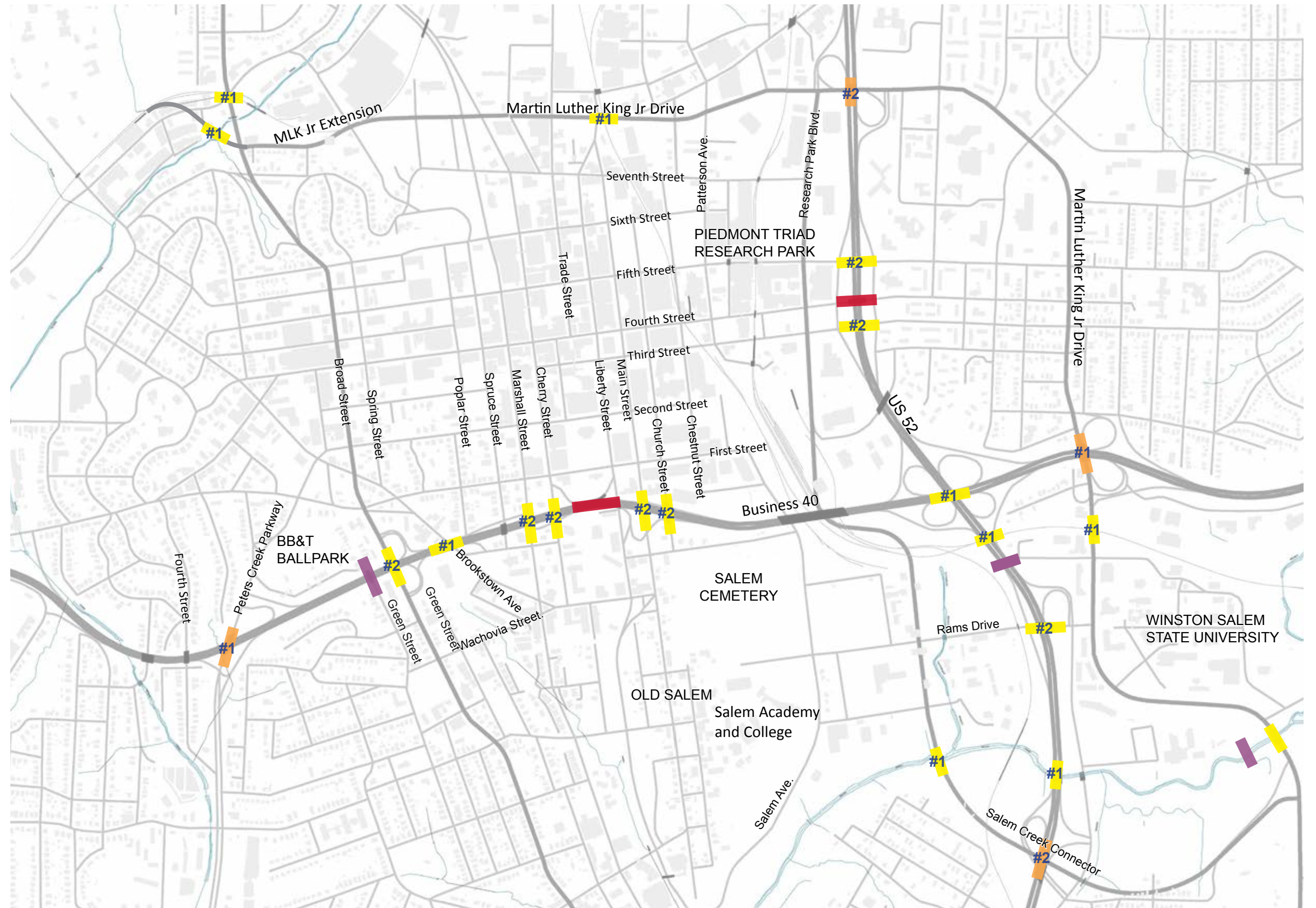



## BRIDGE TYPES & EMPHASES



### A Composition

The design of the Corridors includes Signature Bridges as well as Enhanced and Focal Bridges set into a landscape that incorporates a well-crafted and colorful median design that links the entire set of Corridors together.



## BRIDGE TYPES & EMPHASES



### Enhanced Bridge #1

The Enhanced Bridge is the typical bridge that will be constructed within the Corridors and elevates the typical bridge that NCDOT would normally construct into something that is more refined. When seen as a collection, these bridges will create a clean presentation and promote a sense of overall quality, while being respectful of design standards and construction methods.



### Enhanced Bridge #2

This bridge includes all the components of the "Enhanced Bridge" as well as locations for art that emphasize the center of the roadway as well as at either end. Combined with enhanced retaining wall materials and center median treatments, these bridges elevate the aesthetics of the Corridor.



## BRIDGE TYPES & EMPHASES



### Focal Bridge #1

The Focal Bridge includes all the components of the “Enhanced Bridge” as well as an artist-designed and engineered arched canopy that shades the pedestrian environment and frames views of the City.



### Focal Bridge #2

This bridge includes all the components of the “Enhanced Bridge” and has the highway passing over top of the bridge and the local street passing under it. Art is located on vertical walls next to the sidewalk that passes under the bridge, telling a story about the neighborhood that the pedestrian is entering.



## BRIDGE TYPES & EMPHASES



### Signature Bridges

Signature Bridge over US 52 at Fourth Street celebrates this important connection from East Winston.



Signature Bridges integrate the structure with artistic design. The arches that defines the Signature Bridges shall be designed by a bridge architect. These bridges are intended to be contemporary and ideally to promote an image that is unique to Winston-Salem.



# INSPIRATIONAL BRIDGES



Graceful and beautiful arcs stand in striking contrast to the horizontal driving surface.

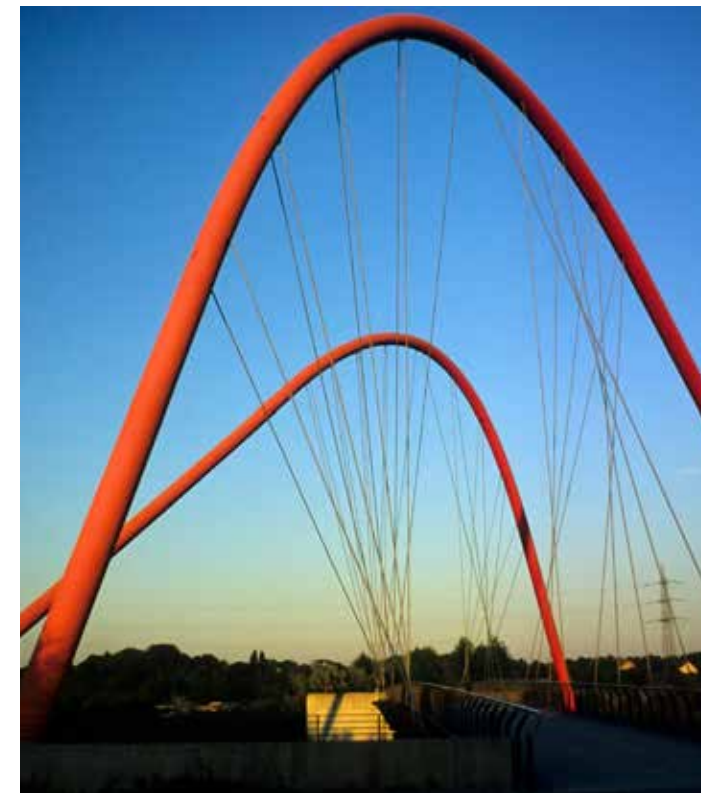

Attractive sinuous forms amplify this connection.

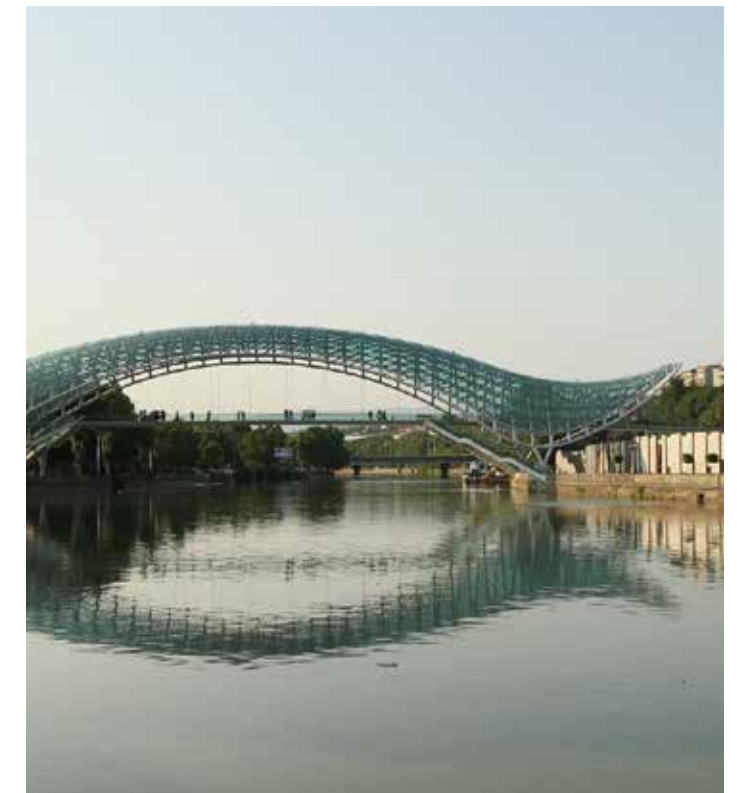

Organic flowing forms create a strong visual connection



Contrasting forms creates a memorable experience.

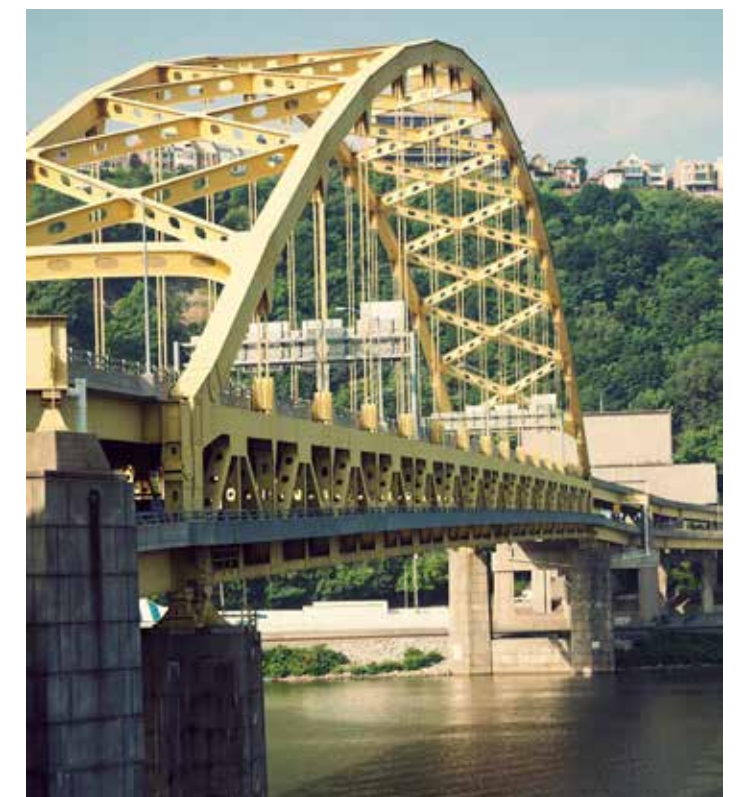

Classical forms are bold and embrace the identity of Pittsburgh.



# INSPIRATIONAL BRIDGES



A graceful bridge with an iconic element stand in contrast.



Bright colors and simple forms create a bold statement.



Tension is created in this artful and architectural composition.



Simple elegant forms create a clean contemporary effect.

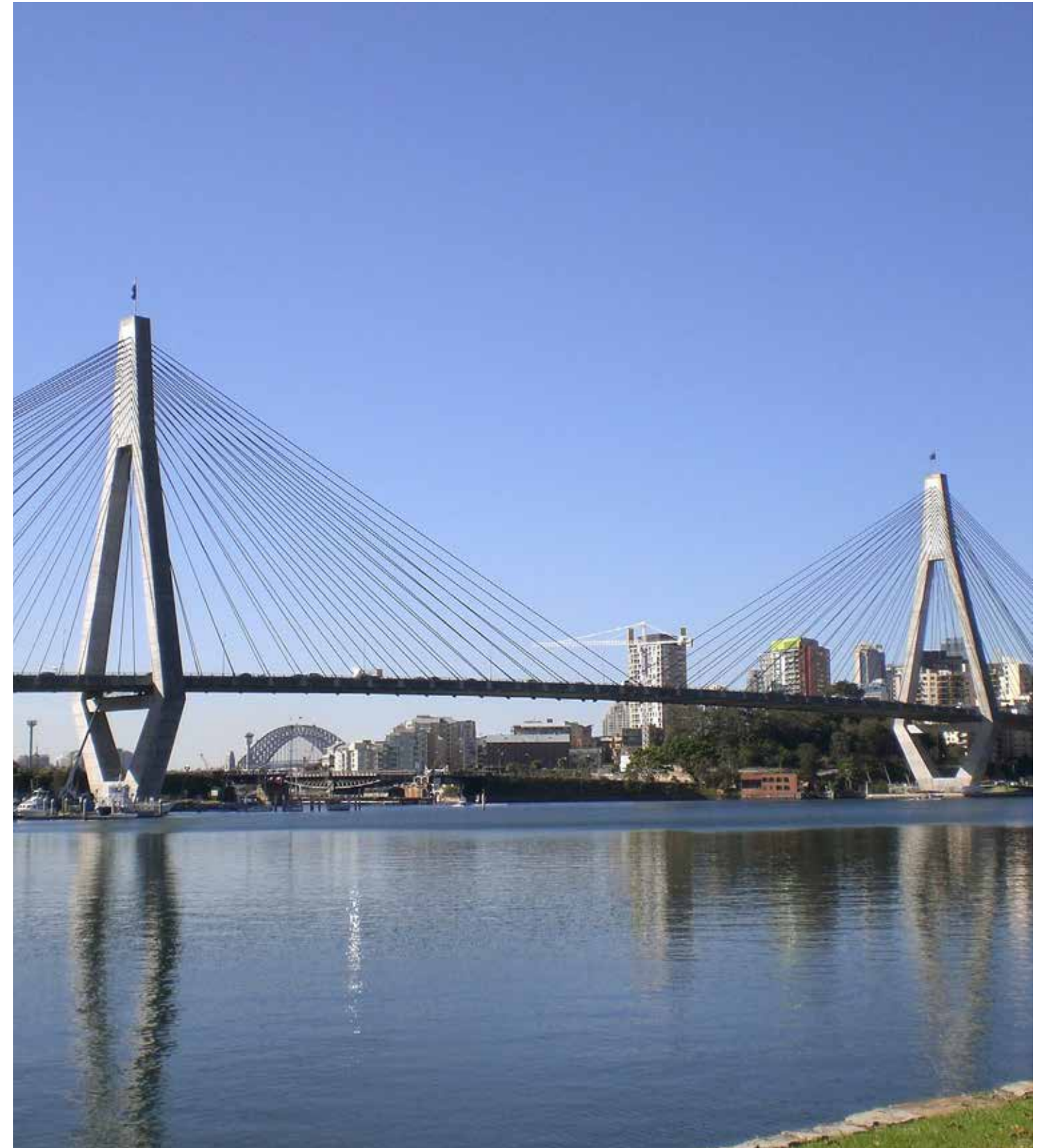

Bold and precise structural elements are iconic.



# INSPIRATIONAL PEDESTRIAN BRIDGES



Curving playful lines form an interesting composition.



Smooth curving lines create interest.



Steep and dramatic arches create the feeling of a gateway.

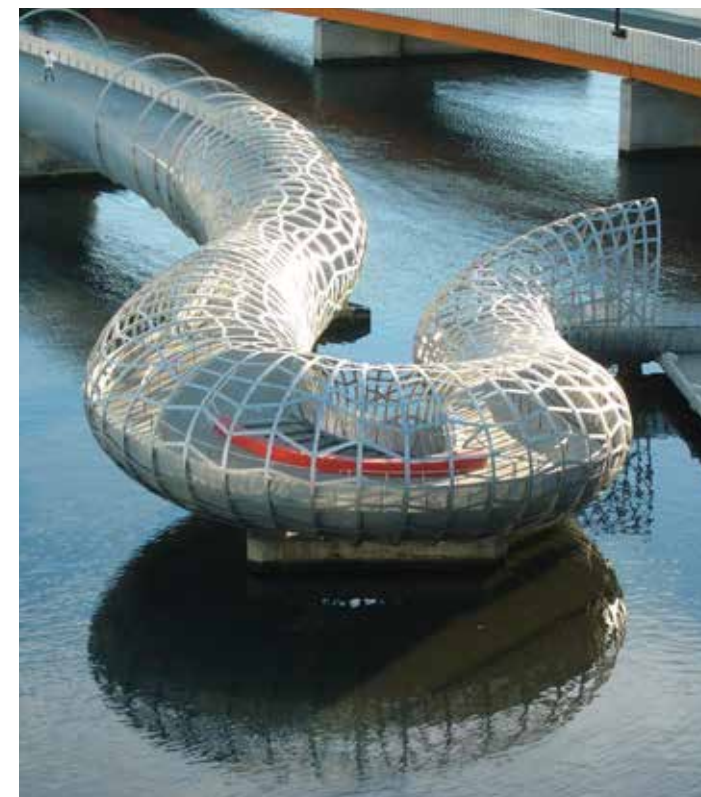

A unique experience is created with fun and original forms.

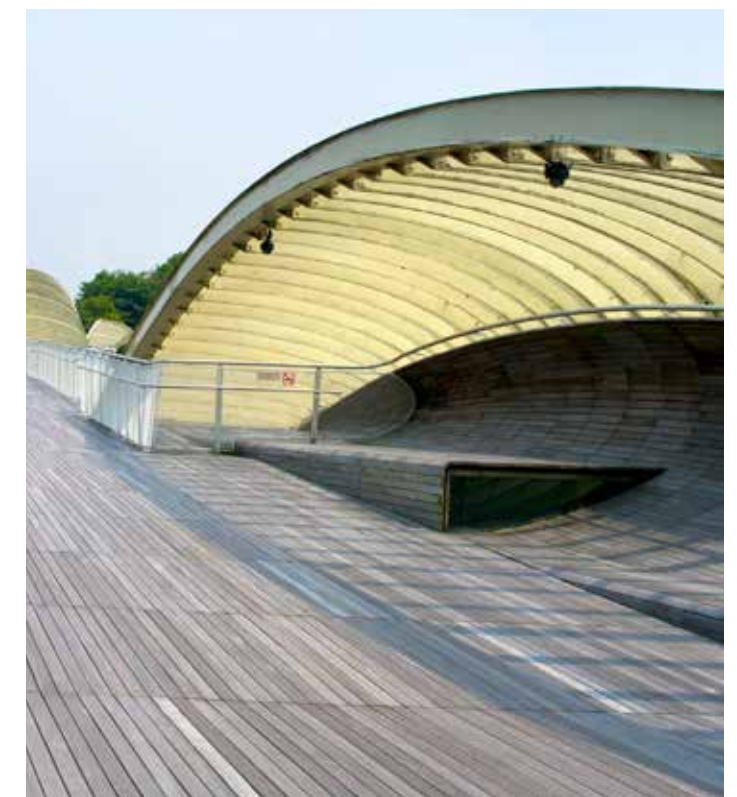

Pedestrian bridges can create spaces for people to gather.



# LIGHTING STRATEGIES



TO PAGE 38 (PG #?)

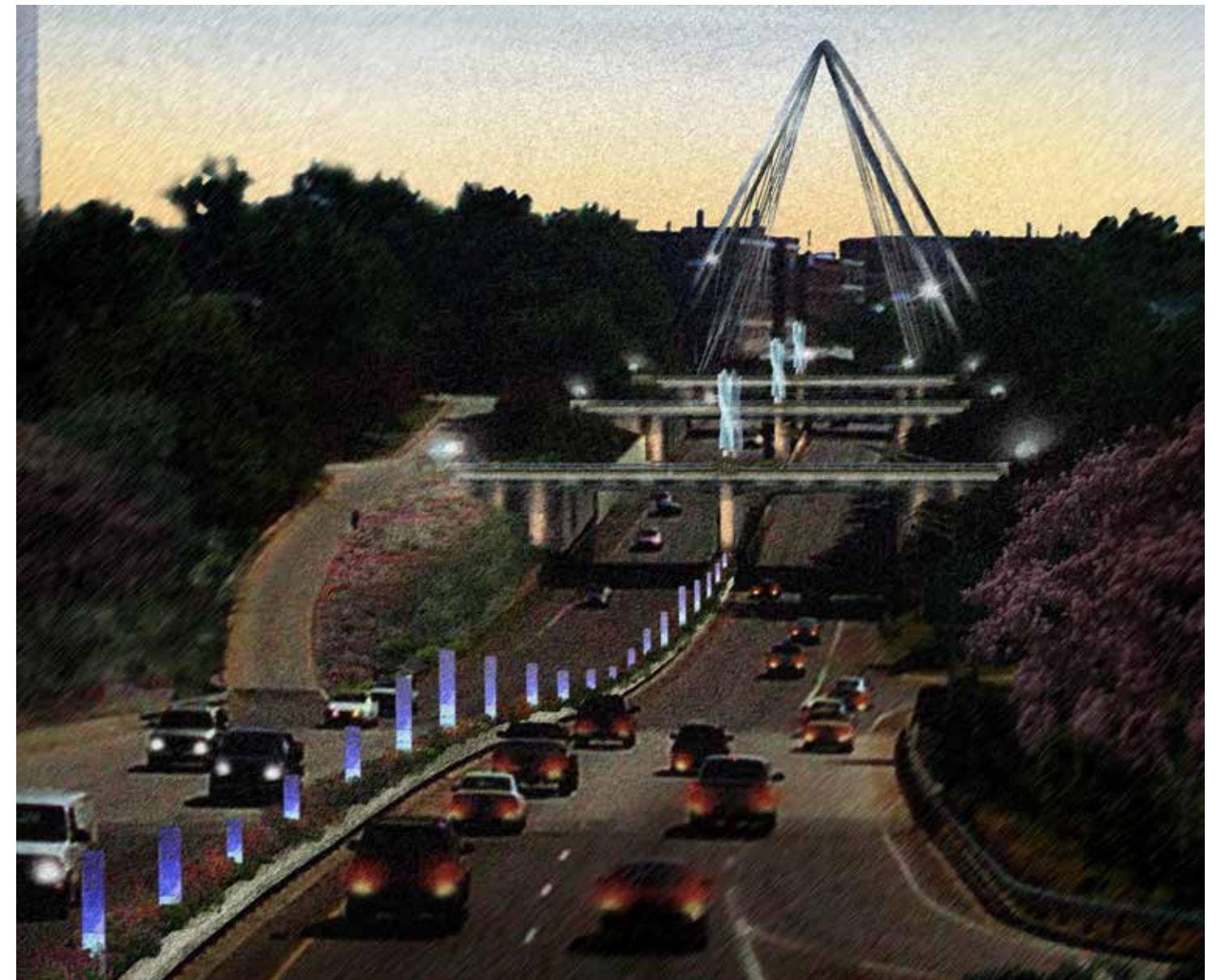

## A Corridor of Light

Whether planted or not, the median treatment can include artful lighting that ties the entire Corridor together and creates drama at night.



# INSPIRATIONAL LIGHTING STRATEGIES



High contrast strengthens the effect of this organic form.



Simple forms and surfaces can be brought to life with color.

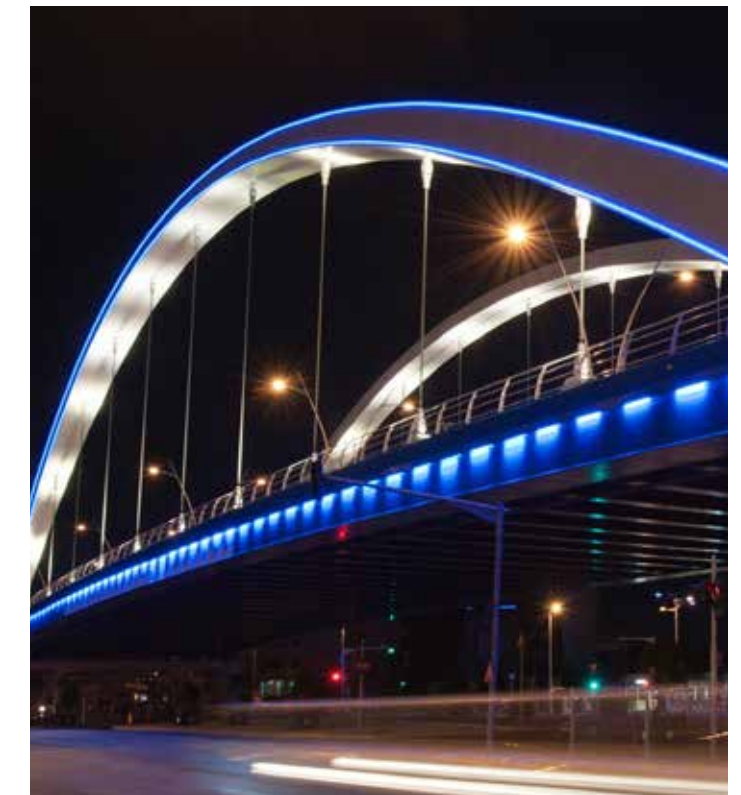

Highlighting elegant forms is a simple and effective lighting strategy.



Bold architectural forms are best when evenly lit.

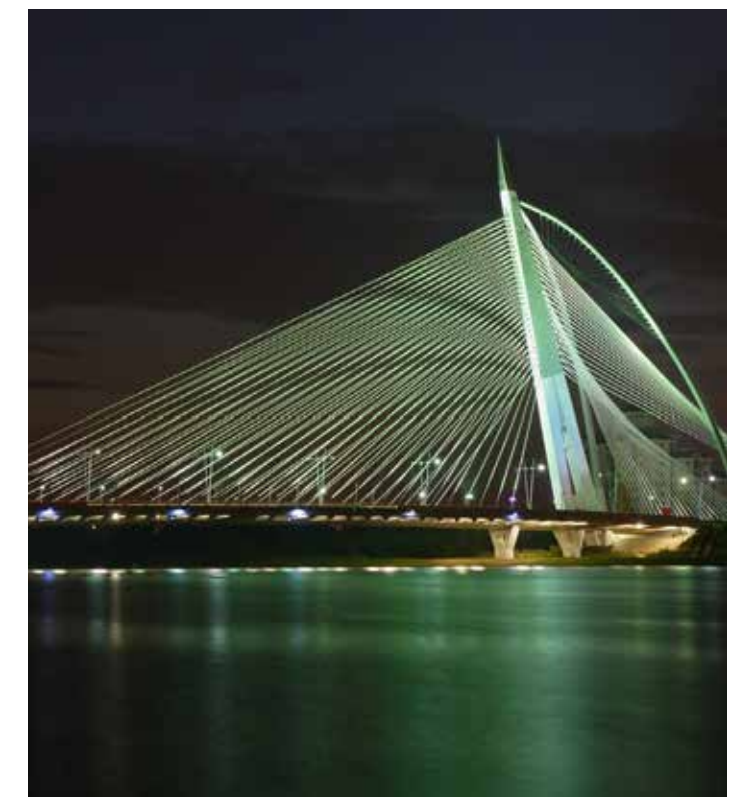

Light brings this strong composition to light.



# PEDESTRIAN CROSSINGS

The articulation of the pedestrian experience is a critical component in the project's design. While pedestrian travel is important everywhere, and should always be considered with careful attention to issues of both safety and comfort, designing stellar pedestrian travel is vital for some areas within the Visionary Master Plan. Pedestrian crossings will create hierarchy and wayfinding through the following:

**Major and Minor Thresholds:** These include provisions for enhanced landscaping treatments, special paving and enhanced outdoor furniture and art. They will mark major entrances into the Downtown area across the Corridors.

**Bridges with Enhanced Pedestrian Environments:** These will have provisions for enhanced sidewalk treatments, separating pedestrians from traffic with plantings, art or decorative furniture and fixtures.

**Neighborhood Linkage Zones:** These will include intersections on the arterial roadways that provide links between Downtown and surrounding neighborhoods and will include provisions for enhanced paving treatments and crosswalks, landscape, art, signage and light fixtures.

**Major Pedestrian Connections:** These will occur across the Fourth St. Bridge and under the Liberty St. Bridge, re-linking the City across the Corridors.

**Major Pedestrian and Bike Routes:** This will highlight important multimodal Corridors, including a proposal for a multi-purpose path along the Business 40 Corridor.

Remaining pedestrian crossings will receive adequate provisions for crosswalks, signage and landscape treatments so all pedestrian crossings are safe, attractive and comfortable.

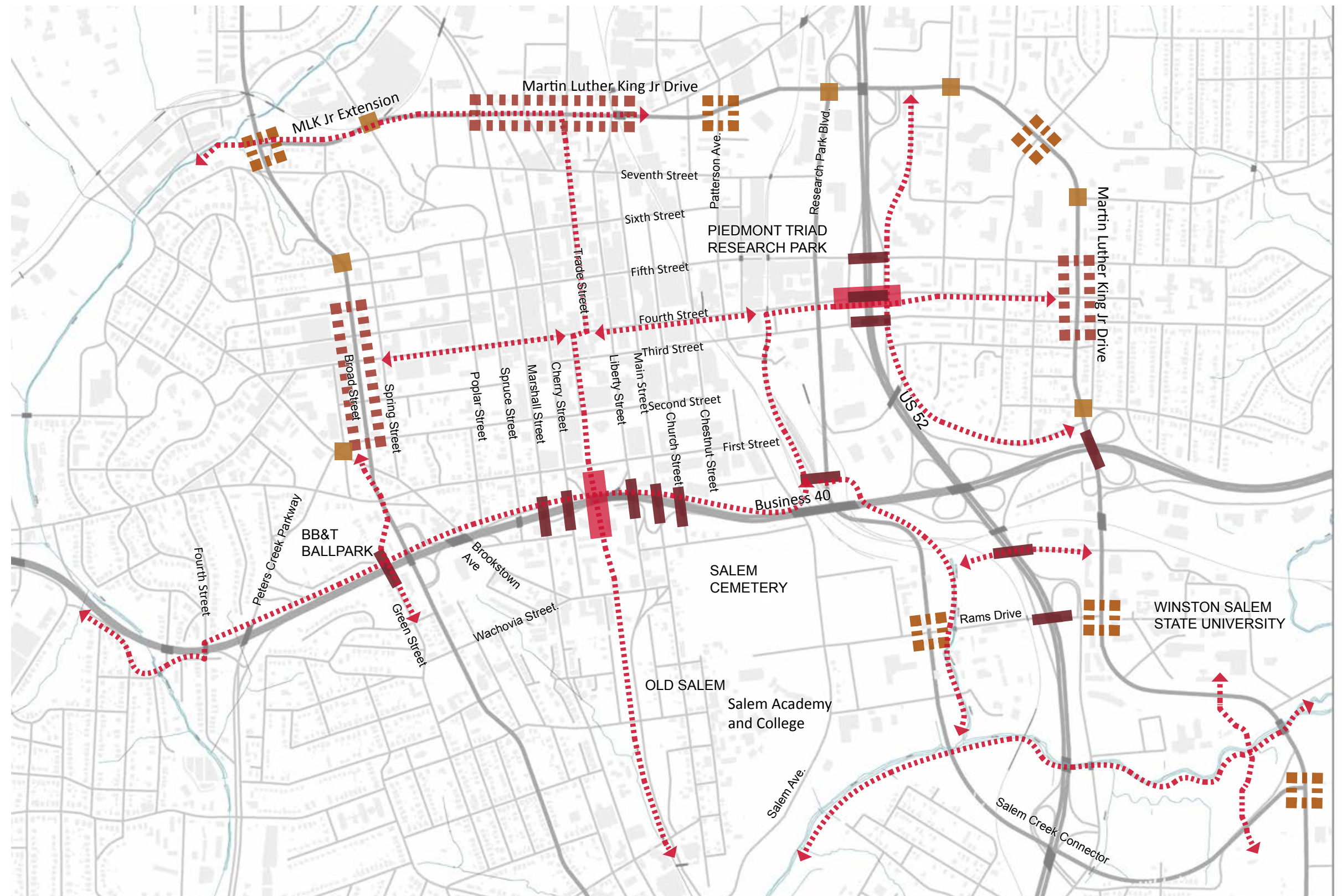



# PEDESTRIAN CROSSINGS



Example of **Enhanced Pedestrian Environment** on bridges that includes art installations, special paving and decorative plantings to celebrate the pedestrian environment.



Example of **Major and Minor Threshold** intersection with special paving in crosswalk area, decorative light poles and signal poles, pedestrian art, and enhanced landscaping.



Example of **Neighborhood Linkage** zone intersection with special paving in crosswalk area, story-telling art next to sidewalk and enhanced landscaping. The story-telling art narrates important events, people or history and also provides a buffer from the busy street.





# INTEGRATION OF ART

Art is a fundamental element in the Visionary Master Plan. While this plan does not prohibit additional art from being located within or adjacent to the Corridors, it does recommend that any such additional art respect the guidelines and components of the Visionary Master Plan. Public art will be organized into the following types:

**Artful Bridge Structures:** These may be artist-designed canopies, artful structural forms or artist-designed pedestrian bridges.

**Art on Bridge Elements:** Elements will include freestanding art and art integrated into key parts of the Bridges, including art placed on the end and center pilasters.

**Art within Intersections:** Artists will be involved in the design of paving patterns as well as the location of art on traffic poles and light fixtures. This art will closely align with the “Art Along Corridor” so together are parts of a single narrative.

**Art along Corridor:** These pieces will tell a story about each of the neighborhoods the Corridors pass through. Artful sign walls will run along portions of the roadway, art will be embedded into the sidewalks, and art will be placed on light fixtures.

**Art Integrated into Retaining Walls:** Form liner or artistic patterning of the masonry will be used to create the retaining walls.

**Art within Interchanges:** This will include vertical art pieces placed within the landscape.

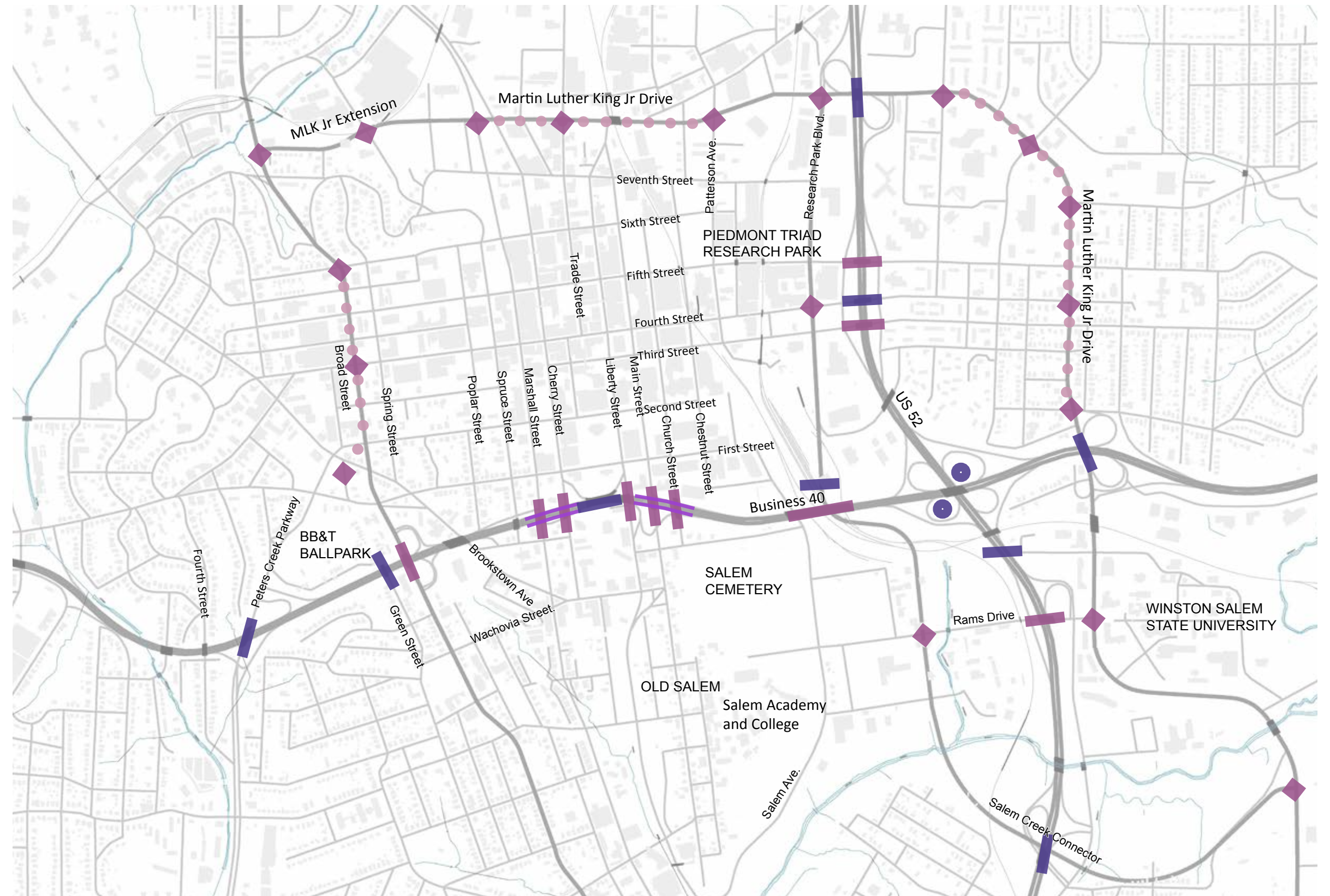



# INTEGRATION OF ART



Utilize dramatic lighting for the undersides of the bridges and medians to create a "Corridor of Light."



Utilize dramatic vertical art pieces that are illuminated to respond to concepts of Art and Innovation.



Use materials typical of Winston-Salem to inspire artistic interpretations and patterns on wall surfaces.



Enliven space under bridges with playful and surprising sculptures such as the "Troll" under Fremont Bridge in Seattle.



Use sculptural human forms, reflective of the people who have built the City, to "hold up the center of the bridges" on each of the center pilasters.



Integrate art into the design of structures such as the Linerty Bridge in Greenville, SC.



Enhance the pedestrian environment with artistic awnings and use artists to design the pedestrian bridges.



Provide artworks at the ends of the bridges that are meaningful to the neighborhoods. These can be permanent or rotating exhibits.



# INSPIRATIONAL ART INTEGRATION



A kinetic sculpture to catch the wind



Vertical metal sculptural pieces on center pilaster like by Viki Scuri



Fun and playful sculptures within the median



Vertical light sculptures like at LA Airport by Paul Tzanetopoulos

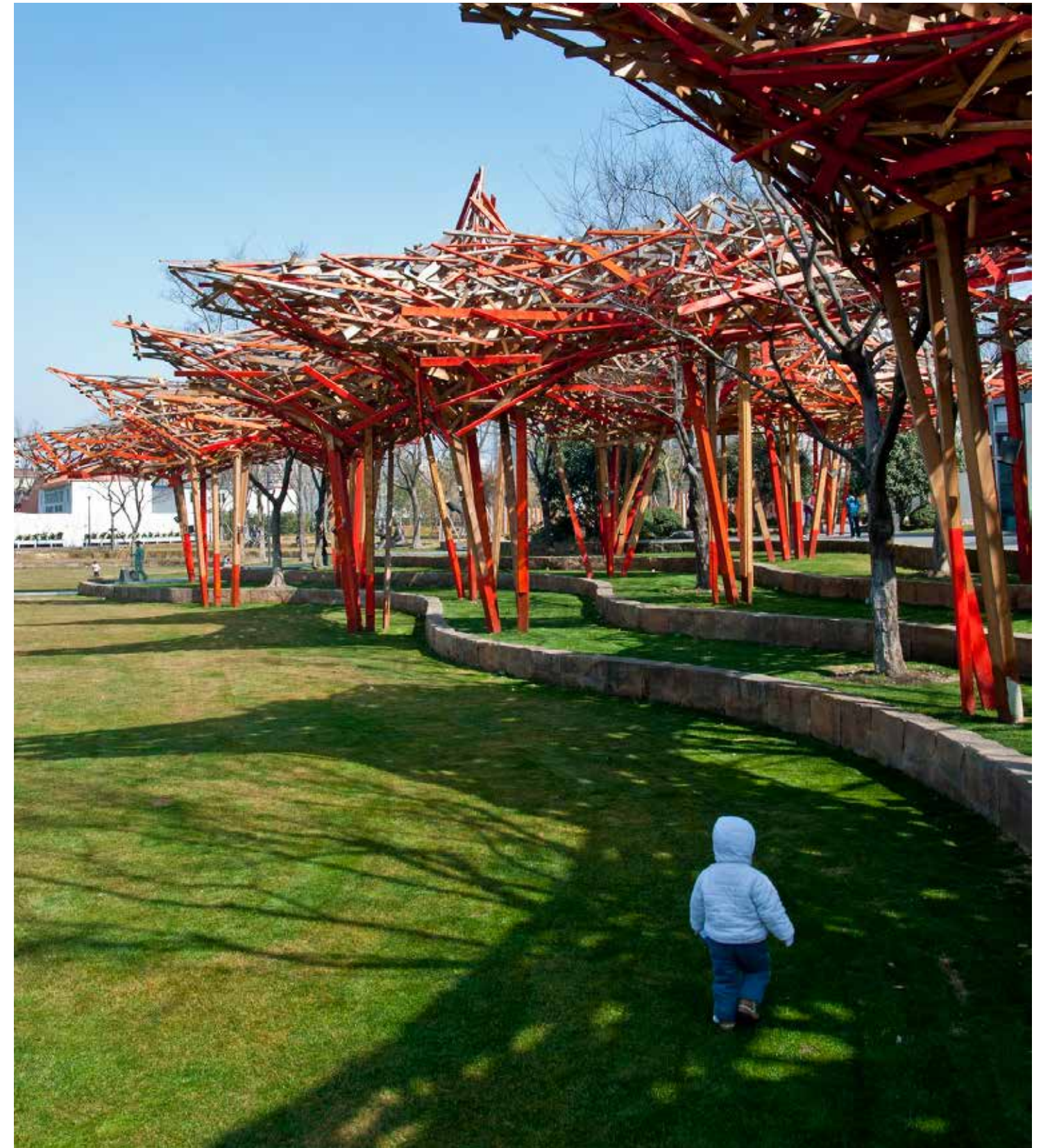

Art creates playful canopy within park areas



# INSPIRATIONAL ART INTEGRATION



Depictions of people or symbols that are meaningful to neighborhoods



Artful imagery incorporated into concrete installations



Art that tells stories about neighborhoods and people

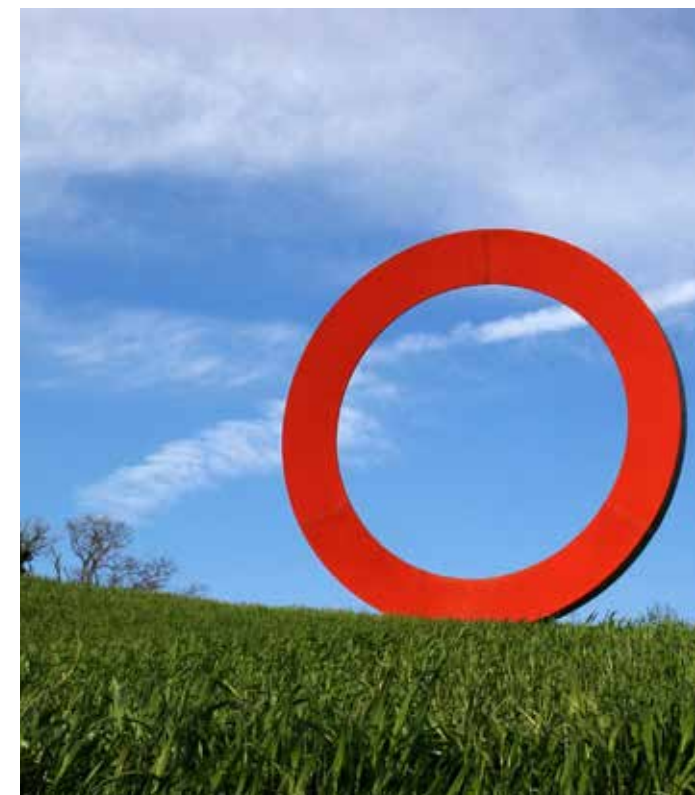

Freestanding art within landscape areas

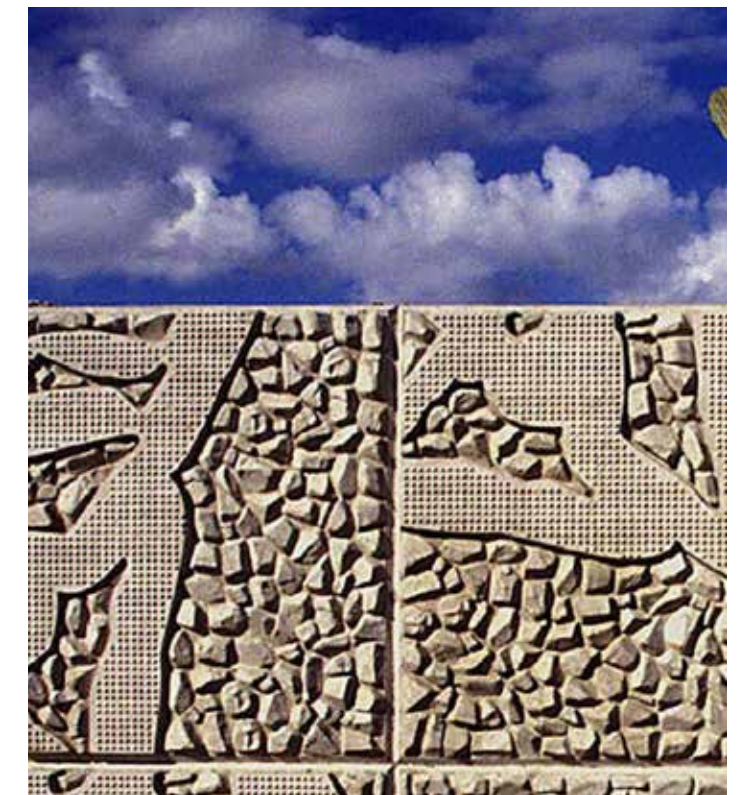

Wall textures by Vicki Scuri



# SPECIAL PLACES

Adjacent to the Corridors, there are several “special places” that can be either created or enhanced as part of this process. These “special places” will enable the City to make fuller and more meaningful use of the Corridors. They include:

**Liberty Park:** Underneath the Liberty Street Bridge is a currently under utilized open space. With the creation of a park in conjunction with the proposed Signature Bridge planned for this area, people can come together in a new public green space for performances or recreation such as skateboarding. Also, this park would offer an opportunity to regionally manage the new-found storm water artfully, allowing the water to become a foil for the dramatic bridge structure above.

**Third, Fourth and Fifth Streets Park:** The Bridge crossings of US 52 offer an opportunity to expand upon the plantings already being implemented by the City to create a new park that links East Winston across US 52 to the Research Park. This new park could utilize space abandoned by the removal of the area access roadways and could include new plantings and artwork. There will be similar improvements to the north and west.

**Third, Fourth and Fifth Streets Mixed Use:** Enhancing the streetscapes of MLK Jr. Drive as well as the bridges that traverse US 52 presents an opportunity to promote urban mixed-use redevelopment within this part of the Corridor, extending outward as far as it can be supported from an economic development perspective. This redevelopment could create a much-needed mixed-use destination within East Winston.

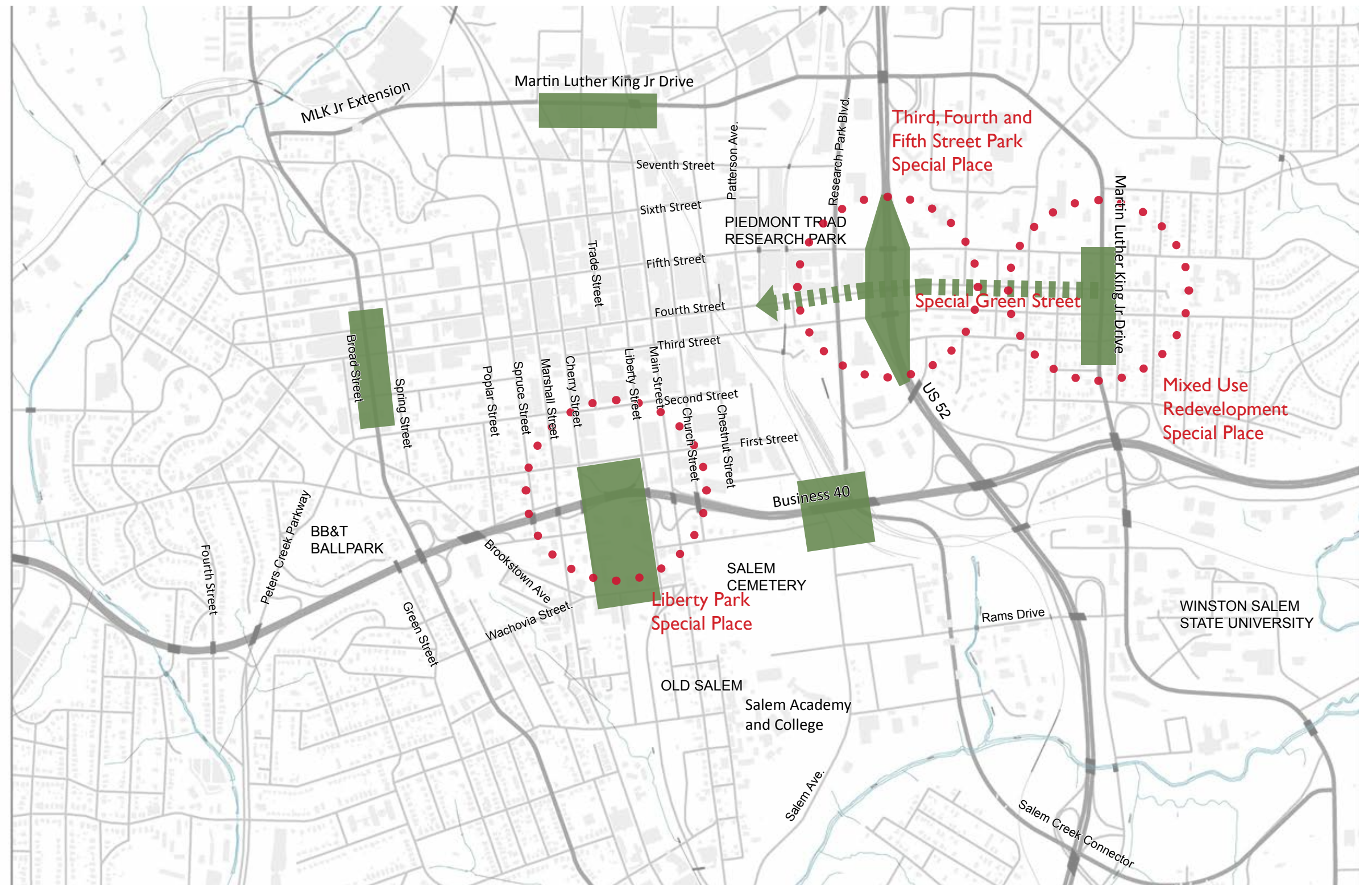



# SPECIAL PLACES



Liberty Park creates a special new space in the City and forms an open space core at the juncture between Old Salem and the downtown core. The Liberty Street Signature Bridge announces this important space in the City.



The spaces created under the bridges can become attractive at night or day using art, water and attractive lighting.



Art, design and technology can be integrated into how water is managed. Regional water management can become part of the aesthetic experience.



Recreational activities for youth such as a skatepark can attract a diverse group of people.



## SPECIAL PLACES



Special Place highlighted with enhanced streetscape elements such as seasonal canopy lighting.



Architecture should frame the street and include a retail element at the ground floor, as in this new building at Fourth and Broad Streets.



**Mixed-Use Redevelopment** between Third and Fifth Streets on MLK Jr. Blvd. Combined with Form-Based Code overlay, it creates a key redevelopment opportunity for this important place in the City. Similar mixed-use development will be encouraged along Broad Street from Second to Seventh Streets.



# SPECIAL PLACES



Third, Fourth, Fifth Streets Park with enhanced landscaping, curvy walls that welcome people across, reconfigured street cross sections, street trees and landscape on the bridges.



Sculpture Parks at either end of the **Third, Fourth and Fifth Streets Bridge**, along with enhanced pedestrian environment on top of the bridge, welcome people across.



Until the bridges in this location get reconstructed, the existing ones can be enhanced with planters or green screens that extend the idea of park across the highway.



# LANDSCAPE ZONES

The goal of the landscape plan is to establish a green network with consistently applied treatment and materials so that it reads as a whole, integrated network encircling the City.

Each Corridor and the existing environment that each Corridor passes through create places for design variation, emphasis and highlight. This map summarizes the different landscape environments that will be created.

- Traditional Streetscapes:** Along the arterial roadways, traditional trees, sidewalks and street furnishings will be provided.
- Threshold Landscape:** Landscape plantings, special paving, and fixtures will identify and highlight entrances into the City.
- Parkway Landscape:** The landscape of the highway corridor will have canopy and understory tree massings and planted medians.
- Gateway Landscape:** The major interchange areas will include massings of large trees and natural groundcover to create a visual impact.
- Lowland Landscape:** Plant types suited for wet conditions with minimal sunlight will be located in the areas underneath some of the major bridges. Planting these lowland areas with appropriate vegetation will signal the nature of their unique environment and will provide a visual accent distinguishing these areas from the rest of the landscape.





# LANDSCAPE ZONES



Within future street cross sections, consideration shall be given to providing water management landscapes along the edges of pavement.



Within the **Threshold Landscape** zones, the use of statuesque canopy trees along with buildings fronting streets signal these important spaces.



The vital street connection from East Winston along Fourth Street into Downtown should consider a street cross section and landscape treatment that becomes a highly pedestrian "garden street."



At appropriate locations, create a landscape for the street that includes canopy trees for shade and innovative storm-water management techniques.



Within the **Gateway Landscape** zones, grids of trees with native groundcovers underneath bring order across the varied topography.

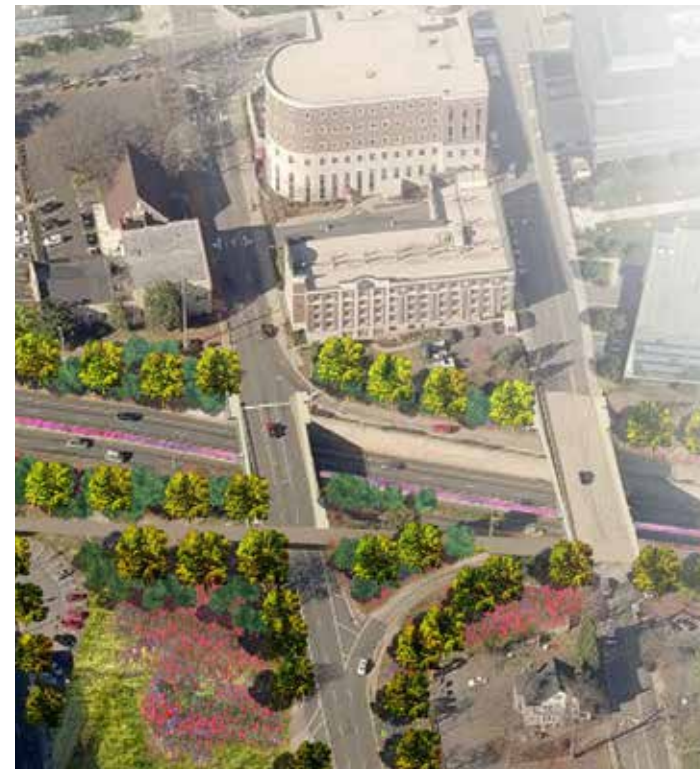

The backbone of the **Parkway Landscape** is masses of flowering understory tree, colorful landscaped medians and street trees that pull the driver up from the highway along the exit ramps to the City above.



Statuesque canopy trees signal entrance and exit ramps within the **Threshold Landscape** zones along the highway and frame the Gateways.

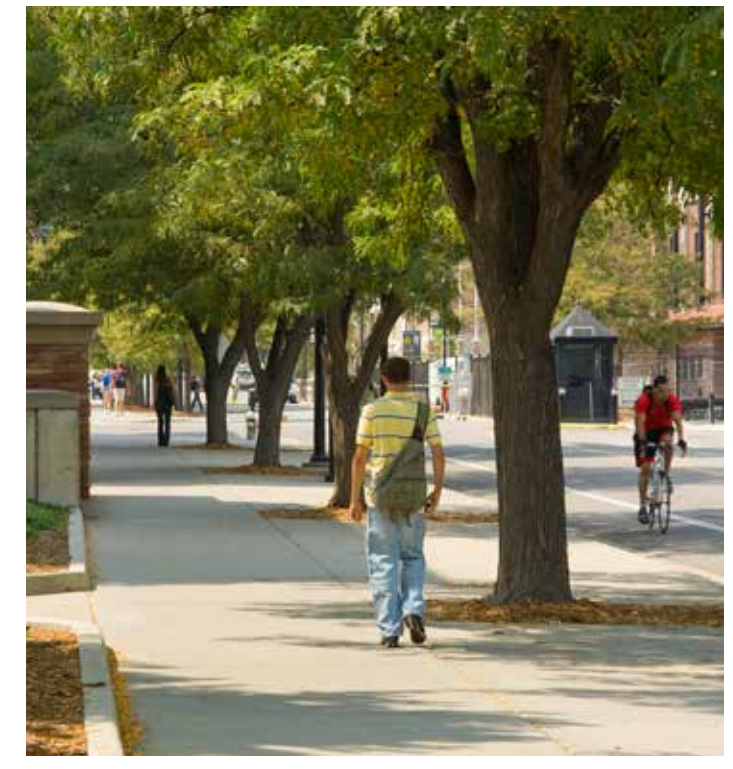

Enhance multi-modal connectivity by including adequate sidewalks and bike lanes with street trees that frame the pedestrian environment.





# BUSINESS 40 ILLUSTRATIVE PLAN

Master Plan illustratives are conceptual and do not intend to suggest specific engineering solutions or demolitions.

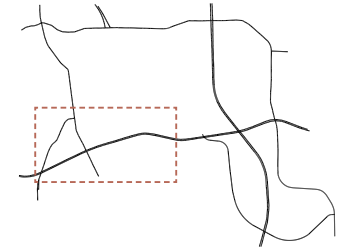



# BUSINESS 40 ILLUSTRATIVE PLAN

Master Plan illustratives are conceptual and do not intend to suggest specific engineering solutions or demolitions.

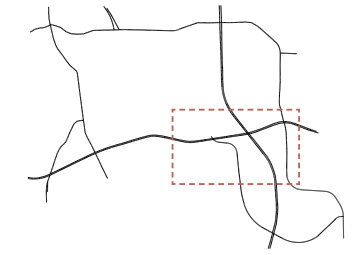



# US 52 AND SALEM CREEK CONNECTOR ILLUSTRATIVE PLAN

Master Plan illustratives are conceptual and do not intend to suggest specific engineering solutions or demolitions.

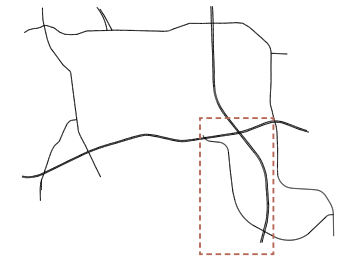



# US 52 MARTIN LUTHER KING JR. DRIVE ILLUSTRATIVE PLAN

Master Plan illustratives are conceptual and do not intend to suggest specific engineering solutions or demolitions.

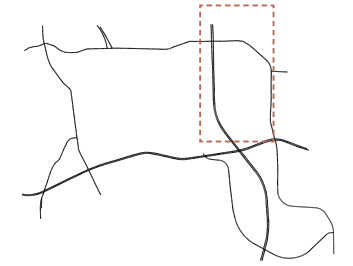



# MARTIN LUTHER KING JR. DRIVE - EAST WINSTON ILLUSTRATIVE PLAN

Master Plan illustratives are conceptual and do not intend to suggest specific engineering solutions or demolitions.

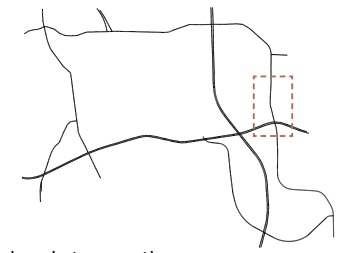



# MARTIN LUTHER KING JR. DRIVE - EAST WINSTON ILLUSTRATIVE PLAN

Master Plan illustratives are conceptual and do not intend to suggest specific engineering solutions or demolitions.

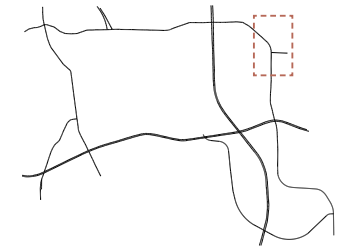



# MARTIN LUTHER KING JR. DRIVE EXTENSION AND BROAD STREET ILLUSTRATIVE PLAN

Master Plan illustratives are conceptual and do not intend to suggest specific engineering solutions or demolitions.

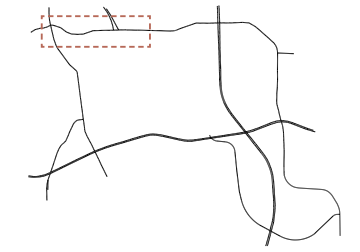



# MARTIN LUTHER KING JR. DRIVE EXTENSION AND BROAD STREET ILLUSTRATIVE PLAN

Master Plan illustratives are conceptual and do not intend to suggest specific engineering solutions or demolitions.

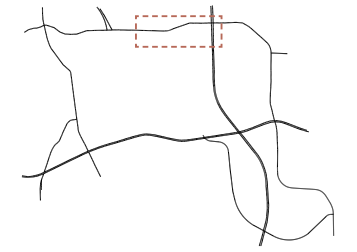



# PETER'S CREEK PARKWAY AND BROAD STREET ILLUSTRATIVE PLAN

Master Plan illustratives are conceptual and do not intend to suggest specific engineering solutions or demolitions.

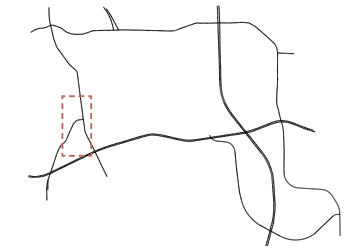



# MARTIN LUTHER KING JR. DRIVE EXTENSION AND BROAD STREET ILLUSTRATIVE PLAN

Master Plan illustratives are conceptual and do not intend to suggest specific engineering solutions or demolitions.

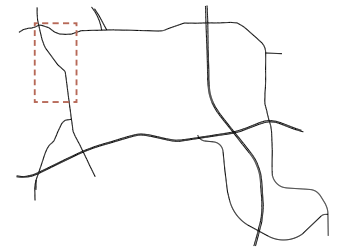





 Green



 Artful



 Iconic



 Network



# 4

## DESIGN GUIDELINES

The purpose of these Design Guidelines is to establish the acceptable aesthetic design vocabulary for the various elements that make up the Corridors. As the design process proceeds beyond the master-plan stage, and after the final transportation plan and NCDOT design requirements are finalized, these Guidelines will continue to provide aesthetic direction and will help narrow the set of choices for subsequent design efforts.

Please note: these Guidelines do not attempt to resolve all of the many technical design issues or financial decisions that will be part of the design process for each phase.

The designs shall achieve an overall composition in which each element works in harmony with every other part so that the Corridors illustrate the highest level of craft, architecture, engineering, art and sustainability. Design integration will be considered when selecting materials, considering design form and establishing budgets.

It is essential that the design team reads the Visionary Master Plan and Design Guidelines carefully prior to initiating design. It also is imperative that an integrated team of engineers, designers (architects, landscape architects, lighting designers, etc.) and artists are brought together to conceptualize and detail the design(s). This team shall be mobilized to work together collaboratively throughout the entire process so that value engineering and plan adjustments are made in concert.



# GENERAL GUIDELINES

The Creative Corridors Coalition's Design Steering Committee has determined the following visual prerequisites be followed for every section and element within the Corridors.

## General Design Guidelines

The creation of a Green Artful Iconic Network shall be the overriding design goal. All elements and features of transportation improvements shall be designed with attention to aesthetics, environmental impact, distinctive visual effect and community connectivity.

**Green Design** honors the community's commitment to improving the natural environment through skillful attention to current green/sustainable best practices and emerging technologies.

**Artful Design** demands a well-conceived and innovative approach to overall design elements and their function by creating opportunities for artistic expression – from large to small, bridges to lights and retaining walls to seating – with participation of artists throughout the process.

**Iconic Design** provides opportunities for distinctive and memorable structures throughout the Creative Corridors area.

**Network Design** includes involvement of different segments of the community in the design process as well as the aesthetic functions of bridges, roads and pathways, and multi-modal transportation.

## Green Design

Emerging and/or sustainable technologies (i.e., "green walls," rainwater capture water features, recycled and regional materials, wind power, etc.) shall be used in creative, innovative ways on major design elements including bridges, roadways, guardrails, signage and lighting fixtures (i.e., lighting that creates drama at night and, if possible, powered by alternative energy sources) thereby representing the community's commitment to sustainability and functionality. Native plant materials shall also be required in all landscape areas.

To reduce environmental impact and to promote environmental sustainability, the implementation of every design decision shall be carefully considered. This includes:

- The location from which materials come and their methods of extraction, processing and manufacturing.
- The amount and nature of long-term maintenance required so that it is economical and non-polluting.

- The method used to dispose of demolished materials so as to maintain air and water quality during construction.
- The use of recycled materials and making demolished materials available for recycling.
- The use of native, low-water-use and low-maintenance landscape materials.
- The amount of energy and water being used and the integration of on-site renewable energy concepts and water harvesting techniques.
- The impact of the design on the surrounding environment through noise, heat, pollutants and water run-off.
- Execution of the design with an integrated design team.

Please note: While there is no LEED® category for this project, it is recommended that the design team include at least one participant who is LEED®-accredited and intimately familiar with the requirements and standards of LEED® NC and other LEED® programs. Additionally, It is required that the design team become familiar with the most current GreenRoads Manual and that the design achieve at least Silver certification of that environmental rating system for roadways. The manual can be found at <http://www.greenroads.org>. Green Roads is still a new program as of 2011 and it is assumed it will evolve and gain more stature in the industry.

## Artful Design

Every new structure and object placed within Creative Corridors will provide an opportunity for imaginative aesthetic design. All new structures and objects shall be designed as part of an overall composition which defines an innovative, cohesive system for the urban environment through which we move. Artful Design shall be achieved through inclusion of artists on all design teams. Artful Design shall be applied to the function of all structures, built environments and landscapes. Artful Design shall also include temporary art objects added to existing sites.

- Designs shall be based on a well-conceived hierarchy of innovative, creative, artistic elements: bridges, pedestrian crossings, retaining walls, landscapes, signage, railings, medians, light fixtures, etc.
- Designs shall incorporate Design Guidelines recommended forms (shapes, scale, spaces, textures, etc.) without resorting to historical mimicry.
- Designs shall include continuity of accent color for structures and materials to help establish the visual threads that tie the overall composition together.

## Iconic Design

When creative individuals and teams (artists, designers, architects) are part of the design team from the beginning, they can help influence the integration of an artful expression in each design element or component. Both particular and overall visual effects shall be aimed at providing a distinctive and exciting experience for everyone, showcasing our community's history and future as a place of arts and innovation in sites such as:

- Bridges, Overpasses, Medians, Paving and Walls — The artful expression of each structure, element or form is incorporated into the areas of pedestrian use and vehicular approach.
- Lighting and Lighting Fixtures — The creative lighting of the Corridors at night shall include the bridges (both above and beneath), center medians, road lighting fixtures, green areas and other elements.
- Landscape— Both free-standing and functional works such a sculptures, benches, walkways, paths, rainwater collection/water retention, gardens, etc. are included.

## Network Design

Every network design decision shall respond to and celebrate the communities bordering the Corridors. This effort requires:

- Creating a unified design that brings the City together,
- Engaging the community in the design process,
- Choosing artistic expressions that relate to the variety of cultures and histories of the communities bordering the Corridors,
- Activating the community to participate in the implementation of the work as opportunities arise,
- Celebrating and enhancing the connections between communities.

Multi-modal systems (public transit corridors/stops, bike/pedestrian paths and greenways) shall be emphasized in the Corridors to promote connectivity of streets and land uses that assure a safe, comfortable and attractive pedestrian environment with convenient interconnections to transit. Multi-modal systems shall be integrated into the designs of bridges and vehicular rights-of-way in creative, proactive ways to stimulate the development of new connections within the community.



# GENERAL GUIDELINES

## Additional Design Standards

In addition to the basic design principles established above, the Creative Corridors shall be designed and constructed with specific aesthetic features and materials including:

- **Enhanced Bridges** shall be designed/engineered with masonry bridge abutments and center pier. The structural span shall be of either steel or concrete with an arched shape at the beam bearing. Art integration into the bridge designs shall include: 1) innovative, creative lighting elements along the bridge and pedestrian /bike areas as part of initial design development and 2) areas reserved for later incorporation of either temporary or permanent public art at bridge entrance sidewalks.
- **Focal Bridges** shall be designed/engineered with bold, dramatic, artistic structural elements that express our aspirations for the future, are distinct to Winston-Salem and integrate an arch form. They shall also use all of the same basic materials and design features required for the enhanced bridges, medians and adjoining walls.
- **Signature Bridges** shall be designed/engineered with bold, dramatic, artistic structural elements that express our aspirations for the future, are distinct to Winston-Salem and integrate an arch form. They shall also use all of the same basic materials and design features required for the enhanced bridges, medians and adjoining walls.
- **Expressway Medians** shall be designed to incorporate imaginative, colorful elements (landscape material or linear artistic creation) as the unifying element for all corridors and they shall be constructed with the goal of minimal maintenance.
- **Green Color** (shade, brightness and hue to be determined) shall be the principal accent color on painted elements (railings, bridge beams, light poles, signature/focal bridge structures, artistic median element, etc.), with final color to be one that works best with our natural light and complements red brick and native landscape materials.
- **Watersheds/Natural Areas/Parks** shall be designed/engineered as linear “green” linkages, thereby connecting the highway/street corridors and larger intersections to other parts of the Center City. Included in those landscaped elements shall be both active and passive places for community use. Those special areas shall offer multiple experiences from quiet, reflective moments (introspective, spiritual, etc.) to engaged, vibrant, loud, fun opportunities (roller-blading, skateboarding, etc.). They shall also, where feasible, include regional storm water systems that consolidate individual new project requirements and thereby minimize additional urban land use for project - specific storm-water features. Included in that water system component shall be the opening to daylight-hidden watershed tributaries.
- **Walls** (at all bridge abutments, center piers and adjoining retaining walls) shall incorporate as the principal veneer material traditional red brick masonry, thereby celebrating the community’s past and providing opportunities for various complementary trim or accent materials including (limestone, stone, accent brick, wood timbers, etc.) and brick relief in creative, innovative, artistic ways.



# BRIDGES

As one travels around the country, one can easily notice that most of our newer bridges are designed and constructed for efficiency's sake, with less attention paid to aesthetics and craftsmanship. The designs of the bridges within the Creative Corridors need to promote high design and craftsmanship, while also meeting requirements of structure and safety.

## Overall Design Intent

The commitment to execution is of primary importance if the Corridors are to be considered artful and of good design. At minimum, the bridges that make up the Corridor shall:

- Be of high craftsmanship so that surfaces meet each other seamlessly and so that there are no extraneous, cluttered, ill-conceived or distracting elements.
- Promote a unified form, appearance, scale, quality, level of detail and materiality so that the bridges read as an entire composition within the Corridor.
- Be designed with the highest consideration for aesthetic design principles such as form, balance, order, scale, unity, simplicity, rhythm, etc.
- Be designed with an integrated design team that works together throughout the life of the project to ensure the aesthetic presentation of the bridges is a priority.
- Be of the same or similar high quality material composition that meets quality expectations, while also meeting funding expectations.
- Repeat the arch form, both overhead and as part of the beam's expression.
- Integrate art, whether in the structural presentation or in adornments.
- Enable safe and attractive connections across Corridors by including nicely designed and clearly marked sidewalks, crosswalks and bike lanes.

The appearance of the bridges will be greatly improved if attention is paid to the expression of structural elegance and horizontality. This includes consideration for the railing, deck fascia, deck overhang and fascia girder. Each component of the bridge shall be in scale, proportion and balance to each other. As much as possible within the structural requirements of the design, the design shall seek to reduce the girder, deck and rail heights to create an overall feeling

of slenderness and lightness. The design shall cleanly emphasize the superstructure by providing a seamless link between all of the structural elements: from abutment to center pier to abutment and from the ground to the top of railing.

## Design Considerations (typical to all bridges)

The bridges will be seen as a collection and in sequence as the traveler moves underneath or over them. They will be viewed by faster cars on the highway and slower moving cars and pedestrians when traveling across them. A high level of design, craftsmanship, continuity of appearance (form, proportion, materials, colors, etc.) and a consistent aesthetic theme are important to maintain for all of the bridges. Their design shall have a calming influence on the Corridor, since they are in environments that already have a lot of visual clutter and confusion. They shall provide a memorable image for the City.

## Material Use Considerations

All exposed surfaces of the bridge (which include the beam, the abutment walls, the center pier wall, the center and end pilasters as well as the retaining walls that tie into the abutment walls) have to be considered together.

The primary preferred choice of materials is Applied Masonry. The bridge's wall components shall be red brick that matches the historical brick used and manufactured in the City. This material choice shall also extend to the retaining walls.

In no case shall form liners try to mimic actual masonry. It can, however, mimic the essential character of masonry construction such as horizontality, scale and texture. The use of masonry inlays may be allowed, pending review and approval of how the vertical inlay panels are detailed and how they are integrated into the vertical wall surfaces. If the use of something other than applied masonry is proposed, detail regarding the installation is required so that the visual impact of the vertical seams is reduced and/or integrated into the composition.

## Beam

**Description/Intent:** Design considerations include the depth of the beam and its proportional relationship with the deck and rail system; the relationship between the beams on a multi-span bridge; and the presentation of the fascia and underside of the bridge so that the beams are hidden and a smooth surface is presented to the driver under the bridge.

**Shape and Form:** Boxed beams allow for a smooth and consistent soffit and fascia (material, finish and form) along with the opportunity to conceal the beams and hide any utilities, creating a clean appearance. Every effort shall be made to design the bridges with enclosed boxed beams or, at minimum, a smooth underside (soffit).

Should steel beams or pre-stressed concrete beams be required due to cost or engineering issues, the design shall provide that the beams be hidden behind precast panels that will form a soffit and fascia to the bridge beams or paint them to match the required color.

The beam system in a multi-span structure shall be level on either side of the center pier support system to promote a smooth and clean appearance.

The beam shall be proportional to the deck and guardrail system so that the overall façade appearance is in balance, keeping the beam from overwhelming the deck and railing system and promoting an overall lightness and thinness.

**Finish and Materials:** The beams shall read as one expression. The face of the beam and the underside of the beam shall be of the same quality, finish, color and material.

In order to express detail and a sense of quality to the bridge structure, stained concrete is preferred for the exterior surfaces of the beam consistent with color chosen for the deck concrete. Should steel be required, they shall be consistently painted to match the required colors. See color swatches for concrete and steel colors for beams.

## Abutment Walls

**Description/Intent:** A deep abutment wall shall be provided on each side of the bridge to provide a clean vertical-wall surface while also providing a clear sense of the bridge's beginning and end. The abutment wall shall reinforce the vertical plane of the center pier. Mask walls (curtain walls) shall be used on all abutments to hide the bearing assemblies. They shall extend vertically to the height of the top of the bridge deck.

**Placement:** The abutment walls shall be located consistently from the roadway surface on all the bridges – ideally between 4 feet and 6 feet – to allow for plantings and to create more horizontality. Abutment wing walls shall extend back perpendicular to the face of the abutment wall. They shall be located so that they extend into the grade that they are retaining.

**Materials:** The materials for the abutments and abutment walls shall be the same red clay brick that is manufactured locally and chosen for the project.

## Center Pier Wall

**Description/Intent:** Many of the bridges include a center pier wall for structural support. To promote a clean and finished appearance, the center pier shall be seen as a continuous wall, rather than standard "T or "TT" center piers as are typically seen on the average bridge.

**Placement:** The pier wall shall extend the entire width of the bridge. The center pier wall shall be perpendicular to the bridge deck and not placed at an angle to the bridge deck.

**Dimensions:** The dimension shall be as required to support the bridge above.

**Materials:** The materials for the center pier walls shall be red clay brick that is manufactured locally.



# BRIDGES

## Deck/Street/Pedestrian-Level Complex

**Description/Intent:** The deck allows pedestrians, bicyclists and motorists to experience the bridge at a slower pace. Design consideration shall be given to the bridge's street and pedestrian environment so that balance is granted to both pedestrians and automobiles.

**Elements:** The deck, street and pedestrian-level complex is made of several parts, including the deck overhanging the sidewalk, the curb or barrier separating pedestrians from cars, and the travel lanes—including provision for autos and bicycles. As the diagram at right describes, separating the pedestrian from the car shall include an extruded curb barrier or a low planter that is located between the sidewalk and the street. Bike lanes shall also be provided on streets that link with the City's bicycle route plans.

**Dimensions:** The deck height will be determined by structural considerations. Its aesthetic presentation is influenced by the type of railing required and proposed. The bridge deck shall provide an overhang over the beam fascia to promote a shadow line that achieves a depth of one-third the height of the beam fascia.

**Paving Materials:** Sidewalks shall be of concrete. At each entrance of the bridge, special brick paving shall be provided across the sidewalk and street to announce it. The street shall be paved according to NCDOT requirements with colored pavers or concrete at crosswalks.

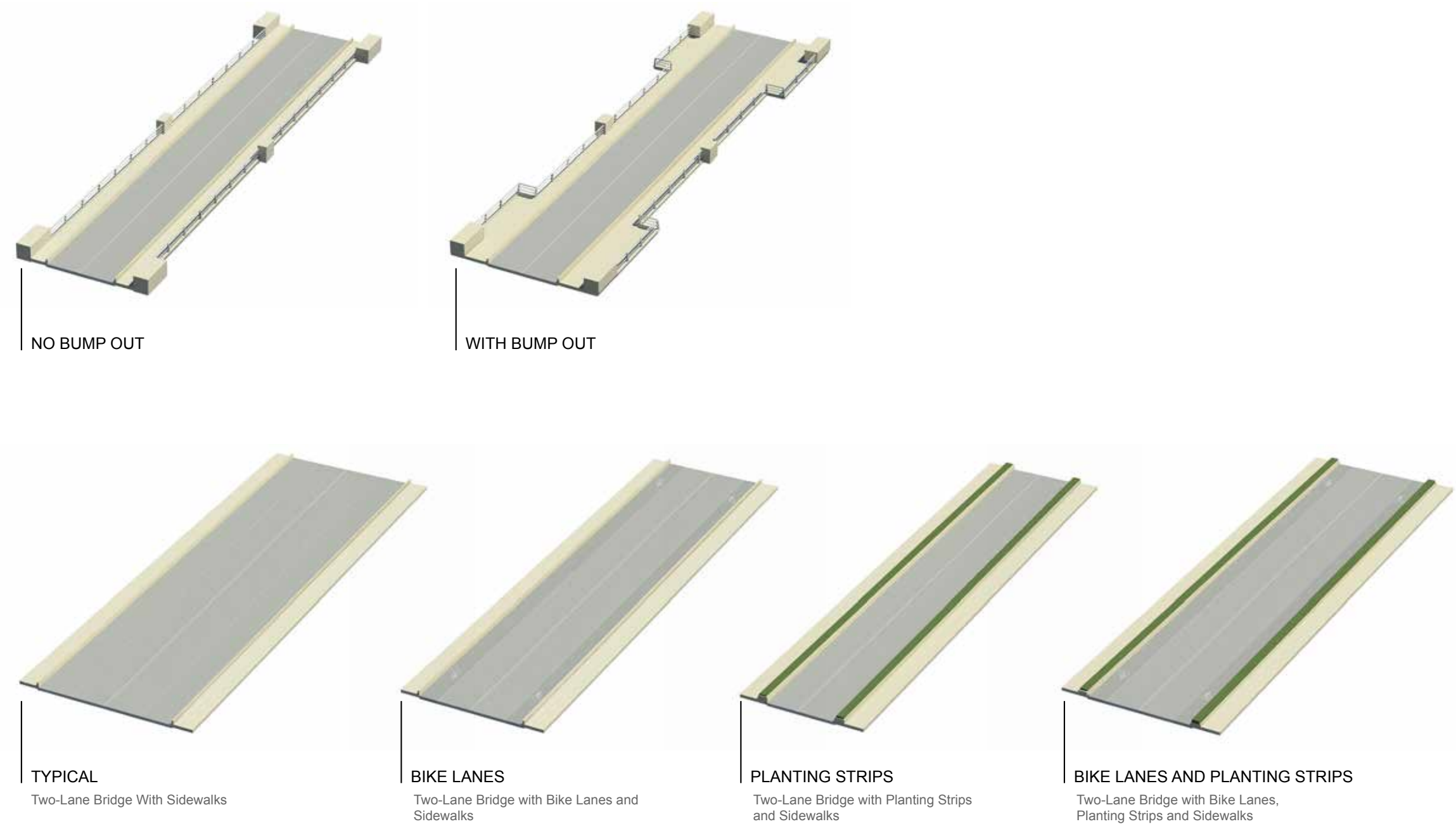



## End and Center Pilasters

**Description/Intent:** The center pilaster is important because art is applied to its surface and art projects above it. The center pilaster provides structural support as well as aesthetic value and shall be designed to support artwork on its face and on its top. This will require close coordination between the structural engineer, the electrical engineer and the artist chosen for the project. End pilasters furnish the ends of the bridge with something architectural and provide a location for the placement of art. The end pilasters shall extend to the top of the bridge railing system.

### Materials

The center and end pilasters shall be of the same red clay brick material as the rest of the bridge's walls. The artwork on its exposed face shall be of a material that allows it to appear to be part of the structure itself. Materials, textures and colors need to be complementary to the red clay brick chosen for the bridge walls.

## Railing System

**Description/Intent:** The railing system promotes horizontality and transparency and provides a place to integrate unique designs. Railings are viewed and experienced both at the crossing elevation as well as underneath by automobiles, walkers and bicyclists. The railings shall all be the same on all of the bridges, pending structural and safety requirements defined by NCDOT. A fundamental design consideration is whether the railing is required to be crash-tested – since this limits some of the flexibility in the aesthetic design. Should crash-tested railings be required, the design team shall submit for review and approval the best alternative available to meet the design intent. Should crash-tested railings not be required, the artist and designers shall create design alternatives for review and approval that meet the design objectives.

**Placement:** The railings shall butt into the bridge ends and supports so that they appear to be designed as one system. Structural supports shall be of the same material as the railing material and be perceived as a post and railing system. Should a crash-tested parapet be required, the barrier shall also intersect with the pilasters referenced

above so that they too appear to be integral systems.

**Dimensions:** Dimensions for the railing shall be determined by NCDOT in order to meet safety requirements.

**Materials:** The preferred material choice for the entire railing is for tubular steel or similar in order to express cleanliness and a contemporary aesthetic.

**Colors:** The color of steel or other metals is the preferred. Color green, shade to be determined.

## Bridge Lighting

**Description/Intent:** It is not intended that street lighting be provided on the bridges. However, there shall be provisions made for low-level pedestrian lighting, artful lighting of sculptural elements on the center and end pilaster, light that washes down the center pilaster to illuminate the pilaster artwork; and light on the soffit area that illuminates it in soft colorful light.

**Placement:** Pedestrian light fixtures shall be placed adjacent to the sidewalk on either side of the bridge in order to maintain adequate lighting for pedestrians.

- Down lighting shall be located on the center pilaster to illuminate the artwork.
- Soffit lighting shall be located within the soffit area to create a dramatic glow at night.
- The center pilaster artwork that projects above the bridge shall be illuminated either as part of the artwork's expression or with spot lighting.
- Consideration shall also be given to lighting the railings themselves in order to create drama at night and cast the railing in a colorful glow so that it expresses a horizontal line across the highway.

**Colors:** Most of the lighting shall be soft white lighting (LED) to create safety and visibility and shall meet City lighting standards. However, the soffit and rail lighting creates an opportunity for something colorful and dramatic. The artist and design team shall consider the choice of colorful lighting

on these components so that it creates an artistic, cohesive and complete presentation that will be incorporated into all of the bridges.

## Integration of Art

- The center pilaster will have a continuous artistic expression from the bottom to the top that also projects toward the sky.
- Art on top of the center pilaster shall be a vertically oriented dramatic installation that evokes expressions of innovation and what the City aspires to become. Ideally, this art will be integrally illuminated so that it is visible at night.
- Both the art that is part of the face of the center pilaster and the art that is part of the top of the center pilaster shall read as a continuous narrative with a smooth and thoughtful transition.
- Artwork should be placed on the end pilaster with descriptive panels that face the pedestrian environment.
- Art located on the top of the end pilasters, either permanent or temporary, sculptures shall be contemporary in nature and celebrate the people, neighborhoods, history and culture that make up the neighborhoods on either side of the bridge.
- The bridge railings present an opportunity to integrate artful designs that express horizontality, interesting patterns and use of materials so long as they comply with structural and safety requirements as defined by NCDOT.
- The bridges can be dramatically lit including the underside of the bridge, the railing and the sculptural elements that are part of the bridge structure.

## Integration of Environmental Sustainability

- Use regionally extracted, processed or manufactured materials per LEED®
- Use recycled content materials per LEED®
- Use low-energy lighting fixtures
- Use solar-powered light fixtures
- Dispose of construction waste properly per LEED®
- Make multi-modal accommodations
- Use high albedo (less reflecting) surfaces and porous paving materials
- Protect night sky with full cut-off fixtures
- Integrate of Community
- Celebrate crossings
- Reflect neighborhood identity in the artwork
- Create meaning for the City, its aspirations, culture, history and people
- Highlight unique designs that brand the City
- Use arch forms that are reflective of forms found in the City



# BRIDGES

## Enhanced Bridges

### Design Considerations

The Enhanced Bridges shall be designed to improve upon the standard bridge that is typically built by NCDOT. They shall be practical, repeatable and fit within NCDOT's typical design and construction methods, while also being highly crafted and aesthetically pleasing in order to create an enhanced appearance. Several additions to the typical NCDOT bridge design are advised, including abutment walls, enclosed center pier walls, center and end pilasters that support art, enhanced railings, an arched beam, enhanced railings and enhanced materiality. All of these features, combined with good craftsmanship and design, will create a strong sense of quality that is unique to Winston-Salem, especially when several are viewed together as a collection.

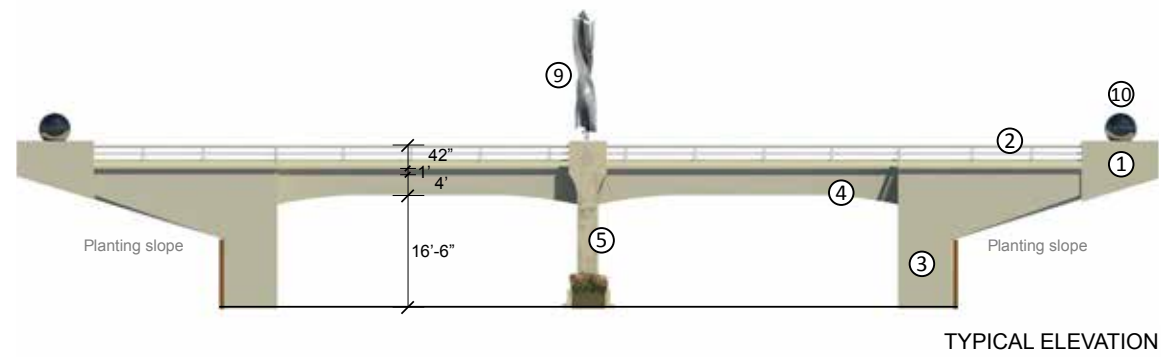

TYPICAL ELEVATION

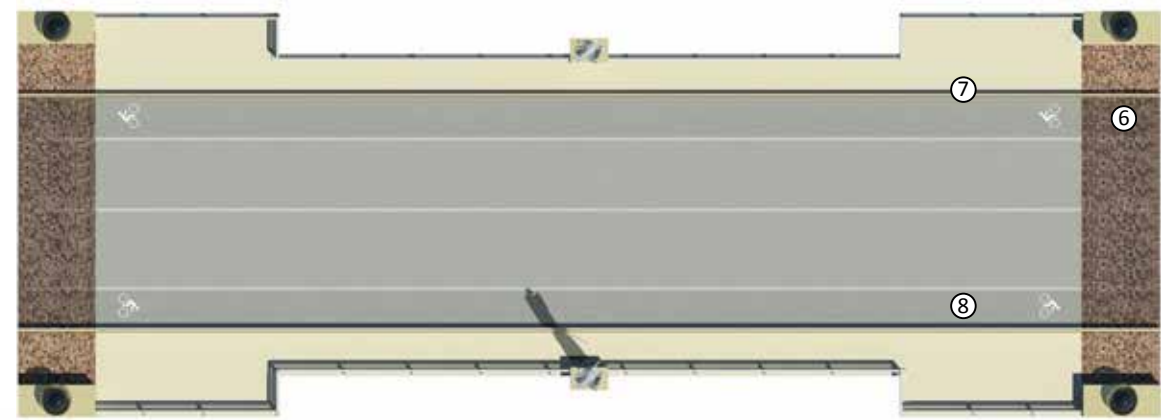

TYPICAL PLAN

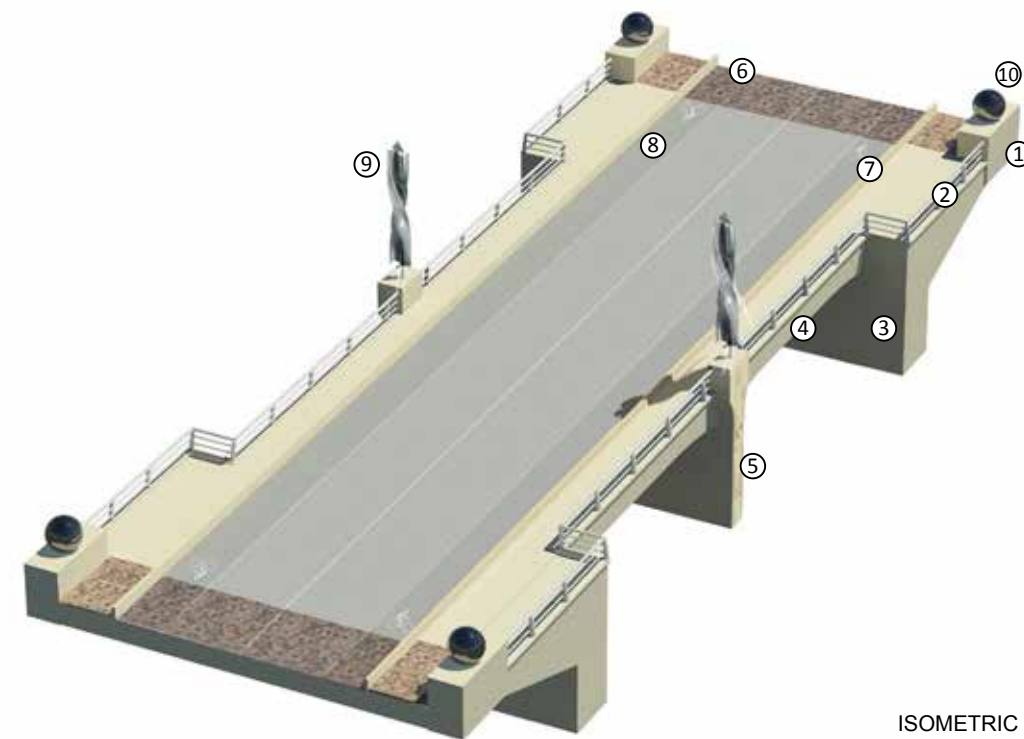

ISOMETRIC

- ① End Pilaster: Sized and designed to include public art and to express the entrance onto the bridge
- ② Enhanced Railing: Designed so that it appears integral with the end and center pilaster
- ③ Abutment Wall: Located a consistent dimension from the road shoulder, bridge to bridge
- ④ Beam (Arched): Arch geometry remains consistent from bridge to bridge
- ⑤ Center Pilaster/Center Pier Wall: Sized and designed to support art on its face and top.
- ⑥ Special Paving at Bridge Entrances: Marks passage and calms the auto
- ⑦ Planter/Pedestrian Barrier Curb: Creates an attractive and safe walking environment
- ⑧ Street/Sidewalk/Bike Lane: Matches NCDOT street dimension requirements
- ⑨ Artwork above Center Pilaster (Enhanced Bridge #2): Represents future and innovation
- ⑩ Artwork above End Pilaster (Enhanced Bridge #2): Showcases permanent or rotating sculptural exhibits



# BRIDGES

## Focal Bridges

### Design Considerations

The Focal Bridges are located at the north, south, east and west entrances to the City off of Business 40 and US 52 and give motorists the visual clue that they have arrived in Winston-Salem. The Focal Bridges build upon the design language started with the Enhanced Bridges and include an artful arched canopy above the bridge. This artful canopy frames views, announces the entry into the City with an arched form and provides shade for the pedestrian.

The arched canopy can be made part of the structure of the bridge, but it is not necessary so long as it appears integral to the structure and is elegantly integrated into the design. The canopy shall be designed with an artist so that it becomes something of value and meaning and so that it relates to the themes chosen for the project. The canopy shall be made out of a material such as aluminum that will hold up in all elements and shall be themed, designed, scaled and colored to coexist with the rest of the bridge elegantly.

The arched canopy shall be nicely lit at night with white-colored light. Every effort shall be made to reduce the amount of light needed to effectively illuminate the arched canopy so that it provides a beautiful impression at night while also respecting night-sky issues.

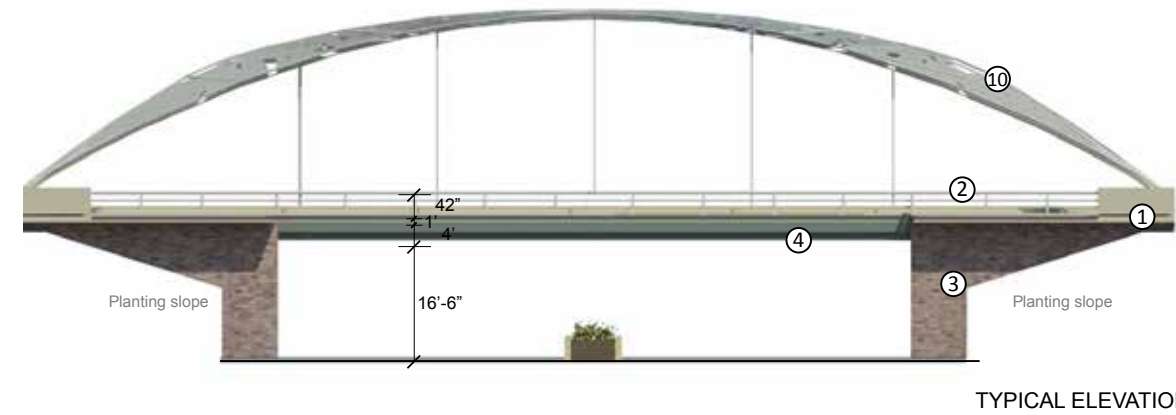

TYPICAL ELEVATION

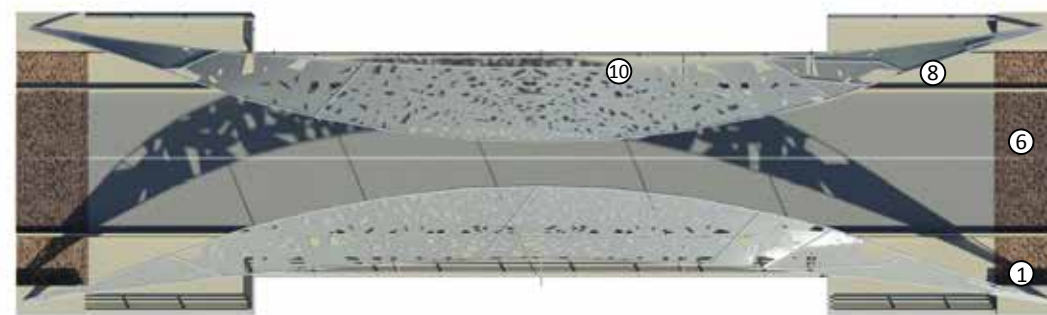

TYPICAL PLAN

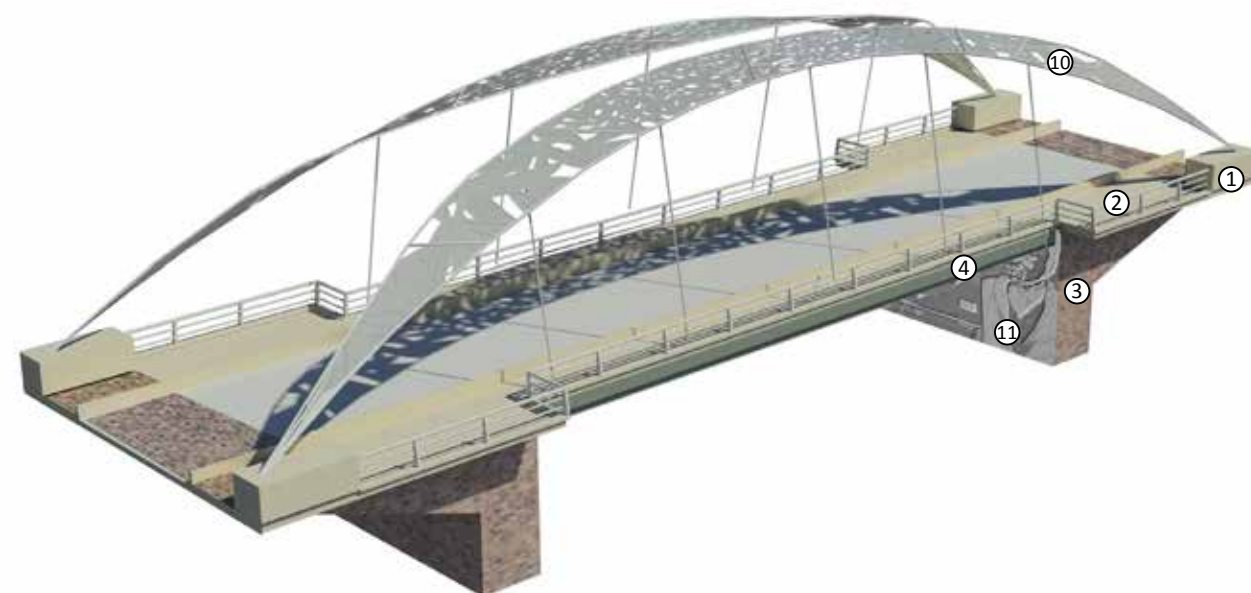

PERSPECTIVE VIEW

- ① End Pilaster: Dimensioned same as Enhanced Bridge
- ② Enhanced Railing: Designed to be the same as the one chosen for Enhanced Bridge
- ③ Abutment Wall: Located same dimension from the roadway shoulder as Enhanced Bridge
- ④ Beam (Flat): Made of the same material and color as Enhanced Bridge
- ⑤ Center Pilaster/Center Pier Wall : Not suggested for this bridge type if structurally required follow dimensions on Enhanced Bridge
- ⑥ Special Paving (Focal Bridge #1): Uses the same paving choice as Enhanced Bridge
- ⑦ Planter/Pedestrian Barrier Curb (Focal Bridge #1): Creates same environment as Enhanced Bridge
- ⑧ Street/Sidewalk/Bike Lane: Matches street dimensions determined by NCDOT
- ⑨ Artwork above End Pilaster: (N/A)
- ⑩ Arched Canopy: Shields pedestrian and frame views and supports some structural load.
- ⑪ Abutment Wall Artwork (Focal Bridge #2): Narrates story relevant to neighborhood

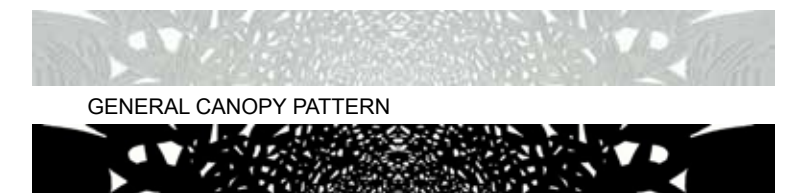

GENERAL CANOPY PATTERN



# BRIDGES

## Signature Bridges

The highest level of bridge is the Signature Bridge, which is reserved for two very important places in the City: the Liberty Street Bridge, where Salem meets Winston and the Old Salem Strollway passes underneath, and the Fourth Street Bridge, which celebrates the crossing from East Winston into the Center of Downtown. These Bridges shall be designed so that they create a powerful image for the City.

### Design Considerations

They shall have a high level of integration between art, design and structural engineering. They shall embody the characteristics that create place association, branding and image. They shall become symbols for the City and celebrate vital connections between the districts separated by the Corridors.

Because of the importance of these two bridges, the design team shall strongly consider the inclusion of a bridge architect who has experience in creating monumental bridge structures.

The design intent of these two bridges is to create overhead arches that carry some or the entire structural load of the bridge such that: the arches create a dramatic vertical expression, the depth of the beam and need for pier walls is reduced, and the environment underneath the bridge is clean and uncluttered and creates usable space – especially in the case of the Liberty Street Bridge.

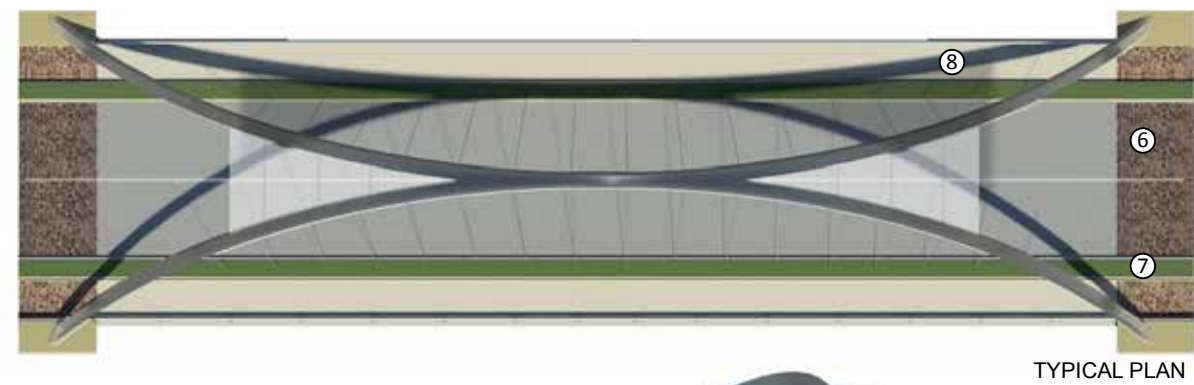
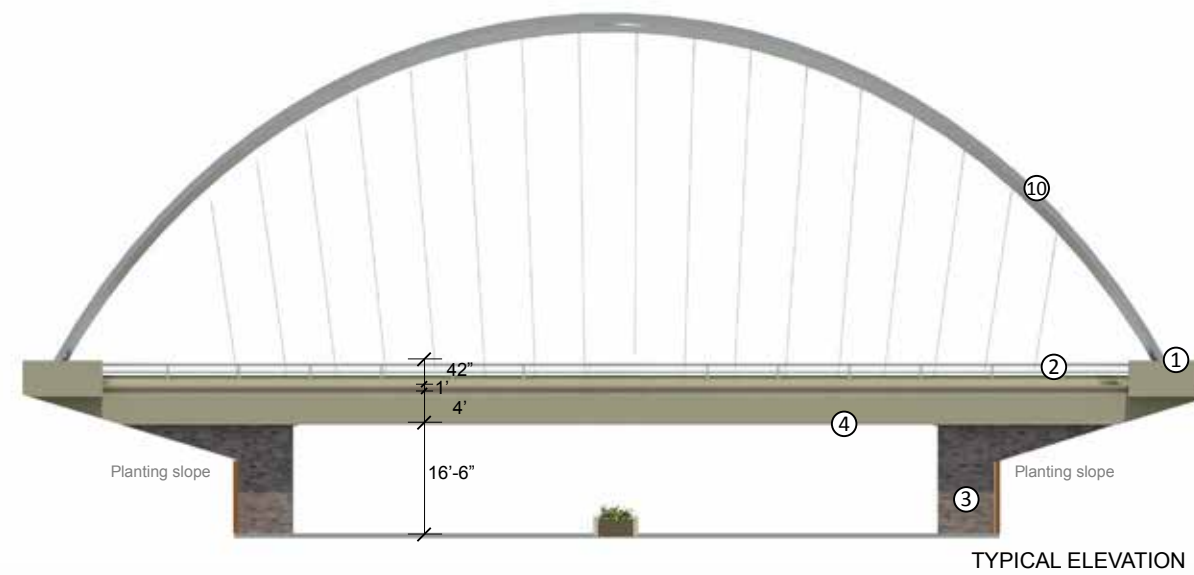

- ① End Pilaster (Fourth Street only): Is not as pronounced as Enhanced Bridge
- ② Enhanced Railing: Designed to be the same as Enhanced Bridge
- ③ Abutment Wall: Located same dimension from road shoulder as Enhanced Bridge
- ④ Beam (Flat): Made of the same material and color as Enhanced Bridge
- ⑤ Center Pilaster/Center Pier Wall (N/A): Will be included only if needed since the Arch carries structural load.
- ⑥ Special Paving (Fourth street only): Uses same material and dimension as Enhanced Bridge
- ⑦ Planter/Pedestrian Barrier Curb (Fourth street only): Creates same environment as Enhanced Bridge
- ⑧ Street/Sidewalk/Bike Lane: Matches street width determined by NCDOT
- ⑨ Artwork above End Pilaster: (N/A)
- ⑩ Structural Arch: Supports bridge load artfully designed to create drama
- ⑪ Abutment Wall Artwork (Liberty Street Only): Narrates story relevant to City history.

ISOMETRIC



# BRIDGES



Illustrative example of a potential pedestrian bridge over Business 40

## Pedestrian Bridges

The Pedestrian Bridge presents the opportunity for creativity and branding. It shall be designed in collaboration between the artist and the structural engineer and be themed and executed so that it creates impact and a unique image.

## Design Considerations

There are two Pedestrian Bridge locations on the Visionary Master Plan. One is at Green Street where it crosses the Business 40 corridor, connecting to the Ballpark and in view as people enter the City from the west. The second Pedestrian Bridge crosses US 52 in the vicinity of the WSSU campus, enabling students and faculty to walk to the University. These Bridges shall be creatively imagined and shall have a unique expression. The design shall be created in collaboration with the staff of WSSU.

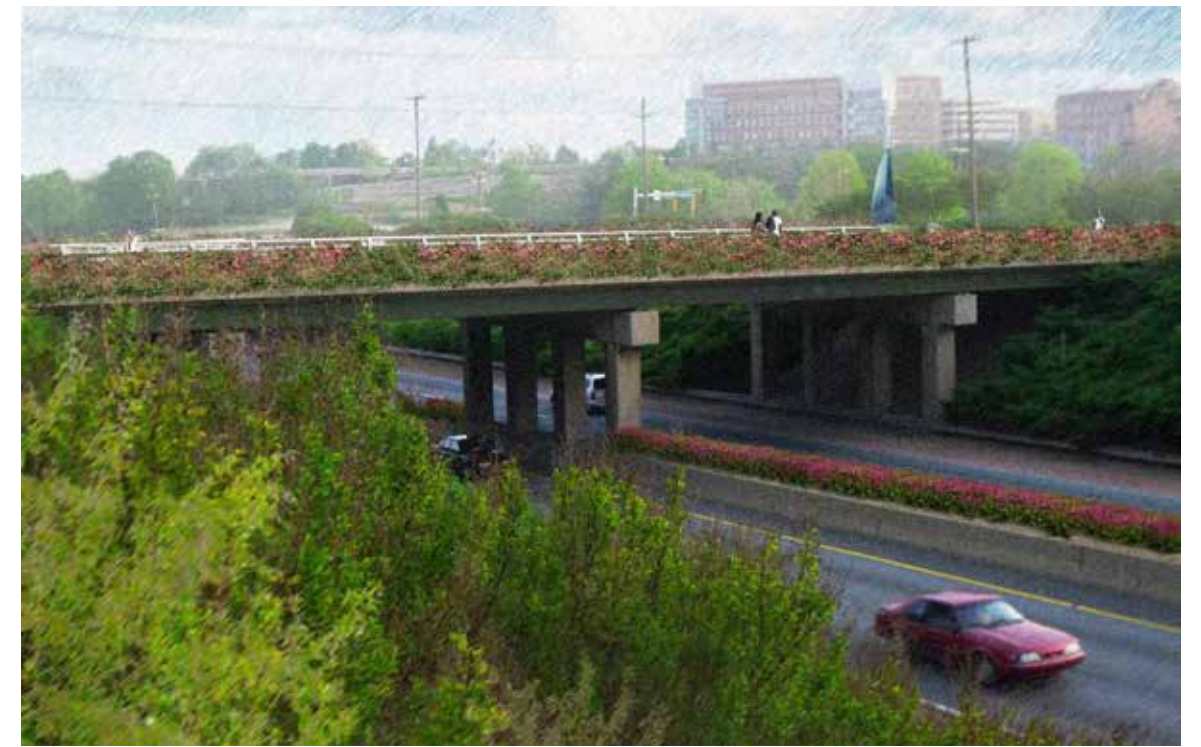

Illustrative example of a potential temporary bridge treatment for the Fourth Street Bridge over US 52

## Temporary Bridge Treatments (Fourth Street)

Not all of the Bridges that are ultimately part of the Corridor will be designed and constructed at the same time. Therefore, these Design Guidelines include treatments that can be installed in the near term should the bridge warrant treatment.

## Design Considerations

The temporary bridge treatments include an enhanced pedestrian environment using planters similar to those shown on the Enhanced Bridges. They shall also include, assuming it is part of the overall transportation planning, reconfiguring the street and sidewalk dimensions so that the pedestrian sidewalk is at least 6' in width. In order to enhance the aesthetics, a continuous "green screen" or similar installation is mounted on the railing to enable the growth of vines across the length of the bridge on both sides. Finally, the bridge's concrete shall be stained and the bridge's metal components shall be painted to match colors chosen for the rest of the Corridor.



# PEDESTRIAN CROSSINGS

## Major and Minor Thresholds and Neighborhood Crossing

**Overall Design Intent:** One of the most important components of meeting the goals of the Master Plan is highlighting the pedestrian environment so that it is safe and attractive. The design team shall consider the design of the Crosswalks as seriously as they are considering the design of the bridges and include the entire team in the design so that the execution is of the highest standard.

## Crosswalk Paving

**Design Intent:** In order keep the pedestrian environment distinguished from the rest of the street, marking the space where pedestrians cross with visible changes in paving material or color is required. For the major and minor thresholds, the entire intersection shall be considered for special pavement or color treatments. For the neighborhood linkages, only the crosswalk needs to be considered.

**Placement:** The crosswalks shall occur as determined by the geometry of the roadway design.

**Dimensions:** The width of the crosswalk shall conform to requirements of NCDOT.

**Materials:** Choices for the crosswalk area include brick patterns, colored concrete patterns and boldly colored asphalt patterns. Ideally the patterns will be designed in collaboration with an artist, subject to safety requirements of NCDOT. In order to maintain integrity in the design, in no instance shall stamped concrete that mimics brick or stone or other masonry be allowed. Any stamping or texturing shall be an artful design.

**Colors:** Color choices will be determined based on chosen material.

### Integration of Art

- Bold striping or hash marks
- Inlays into the concrete paving
- Colors that are bold and unique.

### Integration of Environmental Sustainability

- Porous paving solutions to enhance infiltration
- Paving materials with an SRI (solar reflective index) of at least 29 (per LEED®)
- Regional material usage
- Low VOC (volatile organic compound) content materials usage
- Recycled material usage
- Proper material disposal and diversion from landfill

### Integration of Community Engagement

- Art that expresses the history and/or culture of the neighborhood
- Linkage of the intersections with the neighborhoods to create identity and sense of ownership
- Creation of a safe environment for pedestrians

## Sidewalk Zone (Arterial Roadways)

**Design Intent:** To support pedestrian connectivity, safety and comfort, the Sidewalk Zone shall set back from the street as generously as possible given the right-of-way (ROW). In addition to the basic placement of the sidewalk, art can be incorporated into the environment to enhance the pedestrian experience. The Sidewalk Zone links closely with the Traditional Streetscape Zone and review of that section is required to fully understand the design intent.

**Placement:** In the ideal condition, the sidewalk shall be placed 6-8 feet behind the back of the curb along the arterial roadways. In many cases, the ROW does not support this dimension. Therefore in the near term, as improvements are made, the purchase of additional ROW to support appropriate sidewalk placement shall be considered.

**Dimensions:** In the ideal condition, the sidewalk shall be at least 6 feet minimum along the arterial roadways.

**Materials:** Concrete is acceptable as the sidewalk material.

**Colors:** Color shall be the standard concrete color.

### Integration of Art

- Low, metal, graphic, interpretative barriers with artful narratives can be placed in the space between the curb and the sidewalk.
- Artful tiles can be inlaid into the sidewalk in highly pedestrian areas.

### Integration of Environmental Sustainability

- Porous paving solutions to enhance infiltration
- Paving materials with a solar reflective index of at least 29
- Regional materials usage
- Low VOC content materials
- Recycled materials usages
- Proper materials disposal and diversion from landfill

### Integration of Community Engagement

- Art that expresses the history and/or culture of the neighborhood
- Linkage of the intersections with the neighborhoods to create identity and sense of ownership
- Creation of a safe environment for pedestrians



# CORRIDOR WALLS AND BARRIERS

## Retaining Walls

**Design Intent:** Retaining walls can contribute to the aesthetic experience if they are designed correctly. The design team shall work together to fulfill structural requirements, resolve grading issues and create designs for the walls that have a high degree of materiality, form, scale and proportion. All retaining walls shall integrate and complement the other elements of the Corridor – such as the bridges – and shall be opportunities for good design as well as artistic expression.

There are two types of retaining walls. The primary retaining wall is used to resolve grading challenges and is located at the bottom of the slope. If any retaining wall is required, the primary retaining wall shall be considered first. The other type of retaining wall is the secondary retaining wall. This wall is located up the slope and is utilized when the grading conditions require a second wall in order to resolve the grading and to meet the standards of these Design Guidelines. Each type of wall – primary and secondary – has its own aesthetic requirement.

**Shape/Form:** All retaining walls shall be simply designed without columns interrupting their smooth horizontal flow. Additionally, the walls shall avoid sharp changes in height and provide smooth transitions from the highest point to the lowest. Finally, the walls shall be designed without overtly expressed caps; any capping shall be of the same material as the face.

**Location:** The primary retaining walls shall be located with a consistent dimension along the bottom of the slope 4-6 feet back from the face of the abutment walls. The secondary wall, if required, shall be located 12 feet back from the primary wall to allow for landscape plantings and/or the proposed multipurpose trail.

**Dimensions:** All retaining walls shall be designed to retain their intended slope. Both the primary and secondary retaining walls shall be 6 feet in height or less unless special circumstances require otherwise and shall be subject to review and approval by the reviewing agency.

- ① Primary Wall
- ② Secondary Wall

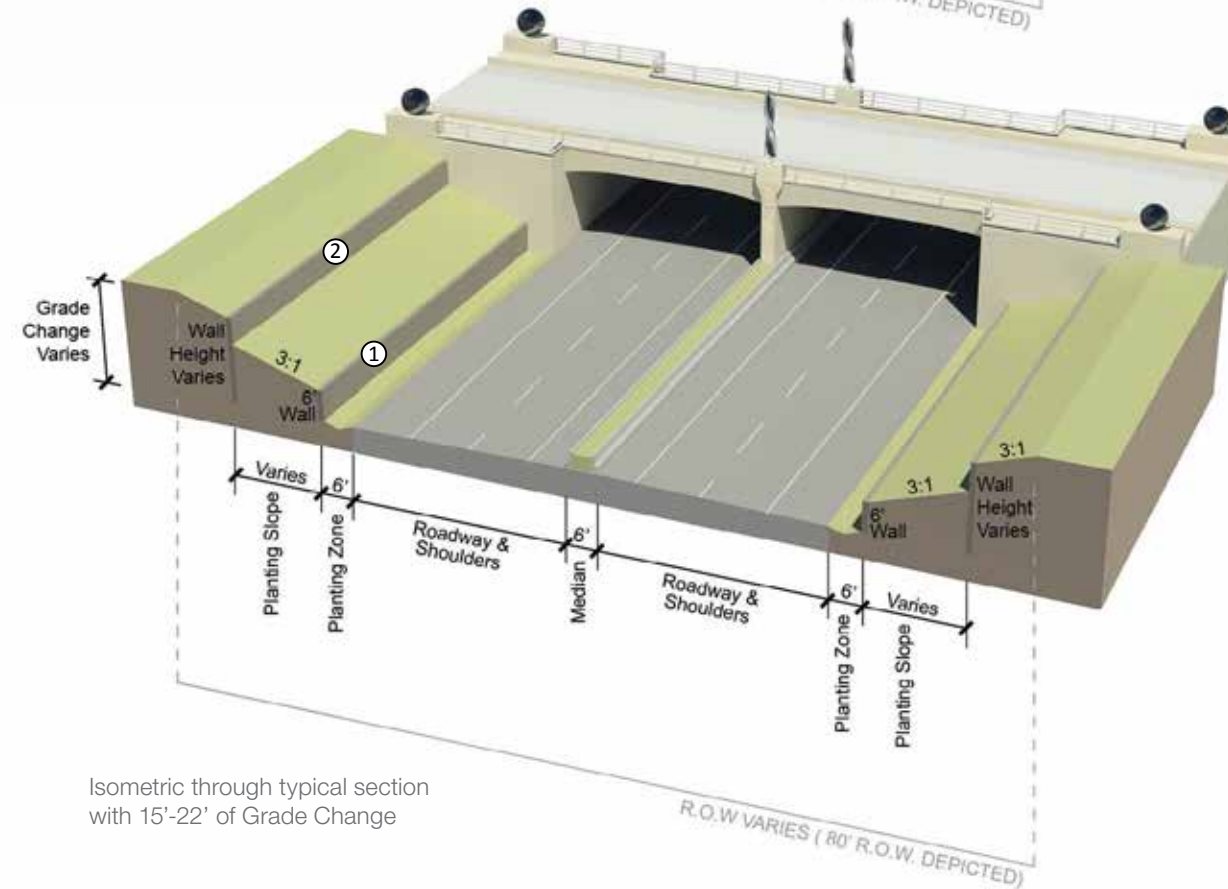
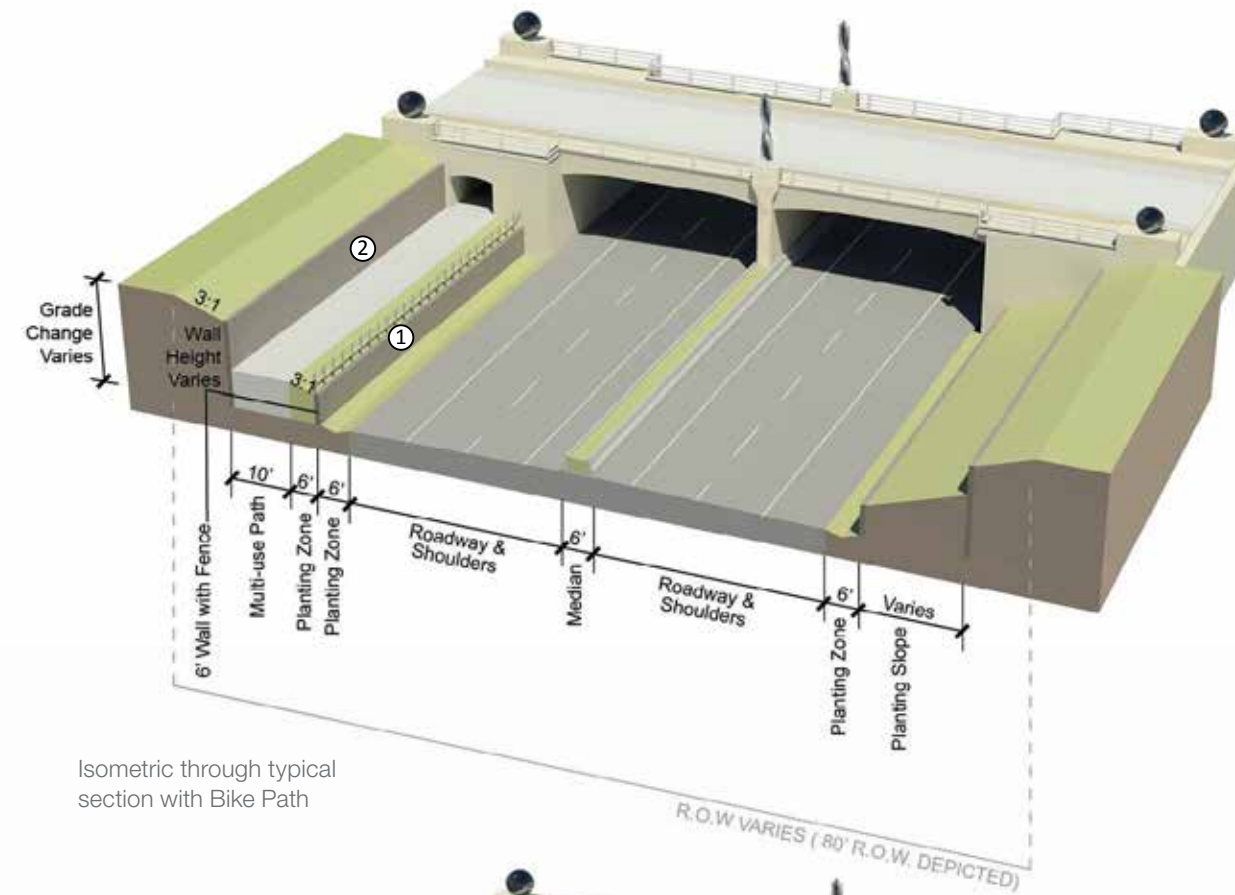



# CORRIDOR WALLS AND BARRIERS

## Retaining Walls (Continued)

**Materials:** The primary retaining wall shall be of a high quality finish and material in order to create a sense of warmth and value. The primary retaining wall shall be designed so it is faced with applied masonry joined to the concrete backing wall. As an expression of the City's history and culture, the wall shall be faced with brick, consistent with the brick used on the bridges.

Should value engineering require it, the design team may submit for approval designs for the primary retaining walls that include something other than applied masonry, such as stained or colored concrete, form liner textures or masonry pressed into tilt-up concrete panels that face the concrete backing walls. In no case will unfinished, unstained concrete be allowed.

The materials of the secondary wall shall be chosen so it blends into the natural environment. For this wall, green screen coverings, plant walls or gabion treatments that face the concrete backing wall shall be considered. Additionally, the secondary wall may also be designed so that it is of stained concrete with artistically designed textures, applied using form liners that mimic nature. In order to break down the scale of the secondary wall, the design team may elect to use a combination of the above, designed in a rhythmic pattern along sections of the wall.

### Integration of Art

- Artistic patterns in the zone where the retaining wall is in the vicinity of the bridge structures.
- Artist-designed form liners that mimic nature for the secondary walls.

### Integration of Environmental Sustainability

- Usage of materials that are regionally extracted, processed or manufactured material
- Low VOC content
- Recycled material usage
- Proper material disposal and diversion from landfill

- ① Primary Wall
- ② Naturally tie back grade at a maximum slope of 3:1

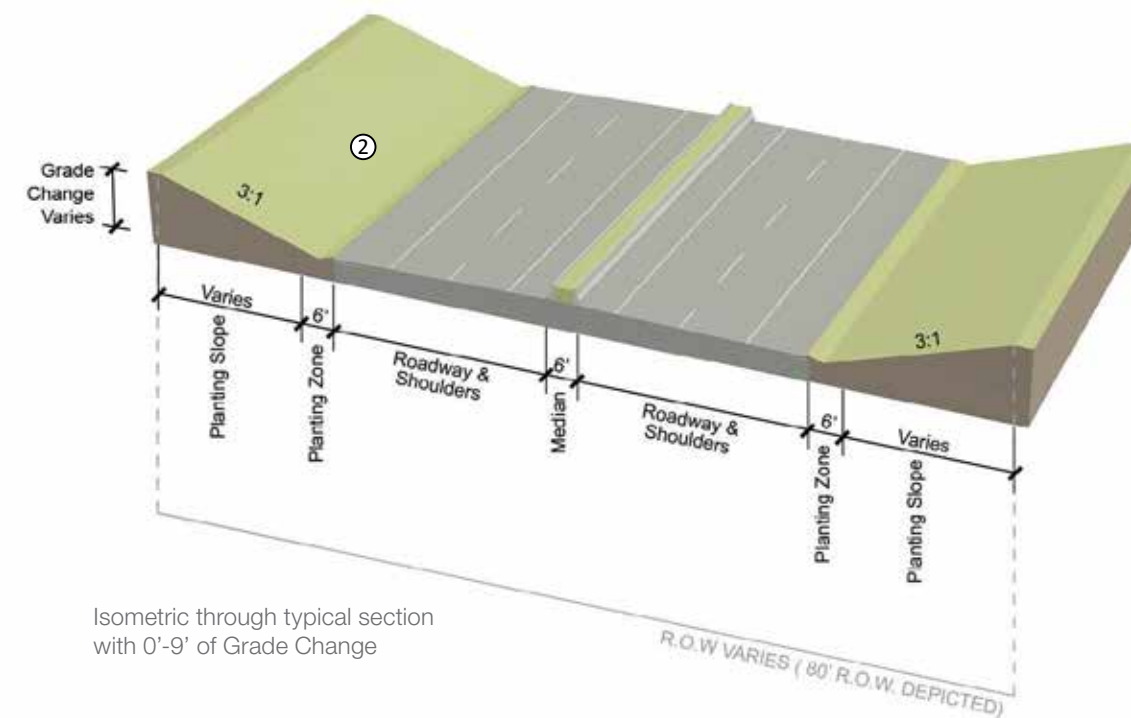
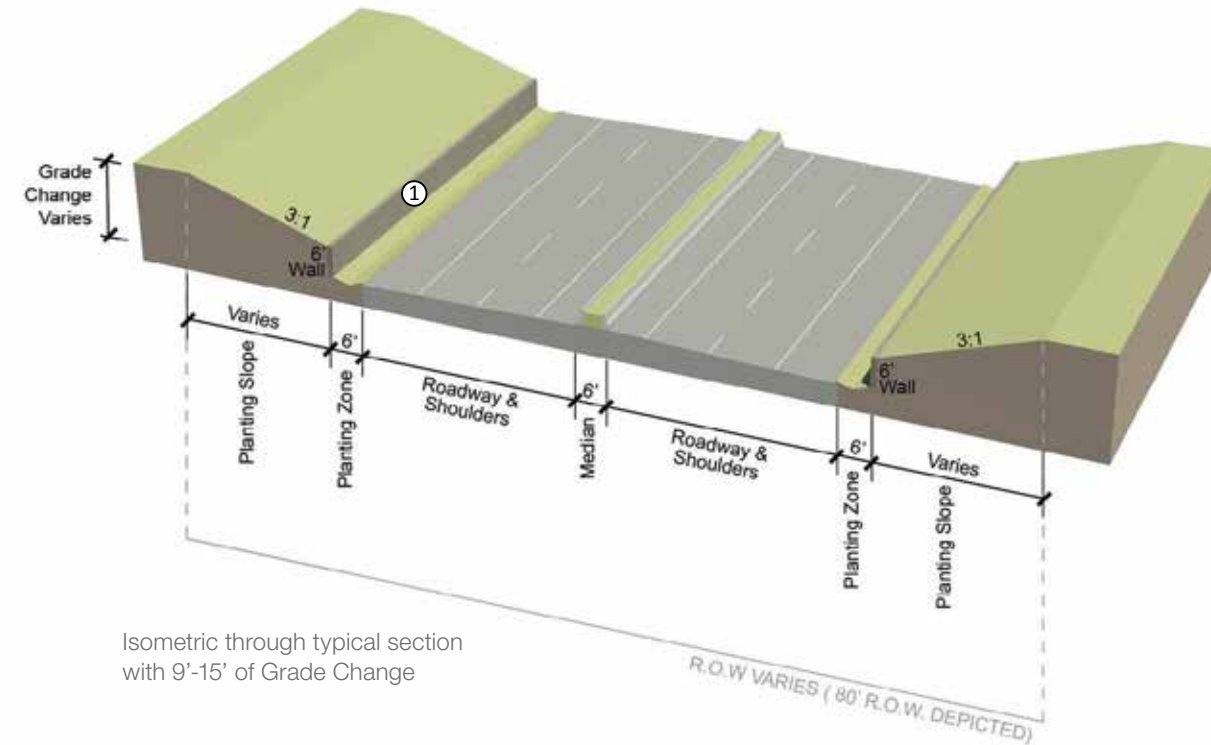



# CORRIDOR WALLS AND BARRIERS

## Center Median

**Design/Intent:** The center medians tie the Corridors together and contribute highly to the “Green Artful Iconic Network” concept. Every effort shall be given to design, plan and engineer a consistent center median that is adequate to install colorful plant materials or art installations for each part of the Corridor.

**Shape/Form:** The center median shall be planned as a continuous linear expression for each leg of the corridor. Ideally within the highway, the center median shall be sized to allow for a continuous planter that is constructed using the “short” Jersey barriers of consistent height. Should a planter not be used, a continuous colorful artistic expression, ideally using light, shall be designed.

In the case of the arterial roadways, the center median shall be designed as an extended curb of a consistent height that runs the length of the roadway and sized to allow for the planting of shrubs and understory plant materials. Should the plants not be provided – due to cost or maintenance or spatial limitations – a continuous colorful artistic expression, consistent with the highway treatment, shall be provided.

**Dimensions:** The Jersey barrier used for the center median in the highway shall be 30 inches tall maximum. The outside dimension of the planter created by the Jersey barriers shall be 6 feet to relate dimensionally with the bridge’s center pier wall. In order to provide detailing to the Jersey barrier, a scoring pattern shall be integrated into the concrete or the concrete shall be enhanced with a brick veneer.

The extruded curb of the arterial roadway center median shall be 6 inches high and 6 inches wide. The outside planter dimension shall be 4 feet minimum.

**Materials:** The Jersey barrier used for the center median planter in the highway shall be precast concrete and stained. The extruded curb in the center median planter in the arterial roadway shall be concrete stained.

### Integration of Art

- Colorful lighting designs that create a continuous linear expression of light for the entire length of the corridor.

### Integration of Environmental Sustainability

- Usage of materials that are regionally extracted, processed or manufactured
- Low VOC content
- Usage of recycled materials
- Proper material disposal and diversion from landfill

## Sound Walls

**Design/Intent:** At the time of this writing, it is not known if sound walls will be required. Given that there are many other types of walls currently required for which guidelines have been developed, should sound walls also be required, their design should be similar to the other walls so that they blend into the landscape.

**Shape/Form:** Ideally, the sound walls are designed to a consistent height that avoids abrupt changes to the top of wall elevation.

**Location:** These walls shall be located at the edge of the ROW at a dimension of 3 feet from the edge of the ROW to allow for plantings on either side.

**Dimensions:** As required to serve their function.

**Materials:** Green Screen over standard sound wall panels.

### Integration of Art

- Artistic textures and narratives integrated into the design of the walls
- Integration of Environmental Sustainability:
  - Regional material usage
  - Low VOC content materials
  - Recycled material usage
  - Proper materials disposal and diversion from landfill
- Noise pollution reduction

## Fences

**Design/Intent:** Black metal fences appear often in the Winston-Salem landscape. They can be seen on MLK Jr. Drive, on the campus of WSSU and on University Parkway. They can also be seen on older homes within the historic parts of the City. They establish a sense of place and character that is desirable within the Corridor.

**Shape/Form:** Picket Fencing with artistic customizations.

**Location:** Along the ROW line on MLK Jr. Drive to establish a character for the street and to link it aesthetically with the fencing that exists on WSSU’s campus and on University Boulevard.

**Dimensions:** The recommended height is 3 feet, which shall be a consistent elevation around the Corridor.

**Materials:** Black aluminum or similar material.

### Integration of Art

Customized fence panels and posts that create a unique expression—particularly around highly pedestrian environments.

### Integration of Environmental Sustainability

- Regional material usage
- Low VOC content materials
- Recycled material usage
- Proper material disposal and diversion from landfill



# ARTFUL MEDIANS



Sculpture in center median

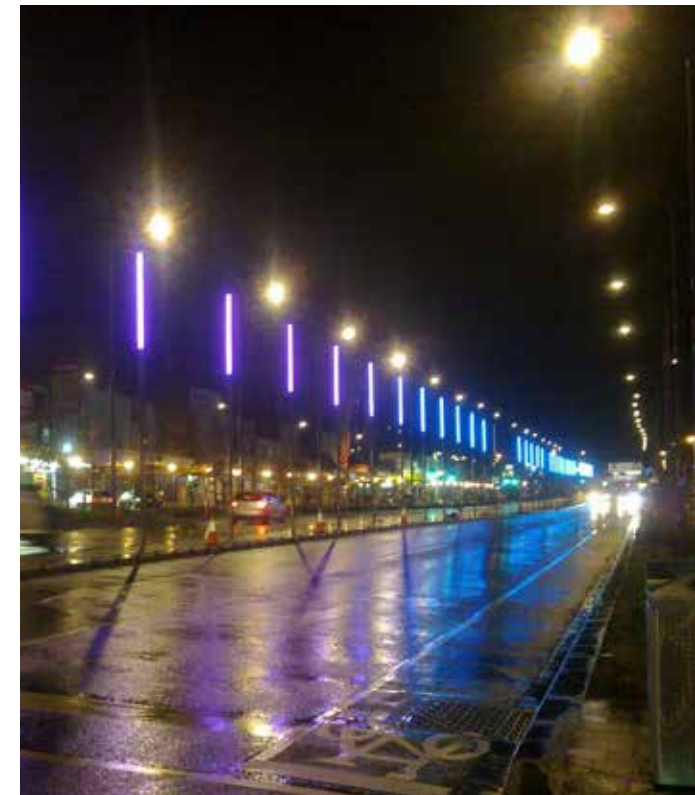

Changing lighting patterns in median



Elegant planting with seasonal color



Planting in highway median



Simple native stone paving in the median



# ARTFUL GREEN HIGHWAYS RESOURCES

At the time of the creation of this master plan in 2011, the desire for more artful and green highways is growing. This combined with the need to repair aging infrastructure as well as resistance put up by citizen groups to replace urban highways that fracture neighborhoods has resulted in the establishment of several tools and resources that are useful to consider within the design process.

## NCDOT Art Policy

NCDOT has enacted an art policy, the purpose of which is to “establish procedures for the department to evaluate and permit the placement of Public Art within its right of way.” In their view, “transportation facilities enhanced by public art elements provide aesthetic and cultural benefits to a community.” NCDOT’s first priority is to provide a safe and efficient transportation facility, but they also recognize that the way transportation corridors are designed and executed can have additional economic, environmental, aesthetic and community benefits for Winston-Salem. NCDOT’s public art policy sets forth a process for review and approval of art within its right-of-way as well as guidelines for funding and maintenance of improvements.

## The Green Highways Partnership:

The Green Highways Partnership (GHP) exists to help advance environmental stewardship in transportation planning, design, construction, operations and maintenance while balancing economic and social objectives. It offers guidance and resources to help produce green highways that go beyond mere compliance to a list of guidelines and, instead, leave the project area better than before. While not every recommendation may be applicable to the Creative Corridors project or admissible by NCDOT, these recommendations and

resources provide a great starting point from which to base the Corridors’ design.

The GHP, endorsed by the US Environmental Protection Agency (EPA), the Federal Highway Administration (FHWA) and the US Department of Transportation, has produced a number of products and publications useful in designing green highways. They include:

### GHP FACT SHEETS

- Collaborating for Success
- Stormwater Management
- Recycle and Reuse

### PLANNING & PRACTICE

- Context Sensitive Solutions
- Core Principles of CSS
- Ecological FHWA Ecosystem Approach

### STORMWATER MANAGEMENT

- LID Unified Facilities
- LID Pugetsound Lid Manual
- LID Handbook Sandiego
- Permeable Pavements SeattlePU
- Pervious Concrete ACPA
- Pervious Concrete NRMCA

### CONSERVATION & ECOSYSTEM PROTECTION

- EMS ELR NEPA
- EMS NEPA GUIDE
- EMS WHAT IS EMS

### GREEN INFRASTRUCTURE

- Green Infrastructure Funding
- Green Infrastructure Retro Fits
- MSHA Green Infrastructure Assessment
- SUSTAINABILITY & STEWARDSHIP
- Stewardship GHP MOA RM
- Sustainable PCCP SR

### HIGHWAY BEST PRACTICES

- Highway Best Practices Ranked

## RATING SYSTEMS

- Rating Systems Green Roads
- Rating Systems Green Roads Summary
- Introduction to Green Roads V1.0
- Climate Change AASHTO
- Highway Builder MAG Spring 09
- USGS Strategy

## Guidelines for Bridge Design:

The Minnesota Department of Transportation - Office of Bridge Construction created a manual titled “Aesthetic Guidelines for Bridge Design” to guide the aesthetic design of bridge structures. The publication was created in 1995, but is still relevant as it relates to aesthetic principles applied to the realities of bridge engineering.

## Exploring Green Highways

September/October 2008 Feature in ASTM Standardization News by James M. Bryce.

This paper describes the attributes of what makes for a Green Highway. According to the article, A green highway can be defined by five broad topics, which includes

- **Watershed Driven Storm Water Management**
- **Life Cycle Energy and Emissions Reduction**
- **Recycle, Reuse and Renewable Resources**
- **Conservation and Ecosystem Management**
- **Overall Societal Benefits**

For the complete article, see [http://www.astm.org/SNEWS/SO\\_2008/bryce\\_so08.html](http://www.astm.org/SNEWS/SO_2008/bryce_so08.html).

## The GreenRoads Manual

The GreenRoads Manual is an environmental rating system for roadway design and construction created by the University of Washington in collaboration with CH2MHill. It is a performance rating system similar to LEED. It includes performance requirements in categories for:

- Project Requirements
- Pavement Technologies
- Materials and Resources
- Access and Equity
- Construction Activity
- Environment and Water

Projects can achieve different levels of certification based on achieving point thresholds.

For the complete description of the program and manual see <http://www.greenroads.org>

## NCDOT Complete Streets Policy

NCDOT’s Complete Streets Policy was originated as part of The Complete Streets Act of 2009 (S.B 584 and H.R. 1443). The policy was adopted “in recognition of the significant influence that street design has on safety, environmental integrity, public health, economic vitality and community livability. “

The purpose of the policy is to “set forth the protocol for the development of transportation networks that encourage non-vehicular travel without compromising the safety, efficiency, or function of the facility.

For the complete policy, see: <http://www.nccompletestreets.org/policy.asp>

## NDOT Aesthetics Alternative Manual

Many states are creating manuals for aesthetic treatments of transportation corridors. Nevada DOT has adopted a comprehensive set of aesthetic design standards and guidelines that provide guidance to context and environmentally sensitive designs for its state highways. NDOT lists the benefits as:

- Enhancement of local and regional character through preservation of and emphasis on cultural and natural features, scenic views and community identity;
- Improvement in the visual quality of Nevada’s highways and thus the driving experience, resulting in a positive influence on Nevada’s tourist-based economy.
- Improvements in safety and wayfinding
- Provision of a predictable, yet engaging, driving experience
- Enhancement of environmental health by appropriately accounting for wildlife, erosion and runoff, and native plant communities.



# LANDSCAPE

## Landscape Zones

**General Intent:** While efforts are being made to green up our highways, the landscape that is created is generally not designed as a landscape expression. Rather, our highways are planted inconsistently, with an informal collection of trees, grass, flower beds and shrubs that many times seem unnatural in their location. The design of the Creative Corridors' landscapes is intended to promote a landscape that provides wayfinding, creates drama in key locations, orients views, responds to its environment and establishes order.

The landscape plan is organized into landscape zones that express the attributes (environment and place) of the corridor of which they are a part. The landscape zones repeat themselves around the Corridors and adapt to the changing environments that they are part of. For instance, Gateways and Thresholds are consistently expressed, with subtle variations in form and material depending upon their location. The Gateways and Thresholds are held together with consistent design ideas for traditional streetscapes and parkway plantings. To provide accent and variety, lowland areas have their own unique expression.

To allow the planting vision to be fully realized, planting areas along the sides of roads and creeks must first be cleared of any invasive species. Plants such as Kudzo must be eradicated before planting systems are installed. Without eradicating such species, the planting investment will be at serious risk. In areas that may not need additional planting, all invasive species should be removed to allow native plants to grow and to esthetically restore areas that have been blighted by plants such as Kudzo.

## Integration of Art

- Regular spacing of trees which promotes order and rhythm.
- Open areas which provide the opportunity for land art created by artful grading geometry and interesting water features.
- Seasonal color creates opportunities for composition and pattern.
- The types of plant materials chosen and the nature of how they are planted create expressions of scale and composition and geometry.

## Integration of Environmental Sustainability

- Use of native plants to reduce maintenance and to reduce water consumption.
- Creation of additional tree canopy to shade streets and reduce heat island effects.
- Usage of water harvesting and grey water irrigation techniques (where irrigation is used at all).
- Remove existing invasive species.
- Usage of water management best practices to reduce stormwater impacts.
- Plant massing usage to enhance wildlife connectivity (vertical and horizontal connectivity) around the Corridor.
- Usage of porous paving techniques

## Integration of Community Engagement

- "Plant a tree" or other community efforts in areas that lend themselves to it
- Volunteer maintenance efforts
- Community donations of plant materials





# LANDSCAPE

## Gateway Treatment

The Gateways occur at the major highway interchanges. Given that the interchanges are generally open and consistently sloped, orderly landscapes organized at a large scale can be used to create a sense of “gateway” into the City. Manipulating contours can create naturally functioning drainage areas that are artfully shaped to serve as naturally functioning water features. Finally, the earth can also be shaped into forms that provide artistic expression.

**Design Intent:** The landscape proposed in the Gateways shall be simple, yet powerful and shall signal the entrance into the City. It shall respond to the open character of the land, while also presenting a planting geometry and plant palette that matches the scale of the space.

**Plant Organization:** The planting scheme is a simple, repetitive planting of large trees and native ground cover. The primary tree pattern in the Gateway shall be large statuesque trees that are organized into a grid that is oriented toward views of the City. This grid pattern will overlay the varied topography and give the space a sense of order, scale and drama. A second pattern of canopy trees shall be located linearly to frame the gridded space and align with the access roads providing shade, rhythm and order to those streets as they pull out of the linear highway space.

Underneath the tree grid, a simple ground plane of native grasses and wildflowers shall predominate. The grass and wildflowers shall eventually transition into the artfully formed and appropriately planted natural drainage areas.

## Plant Materials

The tree species for the grid pattern shall be tall pyramidal trees of statuesque form. Trees like Pin Oak, Dawn Redwood or Magnolia Grandiflora are large pyramidal tree that have a grand character when planted out in the open. The trees that line the access road shall be Willow Oak or similar to match trees chosen for the Threshold Landscape Zones. The ground plane shall be planted in native grasses and wildflower mix.

## Water

**Irrigation:** Temporary irrigation will enable plants to adapt to their new environment.

**Water Management:** Water shall be managed into bio-retention areas that also serve as artfully designed water features in the landscape. In addition to the water that is managed within the Gateway space itself, storm water from other locations, as determined by the City’s water management plan, shall also be accommodated.

- ① Repetitive tree planting
- ② Linear tree planting on exit ramp
- ③ Native grasses and wild flowers
- ④ Graded area for bio-retention
- ⑤ Large-scale art Installation



Example of Gateway Landscape Zone on Business 40 - Depicted from Fourth Street to Broad Street



Example of Gateway Landscape Zone at the interchange between US 52 and Business 40



# LANDSCAPE

## Threshold Treatment

As mentioned previously, Threshold Zones signal the access to the City from its perimeter roadways. When one is driving along the highway or arterial roadway, the landscape shall signal the access and create an instinctive wayfinding device that reduces the need for signage as the only way to describe how the City is organized.

**Design Intent:** The Threshold Landscape Treatment couples with the Pedestrian Crossing Major and Minor Thresholds treatment (page 75) and supports the paving, sidewalk and median treatments. The intent is to provide stately shade trees placed on regular spacing that will create scale, rhythm, continuity and canopy. These trees will flank both sides of the roadways and be in alignment with each other, creating a clear geometry and spacing across the roadway. Medians continue their consistent treatment through this zone, just like they are treated along the length of the rest of the Corridor. Grass, or “rain garden,” landscapes shall be planted within the tree lawns that separate the sidewalk from the street. In urban mixed-use areas, trees will be planted in tree grates in the sidewalk.

**Plant Organization:** Formal plantings of street trees approximately 40 feet on center within tree lawns or rain gardens

### Plant Materials

**Trees:** Willow Oaks or Large Canopy Trees

**Ground cover:** Grass or plant materials suitable for rain gardens

### Water

**Irrigation:** Temporary irrigation enables plants to adapt to their environment

**Water management:** Bio retention areas (rain gardens) between the sidewalk and the curb where the water management plan allows for it.

- ① Large Canopy Trees
- ② Large massings of mixed native understory
- ③ Rain Garden zone
- ④ Graded area for bio-retention



Example of **Threshold Landscape Zone** on Business 40 - Depicted from Marshall Street to Church Street



Example of **Threshold Landscape Zone** on Martin Luther King Jr. Drive at the intersections of Third, Fourth and Fifth Streets



# LANDSCAPE

## Parkway Treatment

The length of the Corridors, between the Gateways and the Thresholds, creates opportunities to promote a landscape of linear expressions of tree and shrub masses that frame the roadway, provide seasonal color and create a pleasant and colorful driving experience.

**Design Intent:** The highway portions of the Corridors contain linear stretches running parallel to the roadway in between the Gateways and Thresholds. These portions of the Corridor shall be designed as a continuous landscape expression that ties the entire Corridor together, responds to the different topographic and roadway geometry, integrates with existing plantings that are worthy of retention, creates a continuous massing of vegetation and provides a riot of seasonal color that is extended as far as possible through the year with the use of native understory trees and large shrub materials. In order to provide accent and rhythm, massings of eastern Red Cedar slash diagonally across the highway.

**Plant Organization:** Tight massing of understory trees and shrubs at various plant spacings to create a naturalized organization and a complete massing of vegetation.

## Plant Materials

**Trees:** Colorful and seasonal native understory including Service Berry, Redbud, Dogwood and other native materials. Eastern Red Cedars planted en masse create accents.

**Ground cover:** Mulch or low native ground cover

## Water

**Irrigation:** Temporary irrigation until plant material is established

**Water management:** Bio retention (rain gardens) along the roadway shoulder where feasible

- ① Canopy trees
- ② Large massings of mixed native understory
- ③ Native grasses and wild flowers
- ④ Bio-retention area



Example of Parkway Landscape Zone on Business 40 - Depicted from Green Street to Marshall Street



Example of Parkway Landscape Zone on US 52 at Winston-Salem State University



# LANDSCAPE

## Lowland Treatment

**Locations within Corridor:** The Lowland Treatments occur in several places where the roadway is spanning over a creek, drainage or water body.

**Design Intent:** Low areas can be highlighted with landscape so that their environment is revealed and so an interesting break in the pattern of parkway landscape occurs. In some instances, the Lowland Zones are natural areas and the design response is to plant appropriate large trees that typically occupy these environments, such as Sycamore, that will grow to become visible at the roadway level. In other instances, such as under Liberty Street Bridge or Research Park Drive Bridge, the design will integrate into a more composed landscape such as a park or a constructed wetland. In those cases, the same trees will be planted and organized into the design plans for those areas.

**Plant Organization:** Naturalized tree massing of a size and area that creates a strong visual impact at the roadway level and underneath the bridge. In order to create the most impact, the tree shall be a single species with distinguishing features such as bark color and/or texture and/or fall color.

## Plant Materials

**Trees:** The best example of the type of tree that will have the height scale and distinguishing characteristics necessary to perform its function in this zone is the Sycamore (*Platanus Occidentalis*). Another choice, which actually is very different than the Sycamore, is the Bald Cypress (*Taxodium Distichum*).

## Water

**Irrigation:** Temporary only to establish plant materials

- ① Large-canopy trees
- ② Massings of mixed native wetland understory
- ③ Graded area for bio-retention and flood mitigation
- ④ Potential future roundabout



Example of Gateway Landscape Zone on the future interchange of US 52 and Salem Creek Connector



Example of Gateway Landscape Zone on Broad Street at the future extension of Martin Luther King Jr. Drive



# LANDSCAPE

## Traditional Streetscape

A large portion of the Corridors accommodates arterial roadways that have residences and business fronting on them, such as Martin Luther King Jr. Drive and Broad Street.

The design for the Traditional Streetscape Zone shall consider that these roadways and the land adjacent to them are in various stages of evolution. The design shall respond to existing constraints and, as much as possible, set a pattern that these streets can evolve into over a span of time as their traffic requirements evolve and as redevelopment occurs.

The design for the Traditional Streetscape shall also consider the design standards and guidelines of the Threshold Landscape Zone (page 83), as well as the Pedestrian Crossings Major and Minor Thresholds (page 75), so that they seamlessly fit together and become part of a singular composition.

**Design Intent:** The eventual outcome for the Traditional Streetscape Zone shall be to provide street trees at regular intervals and at a consistent dimension from the back of curb so that they create a canopy over the street, provide a pleasant and shady place for people to walk and separate the pedestrian environment from the roadway. All new roadway construction shall meet this expectation hereinafter referred to as the “Ideal Condition.”

In cases where the existing ROW does not allow for this in the near term, the design shall respond to an interim solution that places trees along the edge of the ROW, either in available space or within an easement behind the sidewalk. This condition shall hereinafter be referred to as “Interim Condition.” At such time as when the ROW expands, new development occurs along the ROW or the roadway itself gets reconfigured to a smaller cross section, new trees shall be planted to be consistent with the Ideal Condition as referenced above and described below.

**Plant Organization:** For the Ideal Condition, large canopy trees shall be planted at 40 feet on center at a consistent dimension of 3-4 feet from the back of curb. The trees shall be planted in a tree lawn or within tree grates, depending upon the nature of the development that occurs next to the street. The tree lawn shall be a consistent 6-8 feet wide and shall be designed to create a suitable soil and drainage environment for the trees to achieve optimal growing conditions.

For the Interim Condition, canopy trees and understory trees shall be planted in informal arrangements and shall “fill in” the areas not already covered in trees and landscape that extends parallel to the roadway. These tree massings shall be located behind the curb within the street ROW if space is available that is consistent with the Ideal Condition and/or within planting easements located on the properties that line the ROW.

**Medians:**  
As referenced previously, medians shall be a consistent expression for the entire length of the roadway.

## Plant Materials (Ideal Condition)

**Trees:** Red Maple or similar (Note: this Visionary Master Plan proposes using a different tree than for the Thresholds so that they are distinguished)

**Ground over in tree lawn:** Grasses or “rain garden” landscapes

## Plant Materials (Interim Condition)

**Trees:** Mixed native shade trees and understory massings

## Water

**Irrigation:** Temporary irrigation until plants become established or use of grey water or harvested water for irrigation

**Water Management:** In the Ideal Condition, the design of the tree lawn shall consider best practices, rain gardens or linear bio-retention areas to manage “first flush” surface water drainage from the street, while also enabling the proper environment to grow the street trees.

In the Interim Condition, the design team shall also consider the potential to integrate best practices into the available space between the curb and sidewalk.



# LANDSCAPE



Example of Interim Streetscape



Isometric of Interim Streetscape



Example of Ideal Future Streetscape



Isometric of Ideal Future Streetscape



# LANDSCAPE

The specific plant selection for the Corridors should be done with care being sensitive to choose plants that are low maintenance and that will be able to thrive in the Corridors in times of drought. Designs in the Corridors should be planted in massing and in grouping of plants that complement each other. The planting design shall conform to the NCDOT highway plant list (right) or be a non-invasive native plant. While any of the NCDOT plants are acceptable there are some plants that should be used in the Corridor throughout in their appropriate landscape typology.

## Trees

*Acer rubrum*, Red Maple  
*Acer saccharum*, Sugar Maple  
*Amelanchier arborea*, Downy Serviceberry  
*Betula nigra*, River Birch  
*Cercis canadensis*, Eastern Red Bud  
*Chionanthus virginicus*, White Fringetree  
*Cladrastis lutea (kentukea)*- American Yellowwood- L  
*Cornus kousa*, Korean Dogwood  
*Cryptomeria japonica*, Japanese Cryptomeria  
*Fagus grandiflora*, American Beech  
*Fraxinus pennsylvanica*, Green Ash  
*Halesia carolina*, Carolina Silverbell  
*Juniperus virginiana*- Eastern Red Cedar  
*Koelreuteria paniculata*, Golden Raintree  
*Lagerstroemia indica*, Crape Myrtle  
*Lagerstroemia fauriei*, Japanese Crape Myrtle  
*Liquidambar styraciflua*, Sweetgum  
*Liriodendron tulipifera*, Tulip Poplar  
*Magnolia grandiflora*, Southern Magnolia  
*Magnolia*- a large selection of deciduous native and cultivated magnolia species are worthy of use  
*Malus*, Flowering Crabapple  
*Metasequoia glyptostroboides*, Dawn Redwood  
*Nyssa sylvatica*, Black Gum  
*Oxydendrum arboreum*, Sourwood  
*Pinus taeda*, Loblolly Pine  
*Pinus thunbergiana*, Japanese Black Pine  
*Pinus virginiana*, Virginia Pine  
*Pistacia chinensis*, Chinese Pistachio

*Platanus x acerfolia*, London Plane Tree  
*Prunus mume*, Japanese Apricot  
*Prunus serrulata*, Japanese Flowering Cherry  
*Prunus subhirtella*, Higan Cherry  
*Prunus x yedoensis*- Yoshino Cherry  
*Quercus alba*, White Oak  
*Quercus acutissima*, Sawtooth Oak  
*Quercus coccinea*, Scarlet Oak  
*Quercus falcata*, Southern Red Oak  
*Quercus shumardii*, Shumard Oak  
*Quercus phellos*, Willow Oak  
*Quercus virginiana*, Live Oak  
*Sophora japonica*, Japanese Sophora  
*Taxodium distichum*, Bald Cypress  
*Tsuga caroliniana*, Carolina Hemlock  
*Vitex agnus-castus*, Chastetree  
*Zelkova serrata*, Japanese Zelkova

## Shrubs

*Abelia x grandiflora*- Glossy Abelia  
*Aesculus parviflora*, Bottlebrush Buckeye  
*Aronia arbutifolia*, Red Chokeberry  
*Berberis thunbergii*, Japanese Barberry  
*Buddleia davidii*, Butterfly-bush  
*Callicarpa americana*, American Beautyberry  
*Callicarpa dichotoma*, Purple Beautyberry  
*Caryopteris x clandonensis*, Bluebeard (or Blue-spirea)  
*Chaenomeles speciosa*, Common Flowering Quince  
*Clethra alnifolia*, Summersweet  
*Cornus alba*, Tatarian Dogwood  
*Cornus sericea*, Redosier Dogwood  
*Cotinus coggygria*, Smokebush  
*Euonymus alata 'compacta'*, Compact Burning-bush  
*Forsythia x intermedia*, Border Forsythia  
*Fothergilla gardenii*, Dwarf Fothergilla  
*Hamamelis virginiana*, Witchhazel  
*Hamamelis x intermedia*- group of hybrid Witchhazels  
*Hemerocallis*- Daylily  
*Hydrangea quercifolia*, Oakleaf Hydrangea  
*Hypericum frondosom*, Golden St. Johnswort  
*Ilex x attenuata*- group of hybrid hollies  
*Ilex cornuta*, Chinese Holly  
*Ilex crenata*, Japanese Holly  
*Ilex glabra*, Inkberry  
*Ilex latifolia*, Lusterleaf Holly  
*Ilex opaca*, American Holly  
*Ilex verticillata*, Winterberry  
*Ilex vomitoria*, Yaupon Holly

*Ilex x 'Nellie R. Stevens'*, Nellie R. Stevens Holly  
*Itea virginica*, Virginia Sweetspire  
*Jasminum nudiflorum*, Winter Jasmine  
*Juniperus*- multitude of junipers ideal for various landscape uses  
*Kerria japonica*, Japanese Kerria  
*Lagerstroemia*, Crape Myrtles  
*Liriope muscari*, Big Blue Liriope  
*Loropetalum chinense*, Loropetalum  
*Myrica cerifera*, Southern Wax Myrtle  
*Myrica pensylvanica*, Northern Bayberry  
*Osmanthus x fortunei*, Fortune's Osmanthus  
*Pyracantha coccinea*, Scarlet Firethorn  
*Pyracantha koidzumii*, Formosa Firethorn  
*Raphiolepis umbellata (indica)*, Indian Hawthorn  
*Spiraea cantoniensis*, Reeves Spirea  
*Spiraea x bumalda*- Bumald Spirea  
*Taxus x media*, Spreading Yew  
*Ternstroemia gymnanthera*, Japanese Cleyera  
*Viburnum*  
*Weigela florida*, Weigela



# LANDSCAPE

## Plant Themes

While all of the plants approved by the NCDOT are permissible in the corridors there are a few species that should be considered for each landscape zone. Using similar plant types in each zone creates unity throughout the Corridors and the repetition of plant species creates recognizable landscape zones that respond to the environment and physical surroundings. While these species are important, other plant species should also be incorporated as appropriate.

### Gateway Zone



*Metasequoia glyptostroboides*, Dawn Redwood - Gateway Zone to be used in a regular grid form that frames views to the City

### Parkway Zone



*Amelanchier arborea*, Downy Serviceberry - Parkway Zone to be used as an accent understory tree



*Oxydendrum arboreum*, Sourwood - Parkway Zone to be used as an accent tree

### Lowland Zone



*Betula nigra*, River Birch - Lowland Zone to be used as a tree that responds to the natural drainage systems

### Streetscape Zone



*Acer rubrum*, Red Maple - Streetscape Zone to be used as a street tree in regular or irregular rhythms



*Magnolia grandiflora*, Southern Magnolia - Gateway Zone to be used in a regular grid form that frames views to the City



*Cercis canadensis*, Eastern Red Bud - Parkway Zone to be used as an accent understory tree



*Sophora japonica*, Japanese Sophora - Parkway Zone to be used as an accent tree



*Juniperus virginiana*- Eastern Red Cedar - Lowland Zone to be used as an accent evergreen



*Platanus x acerfolia*, London Plane Tree - Streetscape Zone to be used as a street tree in regular or irregular rhythms



*Quercus phellos*, Willow Oak - Threshold Zone to be used as a street tree in regular rhythm in the threshold zones



*Malus*, Flowering Crabapple - Parkway Zone to be used as an accent understory tree



*Halesia carolina*, Carolina Silverbell - Parkway Zone to be used as an accent understory tree



# FIXTURES

## Corridor “Street” Lighting

The way that the Corridor is lit can provide a safe environment, be environmentally responsible and contribute to the overall aesthetics. There are generally two street lighting typologies: those which light the arterial roadways (which can be of smaller scale and more pedestrian friendly) and those which light the highway roadways (usually larger fixtures spaced further apart and light a broader area). Careful consideration should be given to both fixture types so they meet the minimum lighting required for safety - while not over-lighting the space, they utilize current best practices for reducing energy usage and light pollution, and they promote an attractive fixture that complements the overall design.

The fixtures selected shall be used throughout the length of those portions of the Corridors and both types shall also be complementary to each other in terms of color, style, detail, etc.

**Design Intent:** In no instance shall high mast lighting, which is out of scale and can contribute unnecessarily to light pollution, be allowed. As part of designing the lighting plan, careful consideration shall be given to only providing enough light to meet safety requirements. A minimum height, illumination and number of light masts shall be utilized. The design team shall also consider ambient light, as well as the artful lighting proposed for the bridge structure and median, when calculating the lighting requirements.

The light fixtures shall be selected based on their aesthetics as well as their compliance with environmental requirements, such as the use of full cut-off light fixtures. Consideration shall be given to both the spacing and height of the poles as well as reducing the amount of light provided so that the correct balance is achieved between good aesthetic design and responsible design.

The street lighting fixtures shall be contemporary designs and shall be clean and simple. No historically themed fixtures will be allowed. Ideally the chosen fixtures will include solar panels and wind turbine components to create energy for the fixture as well as to potentially provide energy back to the grid. The use of these types of fixtures is strongly encouraged if they also are clean, simple and attractive in appearance.

### Integration of Sustainability

- Energy-use reduction
- Light pollution reduction
- Passive energy creation

## Corridor Signage

### General

Signage is an important part of the aesthetics and shall be designed not only to enable clear wayfinding but also to promote cohesive design. Within state highways, certain federal and state highway design restrictions exist that limit design choices. The design team, however, shall stretch the potential of these limitations and create sign designs that not only meet technical requirements but achieve aesthetic objectives.

Beyond the sign panel itself, the key items to consider for the highway include consistency in pole type and material, placement so that signage does not detract from the other elements, and limitation of the signage to only those that are necessary or required. Within the arterial roadway Corridors, there may be more opportunities to expand upon the design expression. Any expansion of the design shall be done in recognition of the choices made for the highway, so consistency (in pole design, colors and font choices) is achieved.

It is highly recommended that a comprehensive and integrated signage plan be created that establishes a consistent pole type and form; creates a menu of sign designs that contribute to the brand image of the City and promotes the aesthetics of the corridor; and establishes the fonts, colors, materials and manufacturing details to be created prior to or in conjunction with the design of the first implementation phase. The overall signage plan shall encompass the corridors and include signage appropriate for highway as well as arterial roadways. It shall include provisions for bridge signage, overhead signage, street signage, speed limit signage and directional signage.

### Billboards

The billboards that exist adjacent to Business 40 present visual challenges to the Corridor and are located in an important space in the City (where the Liberty Street Bridge crosses the Strollway and where a new park and Signature Bridge are proposed). Every effort shall be made to remove or, at minimum, relocate these billboards to an acceptable location in accordance with state amortization procedures. Also, no new billboards should be allowed within the area known as the Creative Corridor.

### Integrated Bridge Signage

No signage shall be allowed on the Bridge structures except for carefully considered signage that becomes part of the Bridge's aesthetic composition. Such signage may be approved if it is part of a naming project or describes the street above. Acceptable locations include on the beam in a location that supports the composition of center and end pilasters or on the face of the abutment walls. The materials and colors must be harmonious with the Bridge structure so that they are integrated well and so the scale of the sign does not overwhelm the composition.

### Large Overhead Signage

Sign Bridges shall not be allowed. One-arm overhead signage shall be allowed so long as it includes a pole that is colored green and is arching. All overhead signage shall be the same.

### Large Freestanding Directional

Freestanding directional signage shall include provision for an attractive pole colored green to match the poles used for the overhead signage.

### Speed Limit

At minimum, speed limit signage shall include provision for an attractive pole colored green to match the pole used for the overhead signage.

### Street Names

At minimum, street names signs shall include provision for an attractive pole colored green to match the pole used for the overhead signage.

### Integration of Art

Although the signs need to conform to requirements established by NCDOT, they can also be designed so that they are highly aesthetic and representative of great graphic design.

### Integration of Environmental Sustainability

- Low VOC content materials
- Regionally extracted, processed and manufactured materials
- Recycled Content
- Proper disposal and diversion from landfill



# ARTFUL LIGHTING DESIGNS



Curving lighting display on bridge



Pedestrian bridge with accent lighting

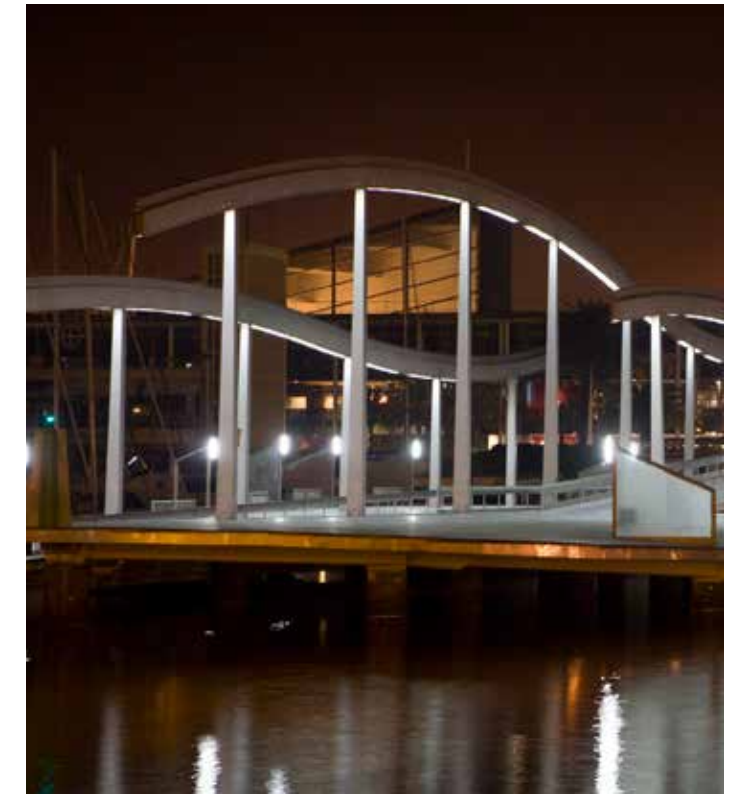

Architectural lighting



A unique experience is created with fun and original forms.

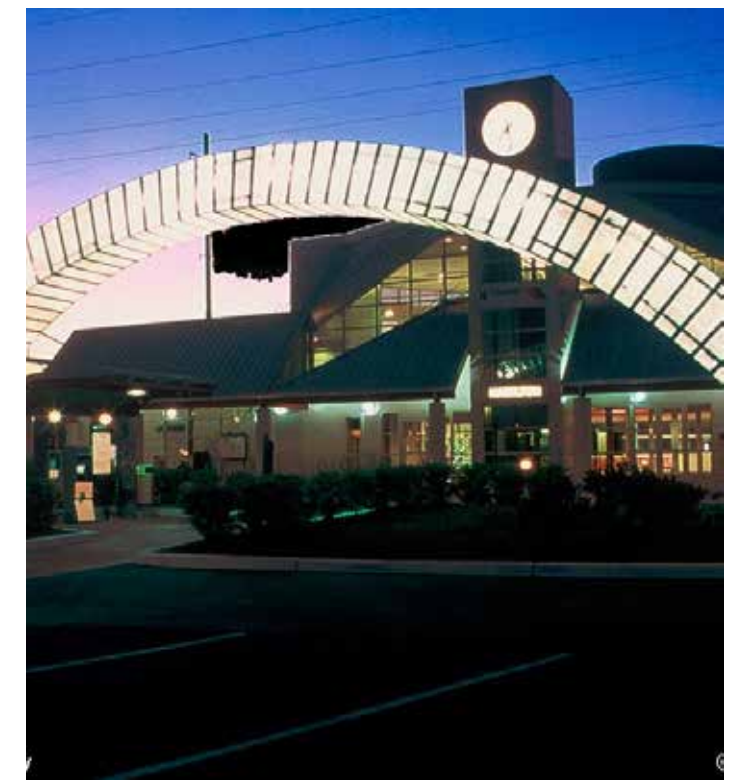

Arched gateway light





# ARTFUL WALLS AND FENCE DESIGNS



Gabion walls with pedestrian trail



Wall with inset art



Wall with green screen



Wall with native rock and pattern geologically inspired

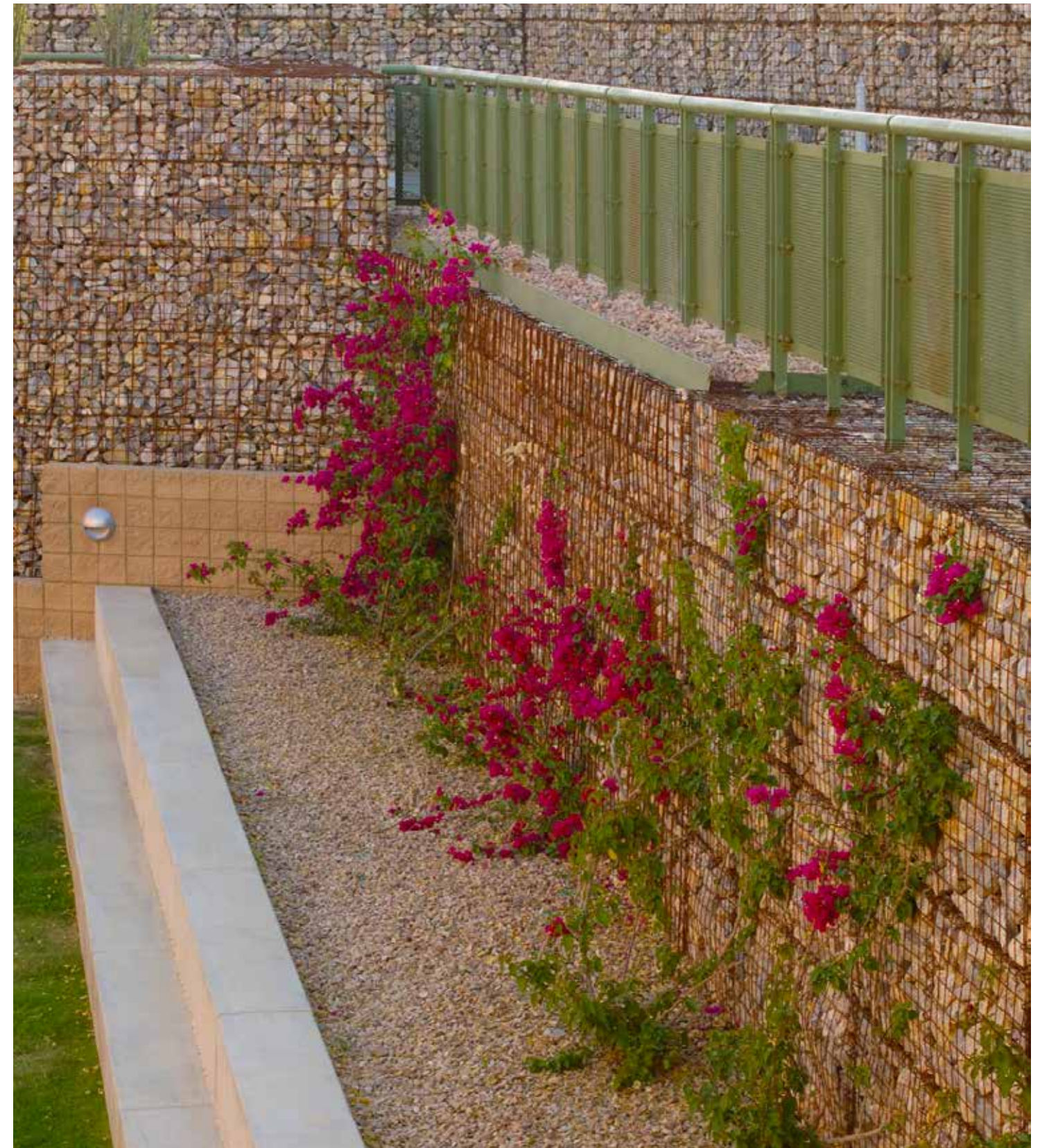

Gabion wall with colorful planting



# ARTFUL WALLS AND FENCE DESIGNS



Different materials and art integrated into retaining wall



Different textures inspired by local flora and fauna



Art integrated into wall



Artful bridge railing

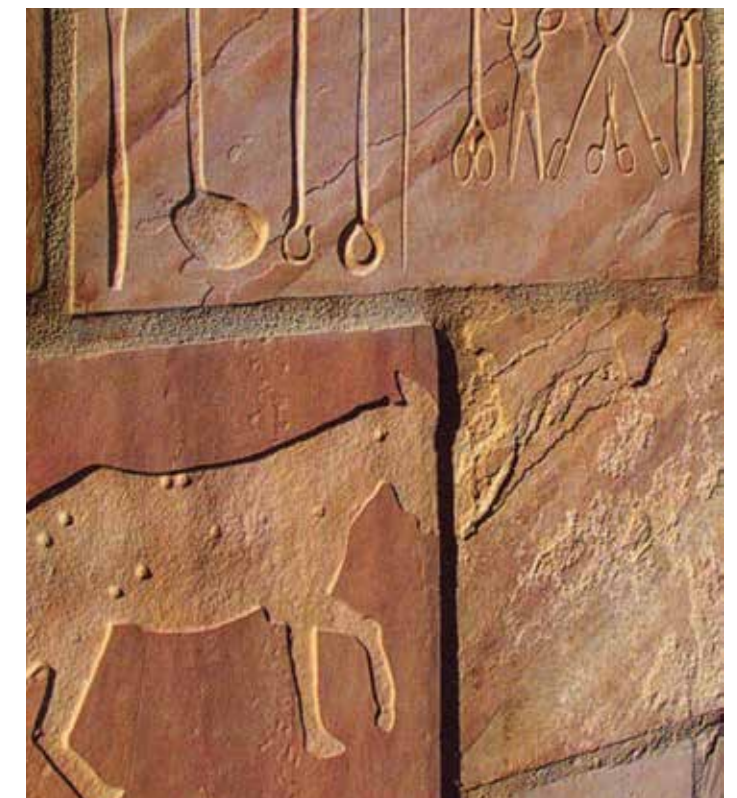

Art integrated into wall





 Green



 Artful



 Iconic



 Network



# 5

## PROCESS AND POLICY INTEGRATION OF ART AND ARTFUL DESIGN

Comprehensive integration of art into the overall project should represent an expression of our time and contribute to an enhanced identity of the City of Winston-Salem. The commission of the highest quality of artful public works along the Creative Corridors is essential. The Creative Corridors are described as the public facilities, infrastructure and roadways contained along major roadways (and all inclusive of their terminus intersections/interchanges) that encircle the City's central area including:

- Martin Luther King Jr. Drive from Business 40 to University Parkway.
- Broad Street from Peters Creek Parkway to Northwest Boulevard (future Martin Luther King Jr. Drive Extension).
- Peters Creek Parkway from Business 40 to Broad Street.
- US 52 from the future Salem Creek Connector (existing Vargrave Street) to Martin Luther King Jr. Drive.
- The future Salem Creek Connector from Martin Luther King Jr. Drive to the future Research Parkway.
- The future Research Parkway from Salem Creek Connector to Martin Luther King, Jr. Drive.
- The future Martin Luther King Jr. Drive Extension from University Parkway to Broad Street.
- Business 40 from Peters Creek Parkway to Martin Luther King Jr. Drive.

The Creative Corridors include many State-maintained rights-of-way. It is understood that the North Carolina Department of Transportation (NCDOT) is not required to adhere to local policy; the CCC will continue its efforts of seeking NCDOT's voluntary compliance. The Coalition and NCDOT have enjoyed healthy dialog throughout the process that produced the Visionary Master Plan and these guidelines are authored in a manner to comply with many of NCDOT's current initiatives and processes. The City of Winston Salem and the Creative Corridors Coalition shall seek to formalize its partnership with NCDOT to effectuate these standards on all roads designated as a Creative Corridor.



# PROCESSES AND POLICIES

All infrastructure projects with aesthetic consequences, as determined by the Planning Director of the City/County Planning Commission, within the Creative Corridors areas defined above shall be subject to this Chapter. Upon inclusion of an applicable project in the City's Capital Improvement Program (CIP) or other programmatic planning documents of the City Engineer, the NCDOT, the Winston-Salem Metropolitan Planning Organization (MPO), and/or similar entities, an artful designer (landscape architect, urban designer, planner, architect, structural engineer) or artist, as appropriate, shall be included as a fundamental part of the design team. As that all infrastructure projects require extensive planning and have interest among multiple disciplines, it is essential that the Planning Director be kept apprised of and participate in the design of all projects designated for the Creative Corridors.

Within the Creative Corridor area, there are three types of art installation processes:

- When iconic elements are designed and engineered in an artful way.
- When works of public art are integrated into the design and construction of the Creative Corridors.
- When public art is installed independent of the design and construction of the Creative Corridors.

## Master Plan Administration and Maintenance

Since the transportation improvement sites covered by the Visionary Master Plan and Design Guidelines (Master Plan) all lie within City limits, the City of Winston-Salem will have primary responsibility for assuring implementation of the Master Plan.

To facilitate a meaningful review process, the City Council shall create and appoint a Creative Corridors Design Review Committee. The purpose of the Committee is to review all plans and proposals from the City, NCDOT, or any other agency or organization, for roadway enhancements for major thoroughfares in the Creative Corridors study area and to make recommendations to the City Council, Transportation Advisory Committee, or NCDOT on the plans' consistency with the outcome objectives of the the Creative Corridors Master Plan and Design Guidelines.

The Committee shall be composed of eleven members of the public who are residents of Winston-Salem but not employees of the City of Winston-Salem. Members shall be recommended by the Mayor and approved by the City Council. The Mayor will seek candidates who have backgrounds or experiences in the fields of:

- 1) Architecture
- 2) Landscape Architecture
- 3) Artistic Design
- 4) Civil or Structural Engineering
- 5) Transportation

Five members, including the chief executive officer of the Coalition., shall be drawn from the Creative Corridors Coalition Board.

Members shall serve a four-year staggered terms with five of the initial eleven members being named to two-year terms and the remaining six being named to four-year terms. All members shall be eligible to serve an additional four-year term if reappointed by the City Council. The members of the Committee shall serve without compensation. Members of the Committee shall serve at the pleasure of the City Council, and may be removed by the City Council.

The Chair and Vice Chair shall each be one of the eleven voting members of the Committee. The Chair and Vice Chair will serve a one-year term and will be nominated and approved by the voting members of the Committee.

The City Manager's Office shall designate an Executive Secretary for the Committee. The Executive Secretary, subject to the direction of the Chair, shall keep or cause to be kept all records, and shall prepare all correspondence of the Committee for the signature of the Chair. The Executive Secretary shall keep the minutes of every meeting of the Committee.

Staff from the City/County Planning Department, the City Department of Transportation and the City Manager's Office will provide support to the Committee. Creative Corridors Coalition shall provide up to two individuals to serve as staff support.

The Committee shall meet when there are projects or plans to review. Special meetings will be called by the Chair or by any two (2) members of the Committee.

## Responsibilities

The scale, scope and multi-year duration of improvements within the Creative Corridors area will require close and continuing oversight and coordination. As custodians of the Master Plan, the responsibilities of the CCDRP and the Planning Department staff assigned to it shall include, but not be limited to:

- Communicating and representing the intent of the Master Plan as it relates to artful design.
- Coordinating communications related to the artful design of projects between the CDRP, the construction team, the artful designer, City Council, other City agencies and NCDOT.
- Participating in the creation of budgets for artful design and/or artwork.



## Funding for Artful Design

To execute thoughtful infrastructure projects within the Creative Corridors, it is essential that adequate funding is provided for creative design. To that end, 2% (two percent) of each project budget should be set aside and designated for artful project design and construction. Those set-aside funds are to be considered separate from basic design and engineering services, construction costs, and required landscaping. Any unused funds from those set aside shall accrue in a special reserve fund to be used for future design, construction and public art installation. Supplemental public and private funding may be necessary for projects that require funds beyond the required 2% set aside. The CCC shall be responsible for securing additional funding for such projects. The City Council may also authorize other organizations to contribute to the funding of Creative Corridors projects.

## Artful Designer Selection

Selecting artful designers who have the skill, experience and competence to execute artful designs within the Creative Corridors is one of the most important parts of achieving the ideal integration of art and design. The CCDRC shall be responsible for the artful designer selection process in all cases and in accordance with the provisions herein.

Once that process is completed, the CCDRC will forward the recommendation to the City Council as to consultant contract award.

## Design Review Process

In addition to normally required document submissions for City contracts, all entities contracted by the City to provide design and engineering services in the Creative Corridors area shall comply with the following CCDRC procedural steps in a timely fashion to guarantee that the aesthetic/artistic objectives of the Master Plan are met:

- Certify to the CCDRC that a thorough review of the Master Plan has been completed
- Participate in a pre-design phase briefing session with the CCDRC that establishes aesthetic/art objectives for the specific components to be designed and constructed by the contracted entity.
- Submit to the CCDRC for approval an Art or Artful Design Plan, including scaled models or technical drawings of proposed artwork with a statement about how the art advances themes and concepts promoted in the Master Plan.
- Prior to the commencement of construction of any Creative Corridors project, submit to CCDRC for review and approval final Construction documents indicating all variations from previously approved design documents