



**AUTOMOTIVE STORAGE EQUIPMENT
FOR YOUR CAR DEALERSHIP**



PARTS & SERVICE



2020 NEW PRODUCTS



R2V VERTICAL STORAGE SYSTEM

Vertical drawers will change the way you look at storage: They provide unimpeded access to their contents and eliminate the hard-to-reach areas found in traditional shelf storage. When floor space is limited, or when you want to maximize use of the height you have available, you can stack our new R2V vertical storage system on top of Rousseau R cabinets. There is no product on the market quite like the R2V. Find out more on pages 53 to 58.



SPECIALIZED UNITS

Every technician needs a workspace with the right dimensions and accessories for their specific task, be it tire alignment, quick oil changes or vehicle preparation. That's why we have updated the "Specialized Units" section with new workstations. View the models on pages 78 to 81.



CABINET FOR TWO USERS

It's now easy to have a toolbox for two different users. For users working on different shifts or at the same time, the "two users" option lets you create separate access for individual technicians by dividing the drawers into two equal banks. It is available for multi-drawer toolboxes and the R2V vertical storage system. See pages 59 and 60 for more details.



AN ERGONOMIC WORKSTATION

Finding the optimal storage for your tools depends on several factors, such as their function, weight and frequency of use. By analyzing how they are used, we can determine the best place and method to store them. Learn more in the new section called "An ergonomic workstation" on pages 4 and 5.

DESIGNED, DEVELOPED AND MANUFACTURED IN NORTH AMERICA

We invest heavily in product development, modernization of our facilities, new technologies and our employees to offer premium-quality products, from design to manufacturing to end product.

Our goal is to understand your requirements so we can create tailored solutions that meet your expectations and needs in terms of your environment (new construction or existing construction) and priorities.



SERVICE DEPARTMENT		2-3
Ergonomic Workstation		4-5
Create Your Own Workcenter		6-17
Double Workcenters		18-25
Single Workcenters		26-31
Corner Workstations		32-37
TekZone Hutch		38-41
Toolboxes		42-52
R2V Vertical Storage		53-58
Cabinet for two users		59-60
Reel Cabinets		61-64
Storage Units		65-68
Storage Units and Lockers		69-70
MultiTek Cart		71-77
Specialized Units		78-81
Basic Workbenches		82-86
Service Advisor Desks		87-93
Personalized Panels		94



PARTS DEPARTMENT		95-97
Small and Medium-Sized Parts Storage		98-105
Specialized Storage		106-109
Large Parts Storage		110-111
Multi-Level Shelving System		112-113
MultiTek Cart - Material Handling		114
Workstations		115
Service Counters		116-117
5S Storage		118-119
Cabinets for Specialized Tools		120
Drawer accessories		121-122
Case Studies		123-125
Showcase		126-136
Colors		137

SERVICE DEPARTMENT

A SERVICE DEPARTMENT IN YOUR OWN IMAGE

Rousseau's workcenters for technicians are the most complete and versatile solutions on the market. Our specialists will help you find a custom configuration that meets your unique requirements and reflects the professional image of your company.



Mercedes-Benz Winnipeg (MB)

A COMPLETE SOLUTION

We have the perfect solution, whether you are looking for basic workstations with a little or a lot of storage, or a more comprehensive workcenter with integrated lift motor control, computer systems, reels and much more.

We have a wide range of additional options, including MultiTek Carts for technicians, waste containers, utility panels and power feed panels, so you can add everything you need to your workstation.



A PERSONALIZED SOLUTION

Rousseau designs and manufactures its workstations with a height of 36" to ensure they are as ergonomic as possible. This is the perfect height to work standing up in a service department for the vast majority of people. However, if your team members need extra height, 40"H work surfaces are also available.



TRY OUT OUR BAY DESIGN TOOL!

Do you have an idea what kind of workcenter you need? If you do and would like a quick preview of what your ideal workcenter would look like, be sure to try out our Bay Design tool on rousseau-automotive.com. In just a few easy steps, you can configure your very own workcenter. If you can't find exactly what you're looking for with our Bay Design tool, don't worry. The tool only shows the most popular dimensions, options and accessories, but others are available. For a personalized solution, our team of specialists will suggest options and help you find a configuration that meets your requirements.

The Bay Design tool offers a way for you to create and preview a custom layout in just a few easy steps. When you're happy with your design, you can save it or request a quote with your desired specifications.

Give it a try!

NEED INSPIRATION?

Take a look at our Portfolio in the Information Center section on rousseau-automotive.com.

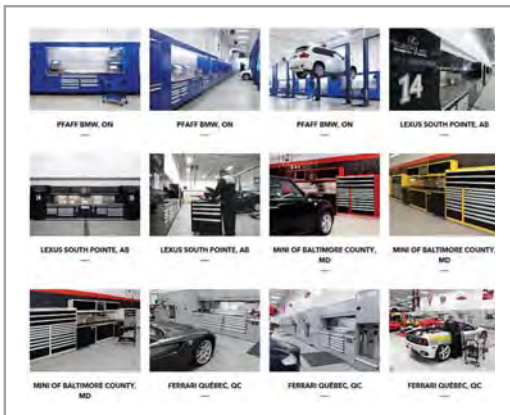
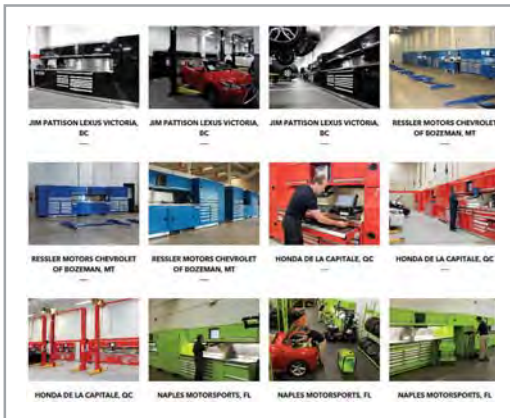

1



Enter the desired work surface width.

2



Click on each of the workcenter sections and choose the option that best suits your needs.



3

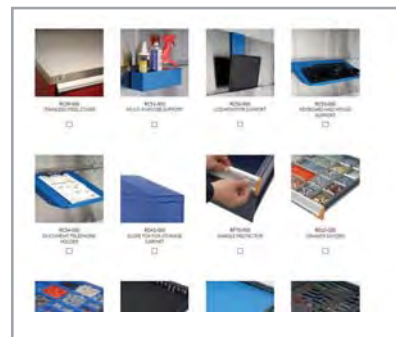

Choose accessories to complete your solution.

4

Share it, save it or request a quote.

FACTORS TO CONSIDER

The first step in creating an optimal storage solution is to list all the tools and items to be stored. You can't store all these items in the same cabinet, drawer or shelf, so you need to categorize them. To do this, there are four factors and four reach zones to consider when organizing your storage solution.



1- FREQUENCY OF USE

It's important to know how often your tools are used. This generally determines the location of your equipment. We can divide frequency of use into four categories: frequent, average, occasional and specific. We recommend storing frequently used items in easy-to-reach zones (green and yellow).

2- IMPORTANCE OF QUICK IDENTIFICATION

We recommend using the 5S methodology for organizing your tools. Items that need to be found or used quickly should be placed in easy-to-reach zones.

3- SIZE AND WEIGHT

The weight of items handled is another important factor to take into account. By considering this in conjunction with frequency of use, it's easier to determine the best storage location. A heavy item used frequently should always be stored where the risk of injury is lowest. This will rule out zones that are too high or too low. However, a less ergonomic location is suitable if the heavy item is not used frequently. We should only be retrieving light items in high-reach zones.

4- PURPOSE AND CATEGORY

In some situations, you might want to group several items together according to type or how they are used. For example, you may want to group all screwdrivers together in the same drawer, even if you don't use all sizes with the same frequency.



STORING AND ORGANIZING ITEMS

Place your items in the storage solution according to these four factors within the four zones shown here. In this illustration, we have used a person of average height. We recommend using a 50th percentile adult when more than one person works in the same space. See technical guide R69 for ergonomic designs for taller or smaller people.

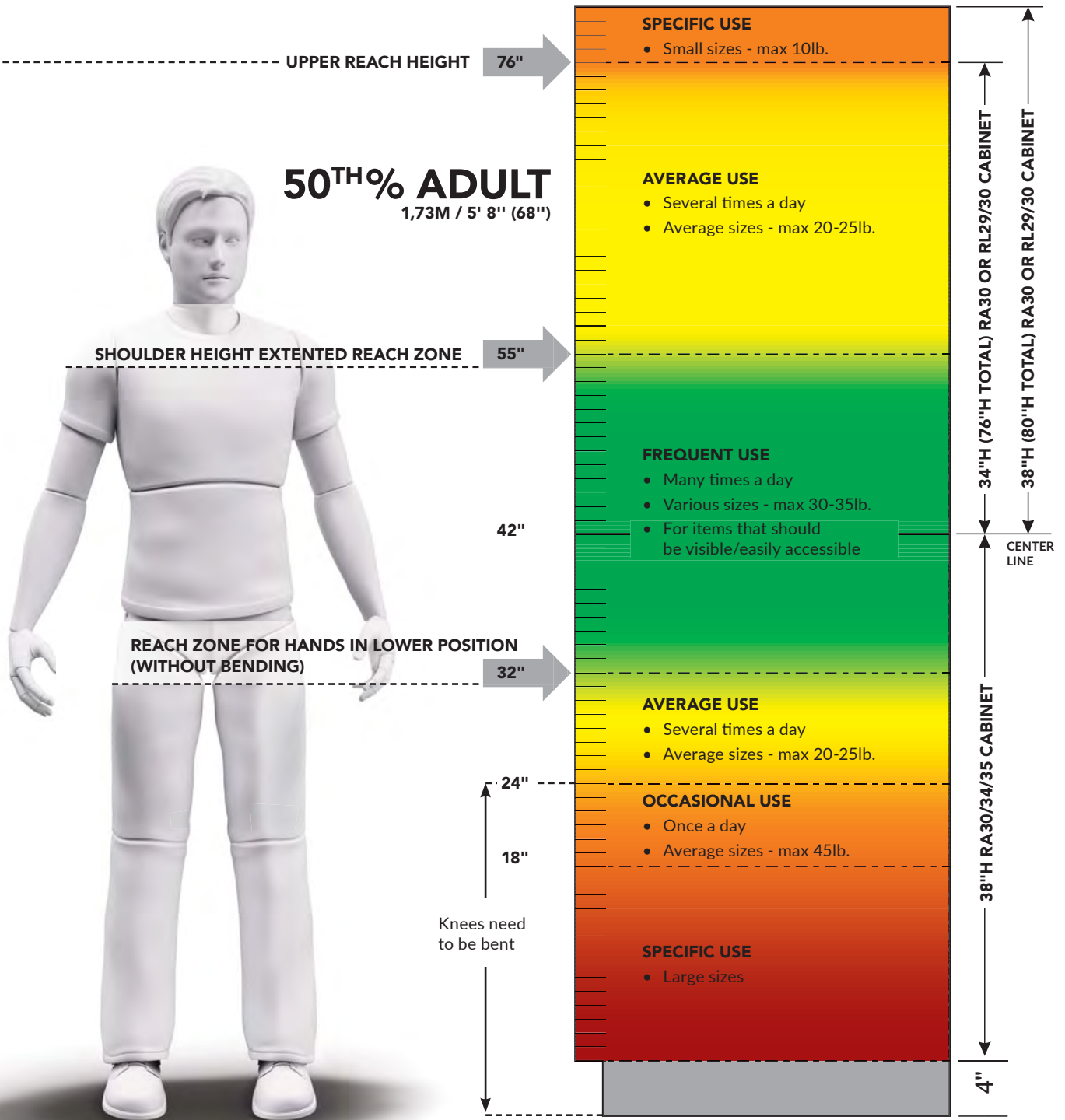

CREATE YOUR OWN WORKCENTER

5 EASY STEPS

Our specialists will work with you to evaluate the best configurations for your situation. They will take into consideration many different factors by asking various questions:

- What is the total amount of space available?
- Is computer access required?
- How much space is needed for tools?
- Where do the reels come from (air, electricity, oil, etc.)?
- How much space is needed for storage of bulky items?
- What type of lift do you use (integrated or posts, what brand)?
- Do you need task lighting?
- Etc.

In just five steps, we can help you create your own layout quickly and easily. The following pages take you through these steps.

SEE THE DIFFERENCE...



HOW TO CREATE YOUR OWN WORKCENTER

Following the steps below, you can create a custom layout by choosing models from those suggested on pages 18-31 (144"W, 120"W, 96"W, 84"W, 72"W, 60"W and 48"W models).

To order, complete the product numbers as shown in the steps below.

1 TYPE OF WORK SURFACE

Widths: 48", 60", 72", 84", 96", 120" and 144" (2 x 72")

Type of work surface: 16ga painted or stainless steel

Rubber mat available: Mats are 26" deep to accommodate tech uprights (RD44), cover panels (RC62/RC63/RC66/RC67/RC68/RC69) and power feed panels (RC60/RC61/RC64/RC65)

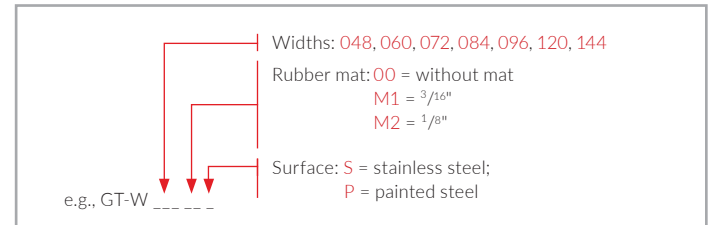

2 UNDER THE WORK SURFACE

The suggested models are some of the most popular. Simply add **S** to the end of the model number for a stainless steel base, or **P** for a painted steel base.

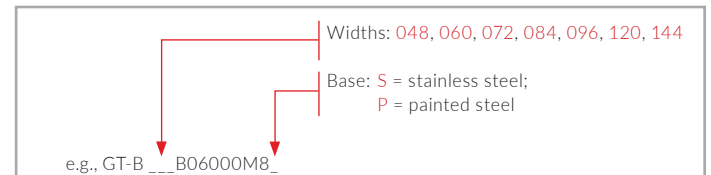

3 ABOVE THE WORK SURFACE

Widths: 48", 60", 72", 84", 96", 120" and 144" (2 x 72")

Includes: storage cabinet, computer cabinet, power feed panel, cover panel, tech uprights and panel support

Panel: painted or stainless steel

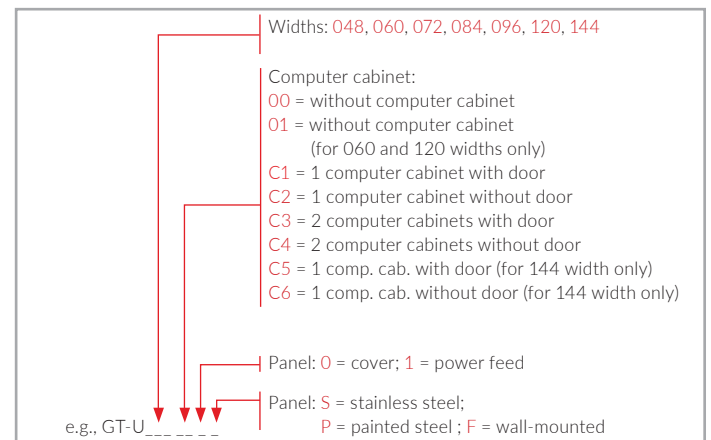

4 CENTER

4A WITH CABINETS

(ABOVE THE WORK SURFACE)

Widths: 48", 60", 72", 84", 96", 120" and 144" (2 x 72")

Includes: finishing panel, utility panel and plastic bin panel

Finishing and utility panel: painted or stainless steel

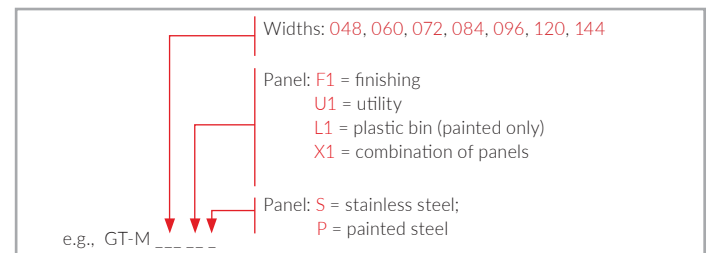

4B WITHOUT CABINETS

(ABOVE THE WORK SURFACE)

Widths: 48", 60", 72", 84", 96", 120" and 144" (2 x 72")

Includes: finishing panel, tech uprights, panel support, cover panel and power feed panel

Panel: painted or stainless steel

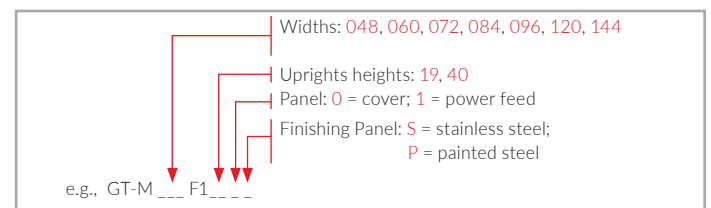

4C WITHOUT TECH UPRIGHTS

(ABOVE THE WORK SURFACE)

Widths: 48", 60", 72", 84", 96", 120" and 144" (2 x 72")

Includes: finishing panel for computer arm, cover panel and power feed panel without tech uprights, LCD monitor mount

Finishing panel: painted steel or stainless steel

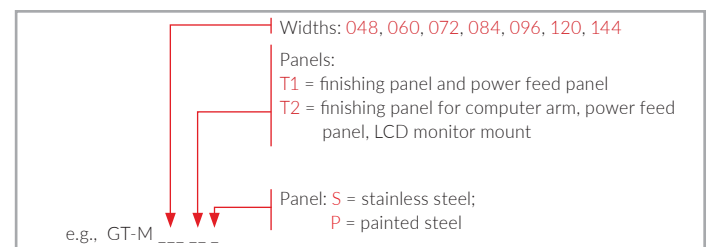

5 SIDES OF BAYS

17

1 TYPE OF WORK SURFACE

NOTE: THE WIDTH OF THE WORK SURFACE DETERMINES THE WIDTH FOR STEPS 2, 3 AND 4.

STAINLESS STEEL TOP



- Acts as a work surface and protects the top of the cabinet from impacts
- Particle board top with stainless steel cover (#4 brushed finish)
- Excellent chemical resistance
- Excellent corrosion resistance
- Welded corners for an attractive appearance
- Available in 12ga or 16ga steel (12ga steel top provides better impact resistance)
- 12ga top thickness: 1³/₁₆"
- 16ga top thickness: 1³/₄"

PRODUCT NO.	W × D
RC35-4830-__	48" × 30"
RC35-6030-__	60" × 30"
RC35-7230-__	72" × 30"
RC35-8430-__	84" × 30"
RC35-9630-__	96" × 30"
RC35-12030-__	120" × 30"

NOTES: Add 12 to the product number for a 12ga steel top.
For a 144"W workstation, order two 72"W tops.

MARINE EDGE STAINLESS STEEL TOP



- The edge stops hardware and liquids from falling off
- Acts as a work surface and protects the top of the cabinet from impacts
- Particle board top with stainless steel cover (#4 brushed finish)
- Excellent chemical resistance
- Excellent corrosion resistance
- Welded corners for an attractive appearance
- Available in 12ga or 16ga steel (12ga steel top provides better impact resistance)
- 12ga top thickness: 1³/₁₆" and 2" edge
- 16ga top thickness: 1³/₄" and 1⁵/₁₆" edge

PRODUCT NO.	W × D
RC35-4830-__M	48" × 30"
RC35-6030-__M	60" × 30"
RC35-7230-__M	72" × 30"
RC35-8430-__M	84" × 30"
RC35-9630-__M	96" × 30"
RC35-12030-__M	120" × 30"

NOTES: Add 12 to the product number for a 12ga steel top, or 16 for a 16ga steel top.
For a 144"W workstation, order two 72"W tops.

PAINTED STEEL TOP



- Acts as a work surface and protects the top of the cabinet from impacts
- Particle board top with painted steel cover
- Welded corners for an attractive appearance
- Thickness: 1³/₄"

PRODUCT NO.	W × D
RC37-4830	48" × 30"
RC37-6030	60" × 30"
RC37-7230	72" × 30"
RC37-8430	84" × 30"
RC37-9630	96" × 30"
RC37-12030	120" × 30"

NOTE: For a 144"W workstation, order two 72"W tops.

NEOPRENE RUBBER MAT



- Neoprene mat for protecting the work surface
- Thickness: 1/8"
- Order a 26"D mat for use with tech uprights, or 30"D for use without tech uprights.

WIDTH	DEPTH	
	26"	30"
48"	RG45-4826	RG45-4830
60"	RG45-6026	RG45-6030
72"	RG45-7226	RG45-7230
84"	RG45-8426	RG45-8430
96"	RG45-9626	RG45-9630
120"	RG45-12026	RG45-12030
144"	RG45-14426	RG45-14430

NOTE: Not compatible with the marine edge stainless steel top.

NITRILE RUBBER MAT

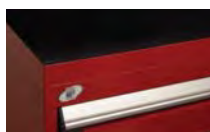

- Nitrile mat with excellent hydrocarbon and shock resistance
- Thickness: 3/16"
- Order a 26"D mat for use with tech uprights, or 30"D for use without tech uprights.

WIDTH	DEPTH	
	26"	30"
48"	RG48-4826	RG48-4830
60"	RG48-6026	RG48-6030
72"	RG48-7226	RG48-7230
84"	RG48-8426	RG48-8430
96"	RG48-9626	RG48-9630
120"	RG48-12026	RG48-12030
144"	RG48-14426	RG48-14430

NOTE: Not compatible with the marine edge stainless steel top.

2 UNDER THE WORK SURFACE

SLIDING LIFT MOTOR UNIT FOR ROTARY SHOCKWAVE™



- Quick and easy access to the lift control by sliding the unit out
- Easy access to the lift control on both sides
- Unit includes housing and a removable front
- 4"H base: painted or stainless steel
- Compatible with 120V only
- Optional leveling glides: RA75-01

PRODUCT NO.	TYPE OF BASE	W × D × H
RC05-18273401	Painted steel	18" × 27" × 34"
RC06-18273401	Stainless steel	18" × 27" × 34"
RC05-18273801	Painted steel	18" × 27" × 38"
RC06-18273801	Stainless steel	18" × 27" × 38"

STRUCTURAL CLOSED LEG



- Available for ends or middle of workstation
- Provides adequate support for integrating non-structural elements under the work surface (for over 18"W). Leg is 3" wide
- The middle leg can be used to create workstations wider than 72" without needing another structural element for support
- Two options available: Two 12A power outlets (for 15A circuit), or one 12A power outlet (for 15A circuit) with two USB ports
- Use a stringer (RC77) for applications that only use legs
- Two base types available (4"H): recessed or full depth
- The base is available in painted or stainless steel
- Includes leveling glides
- An inside finishing panel (RC74) is also available for a more finished look

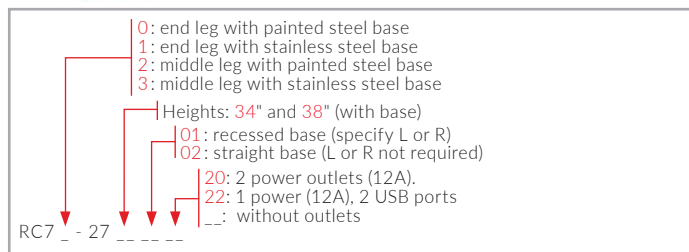

CROSSMEMBER



- Supports closed legs when used at the end of the workstation
- Connects the leg to another structural element on the workstation to provide extra rigidity at the bottom
- Stainless steel

PRODUCT NO.
RC78-__

NOTE: Complete the product number with the width required:
 18", 21", 24", 27", 30", 36", 42" or 48".

SLIDING LIFT MOTOR UNIT



- Quick and easy access to the lift control by sliding the unit out
- Easy access to the lift control on both sides
- Available for Rotary Mechanical, Rotary inground SmartLift®, Challenger with BMC, Challenger AquaVantage and Challenger EnviroLift®
- Includes housing
- 4"H base: painted or stainless steel
- Compatible with 220 V only
- Optional leveling glides: RA75-01

PRODUCT NO.	TYPE OF LIFT
RC_-1227_01	Challenger with BMC (controls on the workstation)
RC_-1227_05	Rotary inground SmartLift® (2007 version to present)
RC_-1227_06	Challenger AquaVantage
RC_-1227_07	Rotary Mechanical (conventional controls, September 2010 to present)
RC_-1227_08	Challenger EnviroLift® without BMC before 2015
RC_-1227_09	Challenger with BMC (controls integrated into sliding lift motor unit)
RC_-1227_10	Challenger EnviroLift® without BMC after 2015

NOTES: Add 20 to the RC__ product number for a painted steel base, or 21 for a stainless steel base.
 Add 34 to the product number for a 36"H workstation, or 38 for a 40"H workstation.

HIDEAWAY DOOR



- Designed to conceal waste containers (RK06), MultiTek Carts and L Mobile Cabinets under the work surface
- Includes a handle to easily open the door
- Available with or without a lock

PRODUCT NO.	W × H	NOMINAL HEIGHT
RB52-1834_ _ _	18" × 34"	30"
RB52-2134_ _ _	21" × 34"	30"
RB52-2434_ _ _	24" × 34"	30"
RB52-2734_ _ _	27" × 34"	30"
RB52-1838_ _ _	18" × 38"	34"
RB52-2138_ _ _	21" × 38"	34"
RB52-2438_ _ _	24" × 38"	34"
RB52-2738_ _ _	27" × 38"	34"

NOTES: Add L3 to the end of the product number to order a hideaway door with lock.
 Add L to the end of the product number to have the hinges on the left or R for the hinges on the right.

Order a 21"W or 24"W hideaway door to fit an L Mobile Cabinet.

DOOR EXTENSION



- Compatible with RB52 Hideaway Door
- Provides an immaculate finish
- Available in painted steel or stainless steel
- Compatible with a 23"W MultiTek Cart

PRODUCT NO.	W × H
RB_-180401	18" × 4"
RB_-210401	21" × 4"
RB_-240401	24" × 4"
RB_-270401	27" × 4"

NOTE: Add 59 to the product number for a painted steel extension or 60 for a stainless steel extension.

2 UNDER THE WORK SURFACE

WASTE & RECYCLING DOOR



- Designed to seamlessly integrate waste and recycling containers (RK08/RK09) under the work surface without affecting the usable surface area
- Includes a stainless steel flipper door for discarding waste without needing to open the panel
- A panel support (RB57) must be ordered for units installed at the end of a bay
- A base (RA59/RA60) must be ordered for seamless integration under the work surface

PRODUCT NO.	HINGE	HEIGHT
RB53-2434L	Left	34"
RB53-2434R	Right	34"
RB53-2438L	Left	38"
RB53-2438R	Right	38"

WASTE & RECYCLING DOORS **NEW**

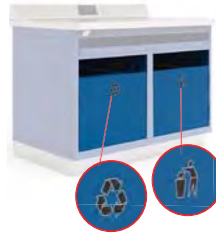

- Hide RK10 Waste & Recycling Containers under the work surface
- The doors are not full height so users can dispose of waste without opening the door
- Include hinges for opening door when emptying containers
- Include magnets to keep the door closed
- Include self-adhesive labels attached to the doors to identify the waste and recycling sides

PRODUCT NO.		WIDTH
RB58-24__-01L	Recycling	24"
RB58-24__-02R	Waste	24"
RB58-30__-01L	Recycling	30"
RB58-30__-02R	Waste	30"

NOTES: 17"H panels are recommended for 36"H workstations; 21"H panels are recommended for 40"H workstations.

Complete the product number with the height required: **17"** or **21"**.

By default, the recycling door is on the left and the waste door is on the right.

WASTE & RECYCLING DRAWER



- Used for sorting waste and items for recycling
- Logos on the side to facilitate sorting
- Drawer heights available: 17" and 26"
- Holds two containers (one black and one blue) with a divider that secures the containers and allows items to be stored behind

PRODUCT NO.	W × D × H	CONTAINER SIZE
R51CG-X1701	24" × 27" × 17"	Small (7 gallons/26.5 liters)
R51DG-X1701	30" × 27" × 17"	Small (7 gallons/26.5 liters)
R51CG-X2601	24" × 27" × 26"	Large (10 gallons/39 liters)
R51DG-X2601	30" × 27" × 26"	Large (10 gallons/39 liters)

WASTE CONTAINER



- Capacity: 28 gallons (the square bin has 14% greater capacity than the round bin)
- Rounded corners for easier cleaning
- Dimensions: 21 ½"W (25"W with handles) × 21 ½"D × 22 ½"H
- Optional door is available for seamless integration under the work surface (RB52)
- Mobile pedestal also available (RK07)

PRODUCT NO.	INCLUDES
RK06-01	Waste container
RK07-01	Mobile pedestal

WASTE & RECYCLING CABINET



- Can be used as a standalone unit, as part of a cabinet configuration or integrated underneath the work surface
- Used for sorting waste and items for recycling
- The 30"H unit includes a 26"H drawer with labeled handle to facilitate sorting; the 34"H unit also includes a 4"H drawer
- Includes two 15 ¼"W × 11"D × 20"H containers: a black one for waste (RK09-02) and a blue one for recycling (RK09-01)
- The drawer includes a divider which secures the containers and also allows items to be stored behind
- Optional leveling glides: RA74-01

PRODUCT NO.	W × D × H	WORKSTATION HEIGHT
GT-5ACG30050_	24" × 27" × 34"	36"
GT-5ACG34050_	24" × 27" × 38"	40"
GT-5ADG30050_	30" × 27" × 34"	36"
GT-5ADG34050_	30" × 27" × 38"	40"

WASTE AND RECYCLING CONTAINERS **NEW**



RK08/09



RK10

- Used for sorting waste and items for recycling
- 3 sizes:
 - **Small** (14 ¾"W × 10 ¼"D × 15"H) for a 17"H Waste & Recycling Drawer (R51CG-X1701 and R51DG-X1701)
 - **Large** (15 ¼"W × 11"D × 20"H) for use with an RB53 Waste & Recycling Door or a 26"H Waste & Recycling Drawer (R51CG-X2601 and R51DG-X2601)
 - **Extra large** (18 ¾"W × 23 ½"D × 16 ½"H) recommended for RB58 Waste & Recycling Doors

PRODUCT NO.	SIZE	COLOR
RK08-01	Small (7 gallons/26.5 liters)	Blue
RK08-02	Small (7 gallons/26.5 liters)	Black
RK09-01	Large (10 gallons/39 liters)	Blue
RK09-02	Large (10 gallons/39 liters)	Black
RK10-01	Extra large (18 gallons/68 liters)	Blue
RK10-02	Extra large (18 gallons/68 liters)	Beige

NOTE: Add **S** to the end of the product number for a stainless steel base or **P** for a painted steel base.

3 ABOVE THE WORK SURFACE

WITHOUT UPRIGHTS

LCD MONITOR ARM



- Compatible with most LCD monitors (max. 21") on the market
- Complies with VESA 75 and 100 monitor mounting standards
- Includes one or two articulating arm(s) with two joints
- The articulating arm with two joints provides extra adjustment options
- Monitor can be rotated and tilted
- Single and dual arm versions are available

PRODUCT NO.	FOR
RC59-03	Single monitor
RC59-04	Two monitors

LAPTOP ARM



- Holds a laptop, electronic device or any other object
- Tray's usable area: 14"W x 12"D
- Includes an articulating arm with two joints
- The articulating arm with two joints provides extra adjustment options
- Tray can be rotated and tilted

PRODUCT NO.	FOR
RC59-42	

LCD MONITOR MOUNT AND KEYBOARD & MOUSE ARM



- Holds a computer monitor, keyboard and mouse
- Keyboard tray's usable area: 23½"W x 8½"D
- Includes an articulating arm with a single joint
- Compatible with most LCD monitors (max. 21") on the market
- Complies with VESA 75 and 100 monitor mounting standards
- Monitor and tray can be rotated and tilted

PRODUCT NO.	FOR
RC59-21	

TABLET ARM



- Compatible with most tablets on the market
- The clamps and mount have a non-slip surface to keep the tablet stable
- Includes an articulating arm with two joints
- The articulating arm with two joints provides extra adjustment options
- Tablet can be rotated and tilted
- Compatible tablet sizes:
 - Small: 7¾"W to 10"W
 - Large: 9¾"W to 12¼"W

PRODUCT NO.	FOR
RC59-62-01	Small
RC59-62-02	Large

COVER PANEL FOR COMPUTER MOUNTS

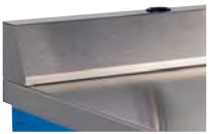

- Provides a more aesthetic finish when installing computer mounts (RC59-03/RC59-04/RC59-21/RC59-42/RC59-62-01/02)
- Width: 24"
- Can be combined with a power feed panel (RC64/RC65) or cover panel (RC66/RC67) if required
- Available in painted steel or stainless steel

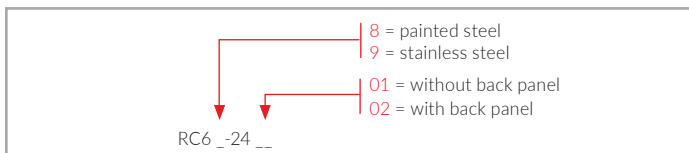

POWER FEED PANEL WITHOUT UPRIGHTS



- Includes a power bar with three 12A outlets for a 15A circuit
- Additional versions available: with a knockout for a pneumatic connection and a perforation (with a cover plate) for a telephone / Ethernet jack; or with two USB ports; or with knockout, perforation and two USB ports
- Installs on RC35 and RC37 tops
- Available in painted steel or stainless steel

COVER PANEL WITHOUT UPRIGHTS



- Can be combined with a power feed panel when necessary, or used on its own for a perfect finish
- Available in stainless or painted steel

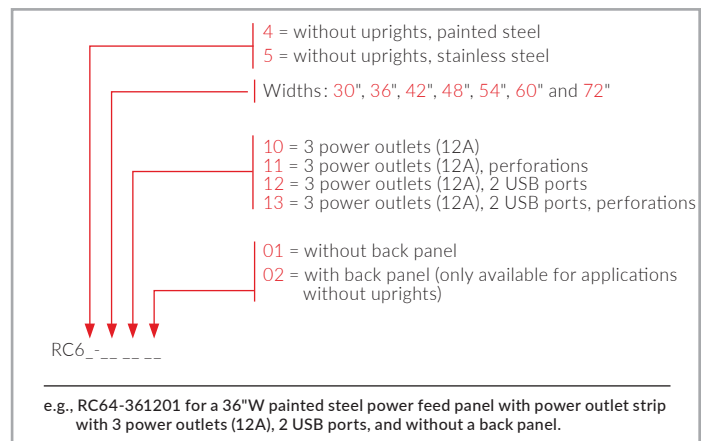
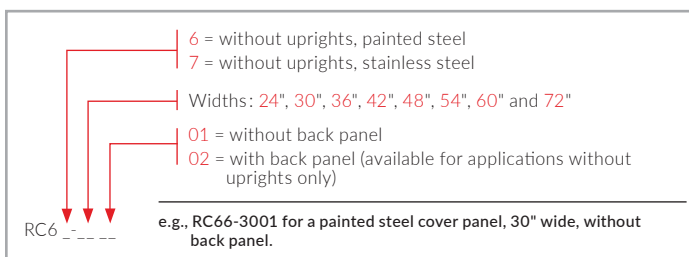

3 ABOVE THE WORK SURFACE

TECH UPRIGHTS



- For installation of a storage cabinet (RD02), computer cabinet (R5MCA), panel support (RC47), power feed panels (RC60/RC61) and cover panels (RC62/RC63)
- Allows height of cabinets to be adjusted in 4" increments
- Anchors securely to the work surface

PRODUCT NO.	HEIGHT
RD44-19	19"
RD44-40	40"

PANEL SUPPORT



- Supports finishing panels (RC41/RC42), plastic bin panels (RC45), utility panels (RC93/RC94) and finishing panels for computer arm (RC81/RC82)
- Enables a combination of different panel types to be installed

PRODUCT NO.	WIDTH
RC47-24__	24"
RC47-30__	30"
RC47-36__	36"
RC47-42__	42"
RC47-48__	48"
RC47-60__	60"

NOTES: For 19" RD44 uprights, add **03** to the number.
For 40" RD44 uprights, add **01** to the number for the lower section and **02** for the upper section.

FLIPPER DOOR STORAGE CABINET



- Can be wall mounted or installed on RD44 tech uprights
- The back is removable when wall mounted allowing easy access to electrical components (power outlets)
- The flipper door has a large handle for a comfortable grip (RD20)
- Optional lamp produces optimized lighting (RD45)

PRODUCT NO.	W × D × H
R5MCB-2111	24" × 14" × 21"
R5MDB-2111	30" × 14" × 21"
R5MEB-2111	36" × 14" × 21"
R5MHB-2111	42" × 14" × 21"
R5MGB-2111	48" × 14" × 21"
R5MKB-2111	60" × 14" × 21"

NOTE: Flipper door storage cabinets include an L3 standard lock. For an L50 electronic door lock, contact Customer Service.

SLIDING DOOR STORAGE CABINET



- Can be wall mounted or installed on RD44 tech uprights
- The back is removable when wall mounted allowing electrical components to be hidden
- Integrated door provides maximum clearance for handling items stored in the cabinet
- Polycarbonate door provides excellent impact resistance

PRODUCT NO.	W × D × H
R5MEB-21__	36" × 14" × 21"
R5MHB-21__	42" × 14" × 21"
R5MGB-21__	48" × 14" × 21"
R5MKB-21__	60" × 14" × 21"

NOTE: Add **07** to the product number for a solid integrated door or **08** for a polycarbonate integrated door.

SLOPED TOP FOR STORAGE CABINET AND COMPUTER CABINET



- Keeps the workspace clean and safe while reducing clutter
- Fits perfectly into the "5S" storage method
- 35° sloped top for computer cabinet and storage cabinet
- The top for computer cabinets includes a fan
- Height: 8"

PRODUCT NO.	FOR	W × D
RD42-241408	Storage cabinet	24" × 14"
RD42-301408	Storage cabinet	30" × 14"
RD42-361408	Storage cabinet	36" × 14"
RD42-421408	Storage cabinet	42" × 14"
RD42-481408	Storage cabinet	48" × 14"
RD42-601408	Storage cabinet	60" × 14"
RD43-241408	Computer cabinet	24" × 14"



GT-C1167S

3 ABOVE THE WORK SURFACE

COMPUTER CABINET



- Includes a monitor mount to create room for a CPU and LCD monitor
- Available with fan (for standalone use) or without fan (for use with sloped top)
- Includes a power outlet strip
- The keyboard tray (optional) can be tucked away under the cabinet when not in use
- The polycarbonate door (optional) is de-magnetized to eliminate image distortion
- Width: 24"

R5MCA-24 __

- 5 = with fan
- 6 = without fan
- 0 = wall-mounted housing only
- 1 = wall-mounted housing with polycarbonate door
- 2 = wall-mounted housing with keyboard tray
- 3 = wall-mounted housing with polycarbonate door and keyboard tray

LAPTOP, KEYBOARD & MOUSE TRAY



- Allows a laptop or keyboard and mouse to be used under a cabinet. Maximum laptop screen size: 15"
- Tucks away under the cabinet when not in use
- Tilts 17° when pulled out
- Includes a neoprene mat for better grip underneath the laptop or keyboard and mouse
- Opens easily and smoothly

PRODUCT NO.

RD47-2414

STORAGE UNIT



- Installs underneath a storage cabinet with or without an RD47 Laptop, Keyboard & Mouse Tray
- Can be installed underneath a computer cabinet with or without an RD47 Laptop, Keyboard & Mouse Tray
- Provides extra storage space
- Allows Laptop, Keyboard & Mouse Tray to be lowered by 4"
- Width: 24"

COMPLETE THE PRODUCT NUMBER ACCORDING TO YOUR PREFERRED SOLUTION:

	Storage cabinet	Computer cabinet
With RD47	01	01
Without RD47	03	01

PRODUCT NO.

RD48-241404 __

LED LIGHT



- Brighter and more energy efficient than a fluorescent tube
- Brightens shaded areas under cabinets
- Can be installed under RD00/RD02 cabinets
- Color temperature: 6000-7000K (cool)
- Includes a galvanized steel adapter
- Includes a 10' power cord
- The recommended operating temperature for our LED lights is between 5 and 40 °C (41 to 104 °F)
- An optional motion sensor can be added

PRODUCT NO. STORAGE CABINET WIDTH

RD45-1814 __	24"
RD45-2414 __	30", 36"
RD45-3614 __	42", 48", 24" + 24"
RD45-4814 __	60", 30" + 30"
RD45-6014 __	36" + 36"

NOTES: To order an LED light with motion sensor, add MS to the product number.

Not compatible with computer cabinets.

CONNECTING CABLE



- Up to 7 lights can be connected in series
- Each light is independent and controlled by its own switch

PRODUCT NO. CABLE LENGTH

70001108	8"
70001112	12"
70001124	24"

PLASTIC WRAP ROLL HOLDER



- Ideal for rolls of protective plastic for car seats
- Installs under an RD02 storage cabinet
- Total load capacity: 50lb.

PRODUCT NO. WIDTH

RD46-4814	48"
RD46-6014	60"

NOTE: Not compatible with LED light.

3 ABOVE THE WORK SURFACE

POWER FEED PANEL WITH UPRIGHTS



- Includes a power bar with three 12A outlets for a 15A circuit
- Additional versions available: with a knockout for a pneumatic connection and a perforation (with a cover plate) for a telephone/Ethernet jack; or with two USB ports; or with knockout, perforation and two USB ports
- Installs on RC35 and RC37 tops
- Designed for use with tech uprights (RD44)
- Available in painted steel or stainless steel

COVER PANEL WITH UPRIGHTS



- Can be combined with a power feed panel or used on its own to cover the feet of tech uprights for an immaculate finish
- Designed for use with tech uprights (RD44);
- Available in painted steel or stainless steel

RC6_ _ _ _ 01

- 0 = with uprights, painted steel
- 1 = with uprights, stainless steel

Widths: 30", 36", 42", 48" and 60"

- 10 = 3 power outlets (12A)
- 11 = 3 power outlets (12A), perforations
- 12 = 3 power outlets (12A), 2 USB ports
- 13 = 3 power outlets (12A), 2 USB ports, perforations

e.g., RC61-361201 for a 36"W stainless steel power feed panel with uprights, with a power outlet strip with 3 power outlets (12A) and 2 USB ports.

RC6_ _ _ _ 01

- 2 = with uprights, painted steel
- 3 = with uprights, stainless steel

Widths: 24", 30", 36", 42", 48" and 60"

e.g., RC62-3001 for a 30"W painted steel cover panel with uprights.



10 = 3 power outlets (12A) for 15A circuit



11 = 3 power outlets (12A) for 15A circuit, a knockout for a pneumatic connection and a perforation (with cover plate) for installing a telephone or network jack



12 = 3 power outlets (12A) for 15A circuit and 2 USB ports



13 = 3 power outlets (12A) for 15A circuit, 2 USB ports, a knockout for a pneumatic connection and a perforation (with cover plate) for installing a telephone or network jack

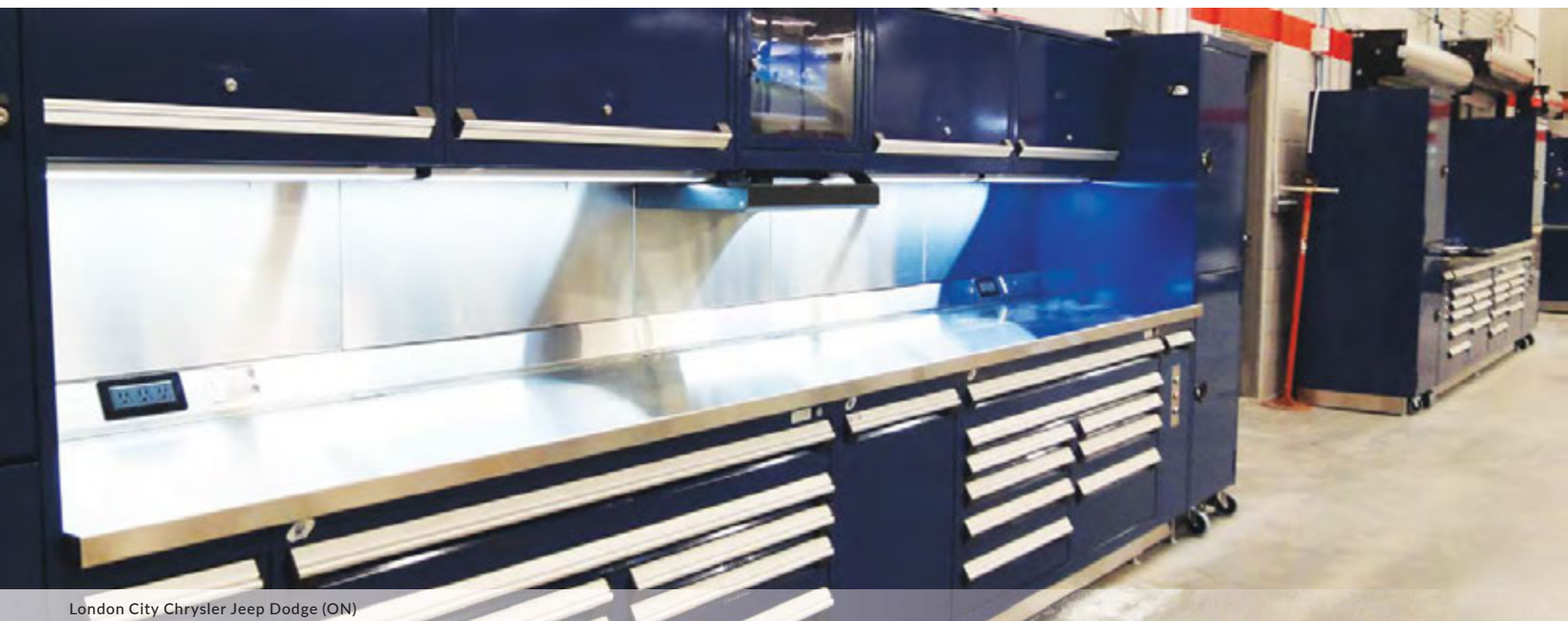

UTILITY PANEL

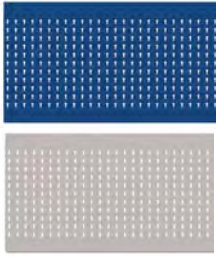

- Includes perforations spaced 1" apart c/c and is compatible with all WM9_ hooks and holders (see page 119)

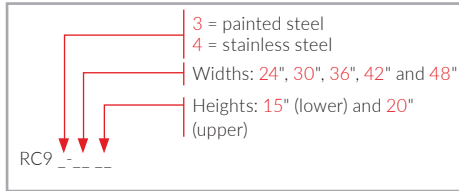

PLASTIC BIN PANEL



- Compatible with RG20 plastic bins (see page 118) and all brands of plastic bins with hanging lip on the market

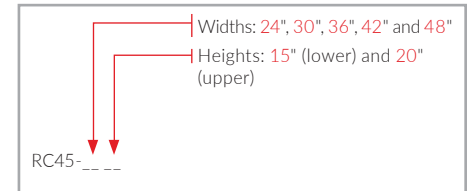

FINISHING PANEL

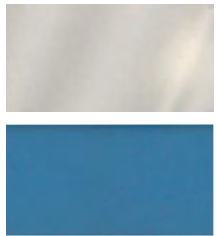

- Provides an immaculate finish
- Available in painted and stainless steel
- Can be used with or without a cabinet on top
- Two panels can be stacked (15"H + 20"H) to create a full height wall, which can hold accessories as needed
- Panels are compatible with the following accessories: multi-purpose holders (RC51), LCD monitor mounts (RC52), keyboard & mouse tray (RC53), multi-purpose supports (RC54)

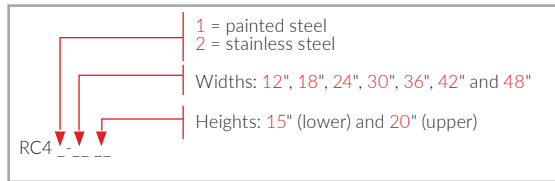

FINISHING PANEL FOR COMPUTER ARM



- Available in painted and stainless steel
- Can be used with or without a cabinet on top
- Two panels can be stacked (15" + 20")
- Panels are compatible with the following accessories: RC58-03/RC58-21/RC58-42/RC58-62
- Includes perforation for running cables through
- Width: 12"

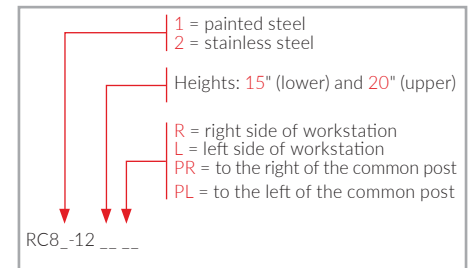
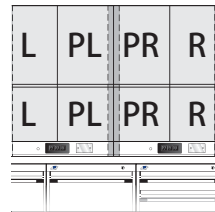

MULTI-PURPOSE HOLDER



- Holds up to 4 aerosol cans
- Also compatible with drinks cans
- Hooks securely onto RC41/RC42/RC93/RC94/RC45 panels
- Can be installed anywhere across the width of the bay

PRODUCT NO.	COMBINATION
RC51-120303	Panels only
RC51-120312	Panels and storage cabinets



PHONE AND DOCUMENT HOLDER



- Usable surface area: 14"W x 12"D
- Includes a clip to keep documents in place
- Hooks securely onto RC41/RC42/RC93/RC94/RC45 panels
- Can be installed anywhere across the width of the bay

PRODUCT NO.	COMBINATION
RC54-1412	Panels only
RC54-141202	Panels and storage cabinets



GT-C2047S

4 CENTER

LCD MONITOR ARM



- Compatible with most LCD monitors (max. 21") on the market
- Complies with VESA 75 and 100 monitor mounting standards
- Includes one or two articulating arm(s) with two joints
- The articulating arm with two joints provides extra adjustment options
- Monitor can be rotated and tilted
- Installs on a lower (15") finishing panel for computer arm (RS81/RS82)

PRODUCT NO.
RC58-03

LAPTOP ARM



- Holds a laptop, electronic device or any other object
- Tray's usable area: 14"W x 12"D
- Includes an articulating arm with two joints
- The articulating arm with two joints provides extra adjustment options
- Tray can be rotated and tilted
- Installs on a lower (15) finishing panel for computer arm (RC81/ RC82)

PRODUCT NO.
RC58-42

LCD MONITOR MOUNT AND KEYBOARD & MOUSE ARM



- Holds a computer monitor, keyboard and mouse
- Keyboard tray's usable area: 23½"W x 8½"D
- Includes an articulating arm with a single joint
- Compatible with most LCD monitors (max. 21") on the market
- Complies with VESA 75 and 100 monitor mounting standards
- Monitor and tray can be rotated and tilted
- Installs on a lower (15) or upper (20) finishing panel for computer arm (RC81/RC82)

PRODUCT NO.
RC58-21

TABLET ARM



- Compatible with most tablets on the market
- The clamps and mount have a non-slip surface to keep the tablet stable
- Includes an articulating arm with two joints
- The articulating arm with two joints provides extra adjustment options
- Tablet can be rotated and tilted
- Installs on a lower (15") finishing panel for computer arm (RS81/RS82)
- Compatible tablet sizes:
 - Small: 7⅞"W to 10"W
 - Large: 9⅞"W to 12¼"W

PRODUCT NO.	FOR
RC58-62-01	Small
RC58-62-02	Large

KEYBOARD & MOUSE TRAY



- Usable surface area: 24"W x 12"D for a keyboard and mouse
- Includes a series of bends at the front (¾" surface) that act as a palm rest
- Hooks securely onto RC41/RC42/RC93/RC94/RC45 panels
- Can be installed anywhere across the width of the bay

PRODUCT NO.	COMBINATION
RC53-2412	Panels only
RC53-241202	Panels and storage cabinets

LAPTOP TRAY



- Supports laptops of up to 14"W x 12"D
- Hooks securely onto RC41/RC42/RC93/RC94/RC45 panels
- Includes a series of bends at the front (¾" surface) that act as a palm rest
- Can be installed anywhere across the width of the bay

PRODUCT NO.
RC54-1412

LCD MONITOR MOUNT



- Supports monitors with a 75mm or 100mm c/c mounting hole pattern (VESA 75 / 100 standard) on RC41/RC42/RC93/RC94/RC45 panels
- Includes a central cutout for cable management from the rear of the mount
- Two positions: vertical or angled 10° forward to reduce reflections

PRODUCT NO.
RC52-20



GT-C1034S



GT-C1069S



5A TOOLBOXES 42-52

- Toolboxes can be ordered on their own or as components of a workcenter as featured on pages 18-31
- 10 drawer heights and 7 toolbox heights available for a wide range of custom combinations
- Drawer lock-in mechanisms available for all models
- Stationary and mobile versions available

5B R2V VERTICAL STORAGE 53-58

- This vertical storage system provides easy access to stored items, increases storage density and reclaims floor space
- Compatible with a wide variety of 5S accessories for simple and efficient inventory management
- Drawer lock-in mechanism included with all models
- Optional One-Drawer-at-a-Time System available
- Installs on standard widths of Rousseau R cabinets
- To ensure unit stability, the unit must be anchored to a cabinet

5C REEL CABINET 61-64

- A range of reel cabinets available that vary according to number of reels required and layout
- Cabinets include a door and/or panel for easy access and maintenance
- Removable drip tray included

5D STORAGE UNIT 65-68

- Unit provides secure storage for technicians' personal belongings and for an oil waste container or MultiTek Cart
- Heights available: 48", 76" and 80". Can be used in a workcenter or as a standalone unit
- To ensure unit stability, the unit must be anchored to a workstation, toolbox, storage cabinet or the wall
- Several configurations available: with or without storage for a MultiTek Cart, L Compact Mobile Cabinet or oil waste container

5E STORAGE UNIT & LOCKER 69-70

- Unit provides secure storage for technicians' personal belongings
- Heights available: 48", 76" and 80". Can be used in a workcenter or as a standalone unit
- To ensure unit stability, the unit must be anchored to a workstation, toolbox, storage cabinet or the wall
- Several configurations possible: 1 door or 2 doors with or without ventilation holes

PRECONFIGURED MODELS - DOUBLE WORKCENTERS

12'W (144"W) WORK SURFACE



GT-C2153S | 12' (144")

Customizing a technician's workcenter has never been easier. Simply follow the steps below to configure your bays.

FOR HELP COMPLETING PRODUCT NUMBERS

7

The complete GT-C2153S unit to the left includes the following products:

- ① GT-W144M1S
 - ② GT-B144B01AC1K1S
 - ③ GT-U144C31S
- ④A GT-M144F2S
 - ⑤C GT-RDG720401S

1 TYPE OF WORK SURFACE

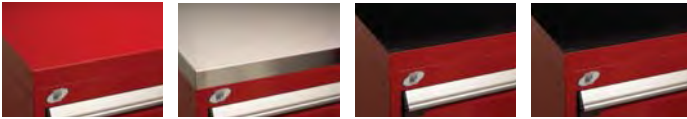

GT-W14400P

GT-W14400S

GT-W144M1_

GT-W144M2_

Our stainless steel and painted steel tops have a particle board core for excellent impact resistance.

- The stainless steel top adds stylish aesthetics
- The rubber mat is oil resistant and protects the work surface (available for painted and stainless steel tops)

2 UNDER THE WORK SURFACE



3 Toolboxes

GT-B144001000X3

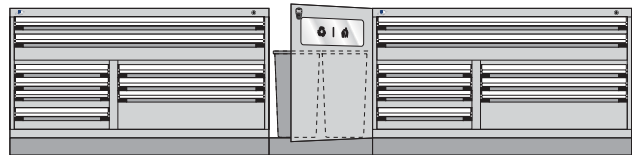

2 Toolboxes - Waste & Recycling Door and Containers

GT-B144B06000K8

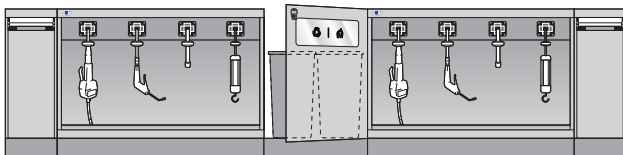

2 Reel Cabinets - Waste & Recycling Door and Containers
2 Lift Control Units

GT-B144A14CR400

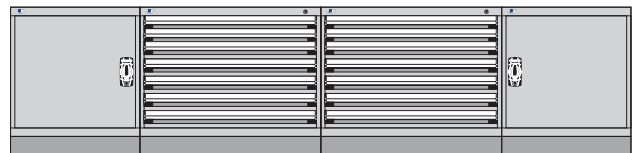

4 Toolboxes

GT-B144001000X2

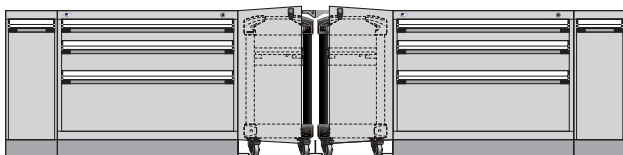

2 Toolboxes - 2 Hideaway Doors - 2 Lift Control Units
2 MultiTek Carts

GT-B144B07AR4A9



2 Toolboxes - 2 Lift Control Units

GT-B144B01AR4K9

PRECONFIGURED MODELS - DOUBLE WORKCENTERS

3 ABOVE THE WORK SURFACE

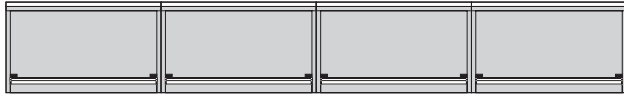

4 Storage Cabinets (wall-mounted)

GT-U14400F



2 Storage Cabinets - 2 Computer Cabinets with Fan (wall-mounted)

GT-U144C_OF

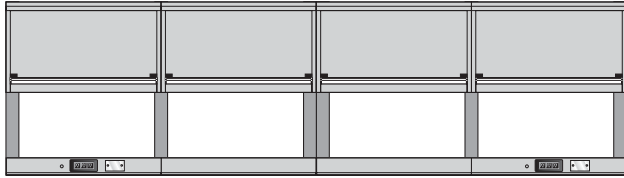

4 Storage Cabinets - Tech Uprights - Panels

GT-U14400_

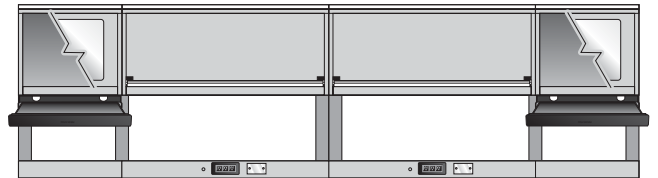

2 Storage Cabinets - 2 Computer Cabinets with Fan - Tech Uprights - Panels

GT-U144C_

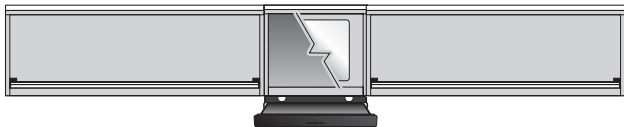

2 Storage Cabinets - Computer Cabinet with Fan (wall-mounted)

GT-U144C_OF

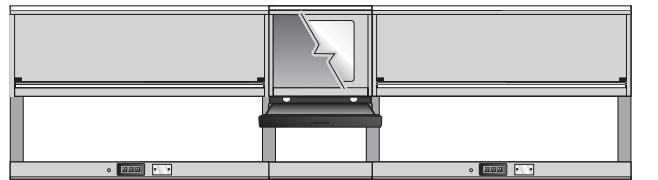

2 Storage Cabinets - Computer Cabinet with Fan - Tech Uprights - Panels

GT-U144C_

4A CENTER - WITH CABINETS



Finishing Panels

GT-M144F1_

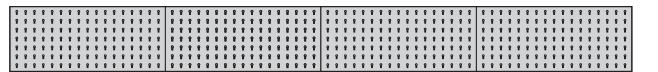

Utility Panels

GT-M144U1_

4B CENTER - WITHOUT CABINETS



Finishing Panels - 19"H Tech Uprights - Panels

GT-M144F119_



Finishing Panels - 40"H Tech Uprights - Panels

GT-M144F140_

4C CENTER - WITHOUT TECH UPRIGHTS



Power Feed Panels

GT-M144T1_



Finishing and Power Feed Panels - LCD Monitor Arms

GT-M144T2_

5A TOOLBOX 42-52

5B VERTICAL STORAGE 53-58

5C REEL CABINET 61-64

5D STORAGE UNIT 65-68

5E STORAGE UNIT AND LOCKER 69-70



Not sure what solution you need? Our specialists will help you find a customized solution for your specific needs. Contact us.

PRECONFIGURED MODELS - DOUBLE WORKCENTERS

10'W (120"W) WORK SURFACE

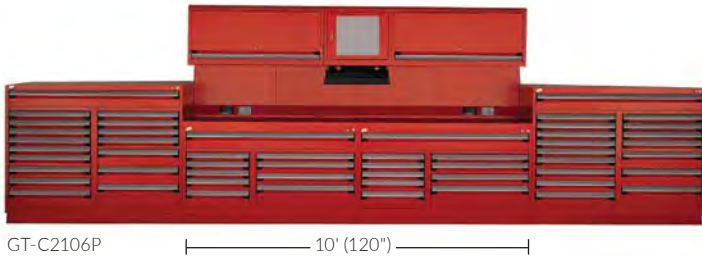

Customizing a technicians workcenter has never been easier. Simply follow the steps below to configure your bays.

FOR HELP COMPLETING PRODUCT NUMBERS



The complete GT-C2106P unit to the left includes the following products:

- ① GT-W120M1P
- ④A GT-M120F1P
- ② GT-B120001000K2P
- ⑤A GT-5KKG44004P (2x)
- ③ GT-U120C11P

1 TYPE OF WORK SURFACE



Our stainless steel and painted steel tops have a particle board core for excellent impact resistance.

- The stainless steel top adds stylish aesthetics
- The rubber mat is oil resistant and protects the work surface (available for painted and stainless steel tops)

2 UNDER THE WORK SURFACE

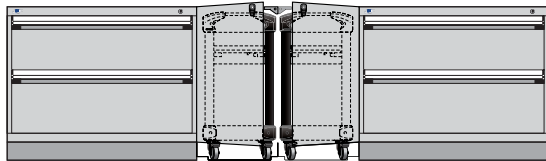

2 Toolboxes - 2 Hideaway Doors - 2 MultiTek Carts

GT-B120001000A8

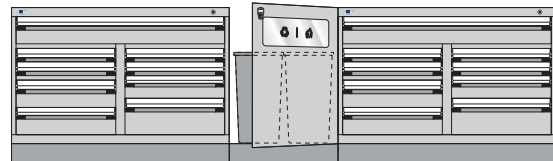

2 Toolboxes - Waste & Recycling Door and Containers

GT-B120B02000K9

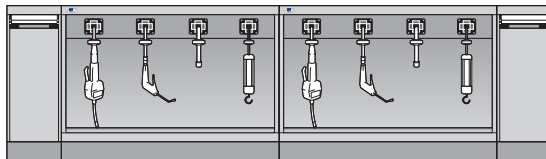

2 Reel Cabinets - 2 Lift Control Units

GT-B120A01CR400

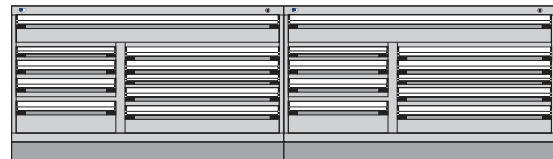

2 Toolboxes

GT-B120001000K2

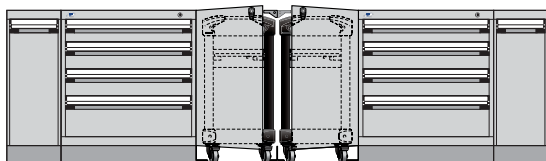

2 Toolboxes - 2 Hideaway Doors - 2 Lift Control Units
2 MultiTek Carts

GT-B120B03AR4C2

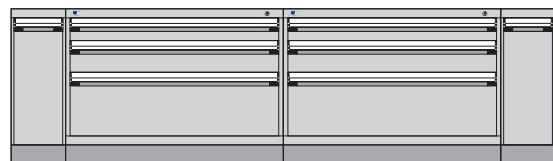

2 Toolboxes - 2 Lift Control Units

GT-B120B01CR4A9

PRECONFIGURED MODELS - DOUBLE WORKCENTERS

3 ABOVE THE WORK SURFACE



2 Storage Cabinets (wall-mounted)

GT-U12001F

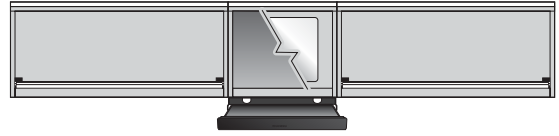

2 Storage Cabinets - Computer Cabinet with Fan (wall-mounted)

GT-U120C_OF

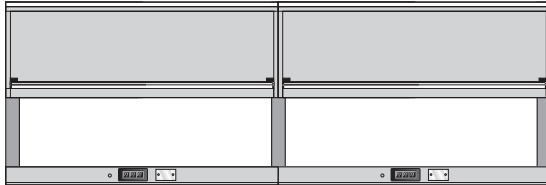

2 Storage Cabinets - Tech Uprights - Panels

Gt-U12001_

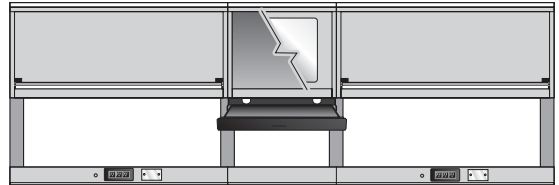

2 Storage Cabinets - Computer Cabinet with Fan - Tech Uprights - Panels

GT-U120C_

4A CENTER - WITH CABINETS



Finishing Panels

GT-M120F1_

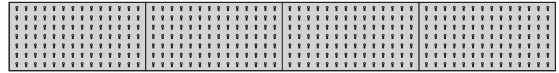

Utility Panels

GT-M120U1_

4B CENTER - WITHOUT CABINETS



Finishing Panels - 19"H Tech Uprights - Panels

GT-M120F119_



Finishing Panels - 40"H Tech Uprights - Panels

GT-M120F140_

4C CENTER - WITHOUT TECH UPRIGHTS



Power Feed Panels

GT-M120T1_



Finishing and Power Feed Panels - LCD Monitor Arms

GT-M120T2_

5A TOOLBOX 42-52

5B VERTICAL STORAGE 53-58

5C REEL CABINET 61-64

5D STORAGE UNIT 65-68

5E STORAGE UNIT AND LOCKER 69-70



GT-C2020P



GT-C2048S



Not sure what solution you need? Our specialists will help you find a customized solution for your specific needs. Contact us.

PRECONFIGURED MODELS - DOUBLE WORKCENTERS

8'W (96"W) WORK SURFACE

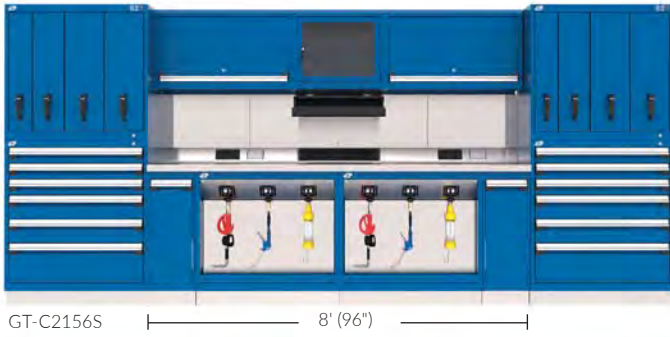

Customizing a technicians workcenter has never been easier. Simply follow the steps below to configure your bays.

FOR HELP COMPLETING PRODUCT NUMBERS:



The complete GT-C2156S unit to the left includes the following products:

- ① GT-W09600S
 - ② GT-B096A03CR400S
 - ③ GT-U096C11S
- ④A GT-M096F1S
 - ⑤B RL-XEG76S002NS (x2)

1 TYPE OF WORK SURFACE



Our stainless steel and painted steel tops have a particle board core for excellent impact resistance.

- The stainless steel top adds stylish aesthetics
- The rubber mat is oil resistant and protects the work surface (available for painted and stainless steel tops)

2 UNDER THE WORK SURFACE

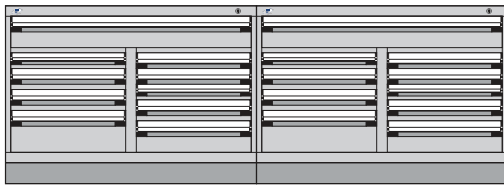

2 Toolboxes

GT-B096001000K2

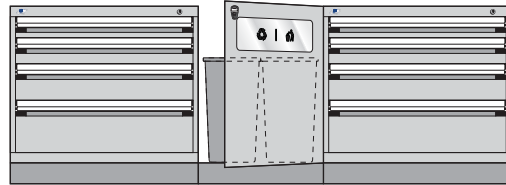

2 Toolboxes - Waste & Recycling Door and Containers

GT-B096B03000A7

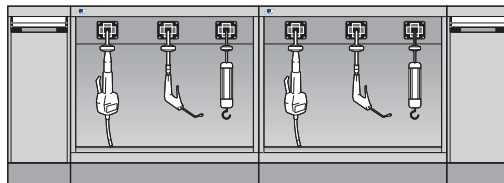

2 Reel Cabinets - 2 Lift Control Units

GT-B096A03CR400



4 Toolboxes

GT-B096001000X1

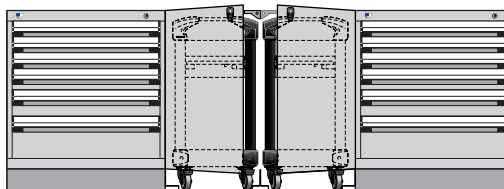

2 Toolboxes - 2 Hideaway Doors - 2 MultiTek Carts

GT-B096B01000A1



2 Toolboxes - 2 Lift Control Units

GT-B096B01AR4A9

PRECONFIGURED MODELS - DOUBLE WORKCENTERS

3 ABOVE THE WORK SURFACE

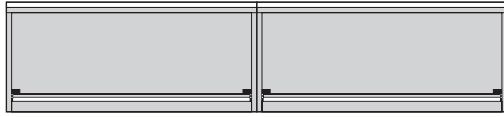

2 Storage Cabinets (wall-mounted)

GT-U09600F

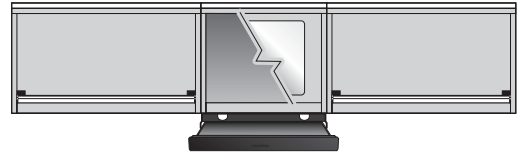

2 Storage Cabinets - Computer Cabinet with Fan (wall-mounted)

GT-U096C_OF

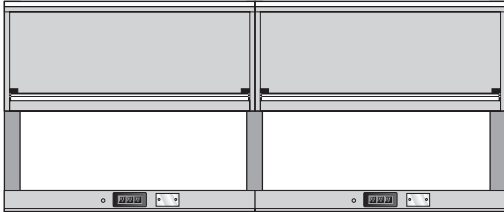

2 Storage Cabinets - Tech Uprights - Panels

GT-U09600

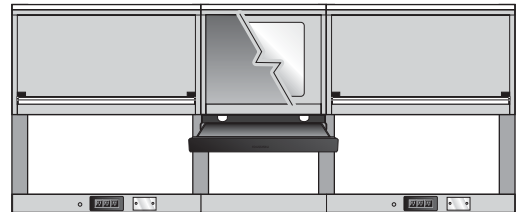

2 Storage Cabinets - Computer Cabinet with Fan Tech Uprights - Panels

GT-U096C

4A CENTER - WITH CABINETS



Finishing Panels

GT-M096F1



Utility Panels

GT-M096U1

4B CENTER - WITHOUT CABINETS

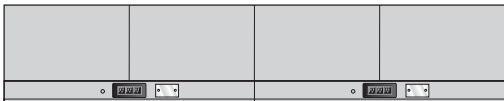

Finishing Panels - 19"H Tech Uprights - Panels

GT-M096F119

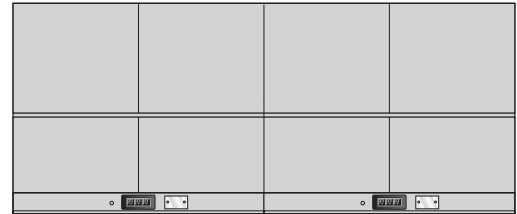

Finishing Panels - 40"H Tech Uprights - Panels

GT-M096F140

4C CENTER - WITHOUT TECH UPRIGHTS



Power Feed Panels

GT-M096T1

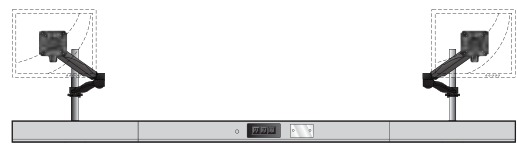

Finishing and Power Feed Panels - LCD Monitor Arms

GT-M096T2

5A TOOLBOX 42-52

5B VERTICAL STORAGE 53-58

5C REEL CABINET 61-64

5D STORAGE UNIT 65-68

5E STORAGE UNIT AND LOCKER 69-70



GT-C2101P



GT-C2036S



Not sure what solution you need? Our specialists will help you find a customized solution for your specific needs. Contact us.

PRECONFIGURED MODELS - DOUBLE WORKCENTERS

7'W (84"W) WORK SURFACE



Customizing a technicians workcenter has never been easier. Simply follow the steps below to configure your bays.

FOR HELP COMPLETING PRODUCT NUMBERS:

7

The complete GT-C2044S unit to the left includes the following products:

- ① GT-W08400S
- ④B GT-M084F1402S
- ② GT-B084001000A8S
- ⑤A GT-5GHG34502PS (2x)

1 TYPE OF WORK SURFACE



Our stainless steel and painted steel tops have a particle board core for excellent impact resistance.

- The stainless steel top adds stylish aesthetics
- The rubber mat is oil resistant and protects the work surface (available for painted and stainless steel tops)

2 UNDER THE WORK SURFACE

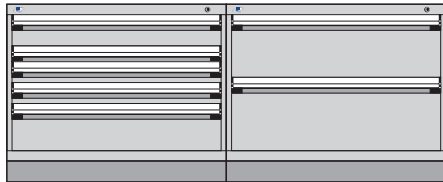

2 Toolboxes

GT-B084001000X2

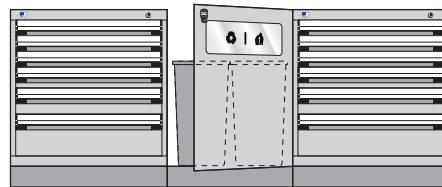

2 Toolboxes - Waste & Recycling Door and Containers

GT-B084B01000A1

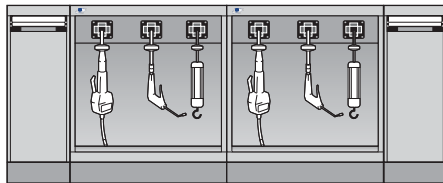

2 Reel Cabinets - 2 Lift Control Units

GT-B084A01CR400

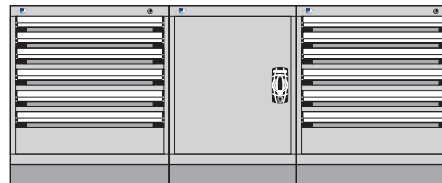

3 Toolboxes

GT-B084001000X1

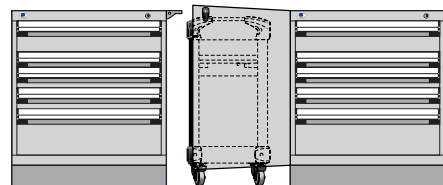

2 Toolboxes - Hideaway Door - MultiTek Cart

GT-B084B02000C3

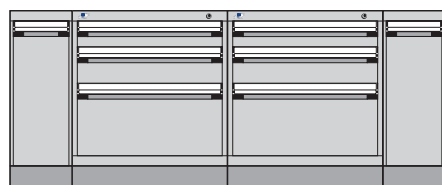

2 Toolboxes - 2 Lift Control Units

GT-B084B01AR4A9

PRECONFIGURED MODELS - DOUBLE WORKCENTERS

3 ABOVE THE WORK SURFACE

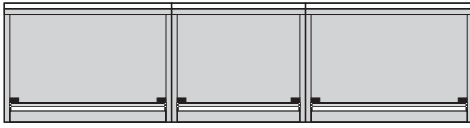

3 Storage Cabinets (wall-mounted)

GT-U08400F

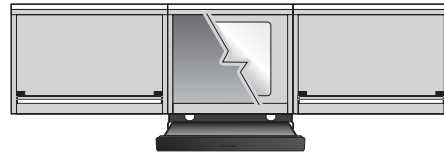

2 Storage Cabinets - Computer Cabinet with Fan (wall-mounted)

GT-U084C_OF

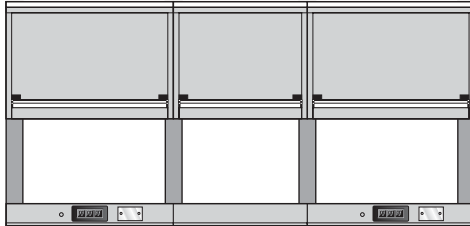

3 Storage Cabinets - Tech Uprights - Panels

GT-U08400_

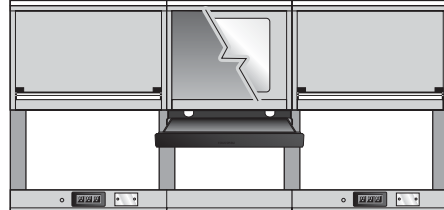

2 Storage Cabinets - Computer Cabinet with Fan
Tech Uprights - Panels

GT-U084C_

4A CENTER - WITH CABINETS



Finishing Panels

GT-M084F1_

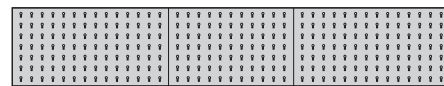

Utility Panels

GT-M084U1_

4B CENTER - WITHOUT CABINETS

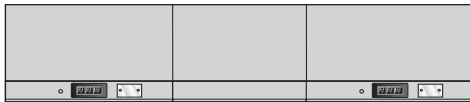

Finishing Panels - 19"H Tech Uprights - Panels

GT-M084F119_

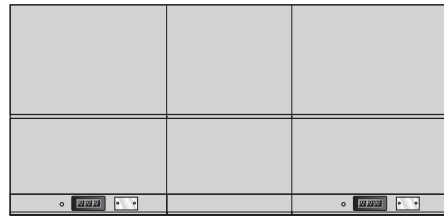

Finishing Panels - 40"H Tech Uprights - Panels

GT-M084F140_

4C CENTER - WITHOUT TECH UPRIGHTS



Power Feed Panels

GT-M084T1_



Finishing and Power Feed Panels - LCD Monitor Arms

GT-M084T2_

5A TOOLBOX 42-52

5B VERTICAL STORAGE 53-58

5C REEL CABINET 61-64

5D STORAGE UNIT 65-68

5E STORAGE UNIT AND LOCKER 69-70



GT-C2139S



GT-C2038S



Not sure what solution you need? Our specialists will help you find a customized solution for your specific needs. Contact us.

PRECONFIGURED MODELS - SINGLE WORKCENTERS

6'W (72"W) WORK SURFACE



6' (72")
GT-C1111S

Customizing a technicians workcenter has never been easier. Simply follow the steps below to configure your bays.

FOR HELP COMPLETING PRODUCT NUMBERS: 7

The complete GT-C1111S unit to the left includes the following products:

- | | |
|--------------------|------------------|
| ① GT-W072M1S | ④A GT-M072F1S |
| ② GT-B072B01AC1K1S | ⑤A GT-5KKG44002S |
| ③ GT-U072C11S | |

1 TYPE OF WORK SURFACE

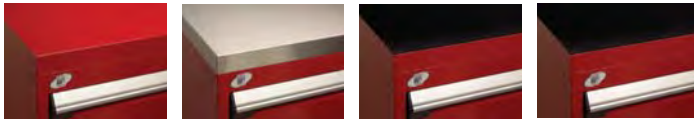

GT-W07200P GT-W07200S GT-W072M1_ GT-W072M2_

Our stainless steel and painted steel tops have a particle board core for excellent impact resistance.

- The stainless steel top adds stylish aesthetics
- The rubber mat is oil resistant and protects the work surface (available for painted and stainless steel tops)

2 UNDER THE WORK SURFACE

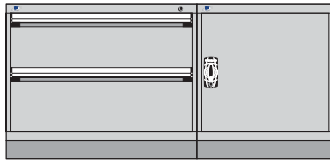

2 Toolboxes
GT-B072001000X1_

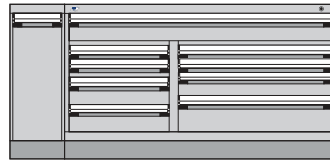

Toolbox - Lift Control Unit
GT-B072B01AR4K9_

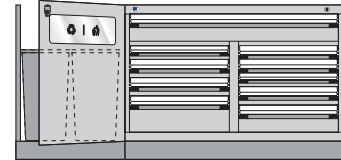

Toolbox - Waste & Recycling Door and Containers
GT-B072B01000K2_

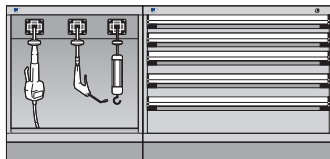

Toolbox - Reel Cabinet
GT-B072A12000A4_

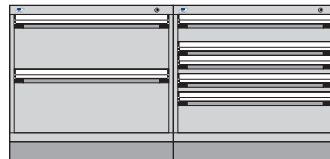

2 Toolboxes
GT-B072001000X3_

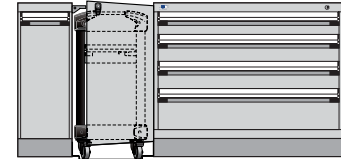

Toolbox - Hideaway Door - Lift Control Unit MultiTek Cart
GT-B072B02AR4C2_

PRECONFIGURED MODELS - SINGLE WORKCENTERS

3 ABOVE THE WORK SURFACE

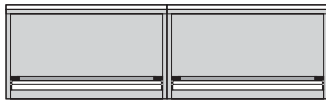

2 Storage Cabinets (wall-mounted)

GT-U07200F

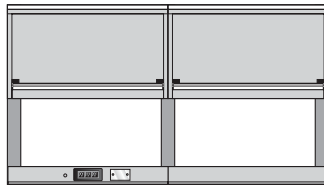

2 Storage Cabinets
Tech Uprights - Panels

GT-U07200

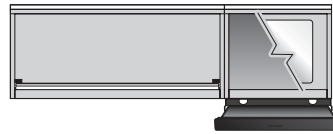

Storage Cabinet - Computer Cabinet
with Fan (wall-mounted)

GT-U072C_0F

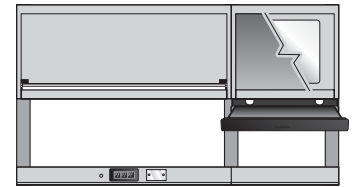

Storage Cabinet - Computer Cabinet
with Fan - Tech Uprights - Panels

GT-U072C_

4A CENTER - WITH CABINETS



Finishing Panels

GT-M072F1

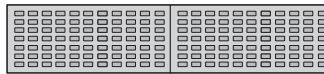

Plastic Bin Panels

GT-M072L1P

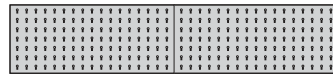

Utility Panels

GT-M072U1

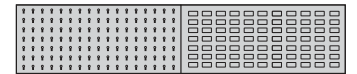

Plastic Bin and Utility Panels

GT-M072X1P

4B CENTER - WITHOUT CABINETS



Finishing Panels
19"H Tech Uprights - Panels

GT-M072F119

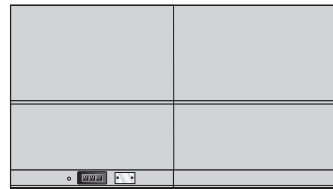

Finishing Panels
40"H Tech Uprights - Panels

GT-M072F140

4C CENTER - WITHOUT TECH UPRIGHTS



Power Feed Panel

GT-M072T1

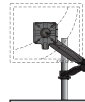

Cover Panel and Power Feed Panel LCD
Monitor Arm

GT-M072T2

5A TOOLBOX 42-52

5B VERTICAL STORAGE 53-58

5C REEL CABINET 61-64

5D STORAGE UNIT 65-68

5E STORAGE UNIT AND LOCKER 69-70



GT-C1103P



GT-C1110P



GT-C1004P



Not sure what solution you need? Our specialists will help you find a customized solution for your specific needs. Contact us.

PRECONFIGURED MODELS - SINGLE WORKCENTERS

5'W (60"W) WORK SURFACE



GT-C1108S | 5' (60")

Customizing a technicians workcenter has never been easier. Simply follow the steps below to configure your bays.

FOR HELP COMPLETING PRODUCT NUMBERS:

7

The complete GT-C1108S unit to the left includes the following products:

- | | |
|--------------------|------------------|
| ① GT-W060M1S | ④A GT-M060F2S |
| ② GT-B060001000K2S | ⑤A GT-5KKG44004S |
| ③ GT-U060C11S | ⑥C GT-REG720601S |

1 TYPE OF WORK SURFACE

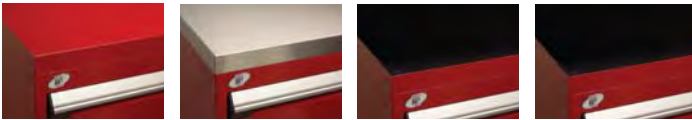

GT-W06000P

GT-W06000S

GT-W060M1_

GT-W060M2_

Our stainless steel and painted steel tops have a particle board core for excellent impact resistance.

- The stainless steel top adds stylish aesthetics
- The rubber mat is oil resistant and protects the work surface (available for painted and stainless steel tops)

2 UNDER THE WORK SURFACE

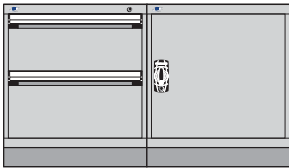

2 Toolboxes

GT-B060001000X1_

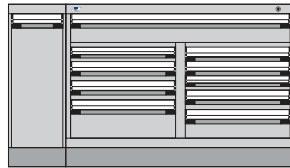

Toolbox - Lift Control Unit

GT-B060B01AR4K2_

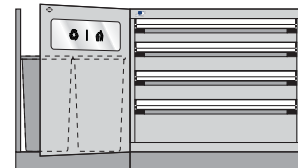

Toolbox - Waste & Recycling Door and Containers

GT-B060B01000C2_

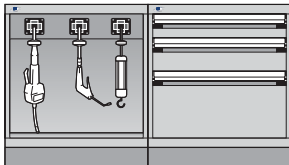

Toolbox - Reel Cabinet

GT-B060A10000A9_

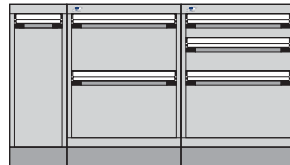

2 Toolboxes - Lift Control Unit

GT-B060B01AR4X1_

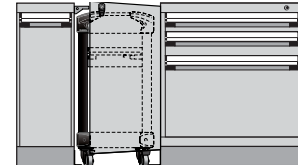

Toolbox - Hideaway Door Lift Control Unit - MultiTek Cart

GT-B060B03AR4C1_

PRECONFIGURED MODELS - SINGLE WORKCENTERS

3 ABOVE THE WORK SURFACE



Storage Cabinet (wall-mounted)
GT-U060010F



Storage Cabinet - Tech Uprights
- Panel
GT-U06001_

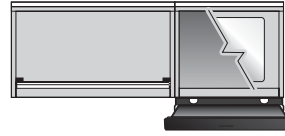

Storage Cabinet - Computer Cabinet
with Fan (wall-mounted)
GT-U060C_0F

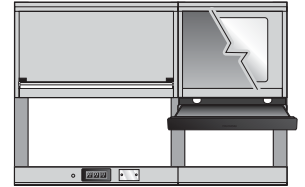

Storage Cabinet - Computer Cabinet
with Fan - Tech Uprights - Panels
GT-U060C_

4A CENTER - WITH CABINETS



Finishing Panels
GT-M060F1_



Finishing Panels
GT-M060F2_

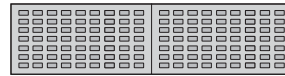

Plastic Bin Panels
GT-M060L1P

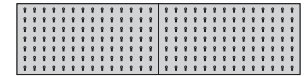

Utility Panels
GT-M060U1_

4B CENTER - WITHOUT CABINETS



Finishing Panels - 19"H Tech Up-
rights - Panels
GT-M060F119_

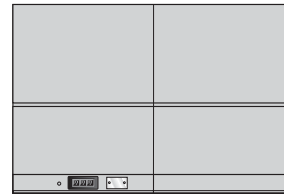

Finishing Panels - 40"H Tech Uprights
- Panels
GT-M060F140_

4C CENTER - WITHOUT TECH UPRIGHTS



Power Feed Panel
GT-M060T1_

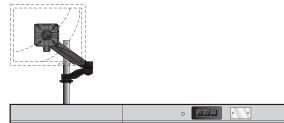

Cover Panel and Power Feed Panel
LCD Monitor Arm
GT-M060T2_

5A TOOLBOX 42-52

5B VERTICAL STORAGE 53-58

5C REEL CABINET 61-64

5D STORAGE UNIT 65-68

5E STORAGE UNIT AND LOCKER 69-70



GT-C1020P



GT-C1163S



GT-C1034S



Not sure what solution you need? Our specialists will help you find a customized solution for your specific needs. Contact us.

PRECONFIGURED MODELS - SINGLE WORKCENTERS

4'W (48"W) WORK SURFACE



Customizing a technicians workcenter has never been easier. Simply follow the steps below to configure your bays.

FOR HELP COMPLETING PRODUCT NUMBERS:



The complete GT-C1053S unit to the left includes the following products:

- ① GT-W04800S
- ④A GT-M048F1S
- ② GT-B048B04000A7S
- ⑤A GT-5ADG44506S
- ③ GT-U048000S

1 TYPE OF WORK SURFACE



Our stainless steel and painted steel tops have a particle board core for excellent impact resistance.

- The stainless steel top adds stylish aesthetics
- The rubber mat is oil resistant and protects the work surface (available for painted and stainless steel tops)

2 UNDER THE WORK SURFACE

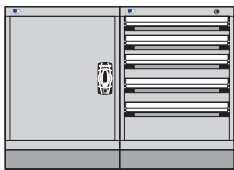

2 Toolboxes
GT-B048001000X3_

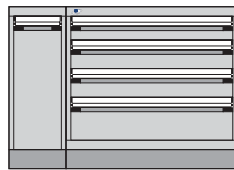

Toolbox - Lift Control Unit
GT-B048B01AR4C2_

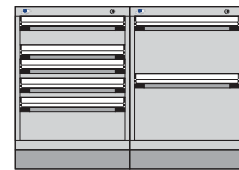

2 Toolboxes
GT-B048001000X4_

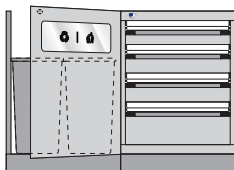

Toolbox - Waste & Recycling Door and Containers
GT-B048B03000C2_

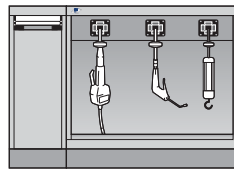

Reel Cabinet - Lift Control Unit
GT-B048A03CR400_

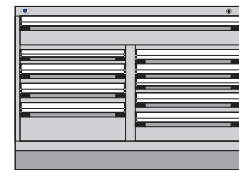

Toolbox
GT-B048001000K2_

PRECONFIGURED MODELS - SINGLE WORKCENTERS

3 ABOVE THE WORK SURFACE



Storage Cabinet (wall-mounted)
GT-U04800F



Storage Cabinet - Tech Uprights - Panel
GT-U04800

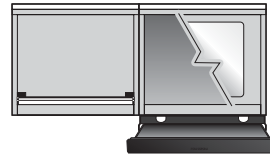

Storage Cabinet - Computer Cabinet with Fan (wall-mounted)
GT-U048C_OF

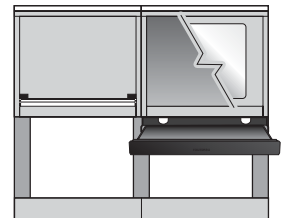

Storage Cabinet - Computer Cabinet with Fan - Tech Uprights - Panels
GT-U048C_O_

4A CENTER - WITH CABINETS



Finishing Panels
GT-M048F1

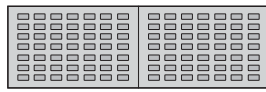

Plastic Bin Panels
GT-M048L1P

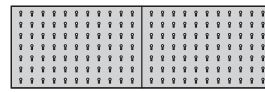

Utility Panels
GT-M048U1

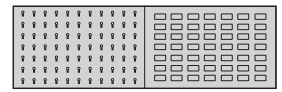

Plastic Bin and Utility Panels
GT-M048X1P

4B CENTER - WITHOUT CABINETS



Finishing Panels - 19\"/>

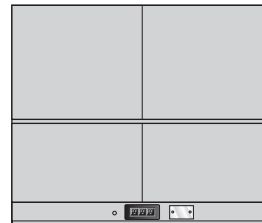

Finishing Panels - 40\"/>

4C CENTER - WITHOUT TECH UPRIGHTS



Power Feed Panel
GT-M048T1

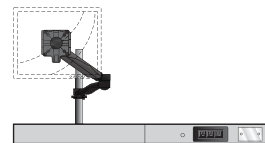

Cover Panel and Power Feed Panel LCD Monitor Arm
GT-M048T2

5A TOOLBOX 42-52

5B VERTICAL STORAGE 53-58

5C REEL CABINET 61-64

5D STORAGE UNIT 65-68

5E STORAGE UNIT AND LOCKER 69-70



GT-C1044S



GT-C1142S



GT-C1101P



Not sure what solution you need? Our specialists will help you find a customized solution for your specific needs. Contact us.

CORNER WORKSTATIONS

MAXIMIZE SPACE FOR WORK AND STORAGE



Ferrari Lake Forest (IL)

Corner workstations allow for a more complete and integrated layout. They also make use of all available space for work and storage.

- Ergonomic 36" or 40" work surface height
- Standard 30" work surface depth
- Choice of two configurations: with or without cabinet under the work surface
- Leveling glides included in each model for a stable and level workstation
- Designed to be placed against a wall or back to back
- Must be anchored to two cabinets of the same height and depth, one on each side (RA30 or RA35)

To order, choose "WITH" or "WITHOUT" cabinet under the work surface. Then configure your workstation. Options vary depending on the configuration chosen.

WITHOUT CABINET UNDER THE WORK SURFACE

WITH CABINET UNDER THE WORK SURFACE

0030
RIGHT-ANGLED CORNER
(2"W FINISHING PANEL)



RS-C084X

0630
9"W FINISHING PANEL



RS-C002X

1230
L CABINET



RS-C080S

1830
R CABINET



RS-C008X

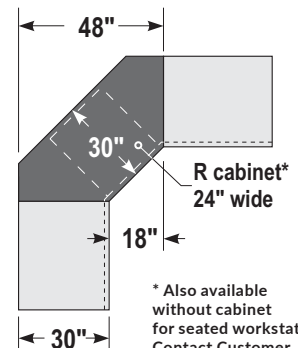
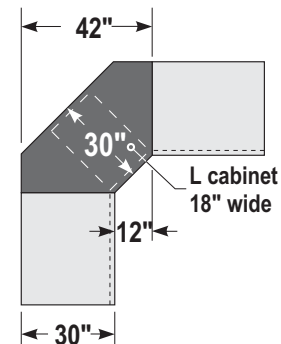
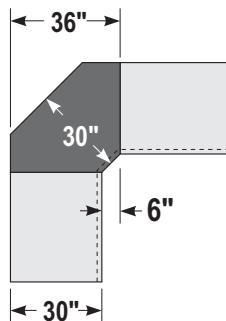
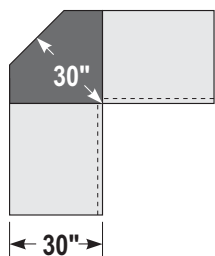

* Also available without cabinet for seated workstations. Contact Customer Service.

CORNER WORKSTATIONS - 0030



RS-J00303404X

1 TYPE OF WORK SURFACE

Choose your work surface.

For a neoprene or nitrile rubber mat, choose the desired finish: painted steel (P) or stainless steel (S).



Painted steel

RS-W003001P



Stainless steel

RS-W003001S



Nitrile mat - 3/16"

RS-W0030M3_



Neoprene mat - 1/8"

RS-W0030M4_

2 UNDER THE WORK SURFACE

Choose your workstation height and a finish for the base.

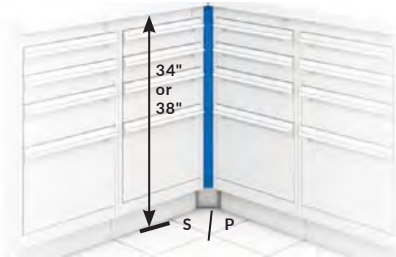

34" high: 34*
38" high: 38*
Base:
Painted steel: P
Stainless steel: S

RS-B0030__1001_

e.g., RS-B0030341001S for a 34"H 0030 corner workstation with stainless steel base.
* Includes the 4"H base but excludes the 2"H top

3 ABOVE THE WORK SURFACE

Choose from the following models.

Choose the finish for the power feed panel or cover panel: painted steel (P) or stainless steel (S).

A

Upper finishing panels + power feed panel*
RS-U0030F14_

For this model, the power feed panel determines the panel finish, P or S.

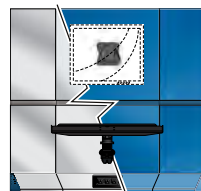

Finishing panels + LCD monitor arm and keyboard & mouse tray + power feed panel*

RS-M0030S1404_

For this model, the power feed panel determines the panel finish, P or S.

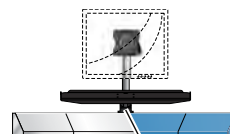

Cover panel + LCD monitor arm and keyboard & mouse tray

RS-M0030T3_



Power feed panel*

RS-M0030T4_

NOTE: * Includes three 12A power outlets

4 CENTER - BOTTOM PANELS

Choose the panels required for model A.

Choose the panel finish: painted steel (P) or stainless steel (S).



Finishing panels

RS-M0030F1_



Utility panels

RS-M0030U1_

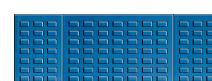

Plastic bin panels

RS-M0030L1P



Finishing panels
Tablet arm

RS-M0030S2_

CORNER WORKSTATIONS - 0630



RS-J06303404P

1 TYPE OF WORK SURFACE

Choose your work surface

For a neoprene or nitrile rubber mat, choose the desired finish: painted steel (P) or stainless steel (S).



Painted steel
RS-W063001P



Stainless steel
RS-W063001S



Nitrile mat - 3/16"
RS-W0630M3



Neoprene mat - 1/8"
RS-W0630M4

2 UNDER THE WORK SURFACE

Choose your workstation height and a finish for the base.

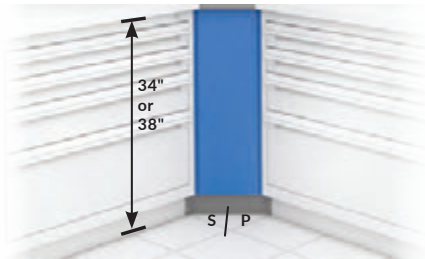

34" high: 34*
38" high: 38*
Base:
Painted steel: P
Stainless steel: S

RS-B0630__1001_

e.g., RS-B0630341001S for a 34"H 0630 corner workstation with stainless steel base.
* Includes the 4"H base but excludes the 2"H top.

3 ABOVE THE WORK SURFACE

Choose from the following models.

Choose the finish for the power feed panel or cover panel: painted steel (P) or stainless steel (S).

A

Storage cabinet with flipper door + power feed panel²
RS-U0630R01_

B

Computer cabinet + cover panel
RS-U0630C10_

C

Upper finishing panels + power feed panel¹
RS-U0630F11_

For this model, the power feed panel determines the panel finish, P or S.



Finishing panels + LCD monitor arm and keyboard & mouse tray + power feed panel^{1 2}
RS-M0630S1401_

In this model the power feed panel determines the panel finish, P or S.

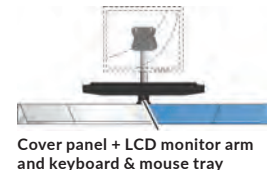

Cover panel + LCD monitor arm and keyboard & mouse tray
RS-M0630T3_



Power feed panel²
RS-M0630T1_

NOTES: ¹The computer mount is positioned on the right by default in this model.

²Includes three 12A power outlets, a knockout for a pneumatic connection and a perforation for installing a telephone or Ethernet jack.

4 CENTER - LOWER PANELS

Choose the panels required for models

A, B and C.

Choose the panel finish: painted steel (P) or stainless steel (S).



Finishing panels
RS-M0630F1_



Utility panels
RS-M0630U1_

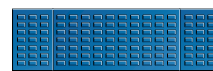

Plastic bin panels
RS-M0630L1P



Finishing panels
Tablet arm
RS-M0630S2_

The computer mount is positioned on the right by default in this model.

CORNER WORKSTATIONS - 1230



RS-J12303402X

1 TYPE OF WORK SURFACE

Choose your work surface

For a neoprene or nitrile rubber mat, choose the desired finish: painted steel (P) or stainless steel (S).



Painted steel
RS-W123001P



Stainless steel
RS-W123001S

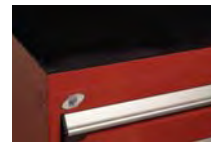

Nitrile mat - 3/16"
RS-W1230M3

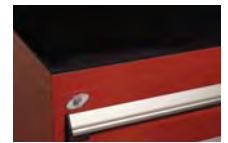

Neoprene mat - 1/8"
RS-W1230M4

2 UNDER THE WORK SURFACE

Choose your workstation and cabinet height and a finish for the base.

Cabinet models include a central locking system (L3), attachments bars under the surface and finishing panels. Cabinet dimensions are 18"W x 27"D x 34"H/38"H.

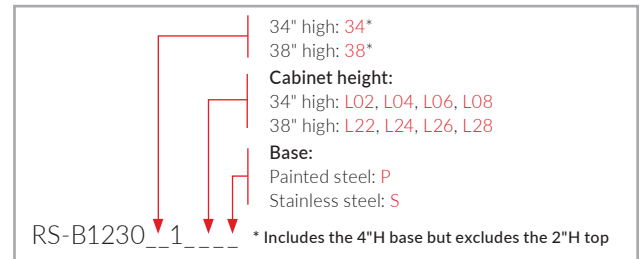

34"H CABINETS



38"H CABINETS



3 ABOVE THE WORK SURFACE

Choose from the following models. Choose the finish for the power feed panel or cover panel: painted steel (P) or stainless steel (S).

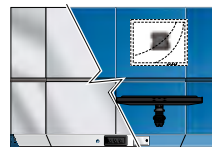
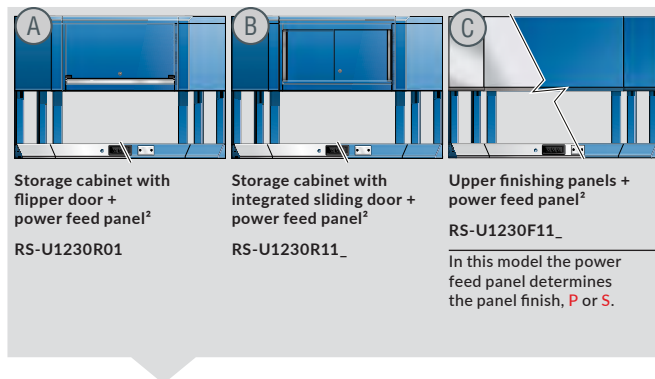

Finishing panels + LCD monitor arm and keyboard & mouse tray¹ + power feed panel²
RS-M1230S1401_

In this model the power feed panel determines the panel finish, P or S.



Cover panel + LCD monitor arm and keyboard & mouse tray
RS-M1230T3_



Power feed panel²
RS-M1230T1_

NOTES: ¹The computer mount is positioned on the right by default in this model.

²Includes three 12A power outlets, a knockout for a pneumatic connection and a perforation for installing a telephone or Ethernet jack.

4 CENTER - LOWER PANELS

Choose the panels required for models

A, B and C.

Choose the panel finish:

painted steel (P) or stainless steel (S).



Finishing panels
RS-M1230F1_



Utility panels
RS-M1230U1_

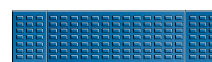

Plastic bin panels
RS-M1230L1P



Finishing panels - Tablet arm
RS-M1230S2_

The computer mount is positioned on the right by default in this model.

CORNER WORKSTATIONS - 1830

1 TYPE OF WORK SURFACE

Choose your work surface

For a neoprene or nitrile rubber mat, choose the desired finish: painted steel (P) or stainless steel (S).



Painted steel

RS-W183001P



Stainless steel

RS-W183001S

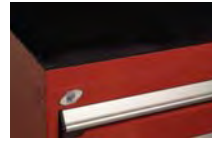

Nitrile mat - 3/16"

RS-W1830M3



Neoprene mat - 1/8"

RS-W1830M4



RS-J18303402X

2 UNDER THE WORK SURFACE

Choose your workstation and cabinet height and a finish for the base.

Cabinet models include a central locking system (L3), attachments bars under the surface and finishing panels. Cabinet dimensions are 24"W x 27"D x 34"H/38"H.

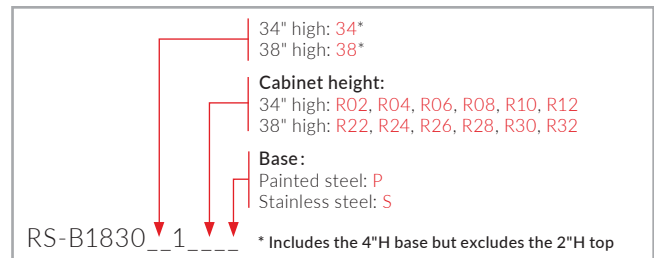

34"H CABINETS



R01
R5ACG-3029S



R03
R5ACG-3031S



R06
R5ACG-3034S



R07
R5ACG-3035S



R09
R5ACG-3037S



R11
R5ACG-3039S
With waste and recycling drawer

38"H CABINETS



R21
R5ACG-3407S



R23
R5ACG-3409S



R26
R5ACG-3412S



R27
R5ACG-3413S



R29
R5ACG-3415S



R31
R5ACG-3417S
With waste and recycling drawer

3 ABOVE THE WORK SURFACE

Choose from the following models. Choose the finish for the power feed panel or cover panel: painted steel (P) or stainless steel (S).

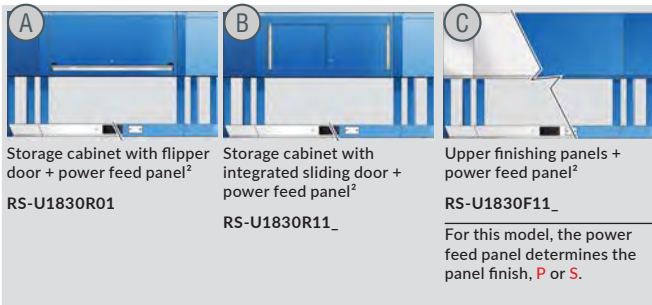

In this model the power feed panel determines the panel finish, P or S.

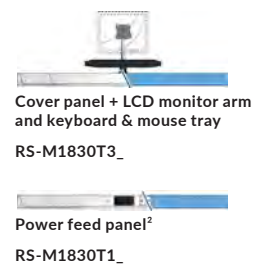

NOTE: For notes 1 & 2, please see page 35.

4 CENTER - LOWER PANELS

Choose the panels required for models A, B and C.

Choose the panel finish: painted steel (P) or stainless steel (S).

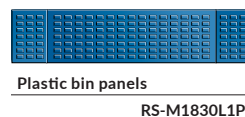
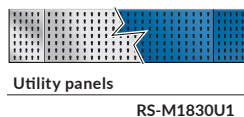

The computer mount is positioned on the right by default in this model.

LED LIGHT



- Brighter and more energy efficient than a fluorescent tube
- Brightens shaded areas under cabinets
- Color temperature: 6000-7000K (cool)
- Includes a galvanized steel fitting
- Includes a 10' power cord
- The recommended operating temperature for our LED lights is between 5 and 40 °C (41 to 104 °F)
- An optional motion sensor can be added

PRODUCT NO.	CONFIGURATION
RD45-2416__	0630 and 1230
RD45-3616__	1830

NOTES: To order an LED light with motion sensor, add **MS** to the product number.
Not compatible with computer cabinets.

MULTI-PURPOSE HOLDER



- Holds up to four aerosol cans
- Also compatible with drinks cans

PRODUCT NO.	FOR
RC51-120312	With or without top cabinet
RC51-120303	With panel configurations only

TOOL HOLDERS



- Variety of hooks and holders available for hanging items and tools. Here are our most popular products:

PRODUCT NO.	FOR
WM9N-01	Single Screwdriver Holder
WM9H-05	Double Back Single Hook
WM9M-01	Pliers Holder
WM9G-200	2" dia. Single Loop Hook

MULTI-PURPOSE SUPPORT

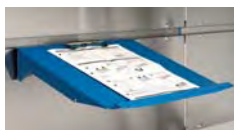

- Includes a clip to keep documents in place

PRODUCT NO.	FOR
RC54-141202	With or without top cabinet
RC54-1412	With panel configurations only

SLOPED TOP



- Keeps the workspace clean and safe while reducing clutter
- The top for computer cabinets includes a fan

PRODUCT NO.	CONFIGURATION	FOR
RS31-063008	0630	Storage cabinet
RS31-123008	1230	Storage cabinet
RS31-183008	1830	Storage cabinet
RS32-063008	0630	Computer cabinet

TABLET ARM



- Compatible with most tablets on the market
- Installs on a lower (15") finishing panel for computer arm (RS81/RS82)
- Compatible tablet sizes:
 - Small: 7 $\frac{1}{8}$ "W to 10"W
 - Large: 9 $\frac{1}{8}$ "W to 12 $\frac{1}{4}$ "W

PRODUCT NO.	FOR
RC58-62-01	Small
RC58-62-02	Large



RS-C010X



RS-C006X



RS-C060X

TEKZONE WORKSTATION HUTCH

SECURITY – FLEXIBILITY – EFFICIENCY



With the TekZone Workstation Hutch, you can create a personalized and organized workspace.

- The work area it provides is spacious and well lit. Each TekZone Hutch is equipped with an LED light with motion sensor so the workspace lights up as soon as you open the door
- A wide range of accessories helps you to stay tidy by freeing up the work surface, while keeping your essential tools close at hand
- The ingenious door mechanism allows you to open and close the hutch easily, smoothly and safely. With the full-width handle, you can open the door with any hand position. The door is fitted with a lock to secure the contents of the hutch



4 EASY STEPS

In just four steps, we can help you configure your own layout quickly and easily.

OPEN/CLOSED VIEW



TZ-C044S



TEKZONE WORKSTATION HUTCH

1 DIMENSIONS AND PANEL TYPES

Utility panels

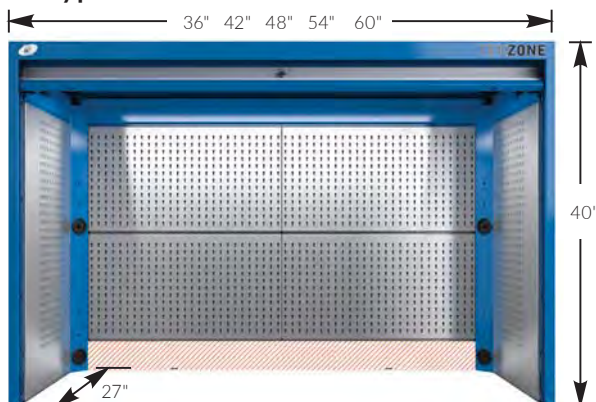

Plastic bin panels and utility panels

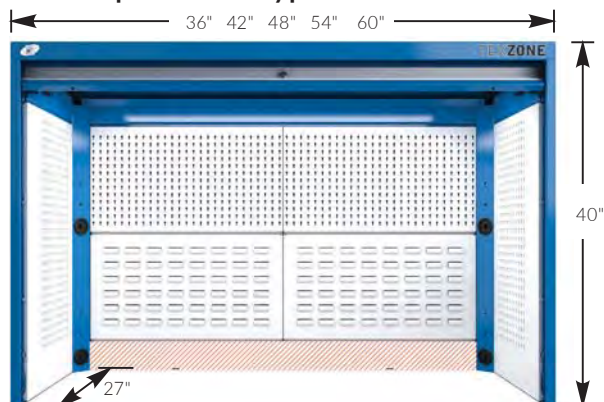

Width: 36" = E ; 42" = G ; 48" = H ; 54" = J ; 60" = K
 Painted steel: P
 Stainless steel: S

TZ-U_G40U002_L3 Specify the width required and the panel finish: painted steel (P) or stainless steel (S).

Width: 36" = E ; 42" = G ; 48" = H ; 54" = J ; 60" = K
 Painted steel: P

TZ-U_G40X002PL3 Specify the width required.

2 POWER FEED PANELS AND COVER PANELS

3 Power Outlets (12A)
 TZ-M0__T4_

3 Power Outlets (12A), Knockout and Perforation
 TZ-M0__T1_

3 Power Outlets (12A), 2 USB Ports
 TZ-M0__T2_

3 Power Outlets (12A), 2 USB Ports, Knockout and Perforation
 TZ-M0__T3_

Width: 36", 42", 48", 54" and 60"
 Painted steel: P Stainless steel: S

TZ-M0__T4_ Specify the width required and the panel finish: painted steel (P) or stainless steel (S).

Cover Panel
 TZ-M0__00_

3 TOPS

Slim Painted Steel Top
 RH10_-_27 For R cabinets

Slim Stainless Steel Top
 RH11_-_27 For R cabinets

1 3/8" Painted Steel Top
 RC37-___-02 For R cabinets or GT workstations

1 3/8" Stainless Steel Top
 RC35-___-02 For R cabinets or GT workstations

Resistant Rubber Mat (Top must be ordered separately)
 RH90-___ 3/16" oil-resistant nitrile
 RH91-___ 1/8" neoprene

Widths: 36", 42", 48", 54" and 60"
 Depths: 27" and 30"

e.g., RH90-60 27 Specify the width and depth required.

TEKZONE WORKSTATION HUTCH

4 ACCESSORIES

TABLET ARM

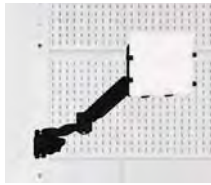

- Compatible with most tablets on the market
- The clamps and mount have a non-slip surface to keep the tablet stable
- Includes an articulating arm with two joints
- The articulating arm with two joints provides extra adjustment options
- Tablet can be rotated and tilted
- Compatible tablet sizes:
 - Small: 7 $\frac{5}{8}$ "W to 10"W
 - Large: 9 $\frac{7}{8}$ "W to 12 $\frac{1}{4}$ "W

PRODUCT NO.	FOR
WM06-62-01	Small
WM06-62-02	Large

LCD MONITOR MOUNT AND KEYBOARD & MOUSE ARM



- Holds a computer monitor, keyboard and mouse
- Keyboard tray's usable area: 23 $\frac{3}{8}$ "W x 8 $\frac{1}{2}$ "D
- Includes an articulating arm with a single joint and an articulating arm with two joints
- The articulating arm with two joints provides extra adjustment options
- Compatible with most LCD monitors (max. 21") on the market
- Complies with VESA 75 and 100 monitor mounting standards
- Monitor and tray can be rotated and tilted

PRODUCT NO.	USE
WM06-22	Kit
WM06-02	Articulating arm for monitor
WM06-32	Articulated arm for keyboard and mouse

LAPTOP ARM



- Holds a laptop, electronic device or any other object
- Tray's usable area: 14"W x 12"D
- Includes an articulating arm with two joints
- The articulating arm with two joints provides extra adjustment options
- Tray can be rotated and tilted

PRODUCT NO.
WM06-42

LCD MONITOR MOUNT



- Supports a monitor compliant with the VESA 75 and 100 standards
- Includes a central cutout for cable management from the rear of the mount
- Two positions: vertical or angled 10° forward to reduce reflections

PRODUCT NO.
RH52-15

LED WORK LAMP WITH MAGNIFIER



- Diopter: 5 (2.25 × magnification)
- Requires an RH50 Lamp Adapter

PRODUCT NO.	USE
RH50-01	Lamp adapter
70000640	LED work lamp with magnifier

KEYBOARD TRAY



- Hooks onto back utility panels at the desired height
- Unique and heavy-duty design with palm rests
- 25"W to accommodate a keyboard and mouse
- Includes a non-slip protective mat

PRODUCT NO.
RH53-25

WIRE SPOOL AND ROLL HOLDERS



- Hooks onto utility panels at the desired height
- Ideal for wire spools or paper towel rolls
- Tube diameter: $\frac{3}{4}$ "
- Load capacity: 50lb.

PRODUCT NO.	WIDTH	USE
WM9P-1201	12"	for 27"D side panels
WM9P-2001	20"	for half-width back panels on a 48"W hutch
WM9P-2301	23"	for half-width back panels on a 54"W hutch
WM9P-2601	26"	for half-width back panels on a 60"W hutch for back panels on a 36"W and 42"W hutch

PLASTIC BIN RAIL



- Hooks onto utility panels at the desired height
- Plastic bins hook onto the rail for efficient storage of small parts
- Compatible with RG20 plastic bins (sold separately)

PRODUCT NO.	WIDTH	USE
WM9C-12	12"	for 27"D side panels
WM9C-20	20"	for half-width back panels on a 48"W hutch
WM9C-23	23"	for half-width back panels on a 54"W hutch
WM9C-26	26"	for half-width back panels on a 60"W hutch for back panels on a 36"W and 42"W hutch

TEKZONE WORKSTATION HUTCH

SLOPED TOP



- Keeps the workspace clean and safe while reducing clutter
- Height: 8"

PRODUCT NO.	W × D
RH89-362708	36" × 27"
RH89-422708	42" × 27"
RH89-482708	48" × 27"
RH89-542708	54" × 27"
RH89-602708	60" × 27"

CAN HOLDER



- Hooks onto utility panels at the desired height
- Ideal for storing cans and other containers of different sizes
- Compatible with side and back panels
- Depth x height: 3" x 4"

PRODUCT NO.	WIDTH
WM9D-12	12"

SHELF AND DIVIDERS



- Hooks onto back utility panels at the desired height
- Can be installed at a right angle or angled 15°
- The shelf is reversible and its edge can act as a back stop for plastic bins and ring binders
- Load capacity: 100lb. (evenly distributed)
- Compatible with SH52-1206 dividers in 2" increments c/c
- Width compatibility:
 - 36" and 42" hutches: full-width shelf
 - 48", 54" and 60" hutches: half-width shelf

PRODUCT NO.	WIDTH	COMPATIBILITY
RH60-24__	20"	½ shelf for 48"W hutch
RH60-27__	23"	½ shelf for 54"W hutch
RH60-30__	26"	½ shelf for 60"W hutch
RH61-36__	29"	Shelf for 36"W hutch
RH61-42__	35"	Shelf for 42"W hutch
SH52-1206		Divider

NOTE: Add 08 to the product number for an 8"D shelf and 12 for a 12"D shelf.

MIDDLE SHELF AND BOTTOM SHELF

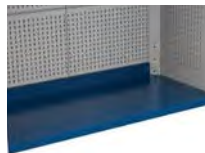
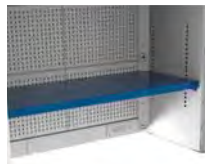

- Full-length and full-depth shelf
- Load capacity: 200lb. (evenly distributed)
- Compatible with SH52-2106 dividers in 3" increments c/c
- Compatible with RH20 and RH21 back utility panels (the panel area right next to the shelf will be unusable)
- Not compatible with RH22/RH23 back plastic bin panels

RH64 Middle Shelf:

- Attaches to RH35 side panels only
- To add to a preconfigured TZ model, replace the side panels with RH35 side panels
- Not compatible with the following side panels: RH32 plastic bin panels, RH30/RH31 utility panels and RH28/RH29 finishing panels

RH65 Bottom Shelf:

- A top (page 39) is required for joining the hutch to the cabinet underneath

PRODUCT NO.	WIDTH	ACTUAL DEPTH
RH_-3627	36"	20 7/16"
RH_-4227	42"	20 7/16"
RH_-4827	48"	20 7/16"
RH_-5457	54"	20 7/16"
RH_-6027	60"	20 7/16"

NOTES: Add 64 to the product number for a middle shelf and 65 for a bottom shelf. RH40/41 power feed panels, RH38/39 cover panels and RH36/37 cable management modules cannot be used with the bottom shelf.

BATTERY CHARGER SHELF



- Hooks onto back utility panels at the desired height
- 25" usable width accommodates several chargers at once
- Includes a non-slip protective mat
- Includes a built-in power strip with six power outlets (15A/120V, with switch, circuit breaker and 15' power cord)
- Includes storage space for cable management

PRODUCT NO.	WIDTH
RH54-26	26"

TEKZONE: KEEPING YOUR WORKSPACE ORGANIZED AND YOUR TOOLS SECURE



TOOLBOXES

QUALITY - DURABILITY - VERSATILITY



Richmond Hill Toyota (ON)

Forget everything you think you know about toolboxes because Rousseau toolboxes are in a different league. Those who try them never look back! You will love their distinctive looks and impressive versatility. Whether you need just one unit or one hundred, our specialists will help you build your ideal configuration.

ROUSSEAU: A VAST RANGE OF SOLUTIONS

- Many different dimensions available
- Different work surface options
- A choice of 20 standard colors
- Duotone available
- A wide variety of accessories
- An L3 standard lock is included on all preconfigured toolbox models. For an L50 electronic lock, contact Customer Service

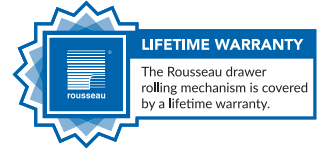

ROUSSEAU TOOLBOXES ARE DESIGNED, DEVELOPED AND MANUFACTURED IN NORTH AMERICA

Choose one of our preconfigured models or build your own.

UNDER THE WORK SURFACE



SIDE



MOBILE

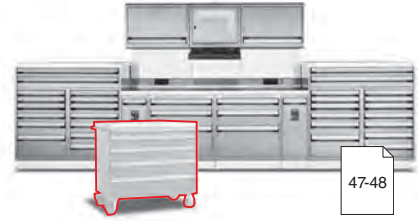

TOOLBOX ACCESSORIES

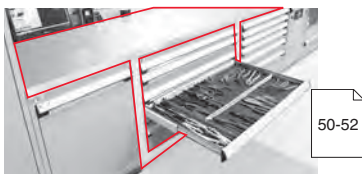

DRAWER ACCESSORIES

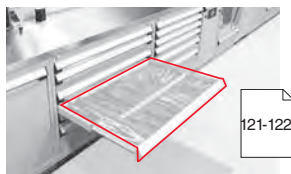

2 UNDER THE WORK SURFACE



Toolboxes can be ordered on their own or as components of ² workcenters ("Under the Work Surface") as featured on pages 18-31.

- Multi-drawer cabinets include stabilizing bars to provide extra rigidity to the housing
- An L3 standard lock is included on all preconfigured toolbox models. For an L50 electronic lock, contact Customer Service
- A range of optional accessories are also available



SOME OF OUR MOST POPULAR MODELS ARE SHOWN BELOW:

Widths: 1 bank of drawers: 24" (C); 30" (D); 36" (E); 42" (G); 48" (H); 54" (J); 60" (K);
 3 banks of drawers: 48" (H); 54" (J); 60" (K);
 4 banks of drawers: 72" (L); 84" (U); 96" (R);

Depth: 27"

Heights: 34", 38" (including the 4"H base)

NOTE	WIDTH
1	Available in 48"W, 54"W and 60"W
2	H (48"W) 1 bank 48"W, 2 banks 24"W
	J (54"W) 1 bank 54"W, 1 bank 24"W, 1 bank 30"W
	K (60"W) 1 bank 60"W, 2 banks 30"W
3	H (48"W) 1 bank 48"W, 2 banks 24"W
	J (54"W) 1 bank 54"W, 1 bank 18"W, 1 bank 36"W
	K (60"W) 1 bank 60"W, 1 bank 24"W, 1 bank 36"W
4	24"W single integrated swing door
	30"W+ double integrated swing doors
5	Only available in 24"W and 30"W

NOTE: The 18"W and 24"W banks of drawers are always installed on the left side of a 54"W and 60"W housing.

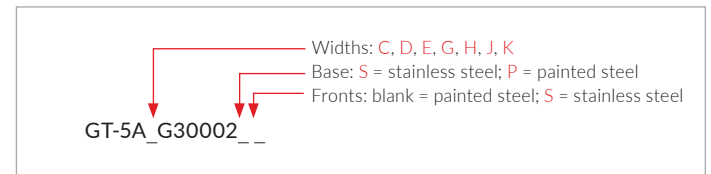

34"H



TOOLBOXES

2 UNDER THE WORK SURFACE

34"H



3 Drawers

GT-5A_G30044_



2 Drawers - 1 Waste & Recycling Drawer

GT-5A_G30046_ (Note 5)

See page 10 for more details on the Waste & Recycling Drawer.



4 Drawers

GT-5A_G30048_



Integrated Swing Doors - 2 Shelves

GT-5A_G30012_ (Note 4)



Integrated Sliding Doors - 2 Shelves

GT-5A_G30014_ (Note 1)



11 Drawers

GT-5K_G30002_ (Note 2)



10 Drawers

GT-5K_G30004_ (Note 3)



7 Drawers

GT-5K_G30010_ (Note 2)



7 Drawers

GT-5K_G30008_ (Note 2)



7 Drawers

GT-5K_G30016_ (Note 2)



9 Drawers

GT-5K_G30018_ (Note 3)



9 Drawers

GT-5K_G30020_ (Note 3)



9 Drawers

GT-5K_G30024_ (Note 2)



11 Drawers

GT-5K_G30026_ (Note 2)

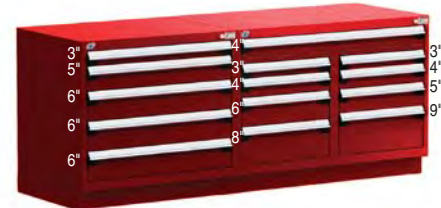

14 Drawers

GT-5KUG30004_

Width: 84"

TOOLBOXES

2 UNDER THE WORK SURFACE

38" H



5 Drawers

GT-5A_G34006



5 Drawers

GT-5A_G34008



3 Drawers

GT-5A_G34010



4 Drawers

GT-5A_G34012



10 Drawers

GT-5K_G34002 (Note 2)



8 Drawers

GT-5K_G34004 (Note 2)



8 Drawers

GT-5K_G34006 (Note 2)



9 Drawers

GT-5K_G34008 (Note 3)



Integrated Swing Doors - 2 Shelves

GT-5A_G34014 (Note 4)



Integrated Sliding Doors - 2 Shelves

GT-5A_G34018 (Note 1)



10 Drawers

GT-5K_G34010 (Note 3)



11 Drawers

GT-5K_G34012 (Note 3)



14 Drawers

GT-5KLG34002

Width: 72"



14 Drawers

GT-5KUG34002

Width: 84"



14 Drawers

GT-5KRG34002

Width: 96"

TOOLBOXES

5A SIDE



Toolboxes can be ordered on their own or as components of a workcenter as featured on [pages 18-31](#).

- Multi-drawer cabinets include stabilizing bars to provide extra rigidity to the housing
- An L3 standard lock is included on all preconfigured toolbox models. For an L50 electronic lock, contact Customer Service
- A range of optional accessories are also available



SOME OF OUR MOST POPULAR MODELS ARE SHOWN BELOW:

Widths: 1 bank of drawers: 24" (C); 30" (D); 36" (E); 42" (G); 48" (H); 54" (J); 60" (K);
 3 banks of drawers: 48" (H); 54" (J); 60" (K);
 4 banks of drawers: 96" (R);

Depth: 27"

Heights: 42", 48", 62" (including the 4"H base)

NOTE	WIDTH	
1	H (48"W)	1 bank 48"W, 2 banks 24"W
	J (54"W)	1 bank 54"W, 1 bank 18"W, 1 bank 36"W
	K (60"W)	1 bank 60"W, 2 banks 30"W

NOTE: The 18"W and 24"W banks of drawers are always installed on the left side of a 54"W or 60"W housing.

Widths: C, D, E, G, H, J, K
 Base: S = stainless steel; P = painted steel
 Fronts: blank = painted steel; S = stainless steel

GT-5A_G34002

42" H



12 Drawers

GT-5K_G38002_ (Note 1)

48" H



9 Drawers

GT-5A_G44010_

62" H



15 Drawers

GT-5K_G44010_ (Note 1)



17 Drawers

GT-5K_G44004_ (Note 1)

48" H



16 Drawers

GT-5K_G44008_ (Note 1)



8 Drawers

GT-5A_G44008_

62" H



15 Drawers

GT-5K_G58004_ (Note 1)



14 Drawers

GT-5K_G58006_ (Note 1)



Toolboxes can be ordered on their own or as components of a workcenter as featured on [pages 18-31](#).

- An L3 standard lock is included on all preconfigured toolbox models. For an L50 electronic lock, contact Customer Service
- Preconfigured models include 6" polyurethane casters (total height: 7 1/2"), including two rigid and two swivel casters with total-lock brakes. 4" polyurethane casters are also available
- A range of optional accessories are also available



SOME OF OUR MOST POPULAR MODELS ARE SHOWN BELOW:

Widths: 1 bank of drawers: 30" (D); 36" (E); 48" (H); 54" (J); 60" (K);
 3 banks of drawers: 48" (H); 54" (J); 60" (K);
 4 banks of drawers: 72" (L); 78" (V); 84" (U); 96" (R); 108" (S);

Depth: 27"

Heights: 37 1/2", 41 1/2", 45 1/2" (including casters)

NOTE	WIDTH	
1	H (48")	1 bank 48"W, 2 banks 24"W
	J (54")	1 bank 54"W, 1 bank 18"W, 1 bank 36"W
	K (60")	1 bank 60"W, 1 bank 24"W, 1 bank 36"W

NOTE: The 18"W and 24"W banks of drawers are always installed on the left side of a 54"W or 60"W housing.

GT-5B_30002P_

Widths: D, E, H, J, K
 Fronts: blank = painted steel; S = stainless steel

37 1/2"H



6 Drawers

GT-5B_G30002P_



5 Drawers

GT-5B_G30004P_



4 Drawers

GT-5B_G30008P_



10 Drawers

GT-5G_G30006P_ (Note 1)

41 1/2"H



7 Drawers

GT-5G_G34006P_ (Note 1)



10 Drawers

GT-5G_G34004P_ (Note 1)

45 1/2" H



12 Drawers

GT-5G_G38010P_ (Note 1)



16 Drawers

GT-5G_G38002P_ (Note 1)

TOOLBOXES

MOBILE

37 1/2" H



6 Drawers

GT-5G_G30010P_(Note 1)

41 1/2" H



9 Drawers

GT-5G_G34008P_(Note 1)

45 1/2" H



9 Drawers

GT-5G_G38012P_(Note 1)



11 Drawers

GT-5G_G38014P_(Note 1)

37 1/2" H



12 Drawers

GT-5GLG30002P_

Width: 72"



13 Drawers

GT-5GUG30002P_

Width: 84"



13 Drawers

GT-5GRG30002P_

Width: 96"

41 1/2" H



14 Drawers

GT-5VVG34002P_

Width: 78"



14 Drawers

GT-5GLG34002P_

Width: 72"



13 Drawers

GT-5GRG34002P_

Width: 96"

45 1/2" H



15 Drawers

GT-5VVG38002P_

Width: 78"



13 Drawers

GT-5GRG38002P_

Width: 96"



16 Drawers

GT-5GSG38002P_

Width: 108"

HANGING SIDE CABINET - SIDE ACCESS



- For additional storage space in your mobile toolbox, consider our hanging side cabinets.
- Adjustable shelves in 1" increments c/c
- Available with bottom and adjustable shelves
- Both shelf types are compatible with SH52 dividers
- For 27"D toolboxes
- Load capacity: 600lb. per cabinet
- Choice of door. Complete the product number as follows:
 - **01**: Solid door
 - **02**: Polycarbonate door

W x D x H		NO. OF ADJUSTABLE SHELVES (RD05)
27" x 14" x 24"	R5QPA-24__	-
27" x 14" x 28"	R5QPA-28__	1
27" x 14" x 30"	R5QPA-30__	1
27" x 14" x 34"	R5QPA-34__	1
27" x 14" x 38"	R5QPA-38__	2

POLYURETHANE CASTERS



4"



6"

- Polyurethane casters provide ultra-quiet and excellent maneuverability without marking floors
- 4" and 6" casters available in rigid, swivel and swivel with total-lock brake, with 440lb. and 1,100lb. load capacity per wheel respectively
- An optional directional locking pedal is available for swivel casters (4" and 6") for better control over long distances

PRODUCT NO.	CASTER TYPE	HEIGHT	ACTUAL HEIGHT
RB81-01	Rigid	4 "	5 1/8"
RB81-02	Swivel	4 "	5 1/8"
RB81-03	Swivel with total-lock brake	4 "	5 1/8"
RB84-01	Rigid	6 "	7 1/2"
RB84-02	Swivel	6 "	7 1/2"
RB84-03	Swivel with total-lock brake	6 "	7 1/2"
RB8E-02	Swivel caster directional locking kit		

NOTE: Directional locking pedals are sold in pairs.

SIDE HANDLE



- Wide-grip handle for easier toolbox handling

PRODUCT NO.	ACTUAL DEPTH OF HANDLE
RB90-27	24"



LOCK-IN MECHANISM



Activates when handle is lifted



Closes with a simple push

- Each drawer includes a lock-in mechanism that automatically activates when the drawer is opened
- Stops drawer from opening on its own

PRODUCT NO.
A

FOLDAWAY SHELF



- Provides an additional work surface
- Folds easily to the side when not in use
- Includes a protective neoprene surface

PRODUCT NO.	W x D
RC00-152701	15" x 27"

SIDE AND BACK STOP FOR FOLDAWAY SHELF



- Prevents parts and tools from falling
- Height: 1"

PRODUCT NO.	WIDTH
RC01-15	15"
RC01-27	27"



Troy High School (IL)

TOOLBOXES

TOOLBOX ACCESSORIES



STAINLESS STEEL TOP



- Acts as a work surface and protects the top of the cabinet from impacts
- Particle board top with stainless steel cover (#4 brushed finish)
- Excellent chemical resistance
- Excellent corrosion resistance
- Welded corners for an attractive appearance
- Available in 12ga or 16ga steel (12ga steel top provides better impact resistance)
- 12ga top thickness: 1³/₁₆"
- 16ga top thickness: 1³/₄"

PRODUCT NO.	W × D
RC35-2427-__	24" × 27"
RC35-3027-__	30" × 27"
RC35-3627-__	36" × 27"
RC35-4227-__	42" × 27"
RC35-4827-__	48" × 27"
RC35-5427-__	54" × 27"
RC35-6027-__	60" × 27"

NOTE: Complete number with 12 for a 12-gauge steel top.

MARINE EDGE STAINLESS STEEL TOP

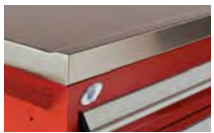

- The edge stops hardware and liquids from falling off
- Acts as a work surface and protects the top of the cabinet from impacts
- Particle board top with stainless steel cover (#4 brushed finish)
- Excellent chemical resistance
- Excellent corrosion resistance
- Welded corners for an attractive appearance
- Available in 12ga or 16ga steel (12ga steel top provides better impact resistance)
- 12ga top thickness: 1³/₁₆" and 2" edge
- 16ga top thickness: 1³/₄" and 1⁵/₁₆" edge

PRODUCT NO.	W × D
RC35-2427-__M	24" × 27"
RC35-3027-__M	30" × 27"
RC35-3627-__M	36" × 27"
RC35-4227-__M	42" × 27"
RC35-4827-__M	48" × 27"
RC35-5427-__M	54" × 27"
RC35-6027-__M	60" × 27"

NOTES: Add 12 to the product number for a 12ga steel top, or 16 for a 16ga steel top.
Not compatible with the nitrile or neoprene rubber mat.

We have a wide range of accessories so you can gain maximum benefit from your toolbox. Take a look at our selection of tops, doors, stacking cabinets, and other useful add-ons.

PAINTED STEEL TOP



- Acts as a work surface and protects the top of the cabinet from impacts
- Particle board top with painted steel cover
- Welded corners for an attractive appearance
- Thickness: 1³/₄"

PRODUCT NO.	W × D
RC37-2427	24" × 27"
RC37-3027	30" × 27"
RC37-3627	36" × 27"
RC37-4227	42" × 27"
RC37-4827	48" × 27"
RC37-5427	54" × 27"
RC37-6027	60" × 27"

PAINTED STEEL COVER



- Adds a protective work surface to the top of the toolbox
- Welded corners for an attractive appearance
- Compatible with the toolbox lock

PRODUCT NO.	W × D
RC38-2427L	24" × 27"
RC38-3027L	30" × 27"
RC38-3627L	36" × 27"
RC38-4227L	42" × 27"
RC38-4827L	48" × 27"
RC38-5427L	54" × 27"
RC38-6027L	60" × 27"

STAINLESS STEEL COVER



- Adds a protective work surface to the top of the toolbox
- Stainless steel adds stylish aesthetics
- Excellent chemical resistance
- Excellent corrosion resistance
- Welded corners for an attractive appearance
- Compatible with the toolbox lock

PRODUCT NO.	W × D
RC39-2427L	24" × 27"
RC39-3027L	30" × 27"
RC39-3627L	36" × 27"
RC39-4227L	42" × 27"
RC39-4827L	48" × 27"
RC39-5427L	54" × 27"
RC39-6027L	60" × 27"

NITRILE RUBBER MAT



- Nitrile mat with excellent hydrocarbon and shock resistance
- Thickness: 3/16"

PRODUCT NO.	W x D
RG48-2427	24" x 27"
RG48-3027	30" x 27"
RG48-3627	36" x 27"
RG48-4227	42" x 27"
RG48-4827	48" x 27"
RG48-5427	54" x 27"
RG48-6027	60" x 27"

NOTE: Not compatible with the marine edge stainless steel top.

NEOPRENE RUBBER MAT



- Neoprene mat for protecting the work surface
- Thickness: 1/8"

PRODUCT NO.	W x D
RG45-2427	24" x 27"
RG45-3027	30" x 27"
RG45-3627	36" x 27"
RG45-4227	42" x 27"
RG45-4827	48" x 27"
RG45-5427	54" x 27"
RG45-6027	60" x 27"

NOTE: Not compatible with marine edge stainless steel top.

ADJUSTABLE KICK PLATE FOR LEVELING GLIDES



- Provides an immaculate finish
- Prevents dust from entering
- Available in stainless steel only
- Please contact your customer service representative for more details

LEVELING GLIDES



- For easy height adjustment and leveling of toolbox without removing drawers (1 1/8" to 2" from the ground)
- Compatible with toolbox bases
- Sold in packs of 4

PRODUCT NO.
RA74-01

SIDE UTILITY PANEL



- Maximizes toolbox storage space
- Installs on the sides of toolboxes
- Compatible with all WM9_ hooks and holders

119

PRODUCT NO.	DEPTH
RC02-27_	27"

NOTES: Complete the product number with the housing height required:
28", 30", 34", 38", 44", 58".
Full height installation only.
Not compatible with RC00 foldaway shelves.

BUMPERS FOR TOOLBOXES



- Protects toolboxes from bumps and damage
- Protection kit for all four corners of toolboxes
- Vertical bumpers and endcaps made from resistant soft PVC
- Quick and easy installation with double-sided adhesive tape
- Tool-free installation

PRODUCT NO.	COMPATIBLE WITH
RB9J-_ 01	RA30/RA35 toolbox
RB9J-_ 02	RA30/RA35 toolbox and RD01 side cabinet
RB9J-_ 03	RA30/RA35 toolbox and 1 RC02/RC04 side panel
RB9J-_ 04	RA30/RA35 toolbox and 2 RC02/RC04 side panels

NOTES: Complete the product number with the housing height required:
28", 30", 34", 38", 44", 58".
Not compatible with RC00 foldaway shelves.

SIDE PLASTIC BIN PANEL



- Maximizes toolbox storage space
- Holds RG20 plastic bins
- Installs on the sides of toolboxes
- Compatible with all commercially available brands of plastic bins with a hanging lip

118

PRODUCT NO.	DEPTH
RC04-27_	27"

NOTES: Complete the product number with the housing height required:
28", 30", 34", 38", 44", 58".
Full height installation only.
Not compatible with RC00 foldaway shelves.



TOOLBOXES

TOOLBOX ACCESSORIES

STACKING CABINET



- For storage of large and bulky items, choose a stacking cabinet.
- Shelves are height adjustable in 1" increments c/c and include an edge that prevents items from falling
- Housing heights available: **24"** and **30"**
- Available with or without doors (solid steel or polycarbonate)
- A range of dimensions available

PRODUCT NO.	W x D
R5HDG-___	30" x 27"
R5HEG-___	36" x 27"
R5HHG-___	48" x 27"
R5HJG-___	54" x 27"
R5HKG-___	60" x 27"

NOTE: When ordering, specify the housing height and type of door required:
e.g., R5HEG-24 03 for a 36"W x 27"D x 24"H cabinet with double integrated doors.

DOOR TYPE	CABINET WIDTHS				
	30"	36"	48"	54"	60"
00 Without door	X	X	X	X	X
01 Single integrated door	X	X			
02 Single integrated polycarbonate door	X	X			
03 Double integrated doors	X	X	X	X	X
04 Double integrated polycarbonate doors	X	X	X	X	X
05 Double doors with frame	X	X	X	X	X
06 Double polycarbonate doors with frame	X	X	X	X	X
07 Integrated sliding doors			X	X	X
08 Integrated sliding polycarbonate doors			X	X	X
09 Sliding doors with frame			X		X
10 Sliding polycarbonate doors with frame			X		X

DOORS



- Doors are ideal for secure and discrete storage.
- Available in the following combinations: single or double (double door can be sliding), polycarbonate or solid steel
- All door models include an L3 standard lock
- L50 electronic locks can be fitted on swing doors. Contact Customer Service for more details

PRODUCT NO.	TYPE	SURFACE
RB62	Single integrated	Steel
RB67	Double integrated	Steel
RB75	Double with frame	Steel
RB50	Integrated sliding	Steel
RB55	Sliding with frame	Steel
RB61	Single integrated	Polycarbonate
RB66	Double integrated	Polycarbonate
RB76	Double with frame	Polycarbonate
RB51	Integrated sliding	Polycarbonate
RB56	Sliding with frame	Polycarbonate

SLOPED TOP



- Keeps the workspace clean and tidy while reducing clutter
- 16° slope angle
- Height: 8"

PRODUCT NO.	W x D
RC31-362708	36" x 27"
RC31-422708	42" x 27"
RC31-482708	48" x 27"
RC31-542708	54" x 27"
RC31-602708	60" x 27"

ELECTRONIC LOCK SYSTEM



- Simple, fast and easy to use
- No key required
- Up to 20 different users
- 4-to 8-digit access codes
- Retrofits on existing Rousseau R or L cabinets with drawers
- Simplifies access management to drawers
- Can be used in all configurations of cabinets with drawers
- Compatible with RC35 and RC37 tops

PRODUCT NO.	FOR
RB00-DDHHL50	RA30 (R Cabinet)
RB01-WWDDHHL50	RA35 (Multi-Drawer Cabinet)
LB00-DDHHL50	LA30 (L Cabinet)

NOTE: Not compatible with RC38 and RC39 tops.

DRAWER WITH STAINLESS STEEL FRONT



- Adds stylish aesthetics to workstations and toolboxes
- Excellent chemical and corrosion resistance
- #4 brushed finish

RF35-__27__	Drawer widths: 18", 24", 30", 36", 42", 48", 54", 60"
	Drawer heights: 03", 04", 05", 06", 07", 08", 09", 10", 12", 14"

NOTE: Order an RA30 or RA35 housing and RF35 drawers with stainless steel fronts.



The R2V Vertical Storage System is the only product of its type on the market. Stacked above an R cabinet (sold separately), it is ideal for storing more tools and equipment while keeping them within easy reach. By using all vertical space available, you can free up floor space and stay perfectly organized.

The drawers – which are fitted with a lock-in mechanism – open to full extension and boast a load capacity of 200lb. They provide high-density and tidy storage, which helps boost your productivity and efficiency.

- Widths: 24", 30", 36", 42", 48", 54" and 60"
- Depth: 27"
- Heights: 34" and 38"
- Drawer widths: 6", 7", 8", 9", 10", 11" and 12"

DISTINCTIVE FEATURES

DRAWER INTERIOR

Pale-gray interior for better visibility

ERGONOMIC HANDLE

Comfort-grip handle with integrated drawer lock-in mechanism



ORGANIZATION

Front and rear panels with perforations for hanging tools. Optional utility panels and 5S accessories also available



LOCKS

Standard lock included on all models. Optional electronic lock and two-user lock also available

100% EXTENSION

Quick and easy access and identification of tools

HEIGHT COMBINATIONS

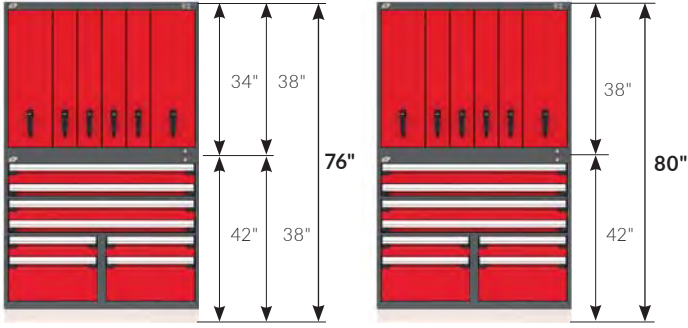

DRAWER SUBDIVISION

To subdivide your drawers, see the layouts and accessories on [pages 57 and 58](#).

OPTIONS UNDERNEATH

- TOOLBOX 43-46
- REEL CABINET 63
- CABINET WITH WASTE AND RECYCLING DRAWER 10

NOTES: The R2V Vertical Storage System must be installed on top of an R cabinet of the same width. It cannot be installed directly on the ground.

For stability reasons, the stacked cabinet must be anchored to the R cabinet underneath.

For compatibility with RD86/87 storage unit, contact Customer Service.

There is no mobile version of this product available.

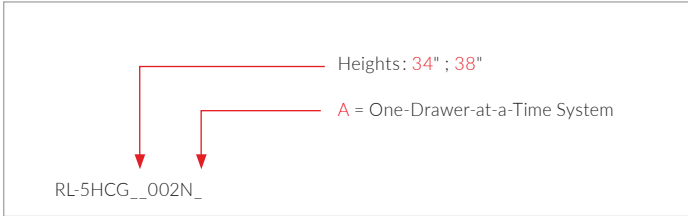

24" W



3 drawers

RL-5HCG__002N_



3 drawers

RL-5HCG__004N_



2 drawers

RL-5HCG__006N_

30" W



3 drawers

RL-5HDG__002N_



4 drawers

RL-5HDG__004N_



3 drawers

RL-5HDG__006N_

36" W



4 drawers

RL-5HEG_002N_



4 drawers

RL-5HEG_004N_



3 drawers

RL-5HEG_006N_

42" W



4 drawers

RL-5HGG_002N_



5 drawers

RL-5HGG_004N_



4 drawers

RL-5HGG_006N_

48" W



6 drawers

RL-5HHG_002N_



6 drawers

RL-5HHG_004N_



4 drawers

RL-5HHG_006N_

54" W



5 drawers
RL-5HJG_002N



6 drawers
RL-5HJG_004N



5 drawers
RL-5HJG_006N



5 drawers
RL-5HJG_008N

60" W



8 drawers
RL-5HKG_002N



6 drawers
RL-5HKG_004N



5 drawers
RL-5HKG_006N



6 drawers
RL-5HKG_008N



You have a project? Our specialists will help you find a customized solution. Contact us.

Choose the interior layout of each drawer using the preconfigured suggestions on this page. Complete your layouts with the accessories on [page 58](#) or [118-119](#) in the 5S section as needed.

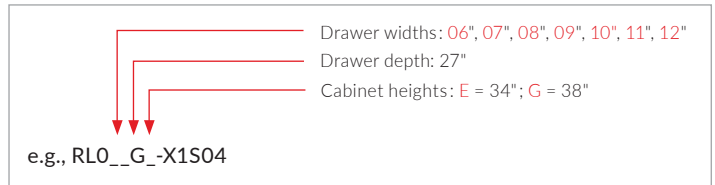

NOTES: 1: Hook perforations on both sides of the panel. Panel position is adjustable across the shelf width.
 2: Not available for 7"W drawers.
 3: Available for 10"W drawers and over.
 4: Panel position is adjustable across the shelf width.



Tray, 8 magnetic dividers

RLO__G_-T1001



Adjustable utility panel¹, 20 hooks

RLO__G_-U0C02



Side utility panel, 20 hooks, plastic bins²

RLO__G_-U0S03



2 trays, 12 magnetic dividers

RLO__G_-T2001



Adjustable utility panel¹, 2 trays, 16 magnetic dividers³

RLO__G_-X2C01



Side utility panel, 1 tray, 4 magnetic dividers, plastic bins²

RLO__G_-X1S04



SIDE UTILITY PANEL



- For locating tools quickly and easily
- Full-height and full-depth panel
- Installs on the far right of the drawer but can be easily repositioned on the left
- Color: Light Gray 071

PRODUCT NO.	CABINET HEIGHT
RL40-2734	34"
RL40-2738	38"

ADJUSTABLE UTILITY PANEL



- For locating tools quickly and easily
- Full-height and full-depth panel
- Tools can be hung on each side of the panel without obstructing the drawer
- Width adjustable in ½" increments c/c
- Color: Light Gray 071

PRODUCT NO.	CABINET HEIGHT
RL43-2734	34"
RL43-2738	38"

ADJUSTABLE TRAY



- Ideal for storing assorted products and tools (cans, bottles, etc.)
- Tool-free installation and adjustment
- Includes edges to prevent objects from falling to the bottom of the drawer
- Height adjustable in 1" increments (c/c)
- Compatible with side utility panels. For compatibility with adjustable utility panels, refer to technical guide R68
- Color: Light Gray 071

PRODUCT NO.
RL21-__27

NOTE: Complete the product number with the drawer width:
06", 07", 08", 09", 10", 11" and 12".

MAGNETIC DIVIDER

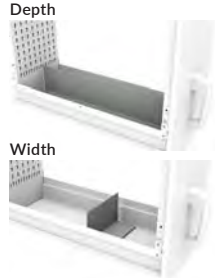

- Installs on drawer bottoms and adjustable trays
- Includes a magnetic strip for easy repositioning
- Divider height: 4"
- Color: Light Gray 071

PRODUCT NO.	DIVIDER
RL60-2704	Depth
RL61-__04	Width

NOTES: Complete the RL61 number with the drawer width:
06", 07", 08", 09", 10", 11" and 12".
Not compatible with non-slip drawer/tray liners.

NON-SLIP DRAWER/TRAY LINER



- Protects tools stored in the drawer or on a tray
- Thick 3/32"

PRODUCT NO.	DEPTH
RL49-__24	24"
RL49-__27	27"

NOTES: Complete the product number with the drawer width:
06", 07", 08", 09", 10", 11" and 12".
Not compatible with magnetic dividers.

ONE-DRAWER-AT-A-TIME SYSTEM **PATENTED**

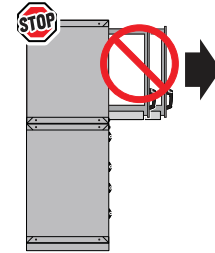

- Prevents more than one drawer from opening at the same time for greater stability
- To order: Add "A" to the model numbers on [pages 54-56](#)

L50 ELECTRONIC LOCK



- Simple, fast and easy to use
- No key required
- Up to 20 different users
- 4- to 8-digit access codes
- Can be used in all configurations of cabinets with drawers

PRODUCT NO.
RL00-__27L50

NOTE: Complete the product number with the cabinet width:
24", 30", 36", 42", 48", 54" and 60".

LABEL HOLDER



- For 7/8"H paper labels
- Label holder height: 1 5/16"
- Widths available: 6" and 9"

PRODUCT NO.	
RL81-__	Self-adhesive
RL82-__	Magnetic

NOTE: Complete the product number with the desired width: 06", 09".

Important: Refer to technical guide R68 for details on accessories compatibility.



CABINET FOR TWO USERS



Sharing toolboxes between two users is now easy with two-user access. Available for multi-drawer toolboxes and the R2V Vertical Storage System, two-user access allows each technician to lock their own bank of drawers individually. This solution is ideal when two employees share the same workstation and floor space is a challenge. Furthermore, by stacking R2V storage over an R toolbox, you can increase the number of tools stored without using any extra floor space.

- Widths available: 48" and 60"
- Two locks and two distinct locking mechanisms for each housing
- L3 standard lock or L50 electronic lock available
- Drawer banks split in two equal parts, from left to right

SAME WORK SHIFT

Each user has their own workstation while sharing the toolbox (R + R2V)

TOTAL WIDTH BEFORE: 18' *
TOTAL WIDTH AFTER: 14' **

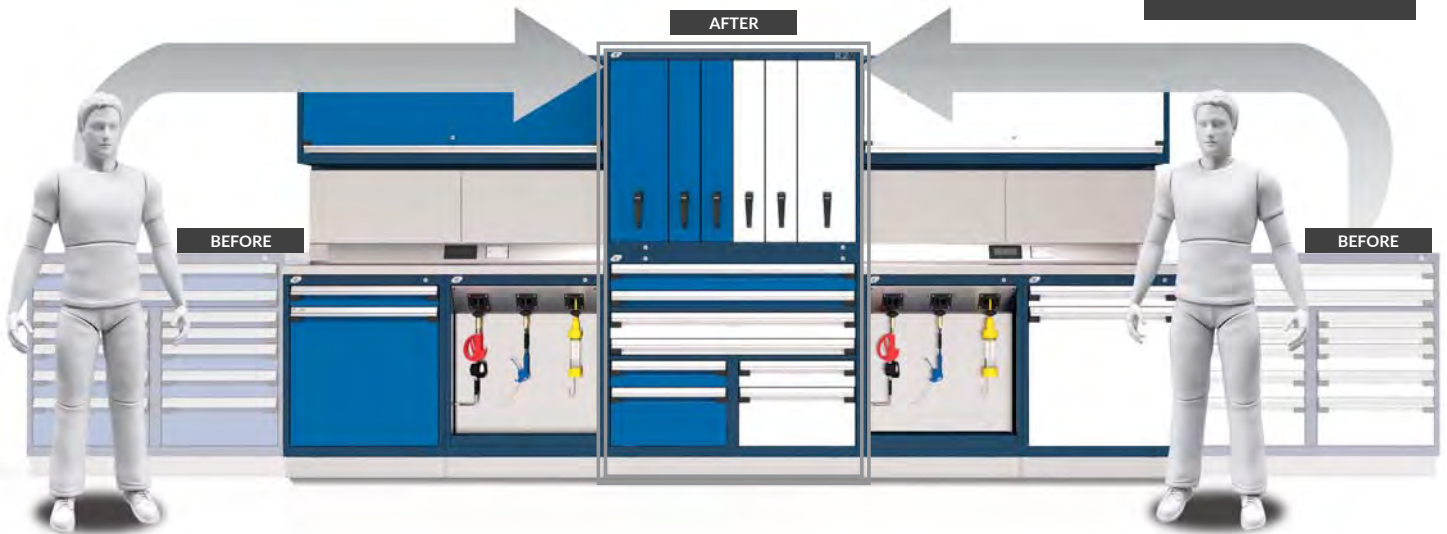

DIFFERENT WORK SHIFT

Users share the workstation space and the toolbox (R + R2V).

TOTAL WIDTH BEFORE: 13' *
TOTAL WIDTH AFTER: 9' **



* WITHOUT two-user access ** WITH two-user access
Different colors are only shown to help visualize the access and shared space for two different users.

CABINET FOR TWO USERS NEW

INDIVIDUAL LOCK FOR USER 1 AND 2



L3 LOCK

L50 LOCK

ONE-DRAWER-AT-A-TIME SYSTEM (OPTIONAL)

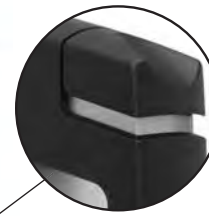
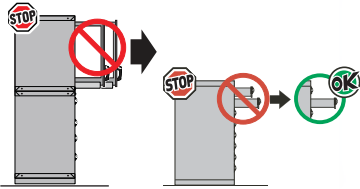

LOCK-IN MECHANISM

Each vertical drawer includes a mechanism to stop the drawer from opening on its own

SECURITY PANELS

Blocks access between two banks of drawers



RL91



RF92

RF91

HERE ARE SOME PRECONFIGURED MODELS



W x D x H

48" x 27" x 42"

R6KHG-3802S



W x D x H

48" x 27" x 76"

RL-XHG76D002NS



W x D x H

48" x 27" x 76"

RL-XHG76D004NS

FOR CUSTOMIZED MODELS:



R2V VERTICAL HOUSING

- An RL91 security panel must be ordered to separate the drawers

PRODUCT NO.	W x D
RL29-4827__-L3_	48" x 27"
RL29-6027__-L3_	60" x 27"

NOTES: Complete the product number with the cabinet height: **34"** or **38"**.

For an electronic lock, replace L3 with **L50**.

For a One-Drawer-at-a-Time mechanism, add **A** to the end of product number.



MULTI-DRAWER HOUSING

- RF91 and RF92 security panels must be ordered to separate full-width drawers and banks of drawers

PRODUCT NO.	W x D
RA34-4827__-L3_	48" x 27"
RA34-6027__-L3_	60" x 27"

NOTES: Complete the product number with the cabinet height: **28"**, **30"**, **34"**, **38"**, **44"** or **58"**. The height excludes the 4"H base.

An RA45 partition and RA46 cross tie must be ordered.

For an electronic lock, replace L3 with **L50**.

For a One-Drawer-at-a-Time mechanism, add **A** to the end of product number.

NOTES: Only the housing needs to be ordered for two users; the drawers and other accessories are the same as single-user access.

Two-user access cannot be added to an RA30, RA35 or RL30 cabinet.

For the ideal height combination to reach 76" or 80" high, [see page 54](#).



Ferrari Maserati Québec (QC)

We know every dealership is unique, which is why we offer a range of reel cabinets that vary according to the number of reels required and where they are placed.

- All our cabinets include a door and/or front panel for easy access and maintenance (optional lock available)
- Removable drip tray included
- Widths: 24", 30", 36" and 48"
- Heights: 30", 38" and 72" (without base)
- 4"H base and quick access panel: painted or stainless steel



CONSIDERATIONS

Placement of service reels is a very important consideration to achieve the optimal configuration for a technician's workcenter. When reels are to be integrated into the workcenter, we help you determine the best place to store them.

After analyzing technicians' movements between the workcenter and vehicle, we have the following recommendations:

- Place toolboxes near to the technician, under the work surface
- Place reel cabinets in direct line with the automobile, beside the work surface. The reels will therefore not block access to the work surface
- If many different tools are used, we recommend storing the most frequently used tools below the work surface and others in toolboxes at the sides of the work surface

The technician's overall efficiency is increased when there is fast and easy access to tools, and direct and safe access to service reels.

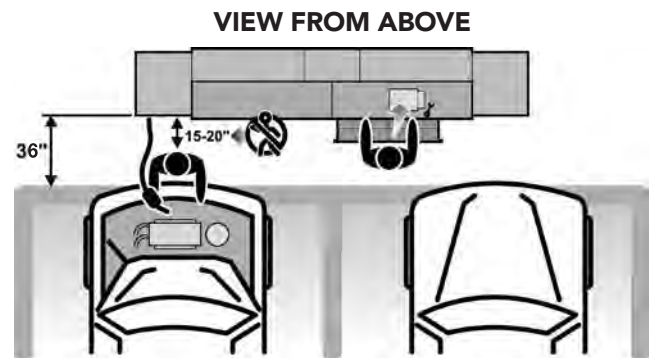

NOTES: It is your responsibility to check if there are any regulations regarding reel locations in your region. Reels are not available from Rousseau.

5C REEL CABINETS



GT-REG720601S

Widths available: 24", 30" and 36". The cabinet can store up to six reels.

- Includes a 6"H drawer for meters or other storage and a removable drip tray above the drawer
- Height: 76" (including the 4"H base)
- Can be used in a workcenter or as a standalone unit

4" base and quick access panel: S = stainless steel; P = painted steel
 GT-RCG720401 _

NOTE: For a workcenter with a 40"H work surface that includes storage cabinets and finishing panels, we recommend combining the 42"H (including base) reel cabinet with a 38"H toolbox to obtain the same height as the workcenter (80"H).

76"H CABINET

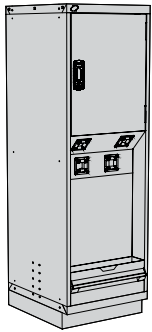

24"W - 4 openings

GT-RCG720401

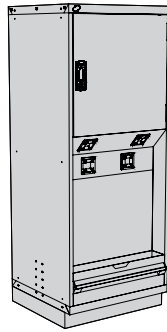

30"W - 4 openings

GT-RDG720401

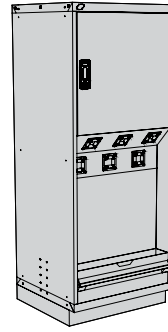

30"W - 6 openings

GT-RDG720601

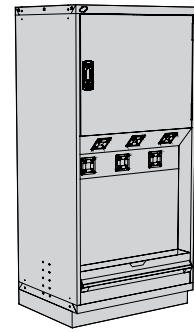

36"W - 6 openings

GT-REG720601



GT-C1105P



Easy access
(for installation
and maintenance)

Drip trays

6"H drawer



GT-5XEG1001P

Widths available: 24", 30" and 48". The cabinet can store up to six reels.

- The reel cabinet can be stacked on a toolbox (ordered separately). It can also be used in a workcenter or as a standalone unit
- Heights: 38" (without base) and 42" (with base)
- Includes a removable drip tray

GT-RCG380201

Quick access panel: S = stainless steel; P = painted steel
 Base: blank = without base; S = stainless steel; P = painted steel

NOTE: For a workcenter with a 40"H work surface that includes storage cabinets and finishing panels, we recommend combining the 42"H (including base) reel cabinet with a 38"H toolbox to obtain the same height as the workcenter (80"H).

38"H AND 42"H CABINETS

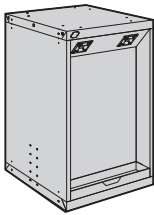

24"W - 2 openings

GT-RCG380201

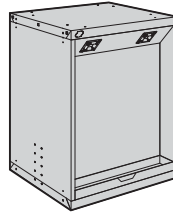

30"W - 2 openings

GT-RDG380201

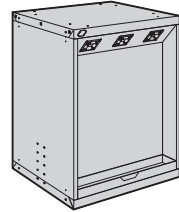

30"W - 3 openings

GT-RDG380301

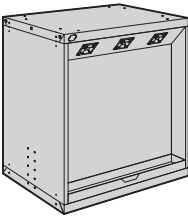

36"W - 3 openings

GT-REG380301

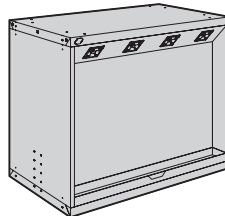

48"W - 4 openings

GT-RHG380401

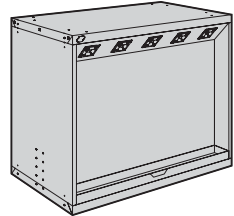

48"W - 5 openings

GT-RHG380501



GT-C1020P



Easy access
(for installation
and maintenance)

Drip tray

5C REEL CABINETS



GT-RHG300401P

Widths available: 24", 30" and 48". The cabinet can store up to five reels.

- Installs under the work surface
- Height: 34" (including the 4"H base)
- Includes a removable drip tray

GT-RCG300201  4"H base and quick access panel: S = stainless steel; P = painted steel

34"H CABINET

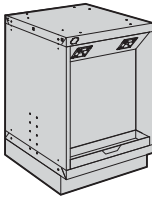

24"W - 2 openings

GT-RCG300201

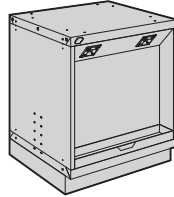

30"W - 2 openings

GT-RDG300201

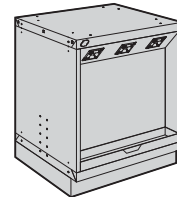

30"W - 3 openings

GT-RDG300301

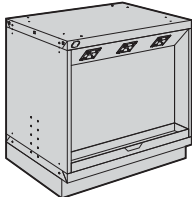

36"W - 3 openings

GT-REG300301

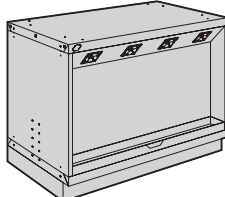

48"W - 4 openings

GT-RHG300401

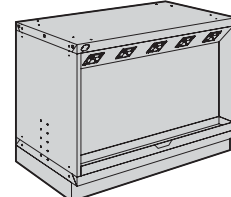

48"W - 5 openings

GT-RHG300501



GT-C1130S



Easy access
(for installation
and maintenance)

Drip tray

TRUE VERSATILITY AND FUNCTIONALITY



Ferrari Lake Forest (IL)

This is a great solution for your technicians: a unit that can safely store personal belongings as well as an oil barrel, a MultiTek Cart or an L Compact Mobile Cabinet.

- Heights available: 48", 76" and 80".
Can be used in a workcenter or as a standalone unit
- Two widths available for storage of different items. The 24"W unit can be combined with a MultiTek Cart or L Compact Mobile Cabinet. The 30"W unit can be combined with a MultiTek Cart, oil barrel or L Compact Mobile Cabinet
- Depth: 27"
- An L3 standard lock is included with storage units and lockers. For an L50 electronic door lock, contact Customer Service

SOME OF OUR MOST POPULAR MODELS ARE SHOWN BELOW:

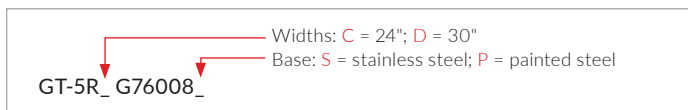

48"H



Door
GT-5R_G48002_ (Note 1)



Roll-Out Shelf, Door
GT-5R_G48004_ (Note 1)



Door
GT-5R_G48002_ (Note 2)



Clothes Hanging Rail, Door
GT-5R_G48001_ (Note 3)

NOTES: Heavy-duty drawers and roll-out shelves are not compatible with these storage units.
To ensure unit stability, the unit must be anchored to a workstation, toolbox, storage cabinet or the wall.



SLOPED TOP



- Keeps the workspace clean and tidy while reducing clutter
- Fits perfectly into the 5S storage method
- 16° slope angle
- Height: 8"

PRODUCT NO.	W × D
RC31-242708	24" × 27"
RC31-302708	30" × 27"

DOOR EXTENSION



- Compatible with RD86/RD87 storage cabinet doors
- Provides an immaculate finish
- Available in painted or stainless steel

PRODUCT NO.	W × H
RD__-2404	24" × 4"
RD__-3004	30" × 4"

NOTE: Add **81** to the product number for a painted steel extension, or **82** for a stainless steel extension.

NOTES:

1. MultiTek Carts and L Compact Mobile Cabinets must be ordered separately. The photos on [pages 65-68](#) feature the 37"H MultiTek Cart.
2. Oil barrels are not available from Rousseau. They are only compatible with 30"W cabinets.
3. For storage cabinets with clothes hanging rails, the height of the MultiTek Cart is 33". The MultiTek Cart must be ordered separately.

5D STORAGE UNITS

76"H



2 Shelves, Clothes Hanging Rail, Door

GT-5R_G76004_



2 Shelves, 2 Doors

GT-5R_G76006_(Note1)



2 Shelves, Door

GT-5R_G76007_(Note 1)



5 Shelves, Door

GT-5R_G76003_



Shelf, 2 Doors

GT-5R_G76002_(Note 2)



2 Shelves, Clothes Hanging Rail, 2 Doors

GT-5R_G76008_(Note 3)



Ferrari Maserati Québec (QC)



Valley Lexus (CA)

76"H



Shelf, 2 Half-Shelves, Half Clothes Hanging Rail, 2 Doors
GT-5R_G76014_ (Note 1)



2 Shelves, 3 Half-Shelves, Half Clothes Hanging Rail, Door
GT-5R_G76009_



Shelf, 2 Half-Shelves, 2 Half Clothes Hanging Rails, Door
GT-5R_G76011_



2 Shelves, 6 Half-Shelves, Door
GT-5R_G76010_



2 Roll-Out Shelves, Door
GT-5R_G76019_ (Note 1)



Shelf, 3 Half-Shelves (2 x 12"W, 1 x 18"W), 2 Doors
GT-5R_G76013_ (Note 1)



Roll-Out Shelf, Door
GT-5R_G76020_ (Note 2)



5 Roll-Out Shelves, Door
GT-5R_G76021_



2 Shelves, Clothes Hanging Rail, Door
GT-5R_G76022_ (Note 3)

5D STORAGE UNITS

80"H



Shelf, 3 Half-Shelves, 2 Doors

GT-5X_G80002_(Note 1)



3 Shelves, Clothes Hanging Rail, 2 Doors

GT-5X_G80004_



Shelf, 4 Half-Shelves, 2 Doors

GT-5X_G80006_



2 Shelves, 2 Doors

GT-5X_G80008_(Note 2)



Shelf, 2 Half-Shelves, Clothes Hanging Rail, Roll-Out Shelf, 2 Doors

GT-5X_G80010_



Shelf, 2 Half-Shelves, 2 Doors

GT-5X_G80012_(Note 2)

NOTES:

1. MultiTek Carts and L Compact Mobile Cabinets must be ordered separately. The photos on pages 65-68 feature the 37"H MultiTek Cart.
2. Oil barrels are not available from Rousseau. They are only compatible with 30"W storage cabinets.
3. For storage cabinets with clothes hanging rails, the height of the MultiTek Cart is 33". The MultiTek Cart must be ordered separately.



Prémont Harley-Davidson (QC)



Complexe Volkswagen 440 (QC)

Storage units and lockers are an ideal solution for secure storage of technicians' personal belongings or to provide additional storage space for a neat and organized workspace. They also integrate seamlessly with your workstations.

A wide selection of dimensions and options are available to meet your needs:

- Standard widths: 12", 15" and 18" (15"W and 18"W models will store a motorcycle helmet)
- Depth: 27"
- Heights: 48", 76" and 80" (including the 4"H base)
- Includes hanging zones for installing hooks inside the door
- An L3 standard lock is included with storage units and lockers. For an L50 electronic door lock, contact Customer Service
- Optional accessories include: leveling glides, shelf dividers, hooks and sloped tops

SOME OF OUR MOST POPULAR MODELS ARE SHOWN BELOW:

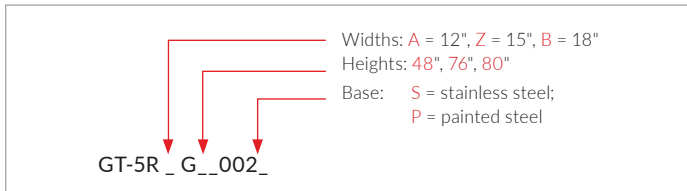

STORAGE CABINETS

DISTINCTIVE FEATURES



48"H Storage Cabinet,
2 Adjustable Shelves,
Solid Door

GT-5R _ G48001_

76"H or 80"H Storage Cabinet, 4 Adjustable Shelves,
Solid Door

GT-5R _ G __ 002 _

Heavy-duty and ergonomic handle



Vented door for lockers



Compatible with light-duty hooks



Pale-gray interior for better visibility



NOTES: Storage cabinets and lockers are sold unassembled.

To ensure unit stability, the unit must be anchored to a workstation, toolbox, storage cabinet or the wall.



5E STORAGE UNITS AND LOCKERS

LOCKERS



48"H Locker, 2 Hooks, Clothes Hanging Rail, Vented Door
GT-5R_G48003_



76"H or 80"H Locker, Adjustable Shelf, 2 Hooks, Clothes Hanging Rail, Vented Door
GT-5R_G_004_



76"H or 80"H Locker, 4 Hooks, 2 Clothes Hanging Rails, Middle Shelf, 2 Vented Doors
GT-5R_G_005_

ACCESSORIES

SLOPED TOP



- Keeps the workspace clean and safe while reducing clutter
- 16° slope angle
- Height: 8"

PRODUCT NO.	W × D
RK90-122708	12" × 27"
RK90-152708	15" × 27"
RK90-182708	18" × 27"

ADJUSTABLE SHELF



- For storage of equipment
- Height can be adjusted in 1" increments c/c
- Load capacity: up to 100lb.

PRODUCT NO.	W × D
RK93-1227	12" × 27"
RK93-1527	15" × 27"
RK93-1827	18" × 27"

HOOK



- Attaches under the shelf or top
- Load capacity: 10lb. per hook
- Sold individually

PRODUCT NO.	
RK94-01	1 Hook

PARTIAL DIVIDER



- Unique concept facilitates position changes
- Height: 5 1/2"
- Easy tool-free installation

PRODUCT NO.
SH52-2406

LEVELING GLIDES



- Adjusts your storage unit or locker to make it level

PRODUCT NO.	
RA75-01	Pack of 4

ADJUSTABLE KICK PLATE FOR LEVELING GLIDES



- Provides an immaculate finish
- Prevents dust from entering
- Only available in stainless steel
- Please contact your customer service representative for more details

MULTITEK CART

A COMPLETE AND INTEGRATED SOLUTION



Honda Queensway (ON)

To perform vehicle repairs and maintenance, technicians need a variety of tools and replacement parts near the vehicle and within easy reach. Every technician has their own way of working, and the requirements of each task can vary considerably between vehicles and between dealerships. The MultiTek Cart's design allows for a high level of personalization based on different work habits and requirements.

- Minimizes trips back and forth
- Transports tools, original parts and spare parts
- Ensures important tools are within easy reach
- Ergonomic working height
- 36"W x 24"D and 48"W x 24"D models are available on [page 114](#) in the Parts Department section

DISTINCTIVE FEATURES



LOCKABLE SECURITY COVER

Opens 90° for unrestricted access to the work surface. The cover features strategically placed gas springs to allow access to the top shelf when open. It is also equipped with a lock to secure the contents when closed.



COMFORTABLE AND ERGONOMIC HANDLES

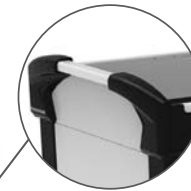

ROLL-OUT SHELF

Expand your work surface area with a roll-out shelf.

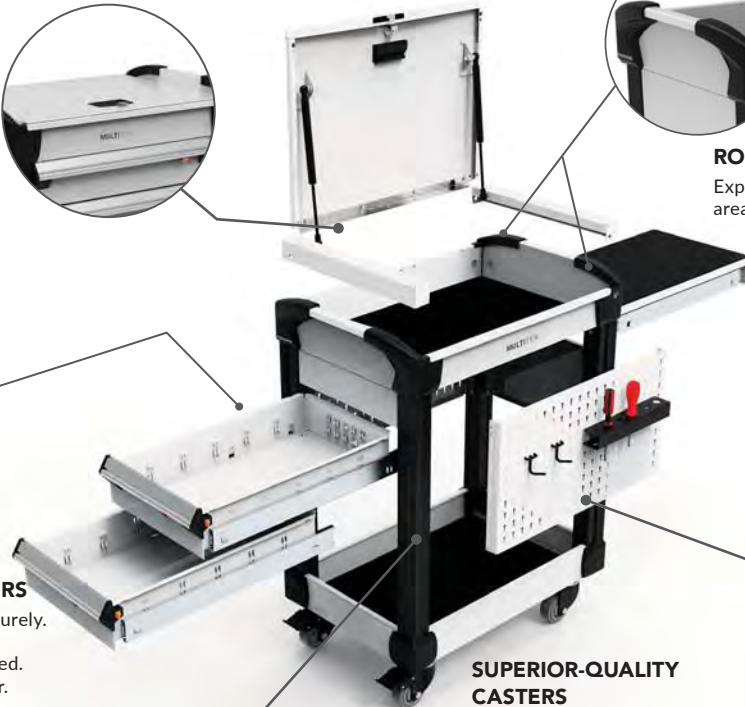

FRONT OR SIDE DRAWERS

Transport tools safely and securely. 4"H drawers feature a lock-in mechanism to keep them closed. 50lb. load capacity per drawer.

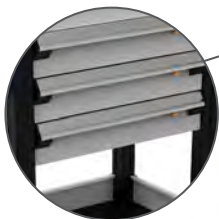

SUPERIOR-QUALITY CASTERS

UPRIGHT BUMPERS

Protect vehicles from accidental bumps.

FINISHING PANELS, UTILITY PANELS OR PLASTIC BIN PANELS

Add accessories to ensure everything you need is always within reach.

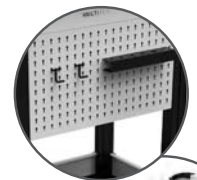

Whether you need just one unit or one hundred, our specialists will help you build your ideal configuration.

MULTITEK CART

FITS IN STORAGE UNITS AND UNDER WORK SURFACES



RV-_B__00N_01

The 16"D MultiTek Cart is designed to fit underneath the work surface, behind a hideaway door or inside a side storage unit.

- The 33"H MultiTek Cart is compatible with a 36"H workstation; the 37"H cart is compatible with a 40"H workstation and a 24"W or 30"W storage unit
- For a storage cabinet with clothes hanging rail, the 33"H MultiTek Cart must be used
- Only the 23"W version is compatible with RB59/60 and RD81/82 door extensions
- Each shelf can be lined with a rubber mat and has a 150lb. load capacity
- The side roll-out shelf is lined with a rubber mat, has a 15lb. load capacity and provides an extra work surface

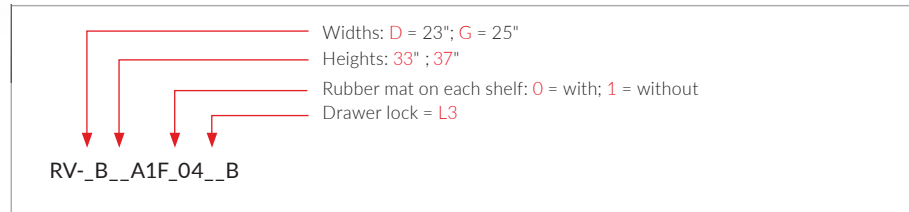

NOTES: 1: For this model without a rubber mat, replace the letter C with L.
2: See [page 119](#) for compatible hooks.



Front drawer

RV-_B__A1F_04__B



2 front drawers

RV-_B__A2F_04__B



Front drawer, side roll-out shelf



RV-_B__A1F_02__B



2 front drawers, side roll-out shelf

RV-_B__A2F_02__B



Front drawer, cover, utility panel

RV-_B__A1UC10__B (note 1 and 2)



2 front drawers, cover, utility panel, upright bumpers

RV-_B__A2UC12__B (note 1 and 2)





Side drawer

RV- B_ S1F_04_ B



2 side drawers

RV- B_ S2F_04_ B



2 side drawers, side roll-out shelf

RV- B_ S2F_06_ B



2 side drawers, side roll-out shelf, cover, utility panels, upright bumpers

RV- B_ S2X_02_ B (note 2)



Side drawer, side roll-out shelf

RV- B_ S1F_06_ B



Side roll-out shelf

RV- B_ 00F_01



Lévis Honda (QC)



Budds' Imported Cars (ON)

MULTITEK CART

INCREDIBLY PRACTICAL AND VERSATILE – NEXT TO THE WORK SURFACE

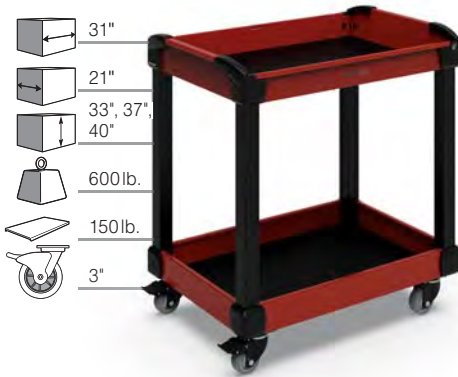

RV-NH__00K_01 (Note 3)

The 31"W x 21"D MultiTek cart is ideal as a freestanding unit. It offers plenty of storage space and multiple configurations. With this size, you can have roll-out half-shelves or half-drawers on both sides of the MultiTek Cart.

- Each shelf can be lined with a rubber mat and has a 150lb. load capacity
- The side roll-out shelf is lined with a rubber mat, has a 15lb. load capacity and provides an extra work surface

RV-NH__S1F_04__B

Heights: 33" ; 37" ; 40"
Rubber mat on each shelf: 0 = with; 1 = without
Drawer lock = L3

NOTES: 1: For this model without a rubber mat, replace the letter C with L.
2: See pages 119-120 for compatible hooks and plastic bins.
3: Sold unassembled.



Side drawer

RV-NH__S1F_04__B



2 side drawers



RV-NH__S2F_04__B



3 side drawers



RV-NH__S3F_04__B



3 front drawers, cover, plastic bins panels, upright bumpers

RV-NH__A3X_02__B (note 2)



3 front drawers, cover, utility panel, upright bumpers

RV-NH__A3UC16__B (note 1 and 2)



Side roll-out shelf



RV-NH__00F_01



Front drawer, 2 side roll-out half-shelves

RV-NH_A1F_06_B



2 front drawers, 2 side roll-out half-shelves

RV-NH_A2F_06_B



2 front drawers, 2 side roll-out half-shelves, cover, utility panels

RV-NH_A2UC06_B (note 1 and 2)



2 side half-drawers

RV-NH_B2F_02_B



Front drawer, 2 side half-drawers

RV-NH_M3F_02_B



2 side roll-out half-shelves

RV-NH_00F_02



3 shelves

RV-NH_00K_07 (Note 3)



3 shelves, utility panels

RV-NH_00U_07 (Note 2)



2 front drawers, cover, utility and plastic bin panels

RV-NH_A2X_08_B (Note 2)

MULTITEK CART

ACCESSORIES

NON-SLIP PVC LINER FOR SHELF



- Non-slip PVC protects items stored on shelves
- Thickness: 1/16"

PRODUCT NO.	W x D
RV__-2316-01	23" x 16"
RV__-2516-01	25" x 16"
RV__-3121-01	31" x 21"
RV__-3624-01	36" x 24"
RV__-4824-01	48" x 24"

NOTES: To order a PVC liner for a top or bottom shelf, add **44** to the product number.
To order a PVC liner for a middle shelf, add **74** to the product number.

NON-SLIP PVC LINER FOR DRAWER



- Non-slip PVC protects items stored in drawers
- Thickness: 1/16"

PRODUCT NO.	DRAWER	CART WIDTH
RV49-1623-01S	Side	23"
RV49-1623-01S	Side	25"
RV49-2131-01S	Side	31"
RV49-2131-01S2	Side half	31"
RV49-2316-01F	Front	23"
RV49-2516-01F	Front	25"
RV49-3121-01F	Front	31"

NOTE: Not compatible with partitions and dividers.

PROTECTIVE FOAM FOR SHELF



- Oil-resistant and non-absorbent foam protects items stored on shelves
- 1/4" blue foam

PRODUCT NO.	W x D
RV__-2316-01	23" x 16"
RV__-2516-01	25" x 16"
RV__-3121-01	31" x 21"
RV__-3624-01	36" x 24"
RV__-4824-01	48" x 24"

NOTES: To order protective foam for a top or bottom shelf, add **46** to the product number.
To order protective foam for a middle shelf, add **76** to the product number.

PROTECTIVE FOAM FOR DRAWER



- Oil-resistant and non-absorbent foam protects items stored in drawers
- 1/4" blue foam

PRODUCT NO.	DRAWER	CART WIDTH
RV41-1623-01S	Side	23"
RV41-1623-01S	Side	25"
RV41-2131-01S	Side	31"
RV41-2131-01S2	Side half	31"
RV41-2316-01F	Front	23"
RV41-2516-01F	Front	25"
RV41-3121-01F	Front	31"

TOOL FOAM FOR SHELF



- Missing tools can be spotted quickly with this oil-resistant and non-absorbent foam on shelves
- The blue foam is 1/4" thick and the black self-adhesive foam is 1/2" thick

PRODUCT NO.	W x D
RV__-2316-01	23" x 16"
RV__-2516-01	25" x 16"
RV__-3121-01	31" x 21"
RV__-3624-01	36" x 24"
RV__-4824-01	48" x 24"

NOTES: To order tool foam for a top or bottom shelf, add **47** to the product number.
To order tool foam for a middle shelf, add **77** to the product number.
Sold without cut-outs.

TOOL FOAM FOR DRAWER

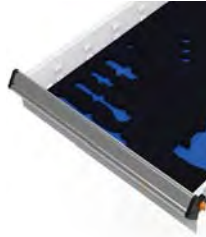

- Missing tools can be spotted quickly with this oil-resistant and non-absorbent foam in drawers
- The blue foam is 1/4" thick and the black self-adhesive foam is 1/2" thick

PRODUCT NO.	DRAWER	CART WIDTH
RV42-1623-01S	Side	23"
RV42-1623-01S	Side	25"
RV42-2131-01S	Side	31"
RV42-2131-01S2	Side half	31"
RV42-2316-01F	Front	23"
RV42-2516-01F	Front	25"
RV42-3121-01F	Front	31"

NOTE: Sold without cut-outs.

DRAWER LOCK



- Drawer can be locked with the same key used for other products (MultiTek Cart cover, toolboxes, storage cabinets, etc.)
- To order: Add **L3** to the product number

NOTE: 36"W x 24"D and 48"W x 24"D models are available in the parts department section on [page 114](#).

MIDDLE SHELF



- Load capacity: 150lb. per shelf, 600lb. max. per cart
- One or two shelves can be added to the cart
- Compatible with finishing panels, utility panels and plastic bin panels
- Thickness: 2"

PRODUCT NO.	W x D
RV25-2316	23" x 16"
RV25-2516	25" x 16"
RV25-3121	31" x 21"
RV25-3624	36" x 24"
RV25-4824	48" x 24"

LONG TOOL HOLDER



- For storing long tools, e.g., pry bars
- Easy to install
- Holds up to three long tools
- Space available for two smaller tools, e.g., screwdrivers

PRODUCT NO.	W x D x H
WM9Q-08	8" x 2" x 4"

STORAGE UNIT



- A storage unit is perfect for storing MultiTek Carts and L Compact Mobile Cabinets as well as providing enough storage space for personal belongings and other items.
- Available in different heights and configurations
- Optional door extension available
- Accessories available: fixed shelf, roll-out shelf, clothes hanging rail



PRODUCT NO.	TYPE OF BASE
RD86	Painted Steel Base
RD87	Stainless Steel Base

HIDEAWAY DOOR



- Integrates a MultiTek Cart into the workcenter
- Includes a handle to easily open the door
- Optional door extension available

PRODUCT NO.	W x H	MULTITEK HEIGHT
RB52-1834_ _ _	18" x 34"	33"
RB52-2134_ _ _	21" x 34"	33"
RB52-2434_ _ _	24" x 34"	33"
RB52-2734_ _ _	27" x 34"	33"
RB52-1838_ _ _	18" x 38"	37"
RB52-2138_ _ _	21" x 38"	37"
RB52-2438_ _ _	24" x 38"	37"
RB52-2738_ _ _	27" x 38"	37"

NOTES: Add **L3** to the end of the product number to order a hideaway door with lock.
Add **L** to the end of the product number to have the hinges on the left or **R** for the hinges on the right.

UPRIGHT BUMPERS



- Kit of four protective bumpers
- Protects vehicles, surrounding objects and the MultiTek Cart itself
- Made from soft PVC

PRODUCT #	MULTITEK CART (W x D)		
	23 x 16	31 x 21	36 x 24
RV63-29	33"H	33"H	35"H
RV63-33	37"H	37"H	39"H
RV63-36		40"H	42"H
RV63-42			48"H

CASTERS



- Available in two heights: 3" and 5"
- Sold in pairs
- Three types of casters available: fixed, swivel, swivel with brake
- Ultra-quiet casters
- Good chemical resistance to many products found in a vehicle garage (oils, hydrocarbons, water with de-icing salts, antifreeze, lubricants, etc.)

PRODUCT NO.	TYPE	HEIGHT	ACTUAL
RV82-01	Rigid	3"	4 1/4"
RV82-02	Swivel	3"	4 1/4"
RV82-03	Swivel with brake	3"	4 1/4"
RV83-01	Rigid	5"	6"
RV83-02	Swivel	5"	6"
RV83-03	Swivel with brake	5"	6"

NOTES: 23"W x 16"D, 25"W x 16"D and 31"W x 21"D MultiTek Carts include 3" casters by default.
36"W x 24"D and 48"W x 24"D MultiTek models include 5" wheels by default (see page 114)



Bays are often dedicated to specific functions, such as changing tires or express lube.

This means that different accessories may be required to create compact units that are tailored to the task being performed. This section features various suggestions for specialized workspaces.

To complete the product numbers, specify the type of finish for the base, top and power feed panel

e.g., GT-C1025_

Painted steel : P
Stainless steel : S

OIL CHANGE



MOBILE EXPRESS LUBE UNIT

- Keeps all the lube equipment you need within easy reach
- 8 sloped shelves with edge for damage-free transportation
- Includes containers for disposing of waste wherever you are

W × D × H
32" × 27" × 60"

PRODUCT NO.
WMA2072



BASIC OIL CHANGE STATION

- Organized and secure storage for oil change equipment (oil cans, towels, small tools, etc.)
- Power feed panel for constant access to power

W × D × H
48" × 30" × 36"
60" × 30" × 36"

PRODUCT NO.
GT-C1072_
GT-C1075_



QUICK OIL CHANGE STATION

- Multiple storage compartments for tools and equipment of assorted sizes
- Includes a waste & recycling door to keep the work surface clear and tidy
- Power feed panel for constant access to power

W × D × H
48" × 30" × 36"
60" × 30" × 36"

PRODUCT NO.
GT-C1073_
GT-C1076_



ILLUMINATED OIL CHANGE STATION

- Complete solution with drawer cabinet, waste & recycling door and top storage cabinet for even more storage
- LED light provides a well-lit work surface
- Power feed panel for constant access to power

W x D x H	PRODUCT NO.
48" x 30" x 76"	GT-C1074_
60" x 30" x 76"	GT-C1077_



COMPLETE OIL CHANGE STATION

- Reel cabinet with two openings and a removable drip tray for easy cleaning
- Top cabinet for taller items, such as bottles and cans
- Power feed panel for constant access to power
- Drawers of varying heights for flexible storage options

W x D x H	PRODUCT NO.
48" x 30" x 76"	GT-C1025_



OIL CHANGE STATION WITH COMPUTER CABINET

- Perform oil changes, book appointments and complete your invoicing all at the same workstation
- Reel cabinet with four openings and a removable drip tray for easy cleaning
- The hydraulic hoses are neatly hidden behind a door
- Drawers of varying heights for flexible storage options

W x D x H	PRODUCT NO.
48" x 30" x 76"	GT-C1019_

TIRE CHANGE



TIRE CHANGE STATION

- This compact workstation installs near tire changer machines to cut down on unnecessary trips back and forth
- Includes many plastic bins for well-organized storage of small parts
- Power feed panel for constant access to power
- Lots of storage for items of different sizes

W × D × H	PRODUCT NO.
36" × 30" × 76"	GT-C1071_

NOTE: The plastic bin panel is only available in painted steel.

VEHICLE PREPARATION



VEHICLE PREPARATION STATION

- Shelf for discreet storage of protective sheets for floor mats while keeping them within easy reach
- Includes a roll holder for car seat protective plastic wrap
- Waste & recycling doors for concealing the containers behind
- Top storage cabinet for keeping finishing equipment within easy reach

W × D × H	PRODUCT NO.
48" × 30" × 76"	GT-C1078_
60" × 30" × 76"	GT-C1079_

WHEEL ALIGNMENT



ALIGNMENT STATION

- Easily keep an eye on the screen while performing tire tests
- Install wheel alignment tools on the utility panel for quick access
- Power feed panel for constant access to power

W × D × H	PRODUCT NO.
96" × 30" × 76"	GT-C1170_

CAR DETAILING



WALL-MOUNTED CLEANING STATION

- Workspace designed to facilitate car detailing tasks
- Two storage cabinets for storing equipment after use
- Includes hooks and shelves to keep cleaning products within easy reach at all times

W × D × H	PRODUCT NO.
56" × 17" × 72"	WMC1000



WALL-MOUNTED DETAILING STATION

- Ideal for keeping the floor clear while cleaning or to prevent clutter accumulating under the work surface
- All detailing equipment can be stored in the wall-mounted cabinets

W × D	PAINTED STEEL	STAINLESS STEEL
60" × 30"	R5WH5-1010	R5WH5-6010



HAND WASHING



SINK STATION

- Provides a sink for technicians to wash their hands when needed
- Extra storage for towels and equipment
- Waste and recycling drawer for keeping the surface clean and tidy at all times

W × D × H	PRODUCT NO.
48" × 30" × 36"	GT-XHG0026S

NOTES : Work surface cutting is not provided by Rousseau.
Sink not included.



Can't find what you're looking for? Our specialists will help you find a customized solution. Contact us.

BASIC WORKBENCHES

A SOLUTION FOR EVERY NEED



Whether you need a basic workbench consisting of two legs and a top, or a more specialized table for mobile or stationary applications, we have a solution for every use case.

Our painted and stainless steel work surfaces are available in a wide range of dimensions, so you can have a single or double workbench tailored to your requirements.

Our solutions also provide unlimited layout possibilities, both above and below the work surface.



OPEN WORKBENCH – STATIONARY OR MOBILE

- With its sturdy construction and stylish aesthetics, this workbench fits in with almost any environment
- Height: stationary = 34"; mobile = 35"
- To order: Add **A** to the product number for the stationary version and **W** for the mobile version (includes a pair of 4" rigid casters and a pair of 4" swivel casters with total-lock brake system)
- Available with a painted steel or stainless steel top

W x D	PAINTED STEEL	STAINLESS STEEL
60" x 30"	WS_1031	WS_6031
72" x 30"	WS_1035	WS_6035
72" x 36"	WS_1039	WS_6039



MOBILE WORKBENCH WITH STORAGE UNIT

- The ideal combination of a work surface, storage unit and mobility
- Includes a back edge to prevent your tools and parts from falling
- Available with a painted steel or stainless steel top

W x D x H	PAINTED STEEL	STAINLESS STEEL
60" x 30" x 39"	LJ1013	LJ6013



CLOSED WORKBENCH WITH SLIDING DOORS AND CLOSED LEGS

- Provides secure and neat storage of various items with enclosed shelves underneath
- Includes two shelf levels (1 single and 1 double)
- Available with a painted steel or stainless steel top

W x D x H	PAINTED STEEL	STAINLESS STEEL
60" x 30" x 34"	WSA1170	WSA6170
72" x 30" x 34"	WSA1171	WSA6171
72" x 36" x 34"	WSA1172	WSA6172

BASIC WORKBENCHES



WORKBENCH WITH SLIDING DOOR - STATIONARY OR MOBILE

- Provides secure and neat storage of various items
- Height: stationary = 34"; mobile = 35"
- Includes two shelf levels (1 single and 1 double)
- To order: Add **A** to the product number for the stationary version and **W** for the mobile version (includes a pair of 4" rigid casters and a pair of 4" swivel casters with total-lock brake system)
- Available with a painted steel or stainless steel top

W x D	PAINTED STEEL	STAINLESS STEEL
60" x 30"	WS_1070	WS_6070
72" x 30"	WS_1071	WS_6071
72" x 36"	WS_1072	WS_6072



WALL-MOUNTED DETAILING UNIT

- Ideal for keeping floor space clear when cleaning or to avoid creating clutter under the work surface
- Includes two wall cabinets and a shelf under the work surface
- Leg height: 28"
- Available with a painted steel or stainless steel top

W x D	PAINTED STEEL	STAINLESS STEEL
60" x 30"	R5WH5-1010	R5WH5-6010



WALL-MOUNTED WORKBENCH ONLY

W x D	PAINTED STEEL	STAINLESS STEEL	
60" x 30"	WSK1001	WSK6001	Without shelf under work surface
60" x 30"	WSK1101	WSK6101	With shelf under work surface



TEARDOWN BENCH - STATIONARY OR MOBILE

- This workbench has been specially designed to allow liquids to drain cleanly and effectively when repairing transmissions
- The top includes a rim (back and sides) to prevent spills while oil is draining
- The steel surface includes a 2" dia. threaded drain for connecting a drainage pipe
- Stainless steel top

W x D	28"H LEG	32"H LEG	34"H LEG
48" x 30"	WS_7000	WS_7010	WS_7020
48" x 36"	WS_7001	WS_7011	WS_7021
60" x 30"	WS_7002	WS_7012	WS_7022
60" x 36"	WS_7003	WS_7013	WS_7023

WS_7000

- A: stationary
- W: with 4" casters: 2 rigid and 2 swivel with total-lock brake
- P: with 4" casters: 2 swivel and 2 swivel with total-lock brake



DRAWER UNIT WITH 6"H DRAWER

UNIT DEPTH	PRODUCT NO.
21"	LD75-3201__
27"	LD75-4201__



Order separately: Drip tray WSC01-01

NOTES: Add **L3** to the end of the product number to order a drawer lock.
Optional drip tray: WSC01-01.

BASIC WORKBENCHES



WORKBENCH WITH L COMPACT CABINET - STATIONARY OR MOBILE

- An L Compact Cabinet is ideal for storing small items and office supplies. With its painted or stainless steel top, this workbench is a great choice as part of a complete storage solution
- Add **G** to the product number for a 21"D cabinet, **H** for a 27"D cabinet and **J** for the mobile version (includes a pair of 4" rigid casters and a pair of 4" swivel casters with total-lock brake)
- Height: stationary = 34"; mobile = 35"
- A range of drawer accessories are also available

W x D	PAINTED STEEL	STAINLESS STEEL
60" x 30"	L_8131L3C	L_7131L3C
72" x 30"	L_8132L3C	L_7132L3C
72" x 36"	LH8133L3C	LH7133L3C



WORKBENCH WITH MULTI-DRAWER TOOLBOX

- The workbench with multi-drawer toolbox provides efficient storage for many different tools and also includes a power feed panel
- Available with a painted steel or stainless steel top and base

W x D x H	PAINTED STEEL	STAINLESS STEEL
48" x 27" x 34"	GT-XHG0018P	GT-XHG0018S
60" x 27" x 34"	GT-XKG0018P	GT-XKG0018S



WORKBENCH FOR SMALL AND MEDIUM-SIZED PARTS

- Ideal for storing tools of different sizes and dimensions in the same unit
- Two toolboxes: 1 x 36"W;
1 x 24"W with two roll-out shelves and integrated door
- Work surface width: 60"
- Available with a painted steel or stainless steel top and base

W x D x H	PAINTED STEEL	STAINLESS STEEL
60" x 30" x 34"	GT-XKG0004P	GT-XKG0004S



WORKBENCH WITH 12 DRAWERS

- Designed to store many different tools and items to maximize floor space
- Two toolboxes: 1 x 48"W
1 x 24"W
- Includes an oil-resistant rubber mat to protect the top of the workbench
- Available with a painted steel or stainless steel base

W x D x H	PAINTED STEEL	STAINLESS STEEL
72" x 27" x 34"	GT-XLG0010P	GT-XLG0010S

BASIC WORKBENCHES



MULTI-PURPOSE WORKSTATION

- A highly functional workstation that offers efficient storage and organization over and under the work surface
- Two toolboxes: 1 x 36"W
1 x 24"W with two roll-out shelves
- Includes two storage cabinets, an LED light and two privacy panels
- Available with a painted steel or stainless steel top and base

W x D x H	PAINTED STEEL	STAINLESS STEEL
60" x 30" x 80"	GT-XKG0006P	GT-XKG0006S



WORKBENCH WITH WASTE & RECYCLING DRAWER

- Designed to discreetly integrate waste and recycling bins under the work surface
- Two toolboxes: 1 x 48"W
1 x 24"W
- Available with a painted steel or stainless steel top and base

W x D x H	PAINTED STEEL	STAINLESS STEEL
72" x 30" x 34"	GT-XLG0012P	GT-XLG0012S



OPEN DOUBLE WORKBENCH

- With its sturdy construction and stylish aesthetics, this workbench fits in with almost any environment.
- It can be adapted to your requirements by simply adding accessories
- Includes one shelf level
- Available with a painted steel or stainless steel top

W x D x H	PAINTED STEEL	STAINLESS STEEL
96" x 30" x 34"	WSA1902	WSA6902
120" x 30" x 34"	WSA1904	WSA6904
144" x 30" x 34"	WSA1906	WSA6906



WORKBENCH WITH SLIDING DOORS

- Provides secure and neat storage of various items
- Two toolboxes: 2 x 60"W with two integrated sliding doors
- Includes two shelf levels
- Available with a painted steel or stainless steel top

W x D x H	PAINTED STEEL	STAINLESS STEEL
120" x 30" x 34"	R5XWG-3002	R5XWG-3004

BASIC WORKBENCHES

ACCESSORIES

WM BENCH FRAME



- Adds fast and efficient organization to your workstations
- The post has up to six installation zones for adding a wide range of accessories
- Can be retrofitted and is compatible with most workbenches on the market

PRODUCT NO.	W x H
WM11-5636	56" x 36"
WM11-5648	56" x 48"
WM11-6836	68" x 36"
WM11-6848	68" x 48"

OVERHEAD LED WORKSTATION LIGHT



- Provides optimized lighting for the work surface
- Installs on WM18 cantilever overhead supports (sold separately)
- Emits a brighter light than fluorescent tubes and is more energy efficient
- Installs on single or double WM frames
- Color temperature: 6000-7000K (cool)
- Includes a galvanized steel adapter
- Includes a 10' power cord
- The recommended operating temperature for our LED lights is between 5 and 40 °C (41 to 104 °F)
- An optional motion sensor can be added

PRODUCT NO.	SIZE	UPRIGHT WIDTH
WM43-3602_	36"W	28" and 34" c/c
WM43-4801_	48"W	28" and 56" c/c
WM43-4802_	48"W	34" c/c
WM43-6001_	60"W	34", 56" and 68" c/c
WM18-26	26"D	Cantilever Overhead Supports

NOTE: To order an LED light with motion sensor, add **MS** to the product number.

LCD MONITOR MOUNT AND KEYBOARD & MOUSE ARM



- Holds a computer monitor, keyboard and mouse
- Keyboard tray's usable area: 23½"W x 8½"D
- Includes an articulating arm with a single joint and an articulating arm with two joints
- The articulating arm with two joints provides extra adjustment options
- Compatible with most LCD monitors (max. 21") on the market
- Complies with VESA 75 and 100 monitor mounting standards
- Monitor and tray can be rotated and tilted

PRODUCT NO.	VERSION
WM05-22	For WM Bench Frame
WM06-22	Wall-mounted

TABLET ARM



- Compatible with most tablets on the market
- The clamps and mount have a non-slip surface to keep the tablet stable
- Includes an articulating arm with two joints
- The articulating arm with two joints provides extra adjustment options
- Tablet can be rotated and tilted
- Compatible tablet sizes:
 - Small: 7¾"W to 10"W (**01**)
 - Large: 9¾"W to 12¼"W (**02**)

PRODUCT NO.	VERSION
WM05-62_	For WM Bench Frame
WM06-62_	Wall-mounted

NOTE: Add **01** to the product number for the small version or **02** for the large version.

LCD MONITOR ARM



- Compatible with most LCD monitors (max. 21") on the market
- Complies with VESA 75 and 100 monitor mounting standards
- Includes an articulating arm with two joints
- The articulating arm with two joints provides extra adjustment options
- The monitor can also be tilted for better ergonomics

PRODUCT NO.	VERSION
WM05-03	For WM Bench Frame
WM06-03	Wall-mounted

LAPTOP ARM



- Holds a laptop, electronic device or any other object
- Tray's usable area: 14"W x 12"D
- Includes an articulating arm with two joints
- The articulating arm with two joints provides extra adjustment options
- Tray can be rotated and tilted

PRODUCT NO.	VERSION
WM05-42	For WM Bench Frame
WM06-42	Wall-mounted

SERVICE ADVISOR DESKS

WELCOMING - PROFESSIONAL - MODERN



Oxford Dodge Chrysler (ON)

Rousseau's service advisor desks create a dedicated space for greeting customers. As well as its welcoming and contemporary looks, it has been designed to facilitate all tasks performed by a service advisor. This includes initial greeting, delivery of keys, explanation of work to be performed, work order planning, car preparation and payment. For all this and more, the service advisor desk excels and impresses both visitors and advisors.

- Spacious work surface including a cable grommet to keep the surface clear
- Work surface and riser shelf have rounded fronts for a distinctive and welcoming look
- Choice of models with or without cabinet (18"W x 27"D x 38"H) to meet the advisor's needs
- Work surface and riser shelf options: stainless steel, gray laminate and wood
- No visible cables
- Sold assembled

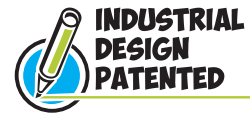

LAYOUT OPTIONS

Choose one or more stationary or mobile desks to meet the needs of your dealership. You can join stationary desks together in either a side-by-side or offset configuration. With a wide range of accessories available, you can build a truly personalized service advisor desk.

MOBILE



STATIONARY (SINGLE)



SIDE BY SIDE



OFFSET



SERVICE ADVISOR DESKS

METICULOUS DESIGNED TO PROVIDE AN ORGANIZED WORKSPACE

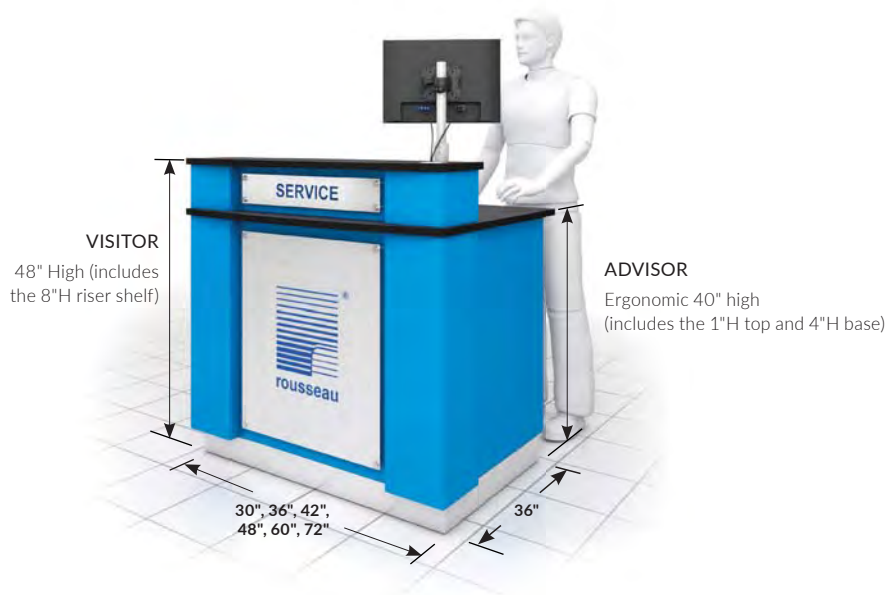

OPTIONS

Panel with or without personalization



Duotone



DESKTOP:

- LCD monitor mount
- Multiple top and riser shelf options

UNDER THE WORK SURFACE:

- Fixed shelf
- Waste and recycling containers
- Printer shelf
- Adjustable shelf
- Door with lock to secure personal belongings

UNDER THE RISER SHELF:

- Power outlets and USB ports
- LED light

WITH OR WITHOUT CABINET:

- Multiple drawer heights available
- 12"H drawer for file storage
- The drawer has a 100lb. load capacity and the total load capacity of the cabinet is 250lb.

STATIONARY AND MOBILE VERSIONS AVAILABLE

NOTE: To add accessories to preconfigured models, please contact Customer Service.

SERVICE ADVISOR DESKS

BUILD YOUR OWN

Follow the steps below to order your own customized service advisor desk. By choosing the various options available, you can build a desk that fulfills your requirements and matches your brand image. You can choose the top, finishing panels, and six different widths for both mobile and stationary desks.

1 Mobile = B; stationary = D
 2 Widths: D = 30"; E = 36"; G = 42"; H = 48"; K = 60"; L = 72"
 3 Top: 5 = laminate; 0 = stainless steel; 2 = wood
 4 Panel: P = painted steel; S = stainless steel

RP-__J38_0020S_

Complete the model number on [pages 90 and 91](#) with the options below.

1

MOBILE (B)



- Includes 2" casters for moving the desk easily when required
- Four casters are included for desks with two legs
- Six casters are included for models with one leg and a cabinet

NOTE: Side-by-side desks and offset desks cannot be mobile.

STATIONARY (D)



- The stainless steel bases include leveling glides for easy leveling
- Includes four leveling glides, except the 60"W and 72"W versions with cabinet, which include five
- Side-by-side and offset configurations are possible by adding desk joining kit RP-K001S

2

WIDTHS: 30" (D); 36" (E); 42" (G); 48" (H); 60" (K); 72" (L)

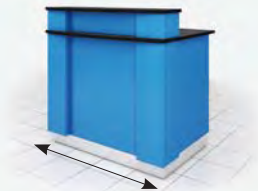

3

TOPS

Tops and riser shelves have rounded corners (visitor side).



STAINLESS STEEL (0)

Laminate and stainless steel versions have an aesthetic and durable black edging.



GRAY LAMINATE (5)



WOOD (2)

Wood adds a warm and distinctive look.

4

NO PANEL

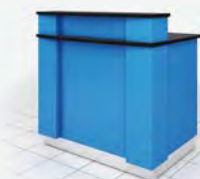

NOTE: No code to add.
Base models come without a panel.

WITH PAINTED (P) OR STAINLESS (S) STEEL PANEL



- With this option, you can personalize your desk by adding a logo or name.

94

NOTE: Not available for the 30"W version.

FOR DUOTONE



- Simply specify your chosen colors when ordering. There is no code to add.

5

ACCESSORIES

93

To join two or more service advisor desks together, side by side or offset, please order desk joining kit RP-K001S.

92

NOTE: Side-by-side desks and offset desks cannot be mobile.



SERVICE ADVISOR DESKS

FRONT VIEW FOR PRECONFIGURED MODELS

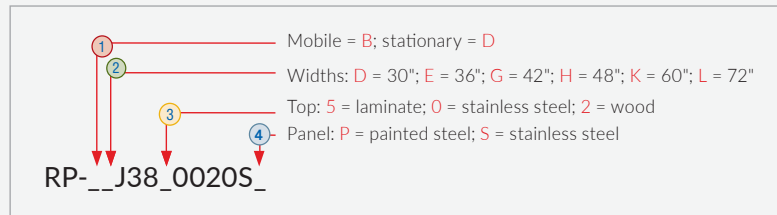
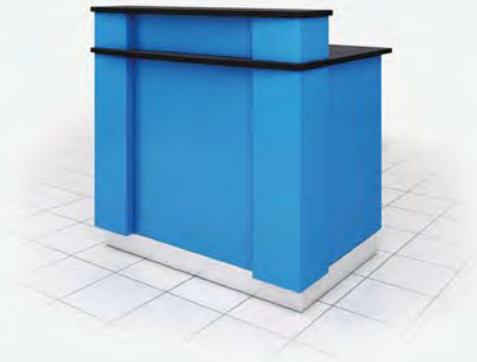

- NOTES: 1: Only available for 48"W, 60"W and 72"W desks.
 2: The shelf width varies according to the desk width. 24"W for a 48"W desk; 36"W for a 60"W desk; 48"W for a 72"W desk.
 3: 48"W desk = 24"W double doors; 60"W desk = 36"W double doors; 72"W desk = 48"W double doors.
 4: Available in 30"W only.
 5: Desks with doors cannot be mobile.

REAR VIEW

BASIC DESK

- Riser shelf



RP-__J38_0020S_

BASIC DESK WITH LCD MONITOR MOUNT

- Riser shelf with 1 power outlet and 2 USB ports
- LCD monitor mount
- LED light
- Full-width shelf
- Waste and recycling containers



RP-__J38_0040S_

DESK WITH CABINET

- Riser shelf
- 18"W cabinet with 4 drawers



RP-__J38_002RS_ (Note 1)

DESK WITH CABINET AND LCD MONITOR MOUNT

- Riser shelf with 1 power outlet and 2 USB ports
- LCD monitor mount
- LED light
- 18"W cabinet with 4 drawers
- Shelf
- Waste and recycling containers



RP-__J38_004RS_ (Note 1 and 2)

SERVICE ADVISOR DESKS

DESK WITH CABINET



- Riser shelf
- 18"W cabinet with 2 drawers and 1 roll-out shelf

RP-__J38_006RS_ (Note 1)

DESK WITH CABINET AND LCD MONITOR MOUNT



- Riser shelf with 1 power outlet and 2 USB ports
- LCD monitor mount
- LED light
- 18"W cabinet with 2 drawers and 1 roll-out shelf
- Shelf
- Waste and recycling containers

RP-__J38_008RS_ (Note 1 and 2)

DESK WITH CABINET, LCD MONITOR MOUNT AND SECURE STORAGE UNDER THE WORK SURFACE



- Riser shelf with 1 power outlet and 2 USB ports
- LCD monitor mount
- LED light
- 18"W cabinet with 2 drawers and 1 roll-out shelf
- Adjustable shelf
- Shelf
- Door with lock to secure personal belongings

RP-D_J38_012RS_ (Notes 1, 2, 3 and 5)

DESK WITH CABINET AND SECURE STORAGE UNDER THE WORK SURFACE



- Riser shelf with 1 power outlet and 2 USB ports
- LED light
- 18"W cabinet with 4 drawers
- Adjustable shelf
- Shelf
- Door with lock to secure personal belongings

RP-D_J38_010RS_ (Notes 1, 2, 3 and 5)

DESK WITH PRINTER SHELF



- Riser shelf with 1 power outlet and 2 USB ports
- Power feed panel under the work surface
- Printer shelf
- LED light

RP-_DJ38_0060S (Note 4)



Grimsby Ford (ON)

SERVICE ADVISOR DESKS

DOUBLE SERVICE ADVISOR DESKS



DESKS WITH CABINETS AND LCD MONITOR MOUNTS

- Gray laminate tops
- 2 riser shelves with 1 power outlet and 2 USB ports each
- 2 LCD monitor mounts
- 2 LED lights
- 2 cabinets (18"W) with 4 drawers each
- 2 shelves (24"W)
- Waste and recycling containers
- Stainless steel finishing panels

PRODUCT NO.	WIDTH
RP-C252004SS	96"

NOTE: This model number is effectively 2 x model RP-DHJ385004RS on [page 90](#), plus desk joining kit RP-K001S.



DESK WITH CABINET AND LCD MONITOR MOUNT COMBINED WITH DESK WITH PRINTER SHELF

- Wood tops
- 2 riser shelves with 1 power outlet and 2 USB ports each
- LCD monitor mount
- 2 LED lights
- 18"W cabinet with 4 drawers
- 24"W shelf
- Waste and recycling containers
- Printer shelf
- Power feed panel under the work surface
- Stainless steel finishing panels

PRODUCT NO.	WIDTH
RP-C221002SS	78"

NOTE: This model number is effectively model RP-DHJ382004RSS and RP-DDJ382006OS on [pages 90 and 91](#), plus desk joining kit RP-K001S.

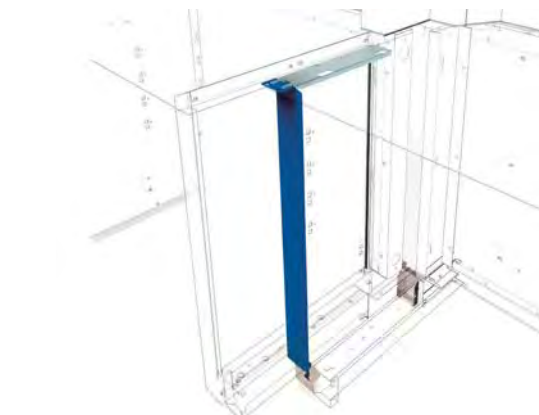

DESK JOINING KIT

- For joining two or more stationary service advisor desks together
- Suitable for side-by-side (linear) and offset configurations
- In offset configurations, the offset distance between desks is 8"
- One kit required per additional desk
- Includes finishing strips and attachment bars

PRODUCT NO.
RP-K001S

NOTE: Side-by-side desks and offset desks cannot be mobile.

SERVICE ADVISOR DESKS

ACCESSORIES



WASTE AND RECYCLING CONTAINERS

PRODUCT NO.	
RP46-01	Recycling Container
RP46-02	Waste Container



DOOR WITH LOCK TO SECURE PERSONAL BELONGINGS

PRODUCT NO.	
RP48	



ADJUSTABLE SHELF

PRODUCT NO.	
RP41	



PRINTER SHELF

PRODUCT NO.	
RP43-2121	



POWER FEED PANEL UNDER THE WORK SURFACE

PRODUCT NO.	
RP95	



PHONE AND NETWORK CABLE KIT

PRODUCT NO.	
RP95-01	



CABLE MANAGEMENT KIT

PRODUCT NO.	
RP95-02	



10 ADHESIVES CABLE TIES MOUNTING KIT

PRODUCT NO.	
RP95-03	

NOTE: To add accessories to preconfigured models, please contact Customer Service.



Oxford Dodge Chrysler (ON) - Front view

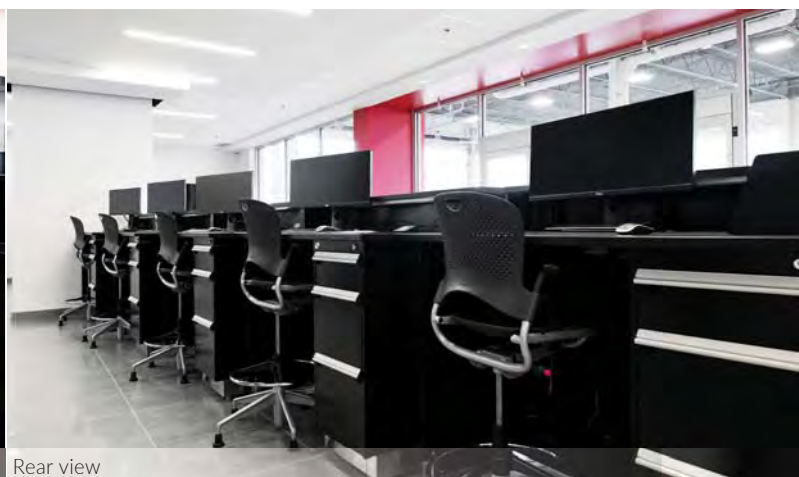

Rear view

PERSONALIZED PANELS

STAND OUT FROM THE COMPETITION!



Oxford Dodge Chrysler (ON)

Rousseau offers a personalization service for painted or stainless steel panels installed on GT workstations, service advisor desks and corner service counters.

Panels can be personalized with a logo, a name or even a slogan. Personalization is performed using digital printing with UV ink. It is a highly durable process that creates an immaculate finish and is easy to clean.

- Endless color possibilities
- For maximum impact, the design is always centered (vertically and horizontally)
- Existing panels can be replaced with new personalized panels

SEVERAL OPTIONS AVAILABLE



Digital printing with UV ink



Mirror finish to simulate a chrome finish

AVAILABLE FOR:

GT WORKSTATIONS



Order:
Stainless: RC42 + RZ99-43
Painted: RC41 + RZ99-43

CORNER WORKSTATIONS



Order:
Stainless: RS83 + RZ99-43
Painted: RS87 + RZ99-43

SERVICE ADVISOR DESKS



Order:
Stainless: RP96 + RZ99-43
Painted: RP99 + RZ99-43

SERVICE COUNTERS



Order:
Stainless: RS96 + RZ99-43
Painted: RS99 + RZ99-43