

nonlinearcircuits

DUAL LOW PASS GATE build & BOM

Dual Low Pass Gate - pretty much based on the Buchla version, except it uses the black box vactrol method seen in the Shat-noir Phaser and Noiro-ze VCF/VCA, also DG analogue switches are used for changing between filter and gate modes.

Please note the build pictures below when constructing to make the box fairly light-proof. A little bit of leakage does not seem to matter much but you could add a bit of black silastic sealant around the edges if you really want to, I have never bothered. When soldering the connector pins, use the SIP connectors, jumped across 1 or 2 pins (see pics) to ensure they are nicely perpendicular to the PCB. When soldering the PCB to PCB connectors, I press lightly on the PCB to help keep the connectors tight against the board.

The PCBs are 2mm thick with black soldermask to prevent light getting in.

Also, please note the pots go on the side of the PCB that has the pot symbol screenprinted, this is different to previous NLC PCBs.....just look at the pictures, if you have time and it isn't too much trouble.



BOM – The Tayda part numbers are given as examples, feel free to buy from your favorite retailer if you prefer.

VALUE	QUANTITY	DETAILS
220p	2	0805 OR 1206
1n	2	0805 OR 1206
2n2 = 2.2nF	2	0805 OR 1206
4n7 = 4.7nF	2	0805 OR 1206
100n	2	0805 OR 1206
1µF	2	0805 OR 1206
10µF	2	0805 OR 1206 25V rating or higher
1k	4	0805
4k7	2	0805
10k	11	0805
15k	4	0805
22k	2	0805
33k	2	0805
100k	12	0805
120k	2	0805
150k	2	0805
470k	2	0805
4M7	2	0805
SPDT toggle switch	2	on-on or on-off-on....if you want filter/gate mixed mode. Tayda: A-4567 or A-3187
20k trimpot	2	Tayda: A-2504
3V9 zener diode	2	size: SOD-80, mini MELF, LL34, DO-213AAthey are all same
DG202 or DG212	2	soic
TL074	2	soic
light dependent resistor (LDR)	4	SEE NOTES #5. THESE GO ON THE BOTTOM OF THE UPPER PCB
LED	2	3mm or 5mm, diffused Red, green or yellow. THIS GOES ON THE BOTTOM OF THE UPPER PCB
100k (B) pot	6	Tayda: A-1848
Eurorack 10 pin power connector	1	Tayda: A-198
Schottky, power rectifier or 10R, optional - for reverse voltage protection...or not	2	SMD, Schottky (best option) or standard power rectifier diode 50-600V 1A or more, dot on PCB indicates CATHODE (stripe on component) Or use a resettable fuse or just a 10R. SEE NOTES #2
3.5MM SOCKET Kobiconn style	8	Tayda: A-865 or preferably get Thonkiconn Jacks (PJ301M-12) from Thonk or Modular Addict
10 Pin 2.54mm Single Row Pin Header Strip	7	Tayda: A-197 (cut to size)
10 Pin 2.54mm Single Row Female Pin Header	7	Tayda: A-1306

Additional notes:

1. Capacitors can be 0805 or 1206, whatever is easiest to find.
2. Some power diodes: PMEG2005EGWX SCHOTTKY RECT, AEC-Q101, 20V, SOD-123, PMEG2005EH DIODE, SCHOTTKY, 0.5A, 20V, 1N400x or S1JL or similar
3. The resistors, caps and transistors are cheapest from Tayda. Diodes from Mouser/E14/Farnell/etc.
4. Join the Nonlinearcircuits Builders Guild on FB:
<https://www.facebook.com/groups/174583056349286/> and ask questions there if you have any. If you prefer not to FB then email is fine.
5. After testing 30+ of these with different LDRs, I had some pretty mixed results. **GL5516** seem to be fine for filter & gate. Some GL5539 were not good for the filter and some were, tho maybe you could tweak the caps to get it

squealing (pita imo). GL5549 work well for the filter but about 50% won't get unity gain in Gate mode. Also tried **Advanced Photonix NSL 19M51**, which were maybe best for filter AND gate. You can find LDRs on ebay; about \$4 for 100, search for the GL codes just given. Be prepared to change out the LDRs, tho should be safe with GL5516 or NSL19M51...or probably whatever you find.

6. when soldering on the pins, use the SIP connectors to hold them on straight. This pic below is of the Shat-noir but the method is the same.

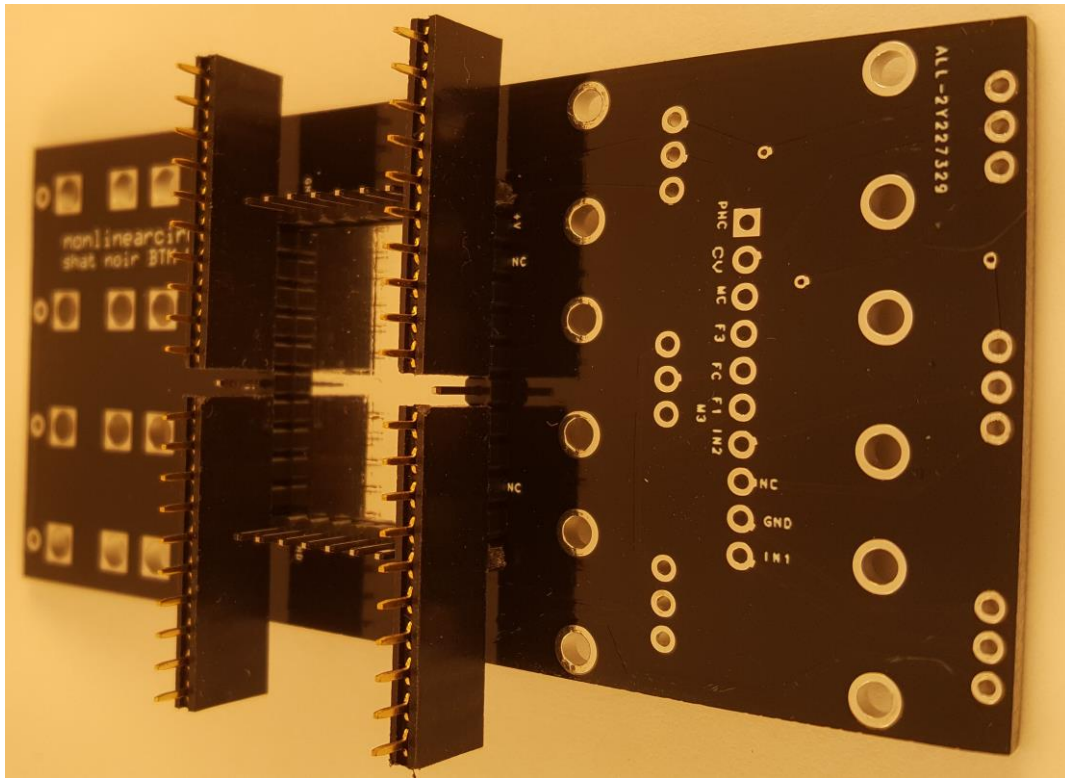

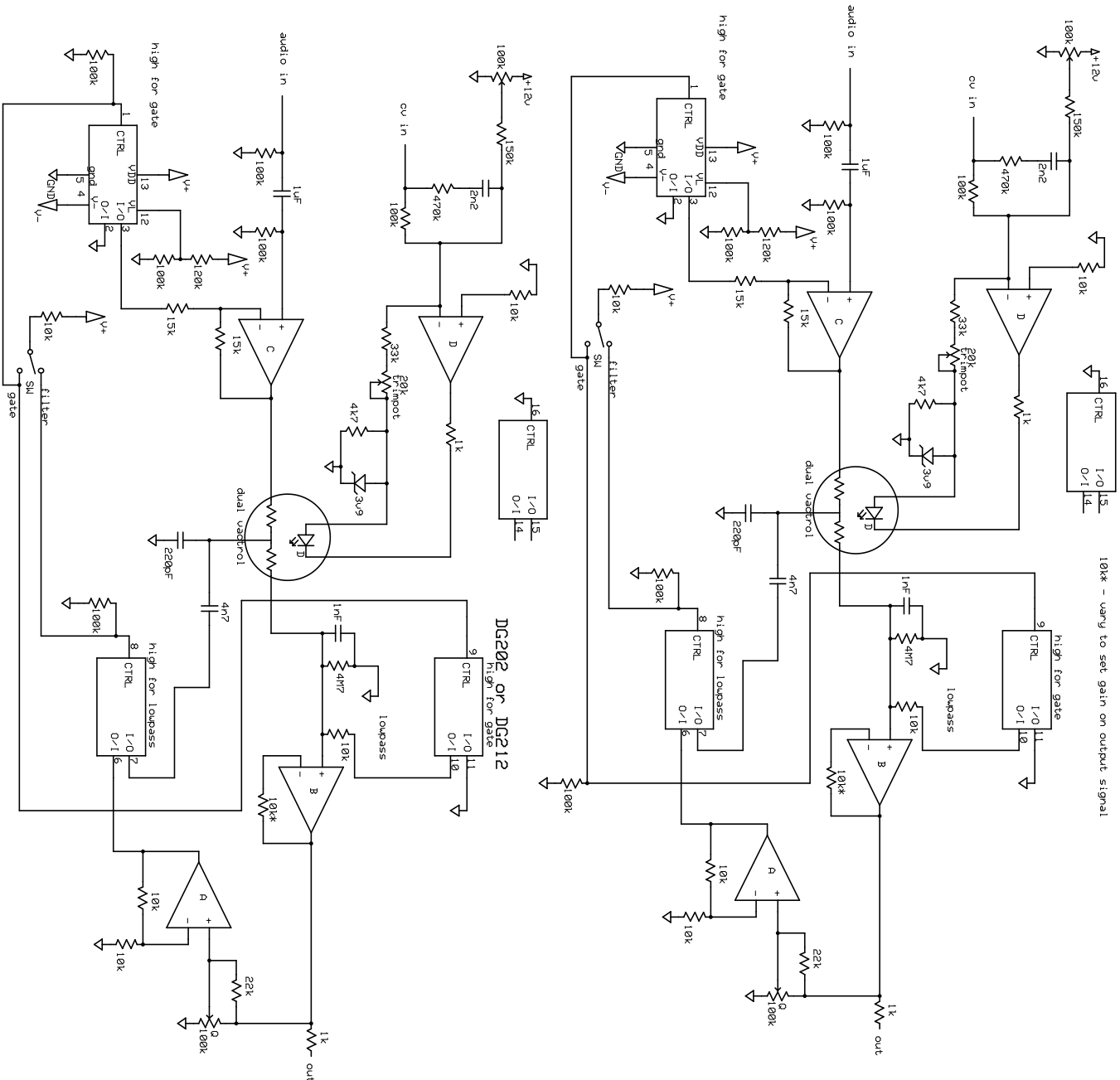

non linear circuits

LPG BBX 1

Rev 1.1
18/8/2018

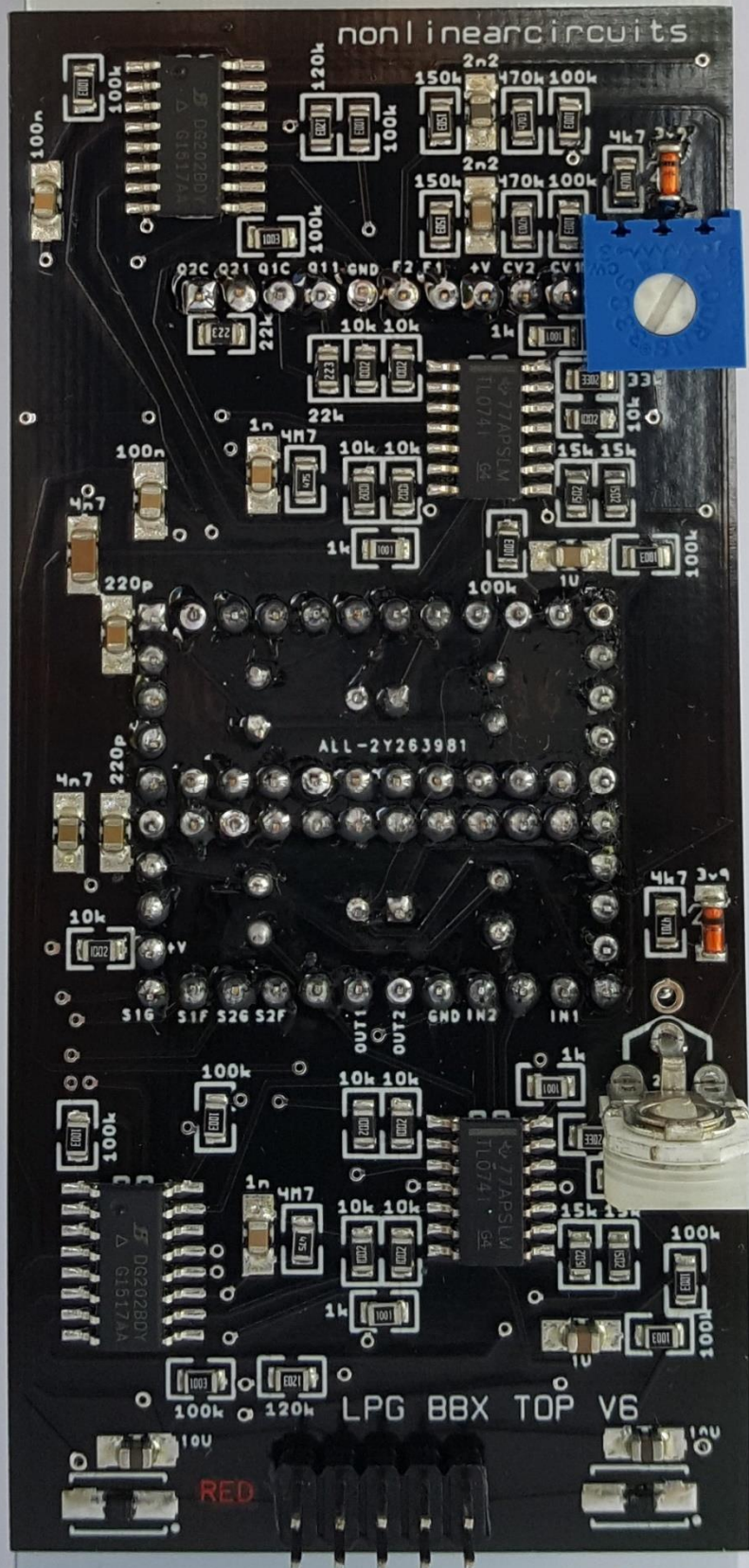

non linear circuits

ALL-2Y263981

LPG BBX TOP V6

RED

