

Go2 AIR

Go2 PRO

使用手册

User Manual

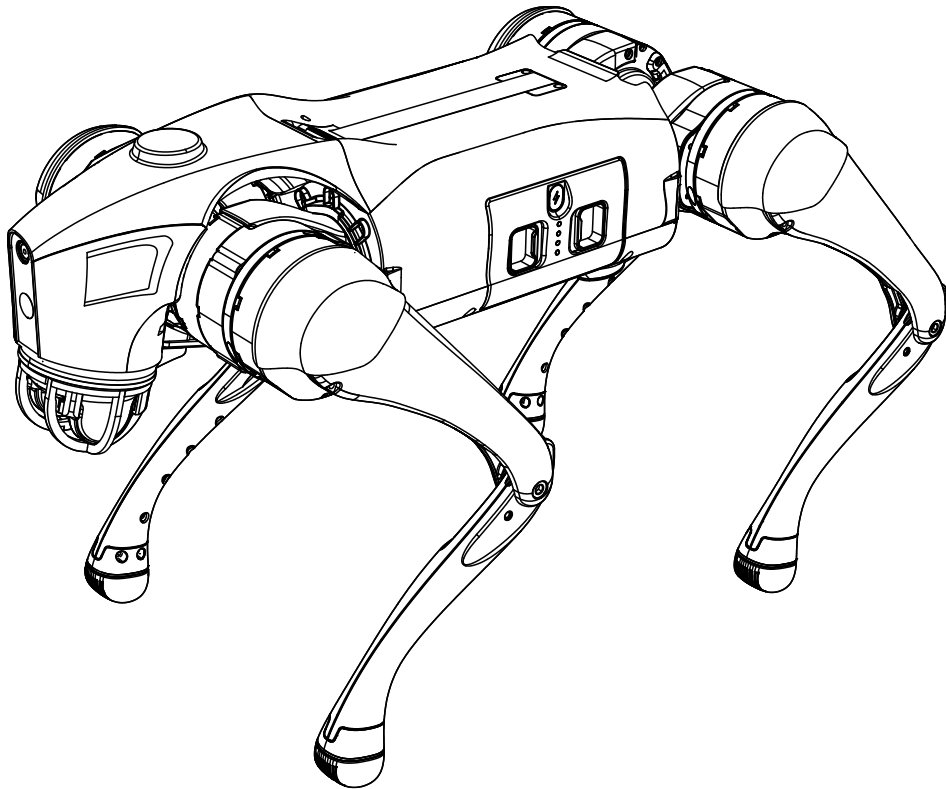

Unitree

本产品为民用机器人产品，请各位用户不要危险性改造和使用机器人。

请访问宇树科技官网了解更多产品相关条款与政策，请遵守各地区法律法规。

This product is a civilian robot. We kindly request that all users refrain from making any dangerous modifications or using the robot in a hazardous manner.

Please visit Unitree Robotics Website for more related terms and policies, and comply with local laws and regulations.

Catalogue

Catalogue	1
Safety Instructions	2
Product Overview	3
Function Diagram	4
How to charge.....	6
How to use your robot.....	8
Learn about shipping box	8
Prepare your robot.....	9
Start up Go2	9
Switching off Go2.....	10
Activate your Go2.....	11
Operate your Go2.....	13
Explanation of abnormalities	15
Cautions.....	16
Dalily Care and Maintenance	17
Disclaimer	18

Safety Instructions

Go2 is a globally high-performance, consumer-grade interactive quadruped robot that requires practice to master the skills of manipulation.

1) This product is not a toy and is not intended for use by persons under the age of 14. Keep out of reach of children and be careful when operating in the presence of children.

2) It is your responsibility to be aware of the laws in your area and to comply with them.

3) This chapter is an introductory chapter for new users to manipulate robots. New users can quickly master how to use the handle to control the robot to show excellent movement performance by reading this section.

4) Do not lift the robot after it is powered up to avoid the robot performing unanticipated actions that could cause damage to itself !

5) Go2 is a purely electric quadruped robot with certain anti-jamming, but the energy density of the motor is much lower than the hydraulic pressure. Do not push the robot suddenly and vigorously, nor to kick the robot, so if the robot falls and is damaged due to a sudden and strong push or kick, it will not be covered by the warranty.

Requiring Environment:

1) Please do not run the robot in an electromagnetic interference environment. Sources of electromagnetic interference include but are not limited to: high-voltage power lines, high-voltage transmission stations, mobile phone base stations, and television broadcast towers.

2) Please do not run the robot in the Wi-Fi signal interference environment. Wi-Fi signal interference is usually caused by co-channel interference. In case of interference, be sure to turn off some or all Wi-Fi signal sources of other wireless devices before using the remote control to operate the robot.

3) Please keep it under control in the users' view when using the robot and keep the robot maintain a safe distance of at least 2 meters from obstacles, complex ground, crowds, water, and other objects.

4) Run the robot in 5°C -35°C with good weather condition. Do not run in inclement weather, such as fog, snow, rain, lightning, sandstorms, windstorms, tornado weather, etc.

5) The robot is not waterproof, so do not run it with water on the ground, in rain, snow, or wet conditions! The robot is not dustproof, please do not run it on gravel floors, dusty environments!

6) The legged robot has certain requirements for the ground on which it walks. Do not use the robot on very low friction ground, such as ice. Do not use the robot on soft ground, such as thick spongy ground. If the robot is used on smooth ground, such as glass and ceramic tile, the users need to control the robot for movement carefully and smoothly, avoid violent movement, and reduce the walking speed of the robot to prevent the robot foot from slipping and falling.

Preparation before use:

1) Only Use Unitree Robotics authentic parts and ensure that all parts are in good working condition.

2) Ensure that the firmware has been updated to the latest version.

3) The users ensures that he or she is not operating the robot while intoxicated, under the influence of drugs, and unable to concentrate.

4) Be familiar with the characteristics of each gait mode. Be familiar with the emergency braking method of the robot in case of instability / loss of control.

5) Ensure that there are no foreign matters (such as water, oil, sand, soil, etc.) inside the robot and its components.

6) Ensure that the surface of the robot's camera and LIDAR are free of dust and are not surrounded by obstructions.

Product Overview

The whole robot

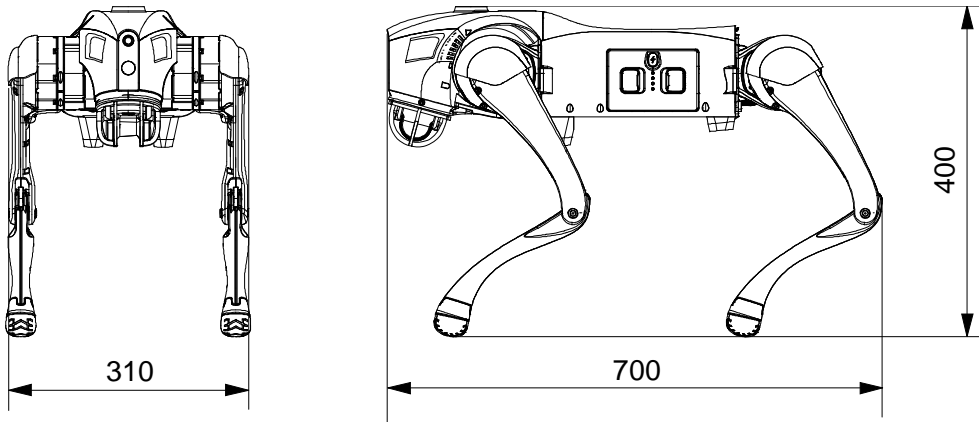

Generic Accessories

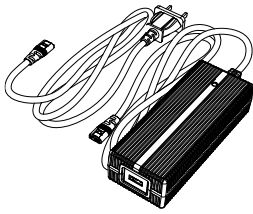

Charger x1

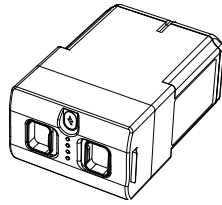

Battery(8000mAh)x1

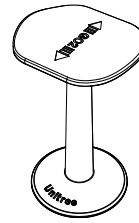

Display Stand x1

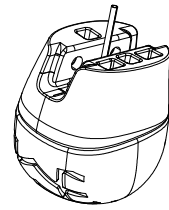

Foot end componen x4

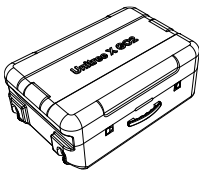

Dedicated luggage x1

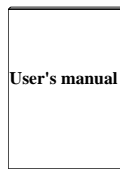

User's manual x1



Certificate x1

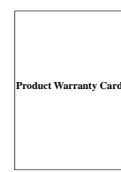

Product Warranty Card x1

Product Warranty Card



Companion Remote control x1



Type-C Cable (1m) x1



Please check whether the items in the luggage are Please check the number and condition of the items in luggage. Pictures in the manual for reference only, specific products in kind prevail. Accessories may vary from different models, please refer to the actual model.

Function Diagram

Unitree's new upgrade interactive bionic quadruped robot Go2 has 12 degrees of freedom (composed of 12 aluminium alloy precision joint motors), and employs force-control technology to provide composite control of force and position for each joint, in order to achieve force-control of the whole machine to achieve excellent motion performance. The whole robot is made of aluminium alloy and high-strength engineering plastics, which greatly improves the stability and reliability of the machine dog; the maximum running speed can reach 5m/s (measured in the laboratory). Equipped with 4D LIDAR L1 with 360°x90° hemispherical super wide-angle sensing, which can help Go2 to achieve no blind area coverage. It reaches the leading level at home and abroad both in terms of structure, motion performance, environment perception, and side following.

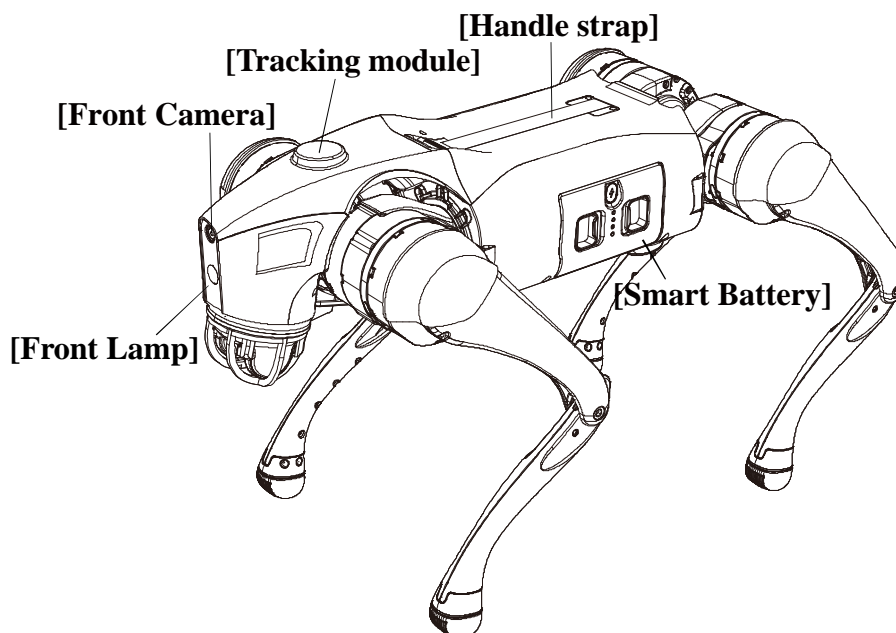
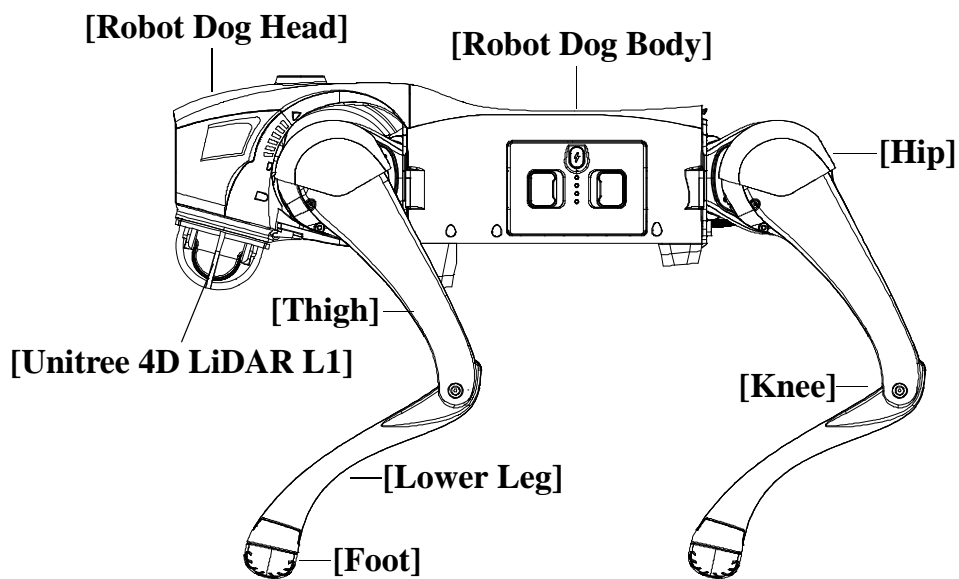

Go2's Function Differences

Function	AIR	PRO
Basic movement and actions	●	●
Condition Indication	●	●
Intelligent OTA Upgrades	●	●
Unitree Go App	●	●
Wi-Fi 6 / Bluetooth	●	●
Intelligent avoidance	●	●
4G Image Transmission	○	●
Intelligent Side-follow System	○	●
Voice Interaction	○	●
Auto Retractable Strap	○	●

1) Status Indication

Go2's head indicator light can emit different lights to show the current working status of the robot and the current operating system, please refer to the following table to learn more about the operating status indicated by different flashing modes and colors:

Color and Flashing	Meaning
Flash in green	Switching on
Permanently on in green	Powered on, default obstacle avoidance on
Permanently on in blue	Obstacle avoidance closure
Permanently on in yellow	Range mode
Permanently on in purple	Accompanying mode on state
Low flash rate in blue	Motor & IMU calibration in progress
Low flash rate in yellow	Low battery warning, will automatically crouch down within 10 minutes
Low flash rate in red	System abnormality, boot failure, hardware failure, need to contact after-sales service.
Fast flash rate in red	Motor & IMU calibration failed
Permanently on in white	Head indicator light



Light priority: companion mode on (purple light always on)>endurance mode (yellow light always on)>obstacle avoidance off (blue light always on)

2) Intelligent Avoidance

Equipped with Unitree's self-developed 4D LiDAR L1 with 360°×90° hemispherical ultra-wide-angle perception, boasting ultra-low blind spot, the minimum detection distance is as low as 0.05m, which can help Go2 to achieve a blind spot-free coverage, real-time access to three-dimensional information about the surrounding environment, and in the process of travelling according to the radar data to carry out intelligent avoidance (only support forward obstacle avoidance), to avoid collision and ensure the safety of the robot and the surrounding environment.

3) Intelligent Side-follow System 2.0 (ISS2.0) (Not supported by AIR)

By adopting the new wireless vector positioning and control technology, the positioning accuracy is technically upgraded by 50%, the remote control distance is over 30m, and combined with the optimised obstacle avoidance strategy, it can make the robot better traverse complex terrain.

4) Voice Interaction (Not supported by AIR)

Supports voice interaction and commands and built-in voice recognition module, and converts human language into computer language to communicate with the main chip, so as to control the robot and achieve human-machine language interaction. Reaches voice interaction response at millisecond level, using the industry's advanced voice recognition technology with high recognition accuracy, fast literacy.

5) App remote image transmission

With the new Unitree Go App, it provides omni-directional ultra-wide image transmission, real-time viewing of shooting images, built-in 4G and eSIM (not supported by AIR) for more stable connection and remote control. It intelligent OTA upgrades, which makes the operation in ultra-vision range as simple and convenient as being in the field.

6) Auto Retractable Strap (PRO version only)

The Go2-PRO version has a new upgraded auto retractable strap with a built-in bi-directional tensile winder, through which the height of the hand strap can be adjusted according to the user's needs. The auto retractable carry handle belt is driven by motor to drive the carry handle belt to extend/contract, which makes Go2 more simple and beautiful in appearance.

How to use the auto retractable strap: After Go2 is powered on, push the retractable button backward, you can pull the strap out to the right position to fix it, push the retractable button forward, the strap will be automatically retracted.

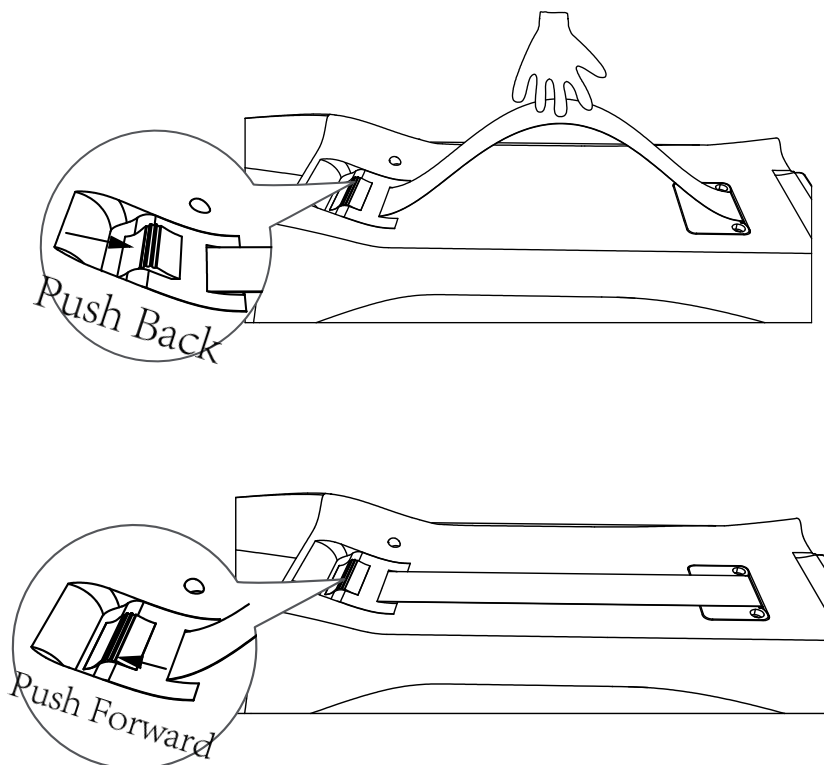

How to charge

Due to reasons such as self-consumption of the battery during transport and storage, it is normal to have a low or empty battery when using it for the first time, and charging can be done in the following way.

1) Charge the battery

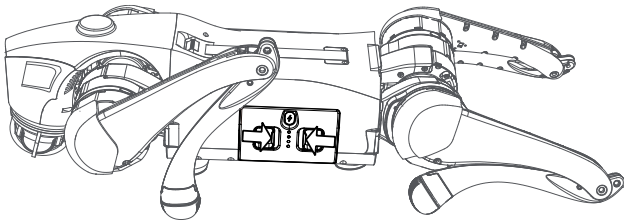

Remove the battery from the body
(Press the two snaps of the battery pack)

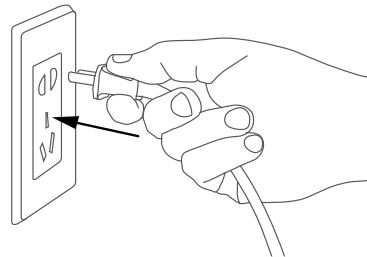

Charger input AC power
(100-240V, 50/60Hz)

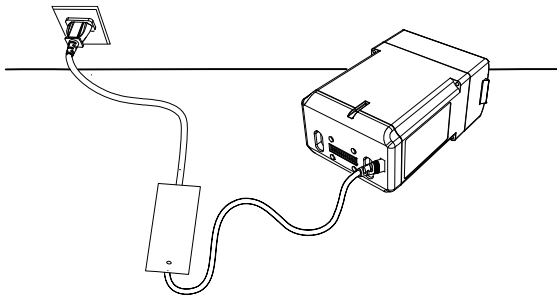

Connect the Go2 battery

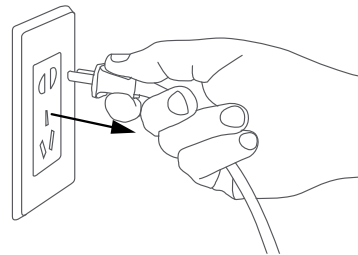

Manually disconnect the power when fully charged

2) Companion Remote Control

When the battery indicator light of the companion remote control shows that the battery is low, you should connect the companion remote control to the charger as shown in the figure below:

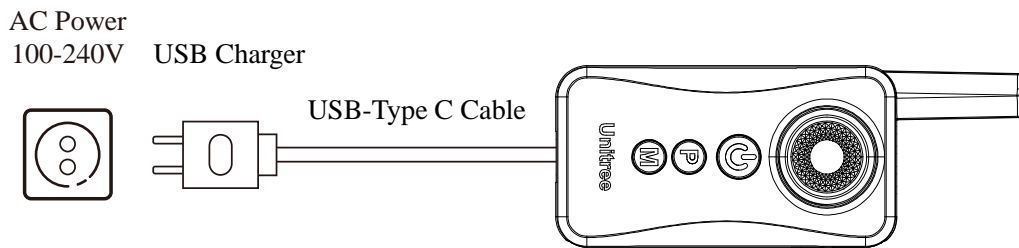

a) We recommend you to use a 5V/1A USB charger which meets FCC/CE standard.

b) The power indicator light will flash at 1Hz (1 second/time) in charging status and indicate the current power level.

c) When the power indicator light is all off it means the battery pack is full, please remove the charger to finish charging.

How to use your robot

Learn about shipping box

The picture is only used to illustrate the placement of parts, please refer to the received content. The picture below mainly takes Go2-PRO as an example, the accessories of different models will be different, please refer to the actual model.

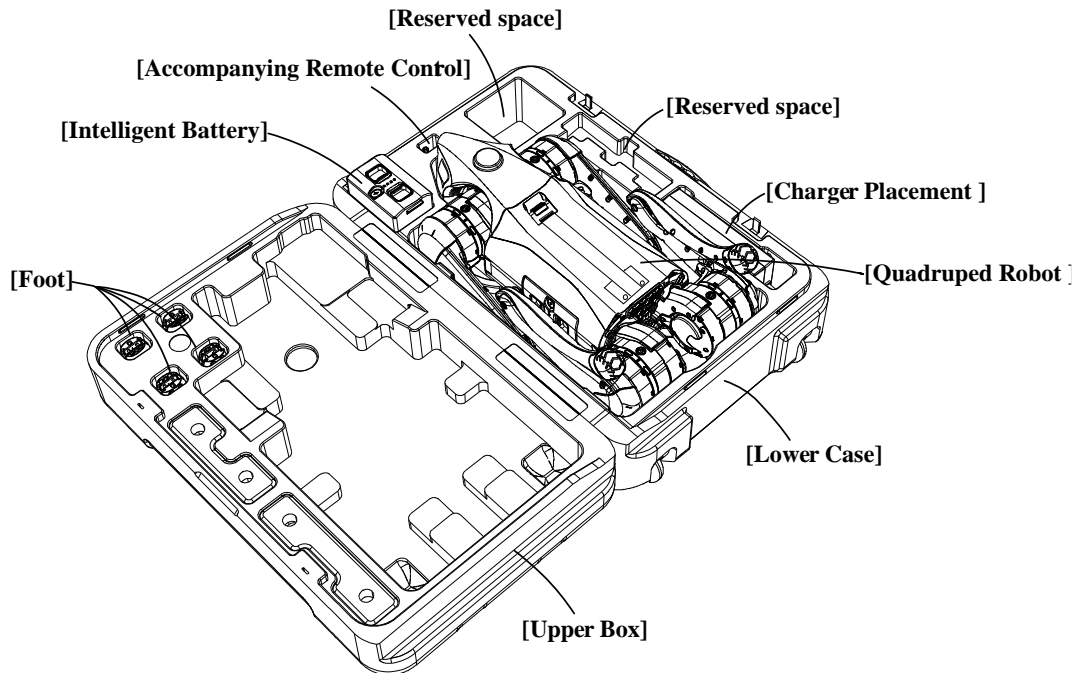

Unpacking

Place the box face up on a flat surface, then open the upper box. Lift the robot out of the box by using the strap, and remove the accessories from the box in order. After learning how to use the robot correctly, place the quadruped robot flat on a level surface and prepare it for power-up.

Packing

Preparation for packing: Rotate the legs of the quadruped robot to the position shown in the picture (rear leg retracted step: rotate the rear leg hip motors so that the rear thighs are placed in the position as the picture shows, and at the same time retract the rear lower legs to the position shown in the picture).

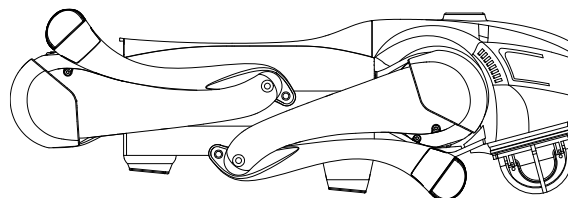

After completing the preparatory work for packing, load the quadruped robot into the lower box in the direction shown in the picture (pay attention to the head of the quadruped robot to be stuck into the head placement in the process). After the quadruped robot is loaded, put the battery and charger that come with the shipment into the corresponding positions in the transport box to ensure that none of the above parts will fall off when the upper box is closed.

Prepare your robot

1) Installing Battery Packs

Lay Go2 on a flat surface, insert the battery pack into the battery packs from the side of the robot, pay attention to the direction of installation, with the power switch button facing upwards. If the battery pack cannot be fully inserted, please adjust the direction of the battery packs and do not press forcibly to avoid damage to the battery interface and buckle. When you hear a "click" sound, the battery pack installation is complete.

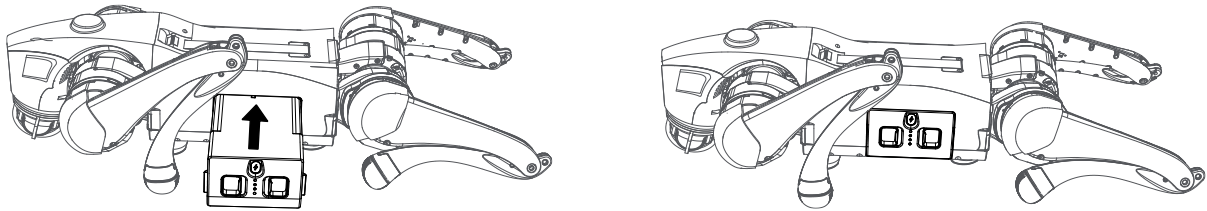

2) Body Placement (Important !)

Horizontal start-up: Please make sure that the robot is placed on a flat surface before start-up, that the robot's abdominal support pad is flat on the ground, that the robot's body is lying on the ground horizontally without any tilting, that the robot's lower legs are in a fully retracted state (as shown in the picture below), and that all four joints and the ends of the feet are placed on the ground flatly to make sure that the robot's thighs and lower legs are not pressed down by the robot's body.

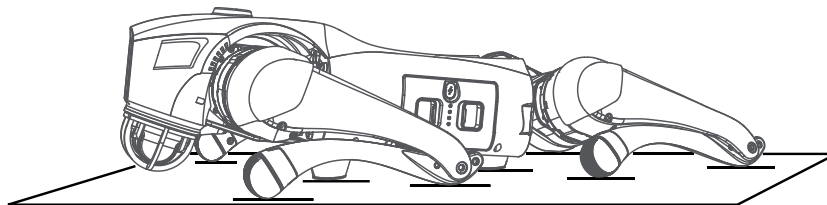

Start up Go2

After the robot is placed according to the requirements, start it up according to the following steps: Firstly, press the Go2 power switch button briefly for 1 time, then press the power switch button for 2 seconds or more, then Go2 can be started up. During the startup process, the Go2 head indicator light flashes in green. And wait for 2 minutes, the head indicator light is in green permanently, and the body is parallel to the ground, then the robot is started up.

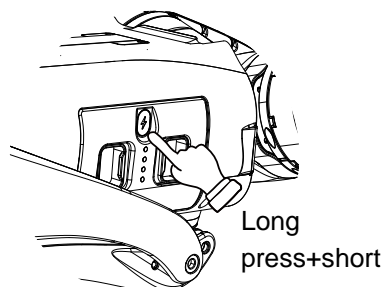

- If the start-up fails, please check the body placement carefully.
- The Go2 may fail to start up if the legs are stretched outwards or if the legs are pressed inwards.
- Hand may be pinched at the motion joints, please be careful!

Switching off Go2

Before switching off, please make sure that the robot is standing on a flat surface, and make sure that the robot is in a static standing state (the robot body position is in the initial state on the power-up, the body is horizontal, and the state is in the static standing state).

1) Operate the robot into the prone state;

2) After the robot enters the prone state, short press the power button then long press the power button for 2 seconds to switch off the robot.

After switching off the robot, please follow the body placement requirements and position Go2's big and small legs and hip joints to prepare for the next start-up. If you do not use Go2 for a long time, please remove the battery pack and follow the packing steps to put Go2 into the dedicated luggage.



- Please make sure that the robot turned off in a damping state, otherwise the robot will fall heavily on the ground after it is turn down and powered off, which may cause damage to the robot body and certain potential hidden dangers! If the power on fails, please check if the robot body is placed correctly.

Activate your Go2



The robot requires activation for first time use, please scan the QR code on the left side to install Unitree Go App, and follow the App prompts to activate Go2 and complete the inbuilt teaching. During the activation process, please turn on your bluetooth on your mobile phone and bring your phone close to Go2 to ensure real-time bluetooth communication. After successful bonding, you can start to use the robot.

- 1) Please sign up / log in after installing the App
- 2) Start up Go2: head indicator green permanently, body parallel to the ground

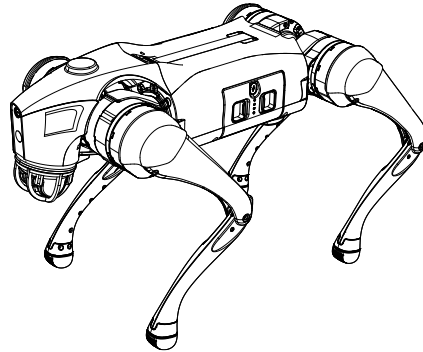
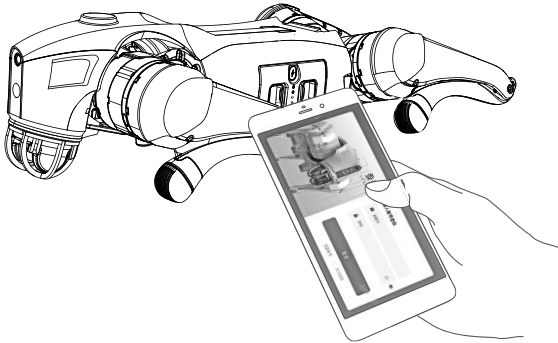

- 3) **Add robot:** Home page -add robot-open Bluetooth to connect your Go2-set robot information.

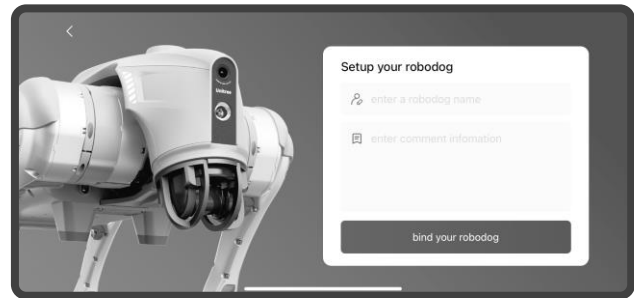
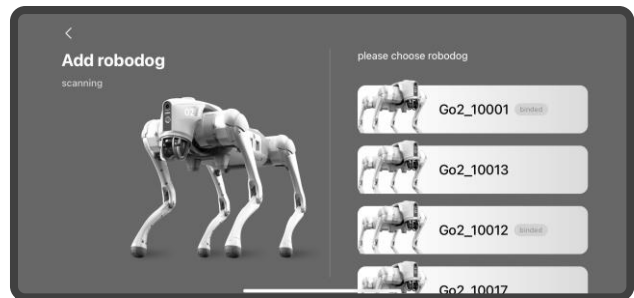
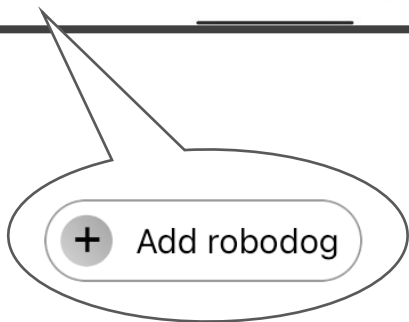
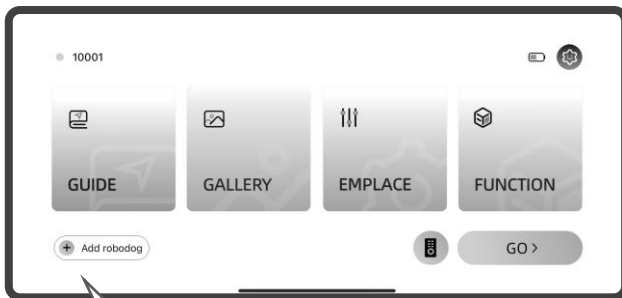

- 4) **Bind the robot:** you can choose AP router mode and Wi-Fi connection mode to connect, you can learn the built-in tutorial to quickly master the operation skills after successful connection .

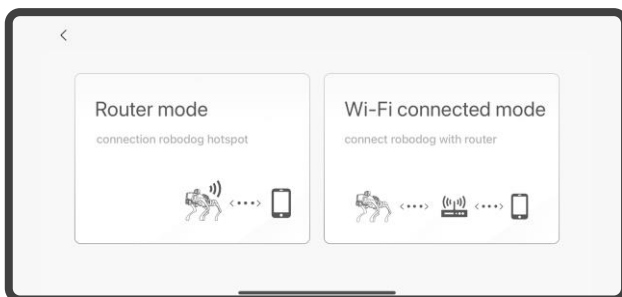

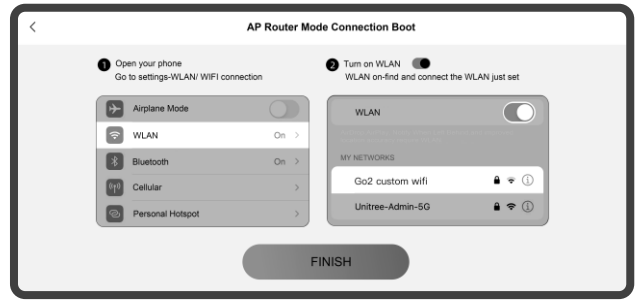
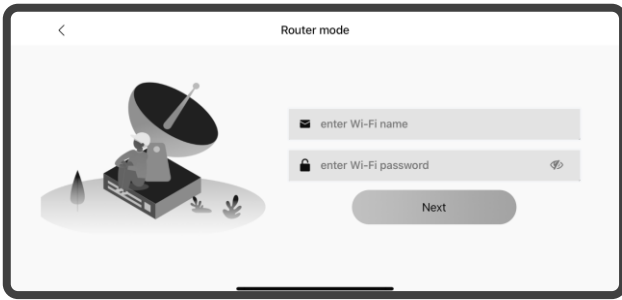

How to change the account binding?

Home page- Settings - Robot Settings - Switch Connection, choose to click Unbind, you can unbind the bound robot dog. After the robot dog is unbound, it can be bound by other users.

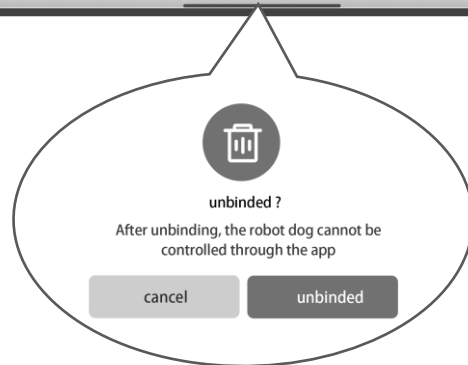
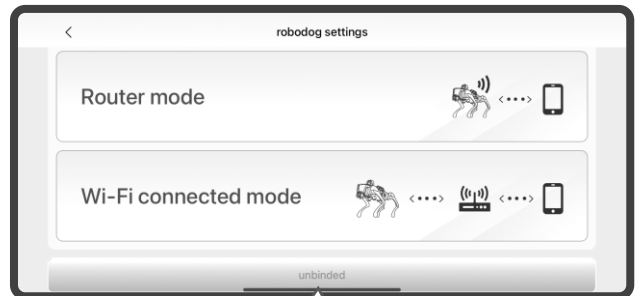
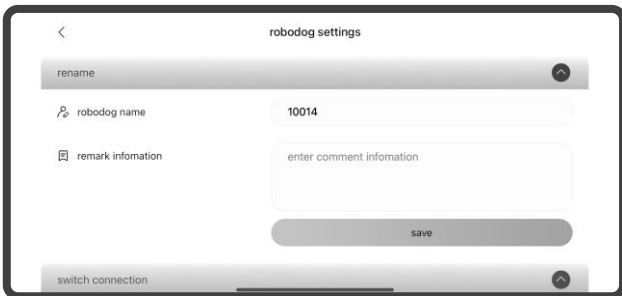

- ⚠ Please keep your mobile phone's bluetooth on during connection!
- Bluetooth connection error: Unitree Go App needs to get Bluetooth permissions, please open Unitree Go Bluetooth permissions in the App.
- If you forget your bound account, or if you lose your account, please contact the relevant Unitree staff !

Operate your Go2

1) Use the Unitree Go App to control your Go2

After completing the built-in tutorial in the Unitree Go App, you can use the app to control your Go2 as you want.

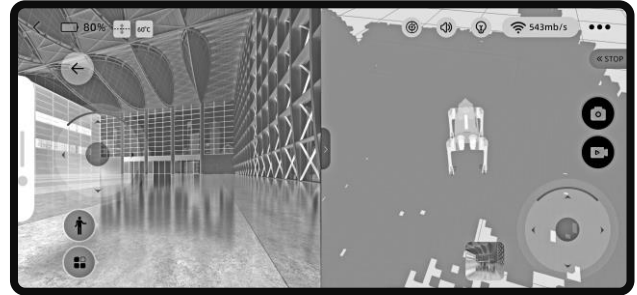
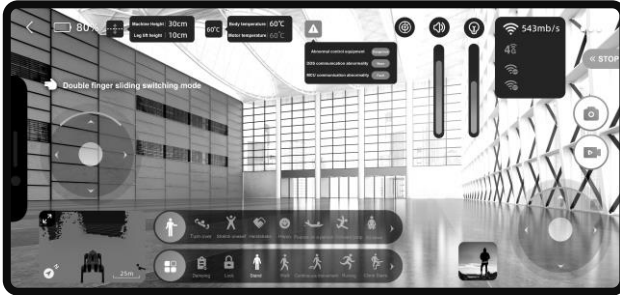

2) Use voice control Go2 (Not supported by AIR)

Go2-PRO has a built-in voice module. You can use the following voice commands to control Go2 to complete the corresponding actions.

Type	Phrase	Voice response	Corresponding action
Wake up	Hey Benben	I'm here.	
Command word	Turn up the sound	Yes sir.	Turn up the volume.
Command word	Turn down the sound	OK sir.	Turn down the volume.
Command word	Show me a dance	OK, let's dance!	Do dance moves.
Command word	Wiggle Butt/ Twist your body	No problem.	Shake.
Command word	Bow with hands	Wish you good luck!	Stand up and bow.
Command word	Lock	Yes, sir. It's done.	Stop movement and lock.
Command word	Unlock	OK, now I can move.	Unlock.
Command word	Move forward / go ahead	OK sir	Unlock and activate sport mode to advance 2s.
Command word	Climbing mode / Start climbing	I'm climbing now.	Activate stair climbing.
Command word	Running mode / Start running	I'm the Flash.	Start running.
Command word	Show me love	I love you	Show your heart.
Command word	Pushup	I'm so strong!	Squat and stand up four times in a row.
Command word	Roll over	I'm rolling	Roll.
Command word	Stretch yourself	What a sunny day!	Stretch
Command word	Shake hand	No problem	Stop movement and lift front leg to shake hands (2s).
Command word	Lie down	I'm tired/I'm sleepy	Lying down.
Command word	Stand up	Let's go!	Return to standing and lock out.

.....



● Visit the Unitree Go App-Go2 Voice Phrase for more !

3) Use the companion remote control to control Go2 (Not supported by AIR)

Before powering on, the companion remote control should be fixed in the position as shown in the picture. After the robot is powered on successfully, you can use the companion remote control to control Go2, the operation steps are as follows:

Step 1: Wear and start the companion remote control.

a) Buckle the remote control to the right side of the human body on the belt, stand on the left side of the robot, and keep your torso facing the same direction as the robot.

b) Short press the power button of the companion remote control, when the indicator light is on steadily the startup is finished, at this time the remote control is in rocker mode.



Step 2: Start the side-following mode (Important step)

a) Short press the M button twice to start the slow auto-following mode, the maximum speed at 1.5m/s.

b) In slow auto-following mode, short press M button twice to enter fast auto-following mode with maximum speed at 3.0m/s.

Step 3: Turn on/off obstacle avoidance function

Short press L2 button twice to turn on the obstacle avoidance; short press once to turn off the obstacle avoidance.

Step 4: Switch off the auto-following function

a) Short press M button once: stop following and enter the rocker control mode.

b) Switch on the rocker: Toggle the rocker to stop the follow mode immediately and enter the rocker mode.

c) Switch off: Long press the power button of the companion remote control for 2 seconds to switch off.

d) Horizontal Placement: Place the companion remote control horizontally.

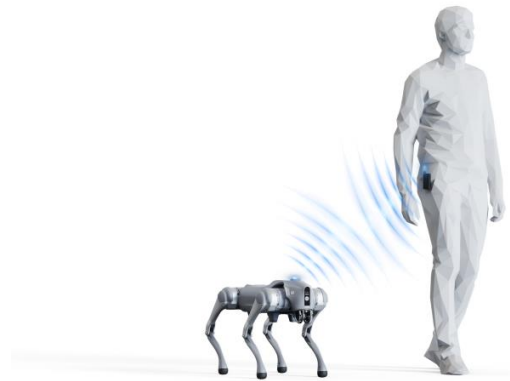

Other operating instructions (For adjusting the machine)

a) Rocker control: When the companion remote control enters the rocker mode, the robot movement can be controlled by the rocker. Using the rocker control mode, the remote control can be taken off the belt for control. If you need to continue to use auto-follow after the remote control is taken off, you need to put the remote control on and then turn on the accompaniment.

b) Stand up, Down, Damped Mode: Short press P button 2 times consecutively, the robot switches cyclically between Down, Damped and Stand up modes.

c) Side roll: When the robot rolls over on its side, press P button and hold for 1 second to resume standing.



Auto following precautions:

- Can not be too fast (less than 1.5m/s in slow mode, less than 3.0m/s in fast mode).
- The companion remote control can not be placed too high (within about -10cm~120cm height difference from the robot's head).
- When conditions allow, choose a more open route to minimise the triggering of the robot's own autonomous avoidance function.
- App can not control the robot at the same time with the companion remote control, if you need to use the companion remote control, please do not use the app to control the robot.
- When using, please keep the robot in the line of sight control, with make the robot to maintain a safe distance of at least 2 metres.

Explanation of abnormalities

When using Go2 quadruped robot, robot abnormalities may occur. Most of the abnormalities are controllable (with solutions), customers should not panic when encountering these problems, read the following content and follow the following steps to solve the problem.

If you have any questions, please contact the official technical support of Unitree:

support@unitree.cc

1) Go2 does not stand up after switching on with head flashing red light

Go2 head red light flashing slowly, this means power on failure, carefully check the robot power on placement, re-position and then reboot. If the robot still fails to stand up, there may be system abnormality or hardware failure, then you need to contact Unitree official technical support to troubleshoot the problems.

2) App connectionerror error

If using AP connection mode, please check whether the mobile phone is connected to the AP hotspot issued by Go2.

If using Wi-Fi connection mode, please check whether the connected Wi-Fi network is normal and can connect to the external network.

If using 4G connection mode, please check the current traffic situation under [Settings]->[Mobile Network] of the App to ensure that the 4G IoT card connects to the external network.

3) Can't use the App to control Go2?

Go2 cannot be controlled by companion remote control and App can't control Go2 at the same time. If you want to use App to control Go2, please exit the side-following mode first. Press the power button for 2 seconds to switch off the remote control. Then you can use the App to control Go2.

4) Abnormal standing posture after switching on

After Go2 is switched on, if walking posture is abnormal and it is easy to fall down, etc, and restarting the robot cannot solve the problem, at this time, you need to re-calibrate the robot joints according to the relevant steps in Unitree Go App.

Note: Go2 has been calibrated in factory default settings, please do not calibrate the joints for normal use! Please consult Unitree's official technical support to determine whether you need to re-calibrate the joints after Go2 has an abnormal situation!

App joint calibration entrance is [Settings]->[Data]->[Machine Dog]->[imu Information]->[Calibration].

5) Radar stops rotating when meet external force

Normally, when relieving external force, the radar will automatically resume rotation. If it still can't work, you can try to make the radar roll by fiddling with your hand. If the problem still remain unsolved, please try to restart Go2. If it can't be solved after restarting, you can check the malfunction details on the app, and consult with Unitree's official technical support.

6) Restore Factory Settings

The reset button is on the back of Go2, which can complete the factory setting of Go2. The operation method is as follows: press the reset button (long press, do not release) in the power off state, power up the Go2 battery (short press + long press for 2 seconds), then you can reset the factory settings. Wait for the yellow light blinking after powering up Go2, at this time you can release the reset button and wait for the green light on the head of Go2, the system reset is successful, it takes about 30 minutes.

Cautions

1) Please make sure that the robot is lying down for switching off, otherwise the robot will fall heavily on the ground after switching off and powering off, which may cause damage to the body and remain certain hidden safety hazards!

2) When standing up, when the ground friction is insufficient or the robot's feet are not reliably supported, please do not operate the robot strenuously to adjust its posture (including pitching, rolling, yawing, fuselage height adjustments, etc.), otherwise it may cause the robot to fall down.

3) Please walk the robot on flat terrain. If you are walking on ground with low friction, do not operate the robot strenuously, otherwise it may cause the foot end to slip and fall.

4) The rated endurance of the robot is about 1-2 hours with no load static standing and upright walking alternately. It depends on the actual operating conditions of the robot, such as walking at a faster speed for a longer period of time, drastically adjusting the body attitude for a longer period of time while the robot is standing, standing with the robot legs bent, running with a load, walking at a lower body height, and terrain with appropriate undulations and slopes, etc., which will reduce the endurance time. (Lower body height and more knee bends place a greater burden on the motors and therefore increase power consumption significantly earlier and are accompanied by motor heating).

5) Because the levels of proficiency of the operator are different. To safety reasons, it is not currently recommended that robot walk stairs higher than 16cm, otherwise it is likely to trip over the foot due to improper operation. When encountering undulating ground, the operator should also be careful and reduce the speed of the robot. (AIR version has a maximum climbing drop height of 15cm).

6) Go2 is rated for a positive climbing angle of less than or equal to 40°. When a larger climbing angle is used (approximately equal to or greater than 40°), the robot body is likely to drift sideways, and direct turns on slopes with a large gradient are likely to destabilise the robot; reduce walking speed when climbing; proper control by the operator is required. (Maximum slope is 30° for AIR version).

7) Go2 can reach a maximum speed of 3.5m/s on flat terrain. (Maximum speed 2.5m/s for AIR version).

8) The robot foot end is a consumable item and a spare foot end will be included with the delivery. Especially walking on relatively rough ground, it will be worn out seriously. If there is obvious foot pad abrasion, damage, or loud noise when the robot walking on the ground, please replace the foot end in a timely manner, so as to avoid the damage to foot and malfunction of the robot movement.

9) It is forbidden to use the robot on the occasions where the terrain is complicated, the ground is wet, there are sundries on the ground, the terrain is undulating (steps higher than 16cm, etc.), and the slope is large (more than 40°) and there are sharp objects on the ground or in the periphery.

10) Hand may be pinched at the motion joints, such as at the knee joint, please be careful.

Daily Care and Maintenance

Cleaning: After using Go2, if there are stains on the surface, please clean the surface of the body in time. Before wiping the body, please switch off the power, use a dry and clean soft cloth to wipe the body, pay special attention to the camera and radar whether to wipe clean.

Storage: Go2 is not dustproof or waterproof, it should be stored in a dry and cool room, avoiding sunlight and rain, so as not to shorten the service life of the parts due to water ingress and rust corrosion.

Routine inspections before and after use can significantly improve product reliability, reduce potential hazards and extend service life.

Uncharged Checklist

Type	Main Points
Appearance	<ol style="list-style-type: none">1. Whether the appearance of the body is clean, no signs of damage or deformation.2. Whether the lens on the camera surface has foreign matters.3. Whether there is no dust around the head LIDAR.
Structure	<ol style="list-style-type: none">1. Visually and touch to check whether the body, joints, connections, and foot end parts are in good condition.2. Ensure that the screws of all connecting parts are locked, especially the screws of joint connectors and battery locking knobs.3. Whether the inlet and outlet of heat sink are blocked by foreign matters.
Foot end parts	Check whether there is obvious foot pad damage.
Battery packs	<ol style="list-style-type: none">1. Check the battery pack interface of the body for foreign matters and deformation.2. Whether the battery pack is installed reliably to ensure that it will not loosen during operation.3. The battery pack with obvious damage is forbidden to be used.
Companion Remote control	Check whether each key of the remote control is lagged.

Charged checklist

Type	Main points
Remote control	<ol style="list-style-type: none">1. Confirm whether the basic operation function of the rocker is normal.2. Confirm whether the current power is sufficient.
Battery	Confirm whether the current power is sufficient.

Battery pack maintenance

- 1) Never charge the battery pack in an environment where the temperature is too high or too low
- 2) Never store the battery pack at room temperatures above 40°C.
- 3) Do not overcharge the battery pack as this will cause damage to the cells.
- 4) If you do not use the battery for a longer period of time, please check the remaining battery power regularly, if the power is less than 30%, please charge the battery to 70% before continuing to store. So as not to over-discharge the battery and damage the battery.

Disclaimer

To avoid violations against laws, possible injuries and damages, it is important to comply with all of the following:

1) This product is not a toy and is not intended for use by persons under the age of 14. Keep out of reach of children and be careful when operating in the presence of children.

2) Please be sure to read this article carefully before using the product, understand how to use the product correctly and your legitimate rights, responsibilities, and safety instructions. Once used this product, you are deemed to have carefully read, understood, recognized, and accepted all the terms and contents of this article. Users undertake to be responsible for their actions and all consequences therefrom. Users undertake to use this product only for legitimate purposes and agree with these terms and any relevant policies or guidelines that Unitree may establish.

3) To the fullest extent permitted by law, under no circumstances does Unitree provide any express or implied warranty with respect to this product, including, but not limited to, the implied warranties of merchantability, fitness for a particular purpose, or non-infringement. To the fullest extent permitted by law, Unitree disclaims all liability for damages arising from the user's failure to use the product in accordance with this document. Unitree will not be liable for any indirect, consequential, punitive, incidental, special or exemplary damages, including those suffered as a result of your purchase of, use of, or inability to use the Product (even if Unitree has been advised of the possibility of such damages). To the fullest extent permitted by law, in no event will Unitree's total liability to you (whether in contract or otherwise) for all damages, losses and actions arising out of or in connection with the use of the Product exceed the amount paid by you to Unitree for the Product (if any).

4) Unitree Robotics does not guarantee that the products / services provided are completely free from defects and fully meet the customer's requirements.

5) This product is strictly prohibited from private disassembly, modification, prohibit informal maintenance, the above behaviour caused by all failures and damage, Unitree does not assume any responsibility.

6) This product is strictly prohibited in unconventional environments (such as high temperature, extreme cold, chemical corrosion, fire blisters) and other scenarios of operation and use, Unitree will not assume any responsibility for all failures and damages caused by the above.

7) Under normal use of this product, the normal natural wear and tear of the parts and components and battery aging caused by the failure and risk of the burden as the normal use of the product risk, Unitree will not bear the corresponding consequences and responsibilities.

8) The laws of some countries may prohibit the exclusion of warranty terms, so your rights in different countries may be different.

9) Unitree reserves the right to interpret the above terms and conditions in accordance with the laws and regulations. Unitree reserves the right to update, revise or terminate these Terms at any time without prior notice.



目录

目录.....	1
安全须知.....	2
产品概览.....	3
功能示意图.....	4
如何充电.....	7
如何使用您的机器人.....	8
了解运输箱.....	8
准备机器人.....	9
启动 Go2.....	9
关闭 Go2.....	10
激活您的 Go2.....	11
操控您的 Go2.....	12
异常情况说明.....	15
注意事项.....	16
日常保养与维护.....	17
免责声明.....	18

安全须知

Go2 是一款全球高效卓越性能消费级交互四足机器人，您需要通过练习掌握操控技能。

- 本产品并非玩具，不适合未满 14 岁的人士使用。请勿让儿童接触，在有儿童出现的场景操作时务必特别小心注意。
- 您有义务知悉您所在区域的法律，并遵守相关法律法规。
- 本手册是玩家操纵机器人的入门章节，可以通过本手册快速掌握操控机器人的方法，抓住操作机器人的要领，举一反三，并且熟知哪些动作是不推荐使用，使机器人表现出卓越的运动性能。
- 机器人上电后，切勿将机器人提起，以免机器人进行不可预期动作，造成机器损坏！
- Go2 是纯电驱动四足机器人，具有一定的抗干扰性，但电机能量密度远低于液压，无法大力地突然地推机器人，更不能踹机器人，故因大力地突然地推或踹导致机器人摔倒损坏的，将不在保修范围内。

使用环境要求：

- 请不要在电磁干扰环境下运行机器人。电磁干扰源包括但不限于：高压电线、高压输电站、移动电话基站和电视广播信号塔。
- 请不要在 Wi-Fi 信号干扰环境下运行机器人。Wi-Fi 信号干扰通常由于同频干扰引起。受到干扰时，务必关闭部分或全部其他无线设备 Wi-Fi 信号源，然后再使用遥控设备操作机器人。
- 使用时，请保持机器人在视线范围内控制，使机器人时刻与障碍物、复杂地面、人群、水面等物体保持至少 2 米以上的安全距离。
- 在 5°C - 35°C，天气良好的环境下运行。恶劣天气请勿运行，如有雾、下雪、下雨、雷电、沙暴、暴风、龙卷风天气等。
- 机器人不防水，请勿在地面有水、雨雪天或潮湿环境等情况下运行！机器人不防尘，请勿在沙砾地面，粉尘环境下运行！
- 足式机器人对行走的地面有一定的要求。请勿在摩擦力非常小的地面使用机器人，如冰面。请勿在松软的地面使用机器人，如较厚的海绵地面。如在较光滑的地面使用，如玻璃、瓷砖等地面，请小心并柔顺的操控机器人进行运动，避免剧烈运动，并降低机器人的行走速度，防止机器人足端打滑而摔倒。

使用前准备：

- 仅使用 Unitree 正品部件并保证所有部件工作状态良好。
- 确保固件等已经更新至最新版本。
- 用户确保自己不在醉酒、药物影响或无法集中注意力情况下操控机器人。
- 熟悉了解每种步态模式的特点。熟悉机器人失稳/失控情况下紧急制动方法。
- 确保机器人及各部件内部没有任何异物（如：水、油、沙、土等）。
- 确保机器人摄像头和激光雷达表面无灰尘，四周没有遮挡物。

产品概览

整机

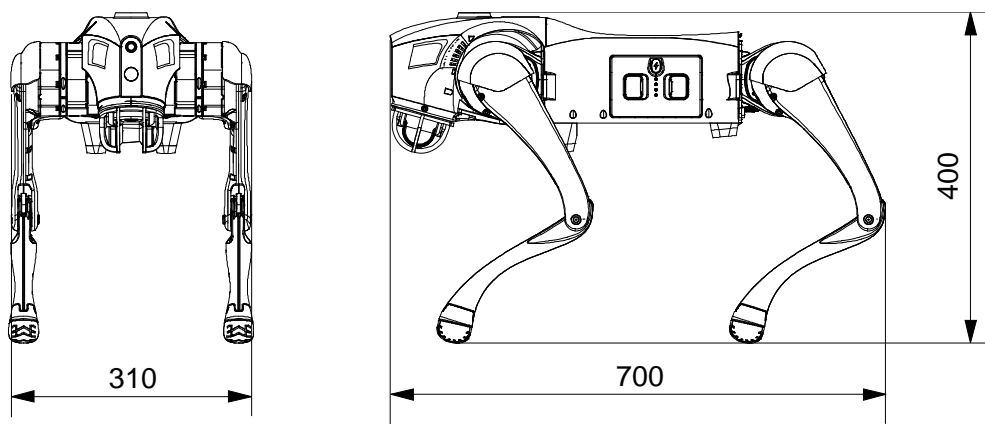

通用附件

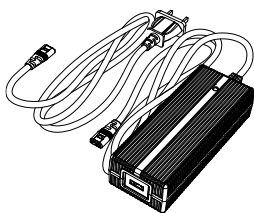

充电器 x 1

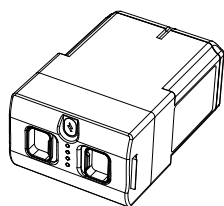

电池 (8000mAh) x 1

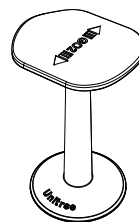

展示支撑架 x 1

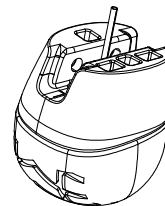

赠送足端 x 4

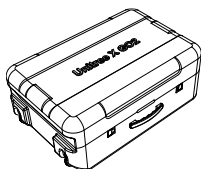

专用行李箱 x 1



使用手册 x 1

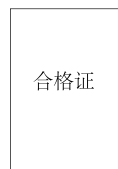

合格证 x 1



反修卡 x 1

PRO 额外附件



伴随遥控器 x 1



Type-C 线 (1米) x 1



请仔细检查行李箱内物品是否齐全完好, 本说明书所有图片仅供参考, 若实际物品与说明书不符, 请以实物为准。不同型号的配件会有所不同, 具体请以实际型号为准。要获得具体型号规格参数信息, 请访问宇树 Unitree 官网: www.Unitree.com。

功能示意图

Unitree 全新升级交互仿生四足机器人 Go2, 整机有 12 个自由度 (12 个铝合金精密关节电机组成), 使用力控技术对每个关节进行力和位置的复合控制, 以实现对整机的力控而获得卓越的运动性能。整机采用铝合金和高强度工程塑料, 大大提高机器狗可靠性; 最大奔跑速度可达 5m/s (实验室环境下所测得速度); 搭载 4D 激光雷达 L1, 360°×90°半球形超广角感知能力, 可帮助 Go2 实现无盲区覆盖。无论是在结构、运动性能和环境感知伴随等各个方面都达到国内外领先水平。

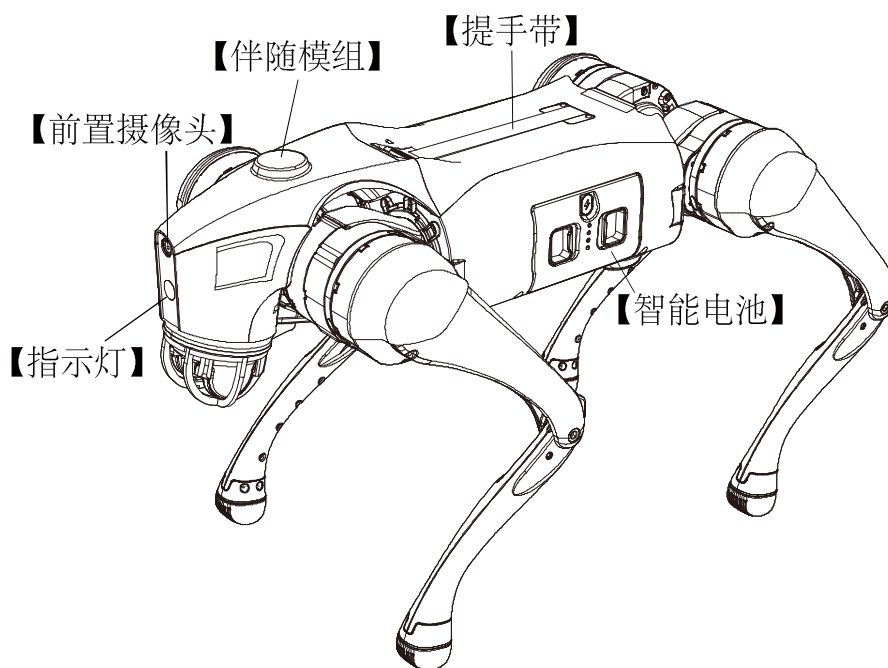
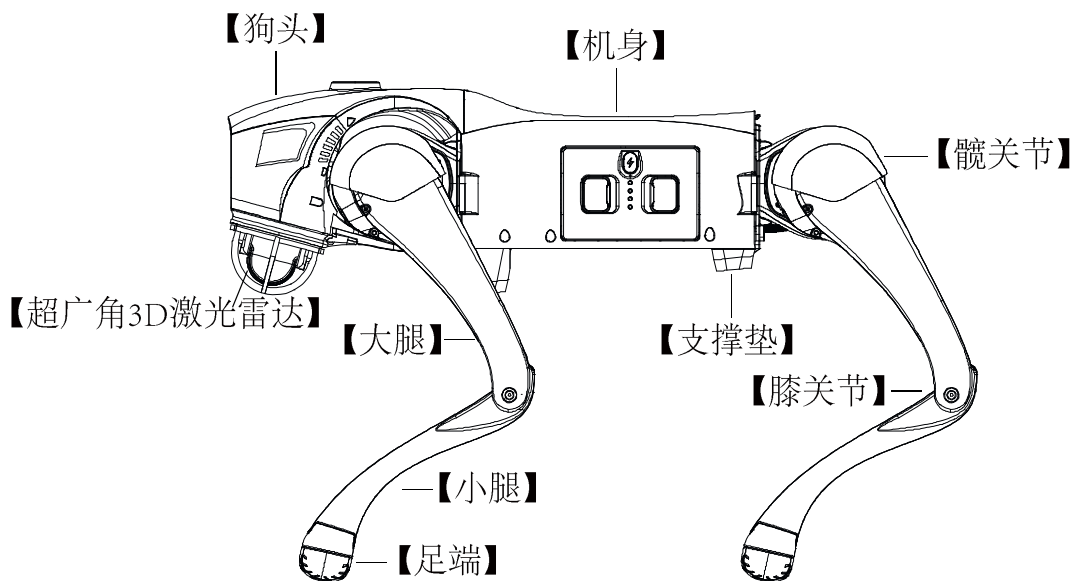

Go2 功能区别

功能	AIR	PRO
基础运动、跳舞等	●	●
状态指示	●	●
智能 OTA 升级	●	●
UNITREE GO 软件	●	●
WI-FI 6 / 蓝牙	●	●
探物避障	●	●
4G 图传	○	●
智能伴随	○	●
语音交互	○	●
自动伸缩提手带	○	●

● 状态指示

Go2 头部前置指示灯可发出不同光亮，指示机器人当前工作状态、当前运行系统的状态，请参考下表了解不同闪灯方式及颜色所表示的运行状态：

颜色状态	含义
绿灯呼吸	开机中
绿灯常亮	开机完成，默认避障开启
蓝灯常亮	避障关闭
黄灯常亮	续航模式
紫灯常亮	伴随模式开启状态
蓝灯慢闪	电机&IMU 标定中
黄灯慢闪	低电量预警，10 分钟内将自动爬下
红灯慢闪	系统异常，开机失败，硬件故障、需要联系售后
红灯快闪	电机&IMU 标定失败
白色常亮	前置探照灯 (3w)



灯光优先级：伴随模式开启（紫灯常亮）>续航模式（黄灯常亮）>避障关闭（蓝灯常亮）

● 探物避障

搭载 Unitree 自研 4D 激光雷达 L1，360°×90°半球形超广角感知能力，拥有超低盲区，最小探测距离低至 0.05m，可以帮助 Go2 实现无盲区覆盖，可实时获取周围环境的三维信息，并且在行进过程中根据雷达数据进行智能避障（仅支持向前避障），避免与障碍物发生碰撞，保障机器人和周围环境的安全。

● ISS2.0 智能伴随系统 (AIR 不支持)

Go2 采用全新的无限矢量定位及控制技术，定位精准技术提升 50%，遥控距离大于 30 米，并结合优化的避障策略，可以使机器人更好的适应复杂环境，人机交互更加自然融洽、安心、安全。

● 语音交互 (AIR 不支持)

支持语音交互及指令，内置语音识别模块，将人类语言转换成计算机语言与主芯片进行通讯，从而控制机器人，实现人机语言交互。毫秒级语音交互响应，采用行业先进的语音识别技术，识别准确率高，识字速度快。

● App 远程图传

配套全新 Unitree Go App，提供全向广角视频图传，实时查看拍摄画面，内置 4G 及 eSIM (AIR 不支持)，更稳定连接、远距离控制。支持智能 OTA 升级，使得超视距范围内的操作变得和身在现场一样简单方便。

● 自动伸缩提手带 (仅 PRO 版本)

Go2-PRO 版本全新升级自动伸缩提手带，内置双向拉伸卷线器，通可以根据用户的需要调节提手的高度。自动伸缩提手带以电机驱动的形式带动提手带伸长 / 收缩，使 Go2 在外观上更加简洁美观。

自动伸缩手提带使用方法：Go2 上电后，向后推提手带伸缩按钮，可以将提手带拉出到合适位置固定，向前推提手带伸缩按钮，提手带会自动收回。

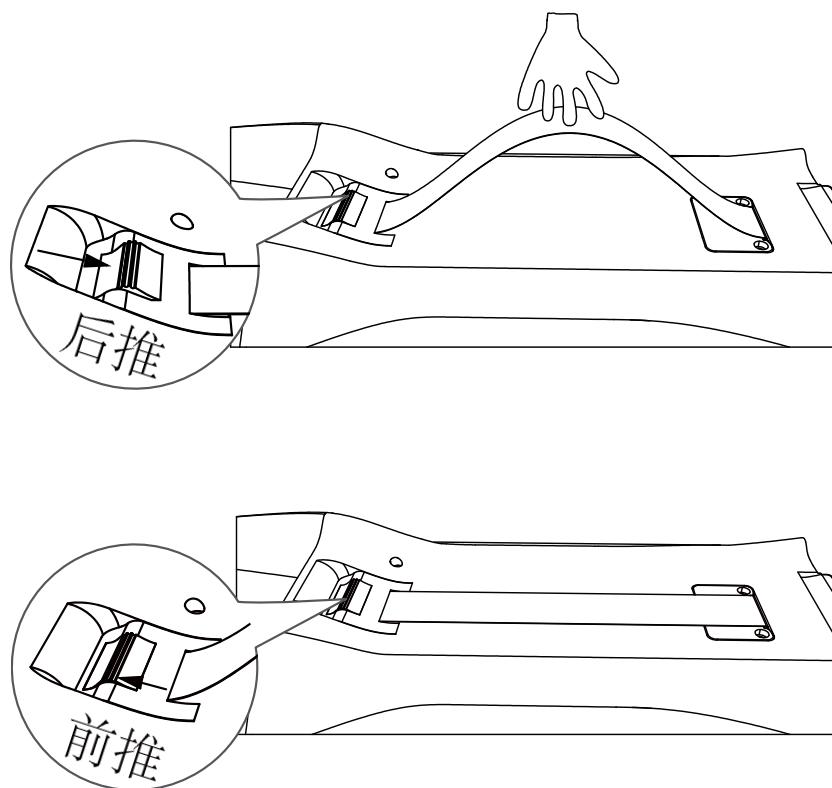

如何充电

由于运输和储存过程中电池自耗等原因，首次使用时电量偏低或电量为空属于正常现象，按照以下方式充电即可。

● Go2 电池充电

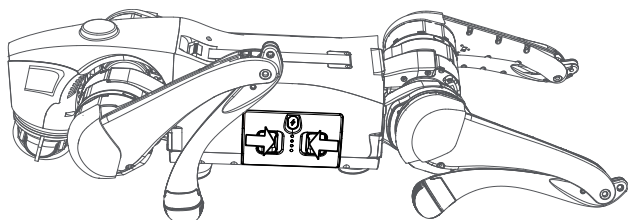

①将 Go2 电池从机身中取出
(双手按住电池包两个卡扣)

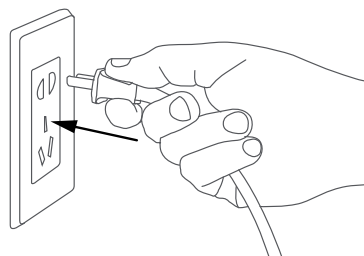

②充电器先插入输入交流电源
(100-240V, 50/60Hz)

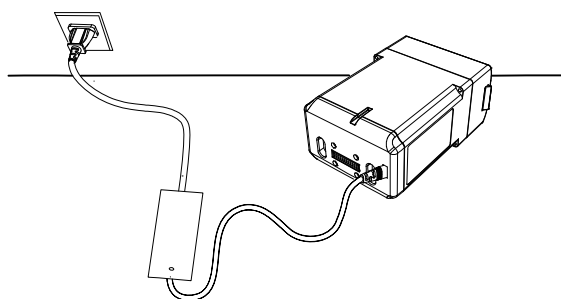

③连接 Go2 电池

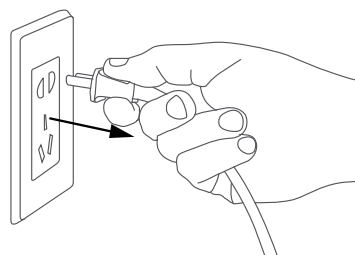

④充满电后手动断电

● 伴随遥控器充电

当伴随遥控器电量指示灯显示低电量时，应将伴随遥控器连接充电器，如下图所示：

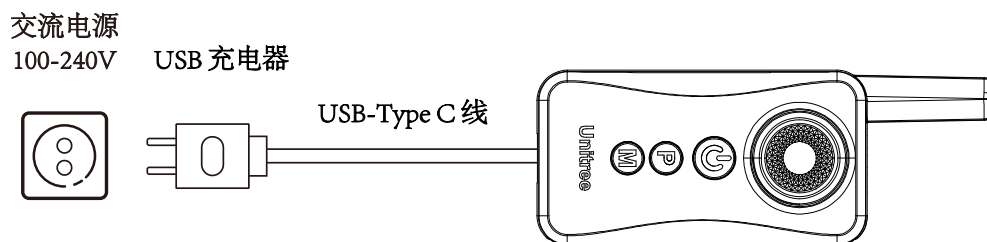

1. 推荐使用符合 FCC/CE 标准，5V/1A 的 USB 充电器。
2. 充电状态下电源指示灯会按 1Hz (1 秒 / 次) 频率闪烁，并指示当前电量。
3. 电量指示灯全部熄灭时表示电池包已经充满，请取下充电器，完成充电。

如何使用您的机器人

了解运输箱

图仅用于说明部件摆放位置，实际物品请以收到内容为准。以下所有图片主要以 Go2-PRO 为例，不同型号的配件会有所不同，具体请以实际型号为准。

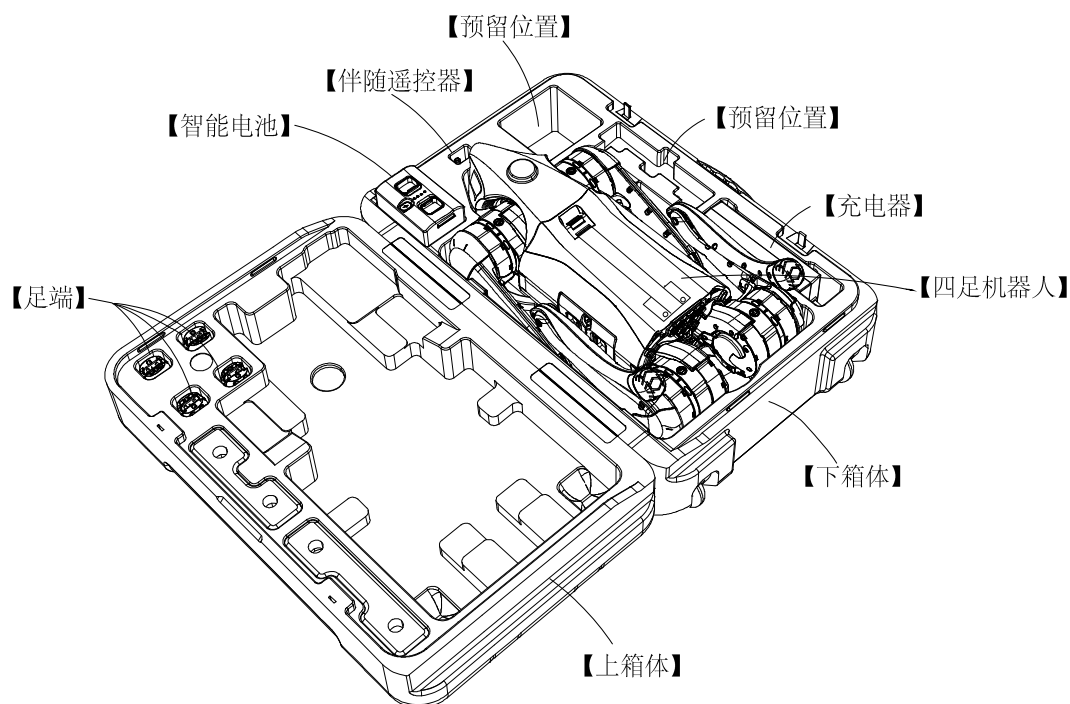

开箱

在平整的地面上正面朝上摆放箱体，然后打开上箱体。用提手带把机器人整体抬起，将配件依次从箱内取出。学习如何正确使用机器人后，将四足机器人平放在平整的地面上，然后进行开机准备。

装箱

装箱前准备：将四足机器人的腿转动到如图示的位置（后腿收起步骤：旋转后腿髋关节电机使后大腿摆放至上图示位置，同时收起后小腿摆放至图示位置。

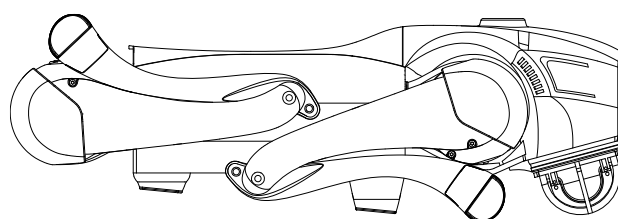

完成装箱前的准备工作后，将四足机器人按图示方向装入下箱体内（装入过程中注意将四足机器人头部卡入头部放置部中）。四足机器人装入下箱体后，将随货附带的电池、充电器等分别放入运输箱内的相应位置，确保在上箱体合上时，以上部件都不会掉落。

准备机器人

(1) 安装电池包

将 Go2 放在平坦的地面上，将电池包从机器人侧面插入电池槽，注意安装方向，电源开关键朝上，不要强行按压，以免损坏电池接口和卡扣，当听到“咔哒~”声，电池包安装完成。

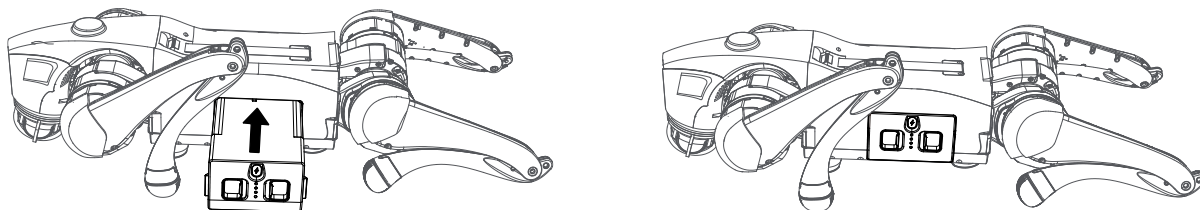

(2) 机身摆放 (重要步骤!!!)

卧式开机：请确保开机运行前机器人放置在平整地面上，机器人腹部支撑垫需平贴地面，机身水平无倾斜趴在地面，机器人小腿呈完全收起状态（如下图），四个膝关节以及足端平放在地面上，确保机器人大腿和小腿都没被机身压住。

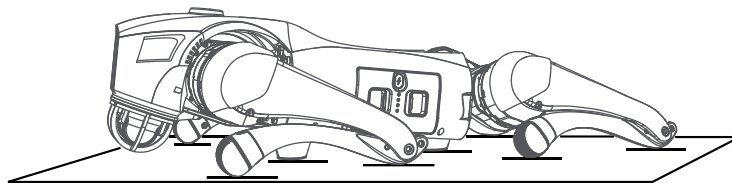

启动Go2

机器人完成机身摆放要求后，按照如下步骤开机：先短按 Go2 电源开关键 1 次，再长按电源开关键 2 秒以上，可启动 Go2。Go2 启动过程时，头部指示灯绿色呼吸，等待 2 分钟后，头部指示灯为绿色常亮，Go2 机身与地面平行即开机成功。

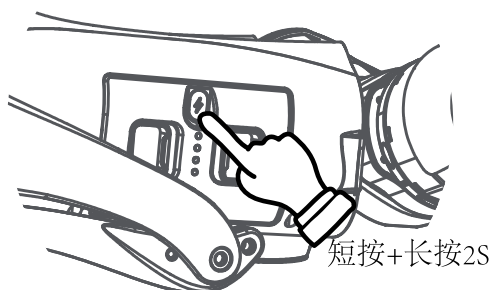

- 若开机失败，请仔细检查机身摆放。
- 大小腿靠外伸或小腿靠内被压住都可能导致 Go2 开机失败。
- 运动关节处小心夹手，请小心谨慎！

关闭Go2

关机前，请务必确保机器人站立在平整地面上，确保机器人处于静态站立状态（机器人机身位置处于开机起立后的初始状态，机身水平，静态站立时的状态）。

- 操纵机器人进入卧倒状态；
- 机器人进入卧倒状态后，先短按电源键再长按电源键 2 秒关机。

关机后，请按照机身摆放要求，摆放好 Go2 大小腿和髋关节位置，为下次开机做准备。若长时间不使用 Go2，请取下电池包，按照装箱步骤，将 Go2 装入专用行李箱。



- 请确保机器人处于趴下状态（卧倒状态或阻尼状态）下进行关机，否则机器人关机掉电后会重重地摔在地上，可能会造成机身损坏，并存在一定的安全隐患！若开机失败，请检查机器人机身摆放是否正确。

激活您的Go2



首次使用需要先激活，请扫码左侧二维码安装 Unitree Go App，按照 App 提示激活 Go2 并完成内置教学。激活过程中，请打开手机蓝牙，将手机靠近 Go2，保证蓝牙实时通讯。绑定成功后，您可以开始操控机器人。

①安装 App 后请先注册 / 登录。

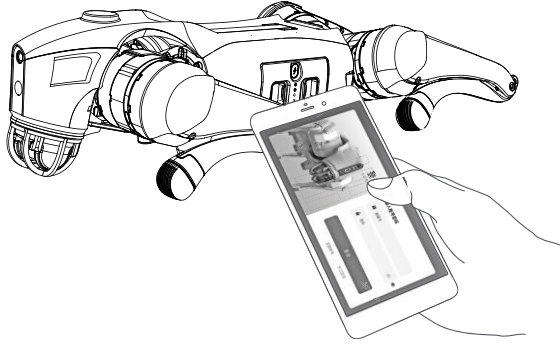

②启动 Go2：头部指示灯绿色常量，机身与地面平行

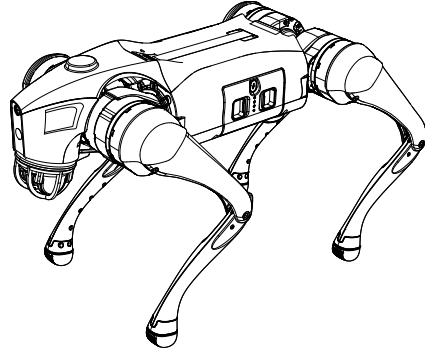

③添加机器人：首页点击-添加机器人-打开手机蓝牙连接您的 Go2-设置机器人信息。

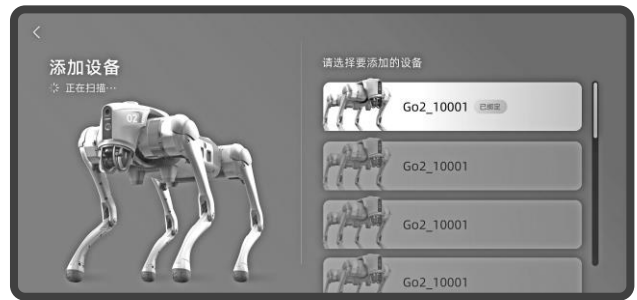
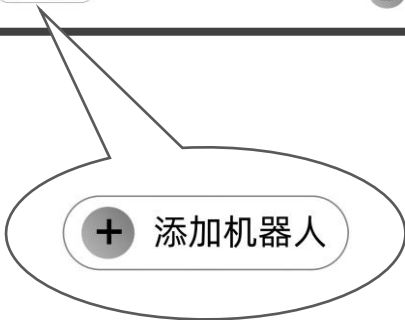
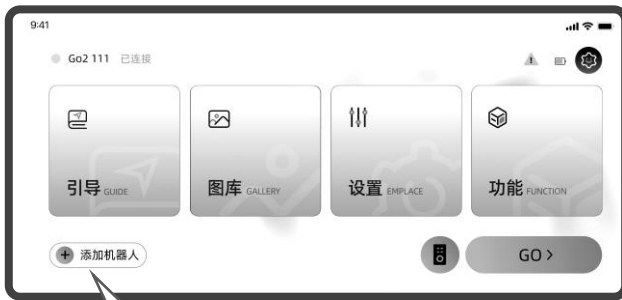

④绑定机器人：您可以选择 AP 路由器模式和 Wi-Fi 连接模式连接，连接成功后您可以学习内置教程来快速掌握操作技巧。



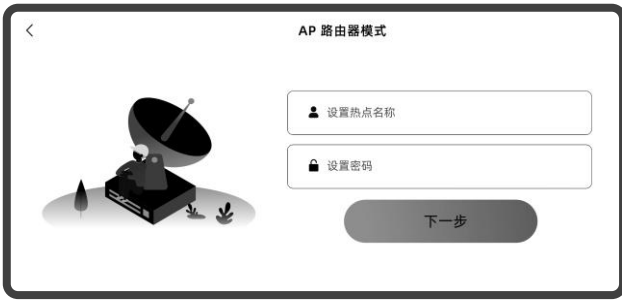

• 如何更换账户绑定?

首页点击设置 - 机器人设置 - 切换连接, 选择点击解除绑定, 可以对已绑定的机器狗进行解绑。机器狗解除绑定后, 可以被其他用户绑定。



- 连接过程中请保持手机蓝牙开启!
- 蓝牙连接报错: Unitree Go App 需要获取蓝牙权限, 请在手机 App 中打开 Unitree Go 蓝牙权限。
- 若忘记绑定账户、账户丢失, 请与 Unitree 相关人员联系!

操控您的Go2

● 使用 Unitree Go App 控制

完成 Unitree Go App 引导当中的内置教程后，可以使用 App 随意操控您的机器狗。

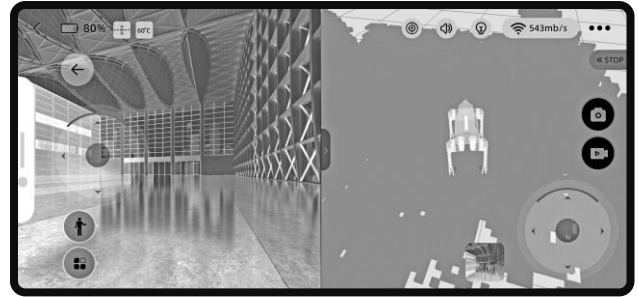

● 使用语音控制 Go2 (AIR 不支持)

Go2-PRO 内置语音模块，您可以使用以下语音指令来控制 Go2 完成对应动作。

类型	词条	语音回答	对应动作
唤醒	你好笨笨	我在	
开机	增大音量/声音大点	好的主人	调节音量
命令词	减小音量/声音小点	好的主人	调节音量
命令词	跳舞/跳个舞	轮到我开始表演了	做跳舞动作
命令词	扭屁股/扭扭屁股	早睡早起咱们来做运动	执行扭屁股
命令词	作揖/拜年/拜个年	恭喜发财红包拿来	起立作揖
命令词	锁定/锁定模式/停下/别动了	立正	停止运动并锁定
命令词	解除锁定/解锁	已进入运动模式	解除锁定
命令词	向前走/走两步	我来啦	解除锁定并启动运动模式前进 2s
命令词	爬楼梯/爬楼梯模式	我要一步一步往上爬	启动爬楼梯模式
命令词	跑起来/跑步模式	我是牛翔	启动跑步模式
命令词	避障/开启避障/打开避障	已经打开避障模式	启动避障模式
命令词	关闭避障/退出避障	已经关闭啦	关闭避障模式
命令词	打个滚/打滚	给大家表演一个侧滚翻	停止运动并打滚
命令词	伸个懒腰/伸懒腰	睡得真舒服	伸懒腰动作
命令词	握手/握个手	拉个手我们就是好朋友	停止运动并抬起前腿握手 (2s)
命令词	趴下/卧倒/蹲下	我好困休息一会	停止运动，先切站低状态，再进入阻尼模式
命令词	站起来/起立	汪汪队准备出发	恢复站立并锁定



请访问 Unitree Go App—Go2 语音词条，获取更多内容！

● 使用伴随遥控器控制 Go2 (AIR 不支持)

在通电之前，伴随遥控器应固定在如图位置，机器人开机成功后，可以使用伴随遥控器控制 Go2，具体操作步骤如下：

Step 1: 佩戴并启动伴随遥控器

1. 将伴随遥控器外扣于人体右侧腰带上，人体站在机器人正左侧，躯干朝向保持与机器人一致。
2. 短按伴随遥控器的电源键，当指示灯稳定亮起时打开完毕，此时遥控器为摇杆模式。



Step 2: 启动跟随模式 (重要步骤)

1. 快速短按两次 M 键，开启慢速自动伴随模式，最大速度 1.5m/s。
2. 在慢速自动伴随模式下，再次快速短按两次 M 键，进入快速自动伴随模式，最大速度 3.0m/s。

Step 3: 开启 / 关闭避障功能

连续短按两次 L2 键开启避障；短按 1 次关闭避障。

Step 4: 关闭自动跟随功能。

1. 短按一次 M 键：关闭伴随，进入摇杆控制模式。
2. 拨动摇杆：拨动摇杆，立刻停止伴随模式，并进入摇杆模式。
3. 关机：长按 2 秒自动伴随遥控器的电源键，关闭自动伴随遥控器。
4. 水平放置：伴随遥控器水平放置。

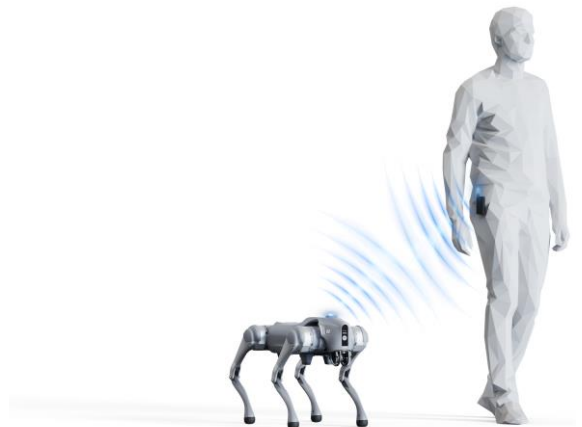

其他操作说明 (用于调整机器)

1. 摇杆控制：伴随遥控器进入摇杆模式后，可通过摇杆控制机器人运动。使用摇杆控制模式，可以把遥控器从腰带上拿下进行控制。如果遥控器拿下后需要继续使用自动跟随，则需要把遥控器佩戴后，再开启伴随。
2. 站起、趴下、阻尼模式：连续短按 P 键 2 次，机器人在趴下、阻尼和站起三种模式间循环切换。
3. 侧滚翻：机器人侧翻时，长按 P 键 1 秒，可恢复站立。



自动跟随注意事项：

- 速度不能过快（慢速模式小于 1.5m/s，快速模式小于 3.0m/s）。
- 携带伴随遥控器不能放置的过高（与机器人头部高度差约-10cm~120cm 内）。
- 在条件允许的情况下，选择更开阔的路线，尽可能减少机器人本身的自主规避功能的触发。
- App 端无法与伴随遥控器同时控制机器人，如需使用伴随遥控器控制，请勿使用 App 控制机器人。
- 使用时，请保持机器人在视线范围内控制，与使机器人保持至少 2 米以上的安全距离。

异常情况说明

在使用 Go2 四足机器人时，可能会出现机器人异常的情况。大部分异常情况是可控的（有解决方案），客户在遇到这些问题时不要慌张，仔细阅读下列内容并按步骤解决问题。

如有疑问，可联系宇树 Unitree 官方技术支持：support@Unitree.cc

● 开机后未起立，头部闪烁红灯

Go2 头部红灯慢闪，这就意味着开机失败，仔细检查机器人开机摆放位置，重新摆放后再重新开机。若仍开机失败，系统异常或硬件故障，此时需要联系 Unitree 官方技术支持排除具体故障原因。

● App 连接异常

若采用 AP 连接模式，可检查手机是否连上 Go2 发出的 Ap 热点。

若采用 Wi-Fi 连接模式，可检查所连接 Wi-Fi 网络是否正常，能连上外网。

若采用 4G 连接模式，可在 App 的【设置】->【移动网络】下，查看当前流量情况，确保 4G 物联网卡能正常联通外网。

● 无法使用 App 操控 Go2?

Go2 伴随遥控器与 App 无法同时控制 Go2，若要使用 App 操控 Go2，请先退出伴随模式。长按 2 秒自动伴随遥控器的电源键，关闭自动伴随遥控器。随后可使用 App 操控 Go2。

● 开机站立姿态异常

Go2 开机后行走姿势异常，出现易摔倒等情况，重启机器人无法解决问题，此时需要按照 Unitree Go App 相关步骤对机器人关节重新进行标定。

注意：Go2 出厂后默认已经完成标定，正常使用请勿进行关节标定！在 Go2 出现异常情况后请先咨询 Unitree 官方技术支持后确定是否需要重新标定关节！

App 关节标定入口为【设置】->【数据】->【机器狗】->【iMu 信息】->【标定】。

● 雷达受到外力后停止转动

通常情况下，当外力释放后，雷达会自动重新恢复转动。此时若无法恢复，可尝试用手拨弄给予雷达一定的速度，若依然无法解决，请尝试重启 Go2。重启后无法解决，可通过查看 App 上的故障详情，再咨询 Unitree 官方技术支持。

● 还原出厂设置

Go2 背部设置复位按键，可以完成 Go2 出厂化设置。操作方法如下：关机状态下按下复位按键（长按，不松开），给 Go2 电池上电（短按 + 长按 2 秒），即可还原出厂设置。Go2 上电后等待黄灯呼吸闪烁，此时可以松开复位按键，等待 Go2 头部绿灯亮起，系统重置成功，大约需要 30 分钟。

注意事项

- 请确保机器人处于卧倒状态下进行关机，否则机器人关机掉电后会重重地摔在地上，可能会造成机身损坏，并存在一定的安全隐患！
- 站立时，当地面摩擦力不足或者机器人的足没有可靠支撑时，请勿剧烈操控机器人进行姿态调整（包括俯仰、横滚、偏航、机身高度调整等），否则可能引起机器人失稳摔倒。
- 请在平整地形稳定操控下行走。如在摩擦力较小的地面行走时，请勿剧烈操控机器人，否则可能引起足端打滑失稳摔倒。
- 机器人空载静态站立与直立行走交替运行的额定续航时间约为 1-2 小时左右。具体根据机器人实际运行的工况而定，比如长时间较快速度的行走、机器人站立时较长时间剧烈调整机身姿态、机器人腿弯曲站立、带负载运行、较低机身高度行走、有适当起伏和坡度的地形等工况，都会降低续航时间。（机身高度较低，膝关节弯曲比较大时，电机的负担较大，故会显著早增加功耗，并伴随着电机发热）
- 由于实际操控人员的操控熟练水平不一，故为了可靠稳妥起见，目前不推荐客户走超过 16cm 的台阶，不然很可能会因操作不当而绊到脚。在遇到有起伏的地面时，操控人员也应当小心谨慎，并降低机器人的运动速度。
(AIR 版本最大攀爬落差高度 15cm)
- 额定正向爬坡角度小于等于 40° ，当采用较大爬坡角度时（约等于或大于 40° 时），机器人机身很可能会侧向漂移，在较大坡度的斜坡上直接转弯，很可能使机器人失稳；爬坡时，请降低行走速度；需要操控人员妥善控制。（AIR 版本最大攀爬角度 30° ）
- 在平整地形稳定操控下最高速度可达 3.5m/s。（AIR 版本最高速度 2.5m/s）
- 机器人足端组件是消耗品，我们会随货赠送备用足端组件。尤其在在比较粗糙的地面运行时磨损会比较严重，如发现比较明显的足垫磨损、破损，或者发现机器人行走时对地面的冲击噪声明显加大，请及时更换足端组件，以免足端组件损坏导致机器人运动失常或摔损。
- 禁止在地面复杂，地面湿滑，地面有杂物，地形起伏较大（台阶高于 16cm 等），坡度较大（大于 40° ）地面或周边有尖锐物体的场合使用机器人。
- 运动关节处小心夹手，如膝关节处。

日常保养与维护

● **清洁**：使用 Go2 后，若表面有污渍请及时清洁机身表面。擦拭机身前请先关闭电源，使用干燥且干净的软布对机身进行擦拭，尤其关注相机和雷达是否擦拭干净。

● **存放**：Go2 不防尘不防水，需存放于干燥、阴凉的室内，避免日晒及雨淋，以免零部件进水锈蚀而缩短使用寿命。长时间存放时取出电池包。

在使用前后开展例行检查，可大幅度提升产品可靠性能，降低安全隐患，延长使用寿命。

不带电检查表

类型	要点
整机外观	<ol style="list-style-type: none">1. 机身外观是否清洁、无破损或变形痕迹2. 相机表面镜片有无异物3. 头部激光雷达周围有无灰尘
结构	<ol style="list-style-type: none">1. 目视及触摸检查机身、各个关节及连接处、足端组件是否完好，有裂纹或者有破损需及时更换和联系 Unitree 售后2. 各个筒部件螺丝是否缩紧，尤其关注关节连接件和电池锁紧旋钮的螺丝3. 散热风扇进出口有无异物阻塞
足端组件	检查有无明显的足垫破损，若有破损请及时更换
电池包	<ol style="list-style-type: none">1. 机身的电池包接口有无异物，变形2. 电池包安装是否可靠，确保运行时不会松脱3. 电池包外壳是否有明显损伤，有明显损伤的电池包禁止用于使用
伴随遥控器	伴随遥控器的各个按键是否存在卡顿

上电检查

类型	要点
伴随遥控器	<ol style="list-style-type: none">1. 确认摇杆的基本操作功能是否正常2. 确认当前电量是否充足
电池	确认当前电量是否充足

电池包保养

- 切勿在温度过高或温度过低的环境下使用充电器对电池包进行充电。
- 切勿将电池包存储在室温超过 40°C 的环境下。
- 切勿过充电包，否则将对电芯造成损害。
- 若较长时间不使用电池时，请定期检查电池剩余的电量，如果电量低于 30%，请把电池充电到 70% 后再继续保存，以免电池过放而损坏电池。

免责声明

为避免违法行为、可能的伤害和损失，务必遵守以下各项规定：

- 本产品并非玩具，不适合未满 14 周岁的人士使用。请勿让儿童接触本产品，在有儿童出现的场景操作时请务必特别小心注意。
- 请务必在使用产品前仔细阅读本文档，了解如何正确使用本产品，了解您的合法权益、责任和安全说明；否则，可能带来财产损失、安全事故和人身安全隐患。一旦使用本产品，即视为您已理解、认可和接受本文档全部条款和内容。使用者承诺对自己的行为及因此而产生的所有后果负责。使用者承诺仅出于正当目的使用本产品，并同意本条款及 Unitree 可能制定的任何相关政策或者准则。
- 在法律允许的最大范围内，在任何情况下，Unitree 不对本产品提供任何明示或暗示的保证，包括但不限于可销性、特定用途的适合性或不侵权的暗示保证。在法律允许的最大程度下，Unitree 不承担因用户未按本文档使用产品所引发的一切损失。并不对任何间接性、后果性、惩罚性、偶然性、特殊性或刑罚性的损害，包括因您购买、使用或不能使用本产品而遭受的损失，承担责任（即使 Unitree 已被告知该等损失的可能性亦然）。在法律允许的最大程度下，在任何情况下，Unitree 因所有损害、损失及引致诉讼而对您所负的总法律责任（不论以合约或其他形式）均不会超出您购买产品（如有）而向 Unitree 支付的金额。
- 本产品严禁私自拆卸、改装，禁止非正规的维修，上述行为所引起的一切故障及损坏，Unitree 不承担任何责任。
- 本产品严禁在非常规环境（如高温、极寒、化学腐蚀，大火水泡）等场景下操作使用，上述因此所引发的一切故障及损坏，Unitree 均不承担任何责任。
- 本产品在正常使用情况下零部件正常的自然损耗及电池老化所引发的故障及风险负担视为产品正常使用风险，Unitree 方不承担相应的后果及责任。
- 某些国家的法律可能会禁止免除担保类条款，因此您在不同的国家的相关权利可能会有所不同。
- 在遵从法律法规的情况下，Unitree 享有对以上条款的最终解释权。Unitree 有权在不事先通知的情况下，对本条款进行更新，改版或终止。

Unitree 技术支持

Unitree Support

<https://www.unitree.com>

内容如有更新，恕不另行通知

您可以在 Unitree 官方网站获取更多文档

<https://www.unitree.com/download>

If you have any questions or suggestions about the manual, please contact us at the following

E-mail address: support@unitree.cc

© 2023 宇树科技 版权所有



微信扫一扫，关注 Unitree 公众号