

# XAG P100 Pro Agricultural Drone

Pro in Every Flight



# Recognition & Certification

**Crop Science Awards**  
Best Innovation in Precision Farming Technology

**Reuters Responsible Business Award**  
Sustainability Innovation Award

**Red-Dot Design Award**

**G-Mark Good Design Award**

**Fortune Best Designs China**



110,000

Agricultural Drones &  
Robots Delivered

57

Countries/Regions  
Use XAG

97M

Hectares of Farmland  
Treated

# Developed Exclusively for Agriculture



Limited to 30m AGL



Geo-Fencing Enforced

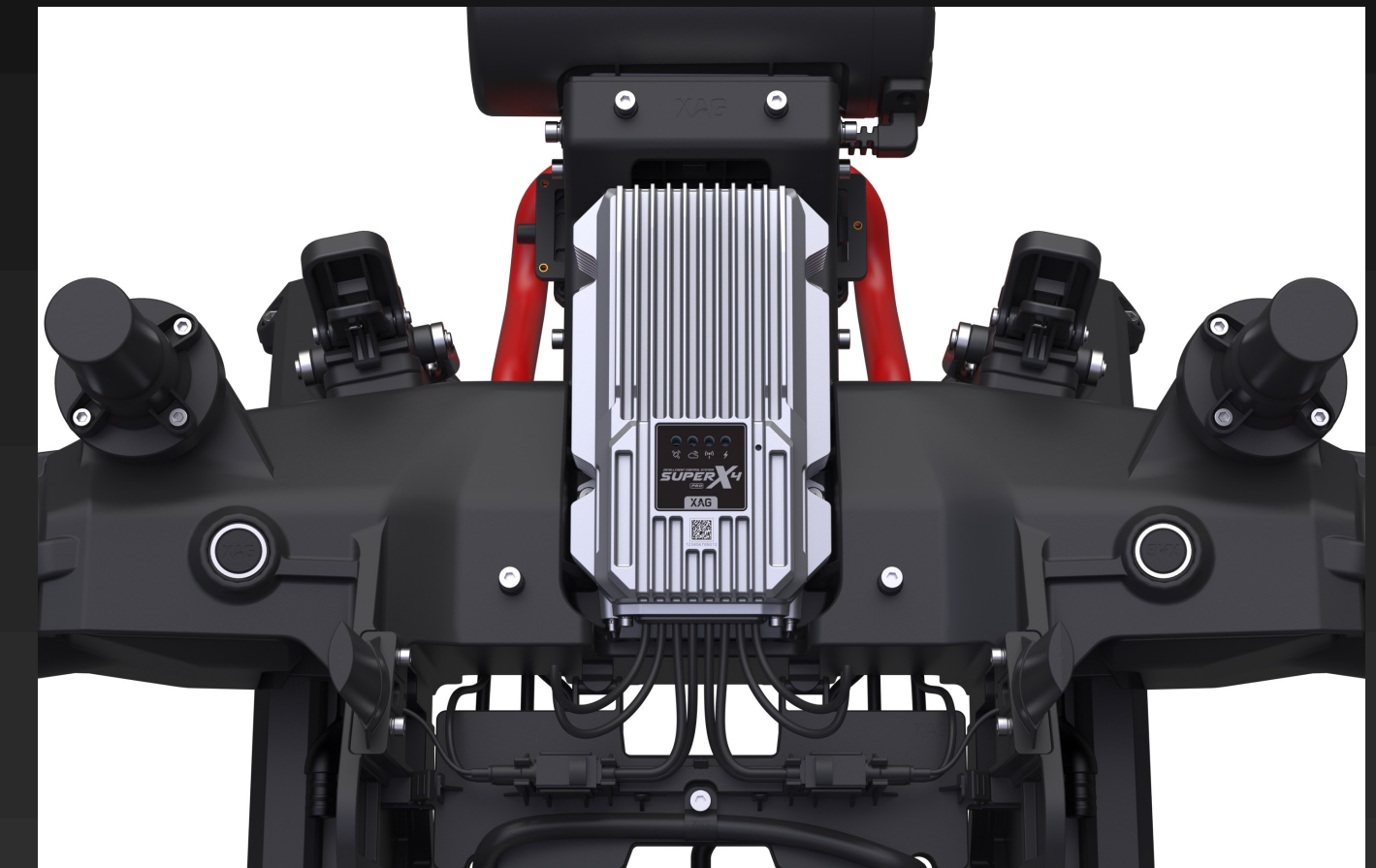

Fully Encrypted



# XAG P100 Pro Agricultural Drone



## Design

Foldable  
Multi-rotor



Integrated  
Platform

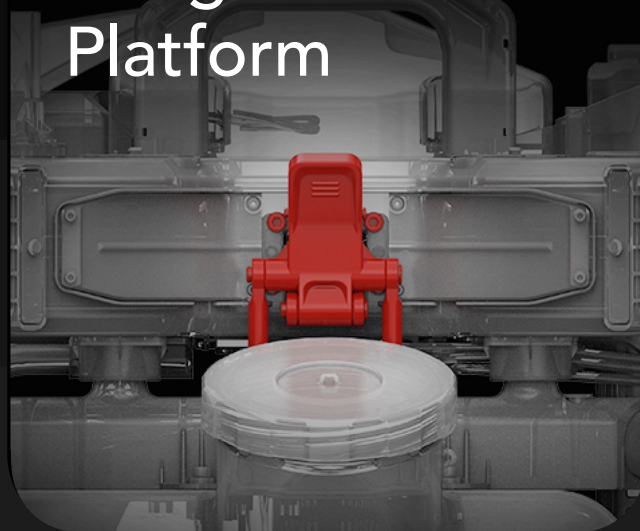

Plug and  
Play



IPX6K  
Protection



## Intelligence

SuperX4 Pro  
Intelligent  
Control System



4D Imaging  
Radar

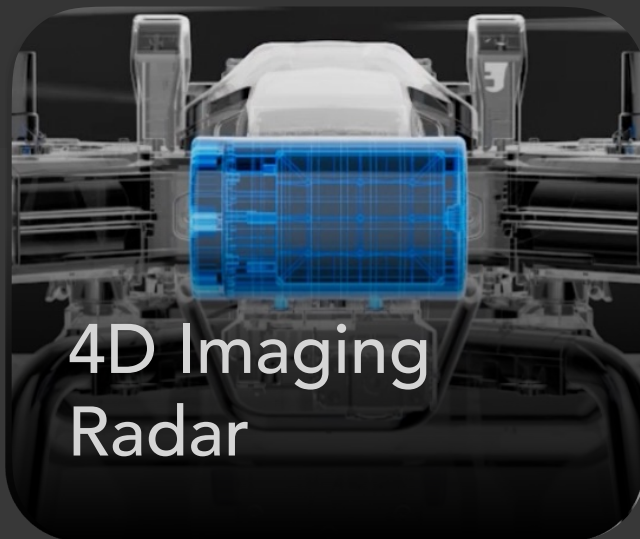

Pilot Sight  
Livestream PSL



ARC3 Pro  
Remote  
Controller



Electric  
Power

Water Cooling  
Battery



## Capability

Precision Spray  
Rotary Nozzles



22L/min      50L  
Max. spray width      Smart Tank

Aerial Spreading



150 kg/min      80L  
Max. spread rate      Container

 Design

# Airframe & Application System



## Design

- Folding design for easy transport
- One cable connection plug and play
- IPX6K protection for a longer service life





## Big Enough

Rated payload  
increased to **50 kg**



## Yet Small Enough

Folding design  
reduces volume by **62%**



INTELLIGENT CONTROL SYSTEM  
**SUPERX4** Intelligent Control System  
PRO

Designed for the AgriFuture

1 GHz Independent Processor

Dual-antenna RTK +  
Fixed/Portable Station Access

Dual-link Communication

AI Fault Prediction

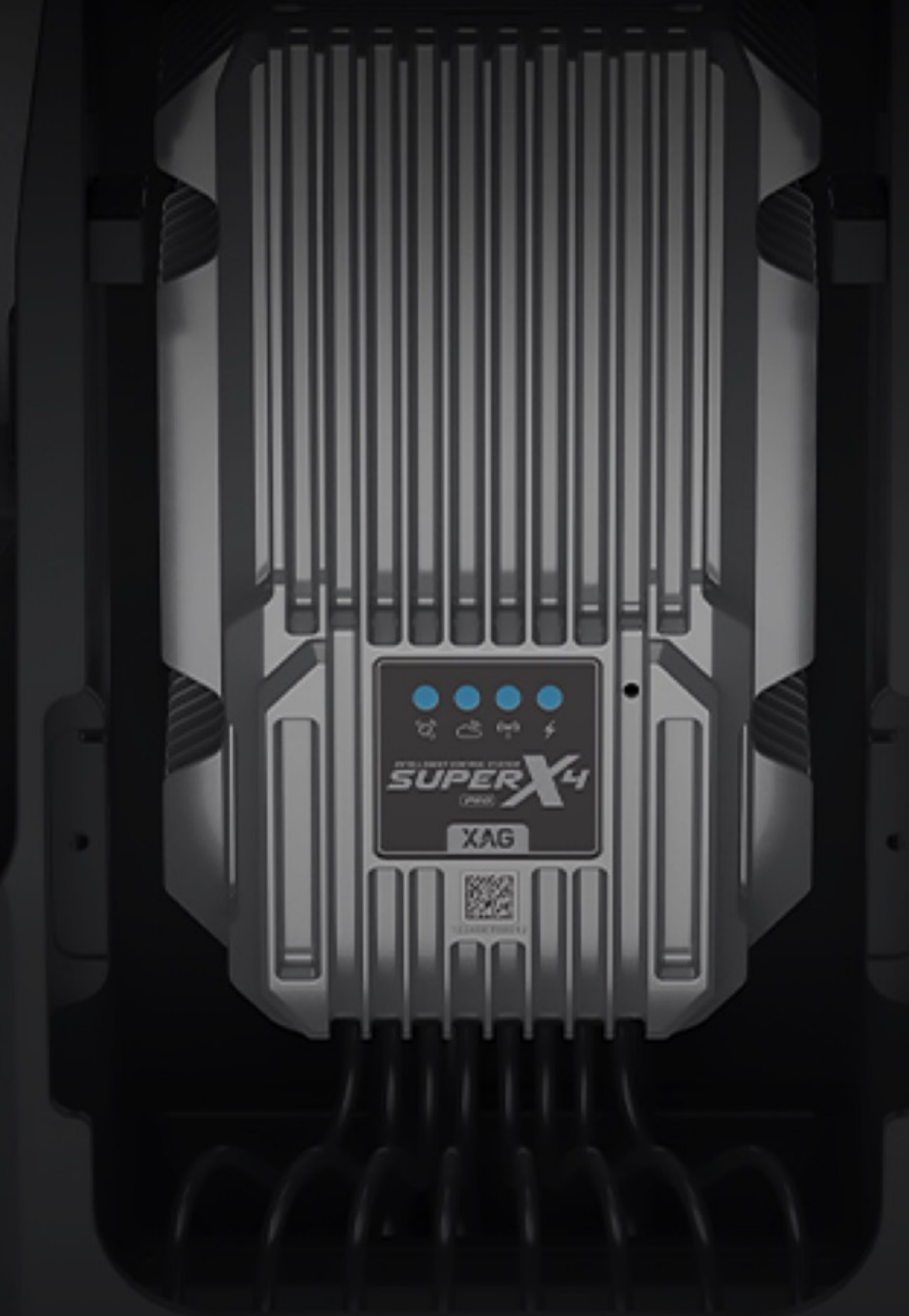

## 4D Imaging Radar

# Highly Efficient, With Safety First

Dynamic obstacle detection with an increased range  
Dual PSL cameras to keep track of field conditions

**1.5-80 m**

Detection range

**13.8 m/s**

Max. relative speed of  
obstacle avoidance



## XAG RevoSpray 3

# Variable-Rate Precision Spraying

Independent control of pump flow rate and droplet size  
Rotary CDA nozzles never clog

---

**50 L**

Smart Tank

---

**1-22 L/min**

Adjustable Flow Rate

---

**5-10 m**

Spray Width

---

**60-400  $\mu\text{m}$**

Droplet Size Range

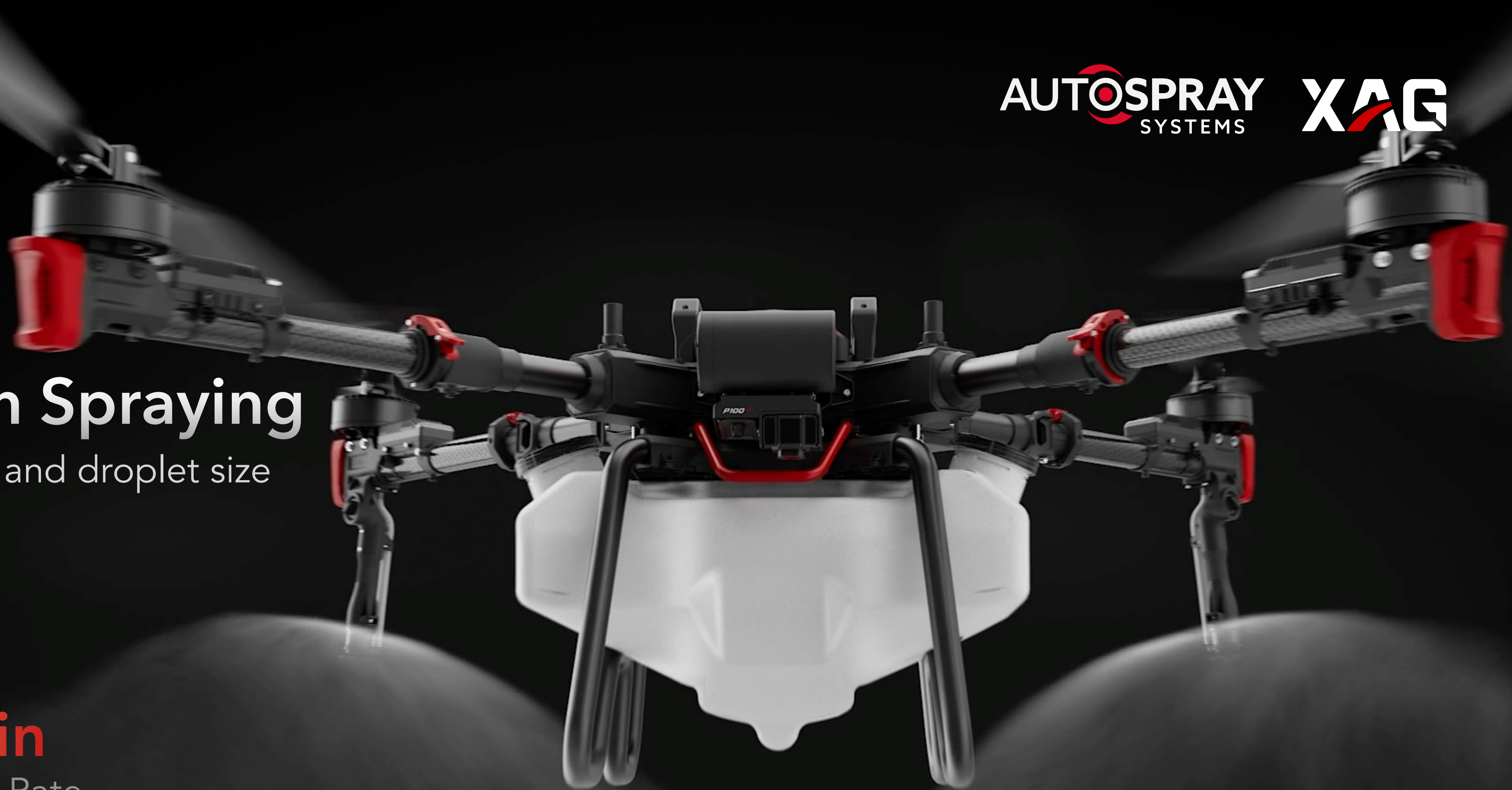

## XAG RevoCast 3

# Seed and Fertilise from the Air

With twin vertical spreading discs and interchangeable augers. The RevoCast 3 can cope with windy conditions with ease

**80 L**

Hopper

**150 kg/min**

Max. Spread Rate

**3-7 m**

Spread Width

**1-6 mm**

Granule Size Range



## XAG One App

# Fully Autonomous Operation on A Smartphone

---

Intelligent Route Planning

---

Operational Data Tracking and Report Sharing

---

Swarm Control Capable

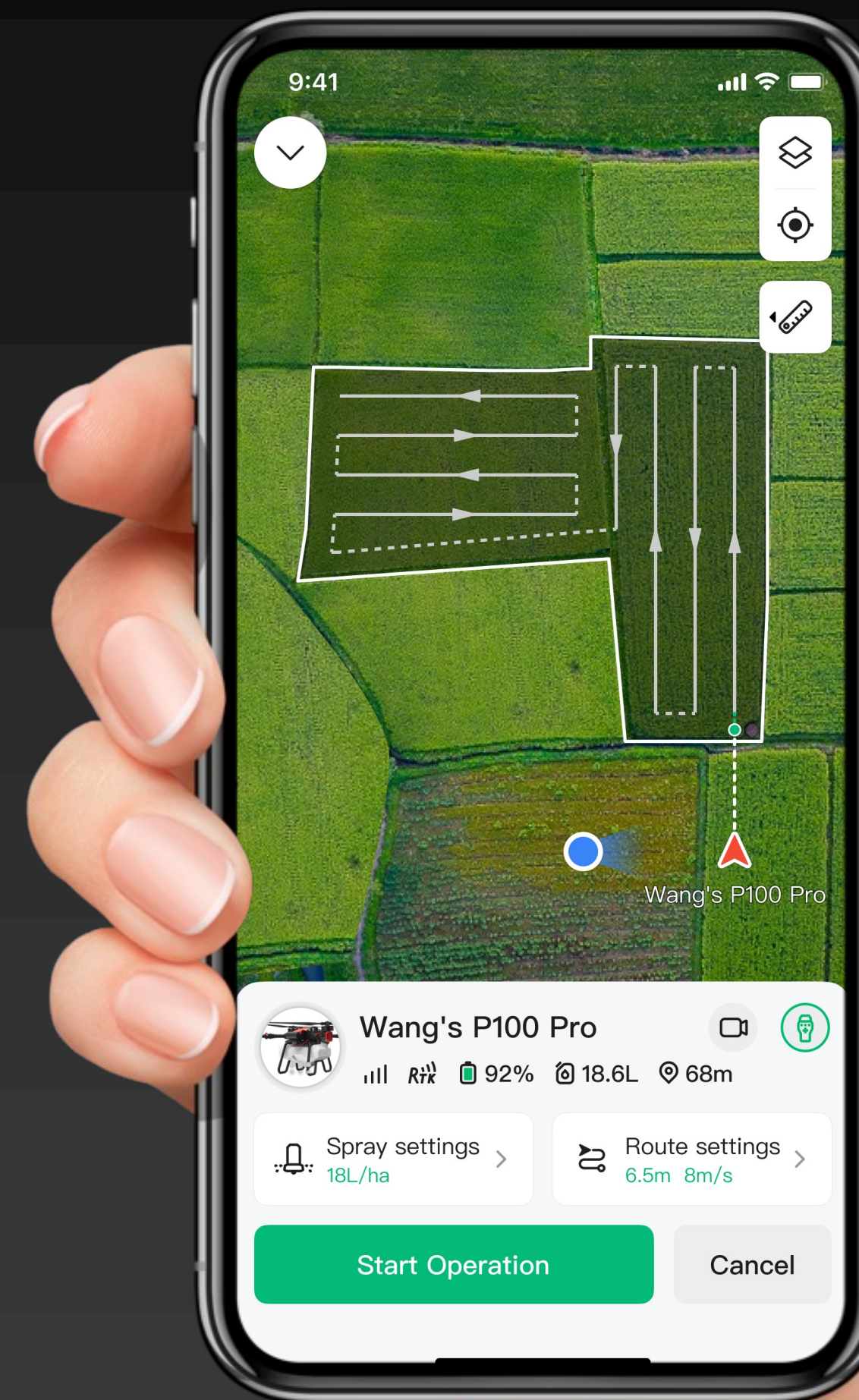

# XAG Agricultural Remote Controller 3 Pro

Designed for agricultural operations. Compact, durable, and user friendly



## Power System Smart Super Charger System

- Water cooled charging system
- Dissipates heat much faster in hot weather
- Self-balancing lithium polymer cell





# Efficiency Taken to the Next Level

## Max. Flow Rate

P100 Pro with RevoSpray 3 **22 L/min**



P100 with RevoSpray 2 **12 L/min**

P100 Pro Crop Protection Efficiency

**19 ha/h**

Open Field

## Max. Granular Spread Rate

P100 Pro with RevoCast 3 **150 kg/min**



P100 with RevoCast 2 **80 kg/min**

P100 Pro Spreading Efficiency

**1300 kg/h**

Fertiliser