



HYDRAULIC WINCH

HEN8000S

HEN8000

HEN10000S

HEN10000

HEN12000

HEN15000

HEN18000

PLEASE READ CAREFULLY BEFORE OPERATE THE WINCH



1689 Xianyuan Road, Jinhua, Zhejiang, China
Tel:0086-579-82262697
Fax:0086-579-82262706
<http://www.nowwinch.net>
E-mail: info@nowvow.net

Safety Warnings and Precautions



WARNING When using the winch, basic safety precautions should always be followed to reduce the risk of personal injury and damage to the equipment. Read all this instructions before using this winch!

1. Keep children away. Children must never be allowed in the work area. Do not let them handle machines, tools, or extension cords.
2. Store idle equipment. When not in use, tools must be stored in a dry location to inhibit rust. Always lock up tools and keep out of reach of children.
3. Dress properly. Do not wear loose clothing or jewelry as they can be caught in moving parts. Protective, electrically non-conductive clothes and non-skid footwear are recommended when working. Wear restrictive hair covering to contain long hair.
4. Use eye and ear protection. Always wear impact safety goggles. Wear a full face shield if you are producing metal filings or wood chips. Wear a dust mask or respirator when working around metal, wood, and chemical dusts and mists.
5. Maintain tools with care. Keep tools sharp and clean for better and safer performance. Follow instructions for lubricating and changing accessories. Inspect tool cords periodically and, if damaged, have them repaired by an authorized technician. The handles must be kept clean, dry, and free from oil and grease at all times.
6. Disconnect switch. Unplug switch when not in use.
7. Stay alert. Watch what you are doing, use common sense. Do not operate any tools when you are tired.
8. Check for damaged parts. Before using any tool, any part that appears damaged should be carefully checked to determine that it will operate properly and perform its intended function. Check for alignment and binding of moving parts; any broken parts or mounting fixtures; and any other condition that may affect proper operation. Any part that is damaged should be properly repaired or replaced by a qualified technician. Do not start the winch if switch does not turn ON or OFF properly.
9. Replacement parts and accessories. When servicing, use only identical replacement parts. Use of any other parts will void the warranty. Only use accessories intended for this winch.
10. Do not operate winch if under the influence of alcohol or drugs. Read warning labels on prescription to determine if your judgment or reflexes are impaired while taking drugs. If there is any doubt, do not operate the winch.

Winch Warnings and Precautions

1. Keeps hands and body away form fairlead (cable intake slot) when operating.
2. Secure vehicle in position before using winch.
3. Be certain winch is properly bolted to a structure (or vehicle) that can hold the winch load.
4. Do not use inappropriate attachments to extent the length of the winch cable.

5. Never lift people or hoist loads over people.
6. It is important that lay a blanket or jacket over the wire rope near the hook end when puling loads. This will slow the snap-back of a broken wire rope and help to prevent serious injury and damage.
7. Avoid continuous pulls from extreme angles because this will cause the wire rope to pile up on one end of the drum and damage the wire rope.
8. Never come in between the winch and the load when operating.
9. After moving an item with the winch, secure the item. Do not rely on the winch to hold it for an extended period.

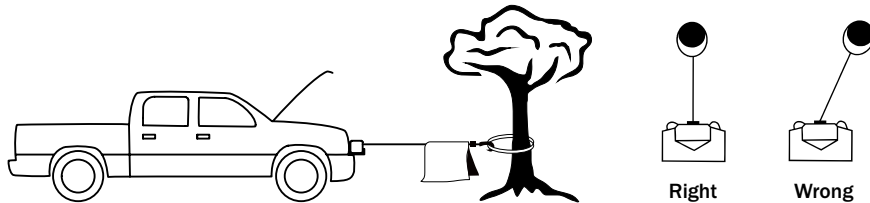

10. Examine winch before using. Components may be affected by exposure to chemicals, salts, and rust.
11. Never fully extent cable while under load. Keep 5 complete turns of cable around the winch drum.
12. Never operate winch if cable shows any signs of weakening, knots or kinks.
13. Winch does not have a locking mechanism. Secure load after moving.
14. Do not cross over or under cable under load.
15. Do not move vehicle with cable extended and attached to load to pull it. The cable could snap.
16. Use gloves while handling cable.
17. Apply blocks to vehicle when parking on an incline.
18. Re-spool cable properly.

Unpacking

When unpacking, check to make sure all parts is included. Refer to Winch Assembly Drawing and Parts List (both with respective item numbers) at the end of this manual.

Installation

1. Mount clutch handle to the clutch assembly, screw as tight as possibly by hand.
2. Mount winch to the vehicle by using high strength cap screws. It should be aligned and secured to a solid part of the vehicle (front or rear) where the full rated load will be evenly distributed.
3. Connect the two-color (positive) battery cables from the female connector to screw-down positive (+) terminal of the 12/24V battery.
4. Please refer to installation illustration.



Nowvow mechanical & electrical Corp., Ltd (Novawinch brand owner) offers a limited lifetime warranty on the mechanical components to authorised distributor & dealer of the winch subject to the following:

Novawinch Limited Lifetime Warranty:

The winch is used for permitted application use only.(expect design for it)

The limited lifetime warranty covers the purchaser of the winch against manufacturing defects in workmanship and materials on all mechanical components.

Mechanical components and associated parts have a lifetime warranty.

Hydraulic motors, valves and associated parts have a limited two (2) year warranty.

The warranty does not apply to the finish of the winch or components.

The owner will be responsible for removing the winch and returning it to an approved Novawinch authorised distributor or dealer within the warranty period.

All freight or delivery charges from the authorised distributor or dealer must be paid for by the owner of the winch unless specified by an authorised distributor or dealer.

Novawinch will not be liable for any fees, costs or charges associated from the removal or installation of the winch, whether or not the winch is under warranty.

Novawinch will repair or replace any or all of the faulty winch components, after an inspection by an authorised distributor or dealer has determined that some or all parts of the winch are defective hence are deemed to be replaced or fixed under warranty.

Novawinch Warranty Exclusions:

There are certain conditions that make the winch not eligible for warranty claims. The warranty is void if, but not limited to the following:

The winch is used inappropriate applications.

The steel rope and synthetic rope are excluded from this warranty, unless specified otherwise by Novawinch, at the discretion of Novawinch.

The winch is damaged in any way from corrosion or water ingress.

The winch is returned in pieces.

The winch has been modified or disassembled resulting in failure.

Any winch component shows signs of normal wear and tear, damage from an accident, abuse, misuse, collision, overloading, modification, misapplication, improper installation or improper service or maintenance.

The winch was not purchased through the Novawinch Authorised Dealer Network.

**The warranty set forth above is the only warranty. Novawinch reserves the right to change the product design at any time without notice. Where this has happened, Novawinch shall have no obligation to upgrade or otherwise modify any previously manufactured products.*

Gearbox Assembly	25	Nylon washer	1
	26	Seal ring	1
	33	1st stage gear shaft	1
	34	Gearbox housing	1
	35	Seal II	2
	36	2nd stage gear ring	1
	37	2nd planetary gear assembly	1
	38	1st stage gear ring	1
	39	Retaining ring for bore, 145	1
	40	Nylon thrust washer I	1
	41	1st planetary gear assembly	1
	42	Nylon thrust washer II	1
	43	Sliding bearing	1
	44	Thrust washer	1
	46	Gear box frame	1
48	Hexagon socket screw	8	
49	Spring washer 6	8	
Clutch Assembly	45	Clutch assembly	1
	47	Hexagon socket set screws with sharp point, M4x8	1
Accessories	50	Cable(optional)	1
	51	Hook Assembly and Hand Saver(optional)	1
	52	Fairlead(optional)	1
	53	Hardware	1ST
	54	Wire rope tensioner(optional)	1

MOUNTING

The diagrams show the mounting dimensions for the 8000-18000lbs.

The side and feet mounting hole positions are designed to allow the winch to be interchangeable with the most popular 8000-18000lbs units currently available. The diagram below shows the 8000-18000lbs mounted on a flatbed mounting kit, shown with Roller Fairlead. If a mounting plate is not used, the surface must be flat within 0.5 mm (0.015 inch) and sufficiently stiff to prevent flexing. A minimum of 6.0 mm (0.25 inch) thick steel plate should be used. The thicker the plate, the better the alignment the better the alignment between motor mounting, drum and gearbox housing.

It is important that the winch is mounted securely so that the motor mounting, drum and gearbox housing are accurately aligned. Be sure the winch will not move under load, otherwise you may cause misalignment in the winch, causing the drum to bind up.

The tie bars supplied with the winch must remain attached when the winch is foot mounted.

Angle mounting is possible and recommended for maximum flexibility in mounting.

These mounts allow the winch to be low-mounted. See the diagram below.

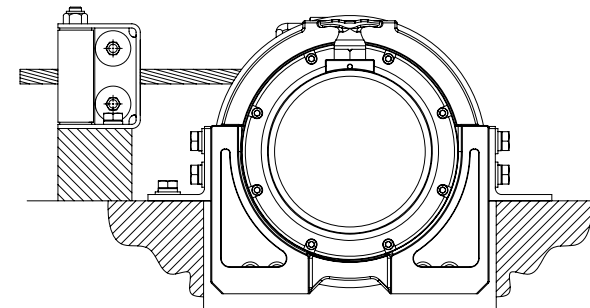
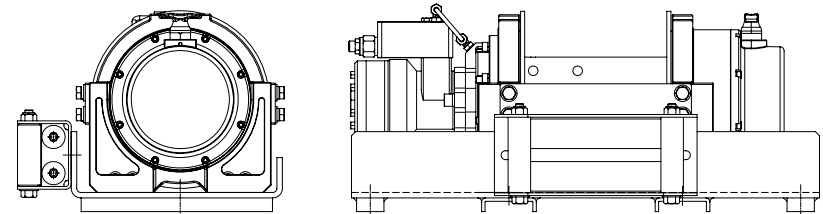

Mounting the directional solenoid valve assembly

The valve should be mounted away from any areas where heat may be considered too extreme. Such as an exhaust manifold or turbo. Be sure all plumbing and wiring reaches from the area selected without being stressed. It may be mounted by using the bracket and Allen screws supplied. Using the bracket as a guide, mark the location of where the mounting holes are going to be drilled, remove the plate and drill four 1/4" holes. Mount valve assembly using nuts, bolts.

Note: On some vehicles grill may have to be removed to install plumbing and wiring for the winch.

Mounting the balance valve

The balance valve you obtained (it's optional) is simply connected to motor. If your winch system installs a balance valve as complete working mode, be sure the balance valve's installing direction meets hydraulic principle chart. Otherwise, the winch will not reach the rated line pull, and it is also dangerous for winch to power off the cable with heavy load. If this symptom happens, simply disconnect the balance valve, exchange the oil hole between hydraulic motor and balance valve, and reconnect it. If you ordered, then the balance valve should be supplied. It will have been connected with the motor at the factory.

Electrical connections

If winch's power supply is from the vehicle's exiting power steering pump, the solenoid valve system is designed to default to the power steering box so power steering is always available even when the winch is in use. The power source to the solenoid is not energized until the three-pole quick connector plug is plugged in. Each solenoid has two wires—either of which can be used as a ground or for electric power. The grounds are connected to each other at the factory. The other will connect to the blue and yellow wire in the harness (see illustration) . Determine a location on the front grill to mount the female 3 pole plug connector. Drill a hole and mount the female 3 pole plug connector using nuts, bolts and washers supplied. Connect all wiring as shown in illustration. Test hand control unit, solenoids will make a slight "click" sound if connected properly.

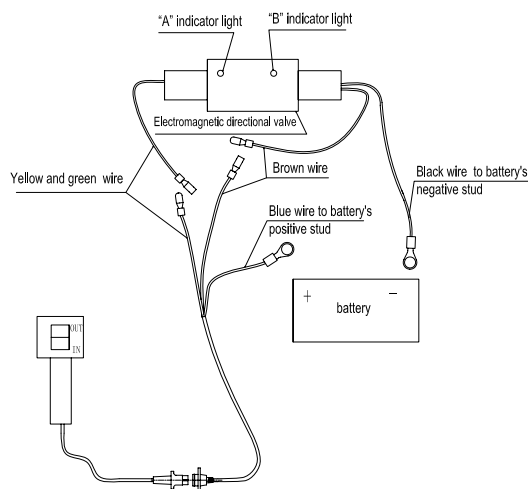

HEN8000S-HEN18000

Assembly	Item	Description	Qty	
Hydraulic Motor & Valve Assembly	3	Hexagon socket screw M12×35	2	
	4	Spring washer φ12	2	
	5	Hexagon socket screw M8×60	4	
	6	U-tube	1	
	7	Adaptor	2	
	8	Block load control	1	
	9	O-ring φ17×φ2.65	2	
	10	Hydraulic motor	1	
	11	O-ring φ82×φ2.65	2	
	12	M7 bleed nipple	1	
	Hydraulic Brake Assembly	1	Hexagon socket screw M8×35	8
		2	Spring washer φ8	8
13		Motor mounting plate	1	
14		O-ring φ155×φ3.1	1	
15		U-seal	1	
16		Stationary disc	3	
17		Rotating disc	2	
18		Rotor	1	
19		Thrust washer	1	
20		Pressure plate	1	
21		Disc spring	2	
22		Supporting ring	1	
23		Motor frame	1	
24		Gasket	1	
25		Nylon washer	1	
26		Seal ring	1	
Tie Bar Assembly	27	Screw M12×25	8	
	28	Spring washer φ12	8	
	29	Plain washer φ12	8	
	30	Tie Bar	2	
Drum Assembly	31	Drum	1	
	32	Hexagon socket set screws with fat point, M8×8	1	
	24	Gasket	1	

HEN8000S-HEN18000 Winch Assembly Drawing

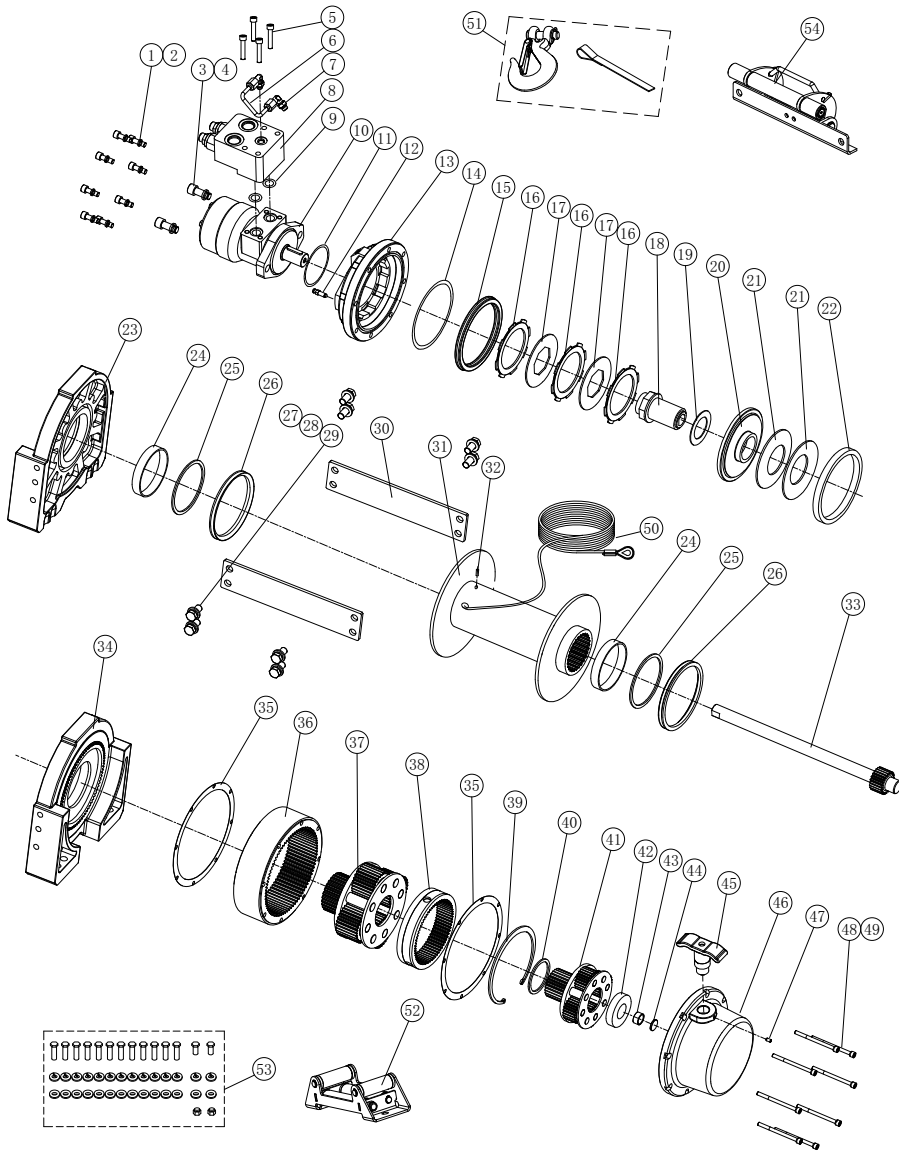

Plumbing connections

Keep all hoses away from any areas where heat may be considered too extreme such as an exhaust manifold or turbo. Lines should not be allowed to rub on any abrasive or vibrating surfaces. In some applications, right angle fittings on the directional valve and motor or balance valve are necessary to make hose mounting more flexible. After plumbing has been laid out on vehicle, install o-ring fitting supplied to valve. Torque tight. **DO NOT OVERTIGHTEN ANY FITTINGS.** Install o-ring fitting on winch motor. Torque tight. Connect any hose to port A on motor or port C1 on balance valve to port A on directional valve, port B on motor or port C2 on balance valve to port B on directional valve, port P on directional valve to pump's high pressure port, port T on valve to reservoir. Attach any o-ring or seal from vehicles original tube fitting to tube fitting.

Hydraulic system requirements

Refer to the performance charts below to properly match your hydraulic system to the winch performance.

A motor spool directional control valve is recommended.

HEN8000-15000:

SYSTEM REQUIREMENTS:
 2000 PSI RELIEF VALVE SETTING
 15 G.P.M. FLOW RATE *
 10 MICRON NORMAL FILTRATION

*Caution: Do not exceed 15 G.P.M. If exceeded, motor and winch may be damaged.

HEN18000:

SYSTEM REQUIREMENTS:
 2500 PSI RELIEF VALVE SETTING
 20 G.P.M. FLOW RATE *
 10 MICRON NORMAL FILTRATION

*Caution: Do not exceed 20 G.P.M. If exceeded, motor and winch may be damaged.

Working hydraulic principle chart:

Without load control

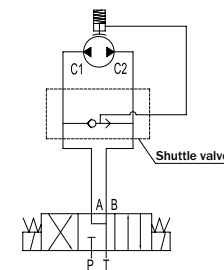

With load control

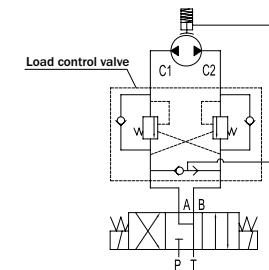

Typical layout

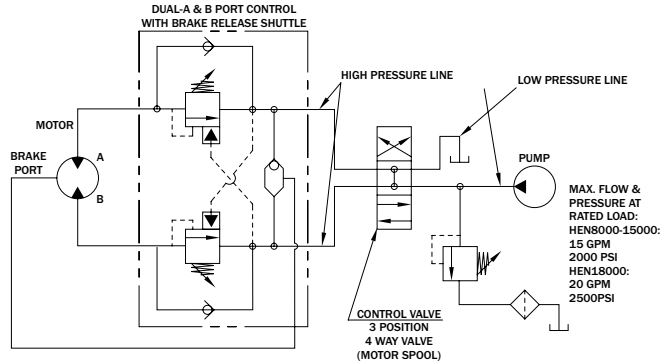

CAUTION Battery cables should not be drawn taut, leave slack for some cable movement.

If your application is supplied with an added cooler, please refer to illustration. Check fluid level. Replace lost fluid to system. System will need to be purged. Start engine. Power winch cable in 5 feet. Shut engine off. Check fluid level. (Add fluid until full. start engine. power winch cable. Out 5 feet. Shut engine off. Check fluid level.) Add fluid until full if necessary. Start engine. Power winch cable into desired position. Turn vehicle wheels from lock to lock position 5 times. This will aid in bleeding out any air that may have got into the system.

If the hand control unit is working backwards, simply exchange the brown and white wire connectors.

Winch cable must be wound onto the drum under a load of at least 10% rated line pull or outer wraps will draw into inner wraps and damage winch cable.

Test winch for proper operation. Refer to the operation section below.

WARNINGS!

1. Make sure the clutch is totally engaged before starting any winch operation;
2. Stay clear and away from raised loads;
3. Stay clear of cable while pulling do not try to guide cable;
4. A min. of 5 wraps of cable around the drum.

General information

The winch's standard equipments contain gear reducer, drum, hydraulic motor, solenoid valve, switch assembly, female connector and plumbing fittings. The winch obtains its pressure from the vehicle's existing power steering pump or other hydraulic power. The winch is totally sealed, can be used underwater.

There are several ways to supply the pressure for winch. The first way: use an individual

15000lb Winch Line Pull And Pressure Difference						
Single line pull	lbs	0	4000	8000	12000	15000
	kg	0	1816	3632	5448	6810
Pressure difference between Motor entry and exit	MPa	8	9.5	11	12.5	15

18000lb Winch Performance Specification	
Rated line pull	18000lbs(8172kg)
Gear ratio	17.3:1
Max flow	75L/min
Max pressure	17MPa
Motor displacement	200ml/r
Wire rope	35/64"×98.4'(φ14mm×30m)
Drum size	5"×8.2"(φ126×208mm)
Overall dimensions	25.1"×11.9"×10.9"(637×304×276mm)
Bolt pattern	10"×4.5"(254×114.3mm) 10"×6.5"(254×165.1mm) 10"×8.5"(254×215.9mm)
Net weight	167.4lb(76kg)

18000lb Winch Line Pull And Cable Capacity					
Layer of cable		1	2	3	4
Rated line pull per layer	lbs	18000	15000	12857	11250
	kg	8172	6810	5832	5103
Line speed	Ft/min	22.9	27.5	32.1	36.7
	m/min	7.0	8.4	9.8	11.2
Cable capacity per layer	Ft.	20.0	44.0	71.9	98.4
	m	6.1	13.4	21.9	30

18000lb Winch Line Pull And Pressure Difference						
Single line pull	lbs	0	8000	12000	15000	18000
	kg	0	3632	5448	6810	8172
Pressure difference between Motor entry and exit	MPa	8	11	12.5	14	17

12000-15000lb Winch Performance Specification		
	HEN12000	HEN15000
Rated line pull	12000lbs(5448kg)	15000lbs(6810kg)
Gear ratio	17.3:1	17.3:1
Max flow	60L/min	60L/min
Max pressure	14MPa	15MPa
Motor displacement	160ml/r	200ml/r
Wire rope	15/32"×98.4'(φ12mm×30m)	1/2"×98.4'(φ13mm×30m)
Drum size	4.6"×8.2"(φ117×208mm)	5"×8.2"(φ126×208mm)
Overall dimensions	24.7"×11.9"×10.4" (627×304×265mm)	24.8"×11.9"×10.4" (630×304×265mm)
Bolt pattern	10"×4.5"(254×114.3mm) 10"×6.5"(254×165.1mm) 10"×8.5"(254×215.9mm)	10"×4.5"(254×114.3mm) 10"×6.5"(254×165.1mm) 10"×8.5"(254×215.9mm)
Net weight	150lb(68kg)	161lb(73kg)

12000lb Winch Line Pull And Cable Capacity					
Layer of cable		1	2	3	4
Rated line pull per layer	lbs	12000	10118	8746	7701
	kg	5448	4589	3967	3493
Line speed	Ft/min	19.7	23.3	26.9	30.5
	m/min	6	7.1	8.2	9.3
Cable capacity per layer	Ft.	21.6	48.9	76.8	98.4
	m	6.6	14.9	23.4	30

15000lb Winch Line Pull And Cable Capacity					
Layer of cable		1	2	3	4
Rated line pull per layer	lbs	15000	12636	10916	9608
	kg	6810	5732	4952	4358
Line speed	Ft/min	18.0	21.3	24.9	28.2
	m/min	5.5	6.5	7.6	8.6
Cable capacity per layer	Ft.	21.3	48.6	76.1	98.4
	m	6.5	14.8	23.2	30

12000lb Winch Line Pull And Pressure Difference						
Single line pull	lbs	0	4000	8000	12000	/
	kg	0	1816	3632	5448	/
Pressure difference between Motor entry and exit	MPa	8	9.5	11	14	/

pump for engineering use; the second way: the winch's pressure is from the vehicle's exiting power steering pump as installation illustration:

- (1) Use a suitable individual pump which has no oil valve. It supplies pressure for both steering box and winch.
- (2) Use a combined pump which integrates an oil valve. The oil valve supplies two kinds of flow for different demand, one with constant flow is for steering use, the other with higher power is for engineering use. Refer to installation. You can choice the best suitable way.

If your winch is installed as a simple working mode (standard supplied), NEVER POWER WINCH CABLE OUT WITH HEAVY LOAD, that will be very dangerous. If your winch is installed with a balance valve as a complete working mode, you can power winch cable in and out under heavy load even lifting.

1. Disengage the clutch by turning the clutch to the "out" position.
2. Grab the Cable and hook assembly and pull the cable to the desired length, then attach to item being pulled.



CAUTION always leave at least five turns of cable on the drum. Review winch Safety Warnings and Precaution before continuing.

3. Re-engage the clutch by turn the clutch to the "in" position. If necessary to turn the drum make a slight "click" sound while engaged properly, then turn the clutch tight.
4. Lift the female connector cover exposing the electric switch connector.
5. Insert the switch assembly connector on to the female connector.
6. While standing aside of the towing path, press (and hold) the push button on the switch assembly. Press (and hold) the opposite push button to reverse directions. Wait until the motor stops before reversing directions.
7. When the towing is complete remove the switch assembly. From the female connector and replace the female connector's cover.

Maintenance

It is highly recommended and that the winch be used regularly (once a month). Simply power the cable out 15m, free spool 5m and then power back in. This will keep all components in good working condition so that the winch can be relied on when needed. Contact your authorized outlet for technical assistance and repairs.

Trouble shooting

SYMPTOM	POSSIBLE CAUSE	SUGGESTED ACTION
Winch does not turn	-Insufficiently hydraulic system pressure. -Improper connections of hydraulic system, no oil into motor.	-Check relief valve regulate pressure. -Check all the plumbing fixtures according to the working principle chart. -Defective directional control valve.

Motor runs but Cable drum does not turn	-The clutch is Not engaged.	-Turn the clutch to the high or lows peed position. If problem still persists, a qualified technician needed to check and repair.
Winch drum runs slowly or without normal power	-Insufficient pressure or oil flow. -Insufficient fluid in the system. -Wrong winch working direction.	-Bump is not suitable or defective. Change a new one or a suitable one -Check fluid level. Add fluid until full. -Change the connection of balance valve and motor.
Winch cannot spool off wire rope with load smoothly	-Wrong winch working direction.	-Change the connection of balance valve and motor.

Lubrication

1. All moving parts within the winch having been lubricated using high temperature lithium grease at the factory. No internal lubrication is required.
2. Lubricate cable assembly periodically using light penetrating oil.

Cable Assembly Replacement

1. Turning clutch to the "Clutch Out" position.
2. Extend cable assembly to its full length. Pay attention to how the existing cable is connected to the drum.
3. Remove old cable assembly and attach new one.
4. Retract cable assembly onto drum, first five wraps being careful not to allow kinking of the winch cable must be wound onto the drum under a load of at least 10% rated line pull.
5. The roller fairlead is to be mounted so as to guide the rope onto the drum evenly.

Pulling out the rope

Dis-engage the freespool. With a pair of gloves on, pull out the rope and secure to anchor or load. Re-engage the freespool.

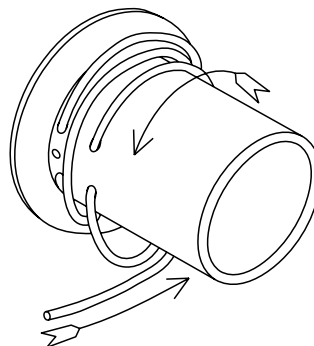

10000lb Winch Performance Specification		
	HEN10000	HEN10000S
Rated line pull	10000lbs(4540kg)	10000lbs(4540kg)
Gear ratio	16.9:1	16.9:1
Max flow	60L/min	60L/min
Max pressure	13MPa	13MPa
Motor displacement	125mL/r	125mL/r
Wire rope	13/32"×97.4'(φ10.3×30m)	13/32"×82'(φ10.3×25m)
Drum size	3.54"×8.66 "(φ90×220mm)	3.54"×7.48 "(φ90×190mm)
Overall dimensions	25"×9.84"×9.45" (634×250×240mm)	23.7"×9.84"×9.53" (602×250×242mm)
Bolt pattern	10"×4.5"(254×114.3mm) 10"×6.5"(254×165.1mm)	8.74"×4.5"(222×114.3mm) 8.74"×6.5"(222×165.1mm)
Net weight	110lb(50kg)	108lb(49kg)

10000lb Winch Line Pull And Cable Capacity							
		Layer of cable		1	2	3	4
Rated line pull per layer	HEN10000	lbs	10000	8296	7088	6188	
		kg	4540	3763	3215	2807	
	HEN10000S	lbs	10000	8296	7088	6188	
		kg	4540	3763	3215	2807	
Line speed	HEN10000	Ft/min	19.7	23.6	27.6	31.5	
		m/min	6.0	7.2	8.4	9.6	
	HEN10000S	Ft/min	19.7	23.6	27.6	31.5	
		m/min	6.0	7.2	8.4	9.6	
Cable capacity per layer	HEN10000	Ft.	22.0	47.6	75.8	98.4	
		m	6.7	14.5	23.1	30	
	HEN10000S	Ft.	19.0	40.8	64.8	82.0	
		m	5.8	12.4	19.7	25.0	

10000lb Winch Line Pull And Pressure Difference						
Single line pull	lbs	0	4000	6000	8000	10000
	kg	0	1816	2724	3632	4540
Pressure difference between Motor entry and exit	MPa	8	9.5	10	11	13

8000lb Winch Performance Specification		
	HEN8000	HEN8000S
Rated line pull	8000lbs(3632kg)	8000lbs(3632kg)
Gear ratio	16.9:1	16.9:1
Max flow	60L/min	60L/min
Max pressure	14MPa	14MPa
Motor displacement	80mL/r	80mL/r
Wire rope	3/8"×114.8'(φ9.2×35m)	3/8"×82'(φ9.2×25m)
Drum size	3.54"×8.66 "(φ90×220mm)	3.54"×7.48 "(φ90×190mm)
Overall dimensions	25"×9.84"×9.45" (634×250×240mm)	23.7"×9.84"×9.53" (602×250×242mm)
Bolt pattern	10"×4.5"(254×114.3mm) 10"×6.5"(254×165.1mm)	8.74"×4.5"(222×114.3mm) 8.74"×6.5"(222×165.1mm)
Net weight	108lb(49kg)	106lb(48kg)

8000lb Winch Line Pull And Cable Capacity						
Layer of cable			1	2	3	4
Rated line pull per layer	HEN8000	lbs	8000	6748	5835	5140
		kg	3632	3061	2647	2332
	HEN8000S	lbs	8000	6748	5835	5140
		kg	3632	3061	2647	2332
Line speed	HEN8000	Ft/min	27.9	33.1	38.4	43.3
		m/min	8.5	10.1	11.7	13.2
	HEN8000S	Ft/min	27.9	33.1	38.4	43.3
		m/min	8.5	10.1	11.7	13.2
Cable capacity per layer	HEN8000	Ft.	24.3	52.2	83.0	114.8
		m	7.4	15.9	25.3	35.0
	HEN8000S	Ft.	21.1	44.9	71.0	82.0
		m	6.4	13.7	21.6	25.0

8000lb Winch Line Pull And Pressure Difference						
Single line pull	lbs	0	4000	5000	6000	8000
	kg	0	1816	2270	2724	3632
Pressure difference between Motor entry and exit	MPa	8	10	10.5	11.5	14

HEN8000S/HEN10000S

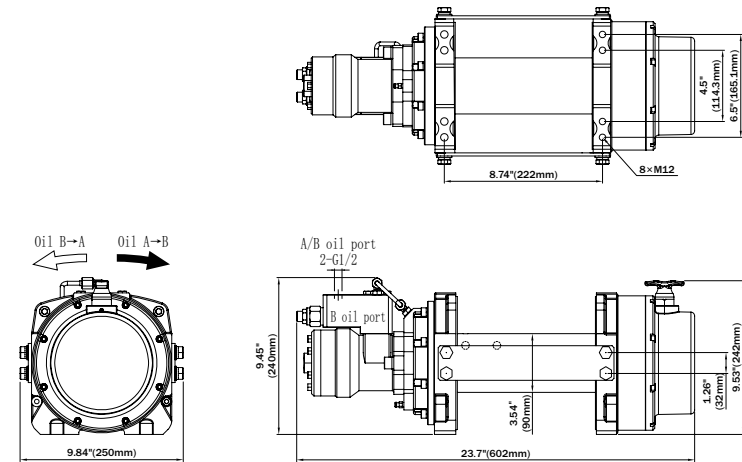

HEN8000/HEN10000

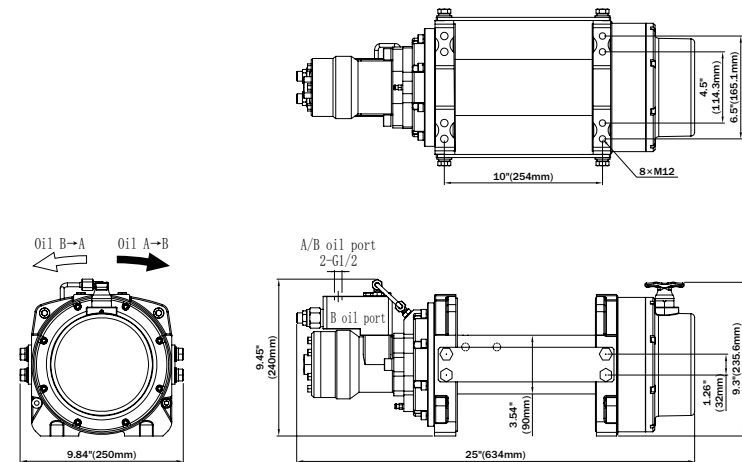

HEN12000

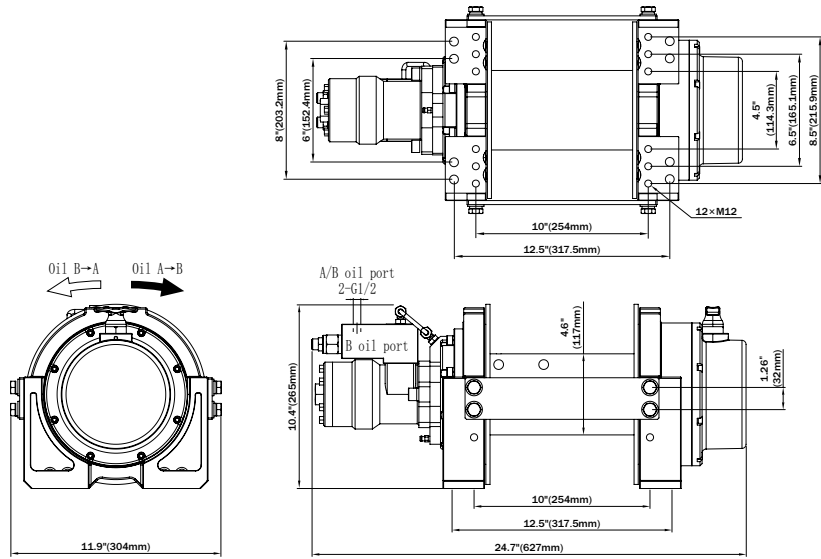

HEN18000

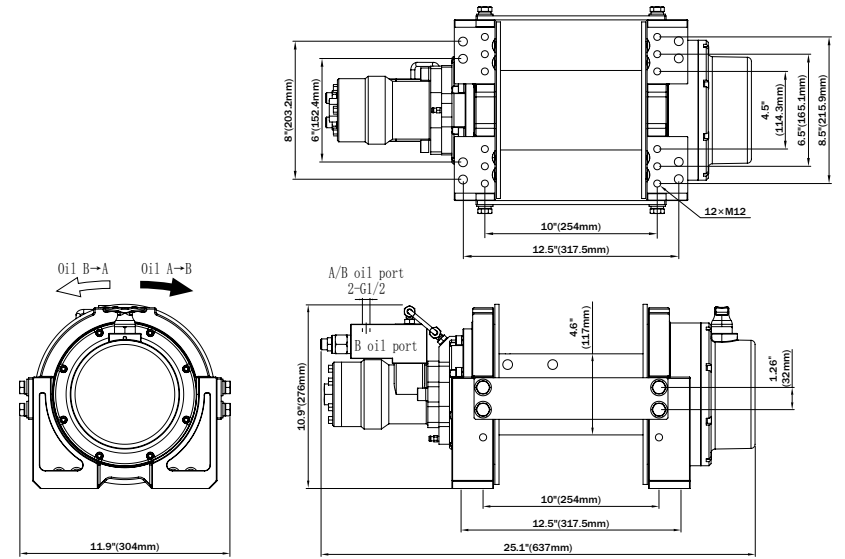

HEN15000

