

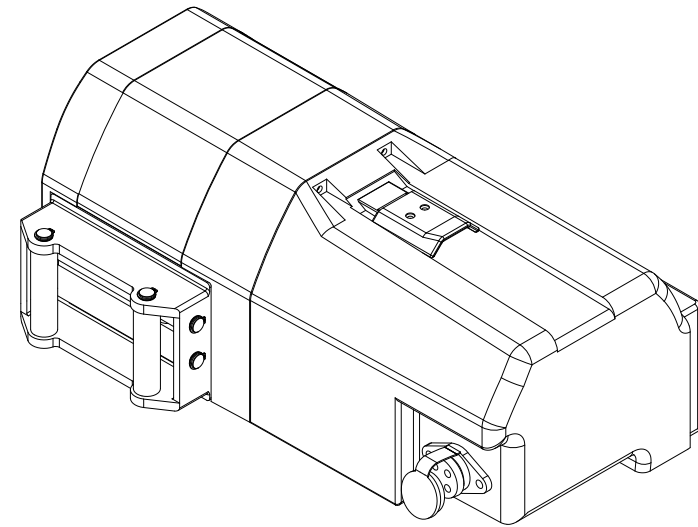

12 & 24 VOLT DC ELECTRIC WINCHES



U4000 & 5000

OWNER'S MANUAL

READ CAREFULLY BEFORE OPERATION

Zhejiang NOWVOW Mechanical & Electrical Corp.,Ltd

1689 Xianyuan Road, Jinhua, Zhejiang, China
Tel:0086-579-82262697 Fax:0086-579-82262706
E-mail:info@nowvow.net
www.novawinch.net

Revision Date 2019-06-01

INTRODUCTION

Please read and understand this Owner's Manual before installing your winch. Pay particular attention to the General Safety Information. Your winch is a very powerful machine. If used unsafely or improperly, there is a possibility that property damage or personal injury could result. We have included several features in the winch to minimize this possibility; however, your safety ultimately depends on your caution when using this product.

SAFETY PRECAUTIONS

The responsibility for safe operation of this winch ultimately rests with you, the operator. Read and understand all safety precautions and operating instructions before installing and operating the winch. Careless winch operation can result in serious injury and/or property damage.

Throughout this manual, you will find notations with the following headings:



Indicates an imminently hazardous situation which, if not avoided, will result in death or serious injury.



Indicates a potentially hazardous situation which, if not avoided, could result in death or serious injury.



Indicates a potentially hazardous situation which, if not avoided, may result in minor or moderate injury. This notation is also used to alert against unsafe practices.

The following symbols on the product and in the Owner's manual are used:



Read Owner's Manual

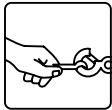

Always Use Handsaver

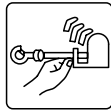

Keep clear of winch, wire rope and hook while operating



Never use winch to lift or move people



Never use winch to hold loads in place

Note: Indicates additional information in the installation and operation procedures of your winch.

Correct installation of your winch is a requirement for proper operation.

Please Note: The Novawinch U series winch is designed primarily for intermittent duty general use. This winch is not designed to be used in industrial or hoisting applications and we do not warrant it to be suitable for such use.

TROUBLESHOOTING CHART

If a problem arises, contact your nearest Novawinch dealer or repair center.

Symptom	Possible Cause(s)	Corrective Action
Motor will not operate or runs in one direction only	<ol style="list-style-type: none"> 1. Damaged or stuck solenoid 2. Switch inoperative 3. Broken wires or bad connection 4. Damaged motor 5. Solenoids not grounded 	<ol style="list-style-type: none"> 1. Disengage clutch before performing this test to prevent pow-ering the wire rope drum. If a solenoid sticks once, it is likely to stick again and must be replaced immediately. Tap solenoid to free stuck contacts. Check by applying voltage to the small solenoid terminal. Be sure solenoid is grounded back to source. A sole-noid that is not stuck will make an audible "click" when first energized. 2. Replace switch 3. Check for poor connections: Always use 2 wrenches (spanners)(Figure 11) 4. Replace or repair motor 5. Check the ground path between battery nega-tive and solenoid base
Winch will not shut off	<ol style="list-style-type: none"> 1. Solenoid stuck "On" 	<ol style="list-style-type: none"> 1. If a solenoid sticks on, reverse direction and hold trigger switch until the power lead can be disconnected. A safety disconnect switch is avail-able as an accessory
Motor runs extremely hot	<ol style="list-style-type: none"> 1. Long period of operation 2. Damaged motor 3. Damaged brake 	<ol style="list-style-type: none"> 1. Allow to cool 2. Replace or repair motor 3. Replace or repair brake
Motor runs but with insufficient power or line speed	<ol style="list-style-type: none"> 1. Weak battery 2. Battery to winch wire too long 3. Poor battery connection 4. Poor ground 5. Damaged brake 	<ol style="list-style-type: none"> 1. Recharge or replace battery. Check charging system 2. Use larger diameter wire 3. Check battery terminals for corrosion. Clean as required 4. Check and clean connections 5. Repair or replace brake
Motor runs but drum doesn't turn	<ol style="list-style-type: none"> 1. Clutch not engaged 	<ol style="list-style-type: none"> 1. Engage clutch
Winch runs backwards	<ol style="list-style-type: none"> 1. Motor wires reversed 2. Solenoids wired incorrectly 	<ol style="list-style-type: none"> 1. Recheck wiring 2. Recheck wiring
Winch will not hold load	<ol style="list-style-type: none"> 1. Excessive load 2. Worn or damaged brake 	<ol style="list-style-type: none"> 1. Reduce load or double line 2. Repair or replace brake

GENERAL DESCRIPTION

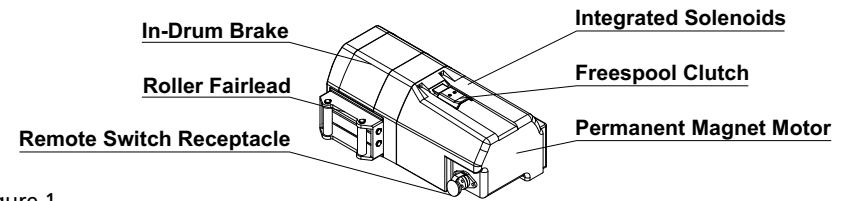

Figure 1

SPECIFICATIONS

U4000

Working Load*	4000 lbs(1814 kgs)
Wire Rope	7/32" x 60'
Motor	12V or 24V DC 1.8 hp (1.34 kW) peak
Gear Ratio	159:1

U5000

Working Load*	5000 lbs (2268 kgs)
Wire Rope	1/4" x 50'
Motor	12V or 24V DC 2.1 hp (1.57 kW) peak
Gear Ratio	159:1

* Based on first layer performance

ROLLING LOAD CAPACITIES

U4000

Slope*	10% (6°)	20% (11°)	30% (17°)	100% (45°)
lbs.**	17588	11905	8138	4499
kgs**	7978	5400	4145	2041

U5000

Slope*	10% (6°)	20% (11°)	30% (17°)	100% (45°)
lbs.**	22613	15306	11749	5784
kgs**	10257	6943	5329	2624

Ratings assume a 10% coefficient of friction.

*A10% slope is a rise of one foot in ten feet. Slope in approximate degrees is also shown above.

**All loads shown are for single-line operation. Double-line operation with optional pulley block (see Figure 3) approximately doubles capacity of winch.

UNPACKING

This carton contains the following items. Please unpack carefully.
Read instructions before beginning.

Description	Quantity
Winch assembly with wire rope including lead wires	1
Circuit breaker assembly with hardware	1
Handsaver	1
Mounting hardware kit	1
Remote pendant	1
Owner's manual	1

DIMENSIONS

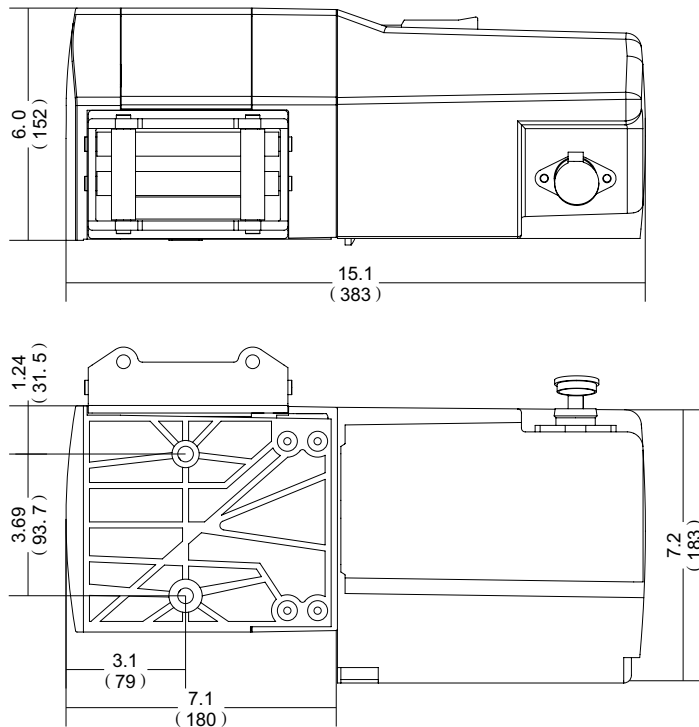

Figure 2

Note: Typical mount is to flat surface capable of handling the loads. Bolts to be Grade 5 or better.

REPLACEMENT PARTS LIST

Item	Description	Qty	Option
1	Base	1	
2	Hexagon Socket Head Cap Screws	2	
3	Flat Washer	2	
4	Cable Guard	1	
5	Main Bearing	1	
6	Drum	1	
7	Brake Spring	1	
8	Brake Adapter	1	
9	Drum Bearing	1	
10	M6x1x16mm Button Head Screw	5	
11	Drum Support	1	
12	Thrust Washer	2	
13	Drive Plate	1	
14	Rotating Ring Gear	1	
15	Stationary Ring Gear	1	
16	Planetary Carrier Assembly	1	
17	Sun Gear	1	
18	Needle Bearing	1	
19	Free Wheel Repair Kit	1	
20	Free Wheel Spring	1	
21	Housing Assembly	1	
22-24	Clutch(Includes Shaft, Lever, and Rivet)	1	
25	Complete Motor	1	
26	Band Clamp	2	
27	Type 6 Solenoid With Bracket	1	
28	Motor Cover	1	
29	M4x0.8x8mm Hex Washer Head Screw	4	
30	Cable Tension Spring	1	
31	Roller Fairlead	1	
32	M6x1x13mm Button Head Screw	2	
33	M6x1x20mm Button Head Screw	4	
34	Socket	1	
35	Cross Recessed Truss Head Screw	2	
36-39	Hardware Screw Set	1	
40	Wire Rope	1	
41	Hook	1	
42	Handsaver	1	
43	Handheld Remote Control	1	
44	Protection Relay Set	1	

WINCH ASSEMBLY

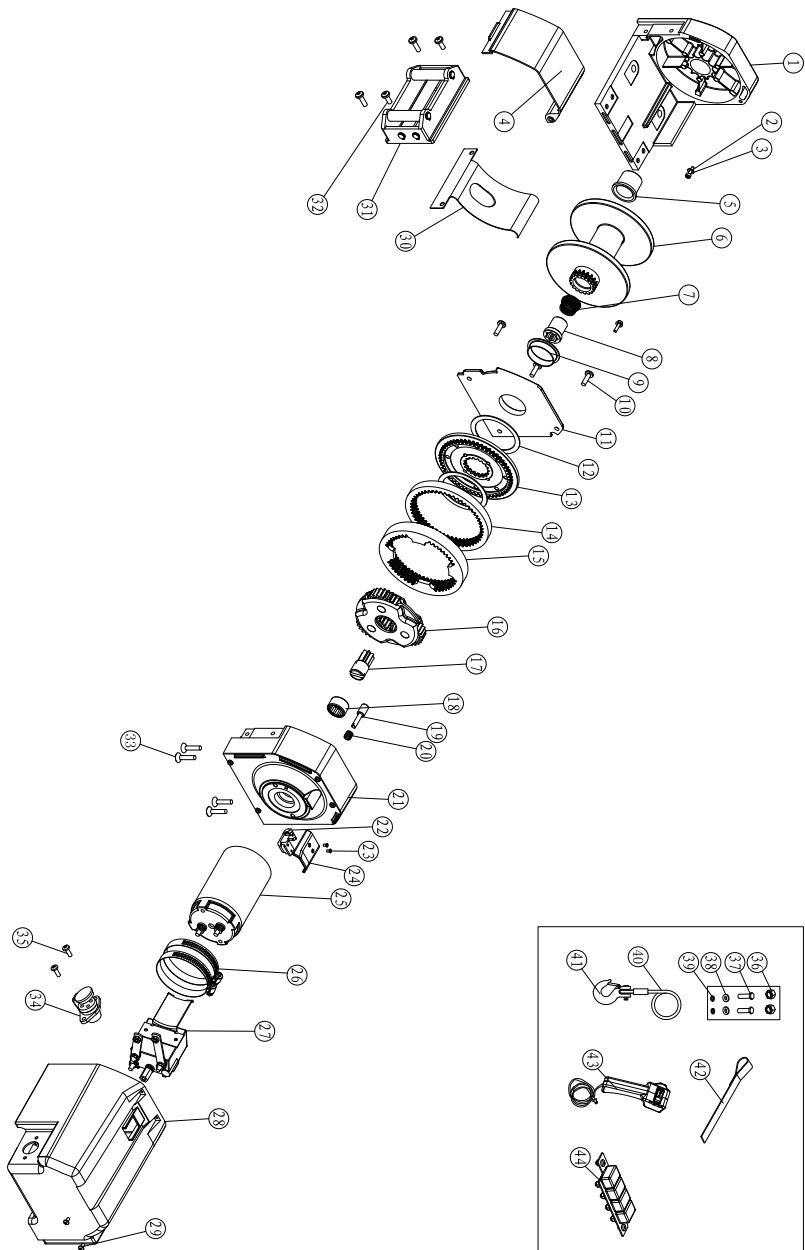

PERFORMANCE

U4000

Wire Rope Layer	Max. Pulling Capacity	
	lbs	kgs
1	4000	1814
2	3000	1361
3	2600	1179
4	2000	907

Load	Speed	Motor Current		
		lbs	kgs	ft/min
0	0	21.6	6.6	30
1000	454	16.0	4.9	90
2000	907	12.4	3.8	155
2500	1134	10.6	3.2	180
3000	1361	8.8	2.7	215
3500	1588	6.2	1.9	250
4000	1814	4.5	1.4	311

U5000

Wire Rope Layer	Max. Pulling Capacity	
	lbs	kgs
1	5000	2268
2	4000	1814
3	3500	1588
4	2900	1315

Load	Speed	Motor Current		
		lbs	kgs	ft/min
0	0	17.5	5.3	36
1000	454	14.5	4.4	80
2000	907	12.0	3.7	135
3000	1361	9.5	2.9	200
4000	1814	7.3	2.2	265
5000	2268	4.5	1.4	350

* Based on first layer performance

INTERMITTENT DUTY

An electric winch is like any other motor driven power tool such as an electric drill or saw. The electric motor should not be allowed to become excessively hot. Normal precautions will extend the life of your motor. Keep the duration of pulls as short as possible. **If the end of the motor becomes uncomfortably hot to touch, stop winching and allow the motor to cool down.**



If the winch motor stalls, do not continue to apply power to the winch.

FEATURES

Electric Motor - 1.8 (S4000), 2.1 (S5000) peak hp, 1.34 (S4000), 1.57 (S5000) kW 12V or 24V Permanent Magnet.

Braking - A wrap spring brake which will hold 50% of rated load on the first wrap. Reducing by approximately 10% per layer thereafter.

Drum - Die cast aluminum running in maintenance free bearings.

Freespool Clutch - Operated by an easy action lever which disengages the gearbox to allow the wire rope to be pulled out without using electric power. A tension plate reduces backlash and snarling when pulling out the wire rope.

Remote Switch - 30'(9.14 m) handheld pendant switch assembly with toggle switch.

Mounting - Optional custom engineered mounting kits are available for vehicle frame attachment.

MAINTENANCE AND REPAIRS

LUBRICATION

The gearbox and drum bearing are permanently lubricated with a high performance gear lube. If relubrication is necessary (after repair or disassembly) only use Shell Alvenia EP2 or equivalent.

REPLACING THE WIRE ROPE

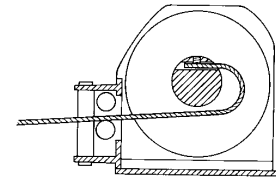

Figure 17

Never substitute a heavier or lighter wire rope. Never use rope made of any material other than wire.

Always replace damaged wire rope with manufacturer's identical replacement part (see Replacement Parts list). Pass attaching end of wire rope through the fairlead (if equipped) and attach it to the drum. When inserting the wire rope into the drum, insert it into the correct end of the hole provided (Figure 17). Tighten the set screw securely. It is important that the wire rope be wound tightly onto the drum. A good way to do this is to attach the wire rope hook to a fixed object at the top of a slight incline, then winch the vehicle up the incline.

BRAKE OPERATION

Your U Series winch has a wrap spring brake that stops and holds loads up to 50% rated capacity on the first layer of wire rope closest to drum.

Each additional layer of wire rope reduces brake capacity approximately 10%. When powering the winch in, the brake is disengaged and does not become activated until the motor is turned off and the load tries to pull the wire rope off the drum. When the winch is powered out, as in releasing a load, the brake is engaged and the motor must overpower the brake drag to rotate the drum. Therefore, it is normal for the winch to operate faster in one direction than the other. The brake is designed for the wire rope to be used in the under-wind position only. **DO NOT OVER-WIND.** Powering against the brake will cause heat to build up in the drum and may transfer heat to the wire rope (Figure 8). **DO NOT POWER OUT FOR MORE THAN 50 FEET (15.2m) OR 2 MINUTES.**



The drum and wire rope may get very hot.

When wire rope is removed from the drum, as in bringing the hook to the load, the freewheel feature of the winch should be used.

2. **DO NOT ALLOW WINCH MOTOR TO OVERHEAT.** Remember, the winch is for intermittent use only. During long or heavy pulls the motor will get hot. For pulling at rated capacity, allow motor to cool after 20 seconds of "On" time. At loads less than 50% of rated capacity, allow to cool after 2 minutes of "On" time. **KEEP THE ENGINE RUNNING TO RECHARGE THE BATTERY during this break.**
3. **USE A PULLEY BLOCK FOR HEAVY LOADS.**To maximize winch and wire rope life, use a pulley block to double line heavier loads (Figure 15).
4. The pull required to start a load moving is often much greater than the pull required to keep it moving. **AVOID FREQUENT STOPS AND STARTS during pull.**
5. **PREVENT KINKS BEFORE THEY OCCUR.**

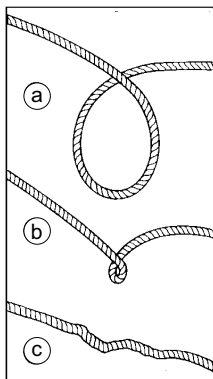

Figure 14

- a. This is the start of a kink. At this time, the wire rope should be straightened.
 - b. The wire rope was pulled and the loop has tightened to a kink. The wire rope is now permanently damaged and must be replaced.
 - c. Kinking causes the wire strands under the greatest tension to break and thus reduces the load capacity of the wire rope. The wire rope must be replaced.
6. **EQUIPPING THE WINCH WITH A ROLLER FAIRLEAD** will substantially reduce wear on the wire rope during angle pulls (Figure 16). The rollers eliminate heavy rub-bing and abrasion to the wire rope.

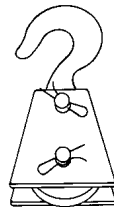

Figure 15

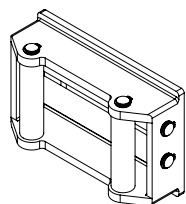

Figure 16

GENERAL SAFETY INFORMATION

Your S series winch is a very powerful machine. Treat it with respect, use it with caution and always follow the safety guidelines.



WARNING *The wire rope may break before the winch stalls. For heavy loads, use a pulley block to reduce the load on the wire rope.*

1. The U4000 and U5000 winch is rated at 4,000 and 5,000 pounds (1814 and 2268 kg) (single line) capacity on the wire rope layer closest to the drum. **DO NOT OVERLOAD. DO NOT ATTEMPT PROLONGED PULLS AT HEAVY LOADS.** Do not maintain power to the winch if the motor stalls. Overloads can damage the winch and/or the wire rope and create unsafe operating conditions. **FOR LOADS OVER 2/3 RATED CAPACITY, WE RECOMMEND THE USE OF THE OPTIONAL PULLEY BLOCK TO DOUBLE LINE THE WIRE ROPE** (Figures 3 & 15). This reduces the load on the winch and the strain on the wire rope by approximately 50%. If attaching back to vehicle, attach to the frame or other load bearing part. The vehicle engine

should be running during winch operation to minimize battery drain and maximize winch power and speed. If considerable winching is performed with the engine off, the battery may be too weak to restart the engine.

2. **AFTER READING AND UNDERSTANDING THIS MANUAL, LEARN TO USE YOUR WINCH.** After installing the winch,

practice using it so you will be familiar with it when the need arises.



3. **DO NOT "move" your vehicle to assist the winch in pulling the load.** The combination of the winch and vehicle pulling together could overload the wire rope and the winch.
4. **KEEP WINCHING AREA CLEAR.** Do not allow people to remain in the area during winching operations. **ALWAYS STAND CLEAR OF WIRE ROPE, HOOK AND WINCH. IN THE UNLIKELY EVENT OF ANY COMPONENT FAILURE, IT IS BEST TO BE OUT OF HARM'S WAY.**

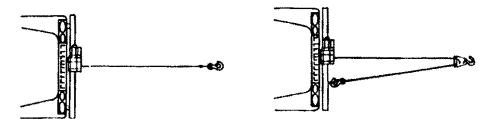

Single Line

Double Line

Figure 3

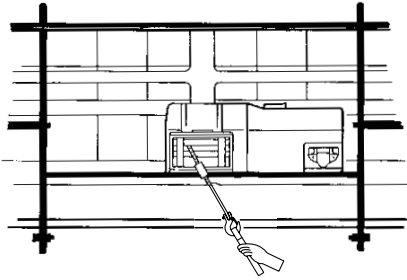

Figure 4

5. INSPECT WIRE ROPE AND EQUIPMENT FREQUENTLY. A FRAYED WIRE ROPE WITH BROKEN STRANDS SHOULD BE REPLACED IMMEDIATELY. Always replace wire rope with the manufacturer's identical replacement part (see Replacement Parts List). Replacement Parts List). installation to ensure that all bolts are tight.

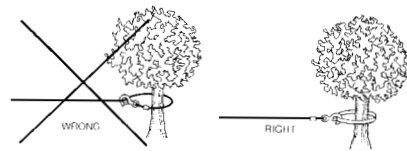

Figure 5

6. USE HEAVY LEATHER GLOVES when handling wire rope. DO NOT LET WIRE ROPE SLIDE THROUGH YOUR HANDS EVEN WHEN WEARING GLOVES.

7. NEVER WINCH WITH LESS THAN 5 TURNS of wire rope AROUND THE WINCH DRUM since the wire rope end fastener will NOT withstand a load. ALWAYS USE THE HANDSAVER when guiding the wire rope in or out (Figure 4).

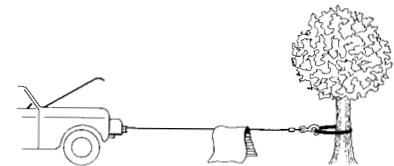

Figure 6

8. KEEP CLEAR OF WINCH, TAUT WIRE ROPE AND HOOK WHEN OPERATING WINCH. Never put your finger through the hook. If your finger should become trapped in the hook, you could lose your finger. **Never guide a wire rope onto the drum with your hand.**

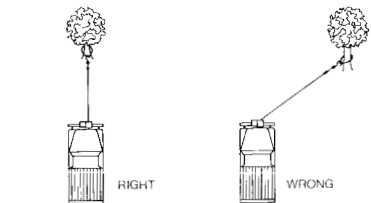

Figure 7



CAUTION The switch assembly must be kept free of dirt and moisture to ensure safe operation.

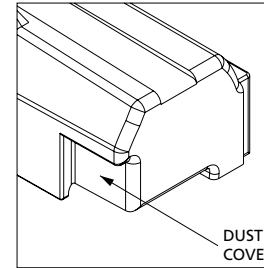

Figure 12

PULLING OUT THE WIRE ROPE

The wire rope has been installed on your winch under minimal load at the factory. The wire rope must be respooled onto the drum under load so that the outer layers will not draw down into the inner ones, thereby damaging the wire rope. Lift the clutch lever to the "Free" position as shown in Figure 12. If there is a load on the wire rope, the clutch lever may not turn easily. DO NOT FORCE THE CLUTCH LEVER.

Release tension on the wire rope by jogging out some of the wire rope. Releasing the clutch and pull out the wire rope and secure to anchor or load. Check that there are at least five (5) turns of wire rope left on the drum. Re-engage the drum by returning the clutch lever to the "Engaged" position (Figure 13).



CAUTION Lever must be in the "Engaged" position and locked before winching.

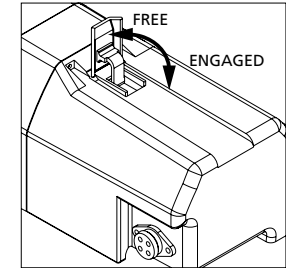

Figure 13

TIPS FOR EXTENDING THE LIFE OF YOUR WINCH

1. KEEP THE WIRE ROPE TIGHTLY WOUND ON THE DRUM. Do not allow the wire rope to become loosely wound. A loosely-wound spool allows a wire rope under load to work its way down into the layers of wire rope on the drum. When this happens, the wire rope may become wedged within the body of the windings damaging the wire rope. To prevent this problem, keep the wire rope tightly and evenly wound on the drum at all times. A good practice is to rewind the wire rope under tension after each use. One way to do this is to attach the hook to a stationary object at the top of a gradual incline and winch your vehicle up the incline.

Attach the circuit breaker assembly to the end of the blue terminated wire. Wrap the circuit breaker assembly with electrical tape to prevent accidental short circuits.

Note: If you choose to locate the winch at a greater distance than the wires provided will permit, it may be necessary to purchase a larger gauge wire to get the best performance from your winch. If the total length of additional wire to be added to the system exceeds 10' (3m), use a larger wire gauge size.

Attach the circuit breaker directly to the battery positive terminal, and reattach the terminal to the battery. If your vehicle is equipped with side pole terminals, it may be necessary to obtain auxiliary side terminal bolts from your local auto parts dealer to make these connections. Connect the remaining wire to the battery negative terminal, and connect the terminal to the battery.

Step (5)

Lift the freespool clutch lever to the "Free" position. Pull several feet of wire rope off the drum.

Return the clutch lever back to the "Engaged" position. Plug in the remote pendant control. Press the switch trigger to the "Rope-Out" position momentarily to check wire rope drum rotation and direction.

If the drum rotates in the wrong direction, recheck your wiring. The Handheld pendant switch activates a solenoid that activates power to the winch motor. One solenoid is for "Rope Out" motor direction and the other is for the "Rope In" motor direction (Figure 11).

CAUTION To prevent unauthorized use of the winch, remove pendant control and store in a clean dry area such as the glove box.

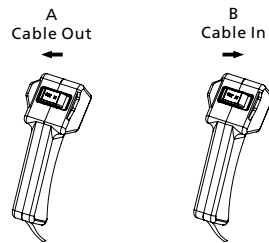

Figure 11

PENDANT OPERATION

The handheld pendant switch activates a solenoid that activates power to the winch motor. To connect the pendant control, remove the cover on the plug receptacle (Figure 12) and insert the plug on the pendant control cord is keyed and will fit into the socket only one way. The switch trigger returns to the "Off" position when released. To change direction, move the toggle in the other direction (Figure 11).

9. NEVER HOOK THE WIRE ROPE BACK ONTO ITSELF because you could damage the wire rope. Use a nylon sling (Figure 5).
10. It is a good idea to lay a heavy blanket or jacket over the wire rope near the hook end when pulling heavy loads (Figure 6). If a wire rope failure should occur, the cloth will act as a damper and help prevent the rope from whipping. Raise the hood of the vehicle for added protection.
11. NEVER USE YOUR WINCH FOR LIFTING OR MOVING PEOPLE. 
12. Your winch is not designed or intended for overhead hoisting operations.
13. AVOID CONTINUOUS PULLS FROM EXTREME ANGLES as this will cause the wire rope to pile up at one end of the drum (Figure 7). This can jam the wire rope in the winch, causing damage to the rope or the winch.
14. NEVER OBSCURE THE WARNING INSTRUCTION LABELS.
15. Always operate winch with an unobstructed view of the winching operation.
16. Equipment such as tackle, hooks, pulley blocks, straps, etc.

should be sized to the winching task and should be periodically inspected for damage that could reduce their strength.

17. NEVER RELEASE FREESPOOL CLUTCH WHEN THERE IS A LOAD ON THE WINCH.
18. STORE THE REMOTE PENDANT ASSEMBLY IN A SAFE PLACE when not in use to prevent use by children or other unauthorized persons.
19. DO NOT OPERATE WINCH WHEN UNDER THE INFLUENCE OF DRUGS, ALCOHOL OR MEDICATION.
20. ALWAYS UNPLUG THE REMOTE PENDANT BEFORE WORKING IN OR AROUND THE FAIRLEAD OR WINCH DRUM (THE DANGER ZONE) so that the winch cannot be turned on accidentally.
21. When moving a load, slowly take up the wire rope slack until it becomes taut. Stop, recheck all winching connections. Be sure the hook is properly seated. If a nylon sling is used, check the attachment to the load.
22. When using your winch to move a load, place the vehicle transmission in neutral, set vehicle parking brake and chock all wheels.

23. DO NOT USE THE WINCH TO HOLD LOADS IN PLACE. Use other means of securing loads such as tie down straps. Novawinch offers a wide variety of tie downs. Contact your local Nova dealer.



24. USE ONLY FACTORY APPROVED SWITCHES, REMOTE CONTROLS AND ACCESSORIES. Use of non-factory approved components may cause injury or property damage and could void your warranty.

25. DO NOT MACHINE OR WELD ANY PART OF THE WINCH. Such alterations may weaken the structural integrity of the winch and could void your warranty.

26. Do not power the winch out for more than 50 feet (15.2m) or longer than 2 minutes.

WARNING The drum and wire rope may get very hot (Figure 8).

27. DO NOT CONNECT WINCH TO EITHER 110V AC HOUSE CURRENT OR 220V MAINS AS WINCH BURNOUT OR FATAL SHOCK MAY OCCUR!

28. Never allow shock loads to be applied to winch or wire rope.

29. Use caution when pulling or lowering a load up and down a ramp or incline. Keep people, pets and property clear of the path of the load.

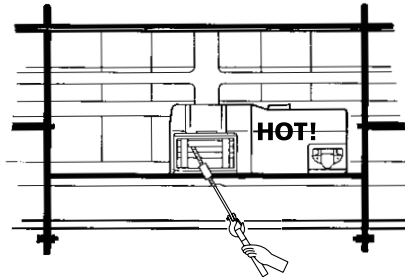

Figure 8

WARNING This winch **MUST** be mounted with the wire rope in the under-wind direction. Improper mounting could damage your winch and void your warranty.

INSTALLATION

MINIMUM ELECTRICAL REQUIREMENTS

For 12 volt winches, a 60 ampere alternator and battery with 440 cold-cranking amperes capacity are the minimum recommended power sources. If the winch is in heavy use, an auxiliary battery and heavy duty alternator are recommended.

Step (1)

Install mounting kit or structural support for winch.

Step (2)

Mount the winch to the mount that you have designed.

Mounting bolts supplied are the correct length for use with up to a 1/4" (6.3mm) thick plate.

WARNING Do not substitute any strength grade weaker than grade 5. When attaching wires to the motor terminals and solenoid (relay), hold the inner nut when tightening the outer nut. Do not allow the motor terminals to rotate for it may cause internal wire breakage or part misalignment. Be especially careful in preventing the solenoid (relay) terminals from rotating. Any rotation can damage the solenoid (Figure 9).

Step (3)

Disconnect the vehicle battery leads.

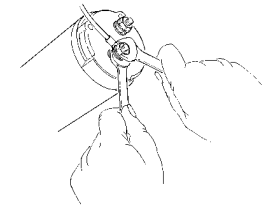

Figure 9

DANGER Automobile batteries contain gasses which are flammable and explosive. Wear eye protection during installation and remove all metal jewelry. Do not lean over battery while making connections.

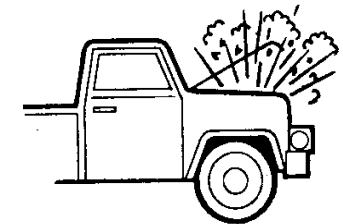

Figure 10

Step (4)

Route the two (2) wires through the vehicle grille to the battery. To ensure against insulation abrasion and/or cutting, apply several layers of electrical tape where wiring may come in contact with sharp metal parts of the vehicle.