



ELECTRIC WINCH

FENIX 25

FENIX 35

FENIX 45

PLEASE READ CAREFULLY BEFORE OPERATE THE WINCH



1689 Xianyuan Road, Jinhua, Zhejiang, China
Tel: 0086-579-82262697
Fax: 0086-579-82262706
<http://www.novawinch.com>
E-mail: info@nowvow.net

TROUBLE SHOOTING

Symptom	Possible Cause	Remedy
Winch will not operate	Cut circuit	Check battery lead
	Weak battery	Recharge or replace battery (at least 650CCA)
	Bad connection of wirings	Reconnect tightly
	Damaged contactor	Replace contactor
	Cut circuit on switch	Replace switch
	Damaged motor or worn brushes	Replace motor or brushes
	Faulty motor wirings	Replace wirings
Motor runs in only one direction	Broken wirings or bad connections	Reconnect or replace wirings
	Damaged or stuck contactor	Replace contactor
	Switch inoperative	Replace switch
	Faulty wiring	Replace wiring
Drum will not free spool	Clutch does not disengage	Engage clutch
	Damaged 1st stage shaft	Replace 1st stage shaft
	Damaged brake	Replace brake
	Damaged motor output shaft	Replace motor output shaft
Brake fails to operate	The gear train is mechanically binding up	Check to insure the winch is mounted on a flat, rigid surface
	Damaged brake	Replace brake
	Damaged gear box	Replace gear box
Brake jam	Proportional mechanism is damaged or worn	Replace
Damaged gear box	Hit by certain exterior force	Replace the damaged components
	Damaged gear train	Replace the damaged components
	Over load operation	Stop the winch operation and reduce a load
Motor runs extremely hot	Long period of operation	Allow to cool
	Damaged motor	Replace or repair motor
	Damaged or inoperative brake	Replace or repair brake

Synthetic Rope	35	Synthetic Rope	1
	36	Hook	1
	37	Hand saver	1
Hawse Fairlead	38	Hawse Fairlead	1
Mounting plate	39	Mounting plate	1
Solenoid	40	Solenoid	1
The thumb switch	41	The thumb switch	1
The triangle plug	42	The triangle plug	1
cables	43	Cable set	1
Remote control	44	Remote control	1
Circuit breaker	45	"Circuit breaker"	1
	46	Circuit breaker cover	1
Hardware set	47	Screws and nuts	1

INTRODUCTION

Thank you for purchasing from Novawinch. It is designed and manufactured to provide years of trouble-free operation. We hope you are pleased with its performance.

SAFETY PRECAUTIONS

The responsibility for safe installation and operation of this winch ultimately rests with you, the operator. Read and understand all safety precautions and operating instructions before installing and operating the winch. Careless winch operation can result in serious injury and/or property damage. Never obscure or remove the warning or instruction labels.

Throughout this manual, you will find notations with the following headings:

⚠ DANGER *Indicates an imminently hazardous situation which, if not avoided, will result in death or serious injury.*

⚠ WARNING *Indicates a potentially hazardous situation which, if not avoided, could result in death or serious injury.*

⚠ CAUTION *Indicates a potentially hazardous situation which, if not avoided, may result in minor or moderate injury. This notation is also used to alert against unsafe practices.*

Note: Indicates additional information in the installation and operation procedures of your winch.

The following symbols on the product and in the Owners manual are used:

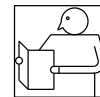

Read Owner's Manual



Always Use Handsaver



Keep clear of winch, wire rope and hook while operating



Never Use winch to lift or move people



Never Use winch to hold loads in place

Correct installation of your winch is a requirement for proper operation.

Please Note: Winch is designed primarily for intermittent applications. This winch is not designed to be used in industrial or hoisting applications and Novawinch does not warrant it to be suitable for such use. Novawinch manufactures a separate line of winches for industrial commercial use.

Congratulations on your choice!

APPLICATION INFORMATION

This winch is designed to move a load at ground level or up an incline. It is neither designed nor intended for hoisting.



This winch is not to be used to lift or move people.

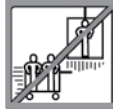

This winch is for intermittent use due to heat build up characteristics of various components.

SAFETY PRECAUTIONS

1. Operator must be alert. Do not operate the winch under the influence of drugs, alcohol or medication.

2. The best way to get acquainted with how the winch operates is to make practice runs before you need it in an emergency situation.

⚠ DANGER *Never connect DC powered winches to AC current. Motor damage or fatal shock may occur.*

⚠ WARNING *Stand clear of wire and load during winching. Keep helpers and spectators at a safe distance. If a wire rope pulls loose or breaks underload, it can lash back with dangerous force.*



3. Beware of the danger zone. The danger zone is the area of the rotating rope drum, the fairlead (if fitted), the rope, the hook, and motor (see Fig 1.) First relieve tension on load then disconnect the control switch before putting hands in or around the danger zone. Disconnect power leads to battery before working in or around drum.

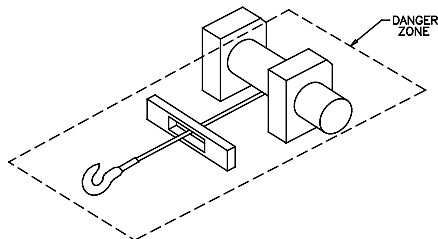

Fig. 1

4. It is recommended that if you are within four feet of the winch, do not hold rope and remote (if equipped) at the same time.

FENIX 4500SR-Parts list

	No.	Description	Qty
Motor Assembly	1	Motor Assembly	1
	2	"Hexagon socket cap screws M5*20"	3
	3	Drum barrel	2
	4	X-ring	2
	5	Coupling I	1
	6	"Rectangular spring"	1
	7	Coupling	1
	8	Spring ϕ 4.8*18*0.8	1
Drum Assembly	9	Hexagonal drive shaft	1
	10	Welded drum	3
	11	Tie bar	1
Gearbox Assembly	12	Gear box cap	1
	13	O ring	1
	14	anti-wear gasket III	1
	15	3rd stage planetary gear assembly	1
	16	2nd stage gear ring	1
	17	2nd stage planetary gear assembly	1
	18	1st stage planetary gear assembly	1
	19	1st stage sun gear	1
	20	Deep groove ball bearing	1
	21	Gear box	1
	22	hexagon socket head cap screws M5*25	3
	23	Cross recessed countersunk head tapping screws ST3.5*12	1
	24	"Clutch cam"	1
	25	Clutch lever	1
	26	O shape sealing ring ϕ 4.5* ϕ 1.5	3
	27	Clutch soulplate	1
	28	Clutch spring	1
	29	Clutch handle	1
	30	Clutch spring	1
	31	ϕ 5/flat washer	1
	32	Cross recess pan head screw M5*10	1
	33	Elastic cylindrical pin	4
34	Square nut	4	

Explosion Drawing with 4500SR

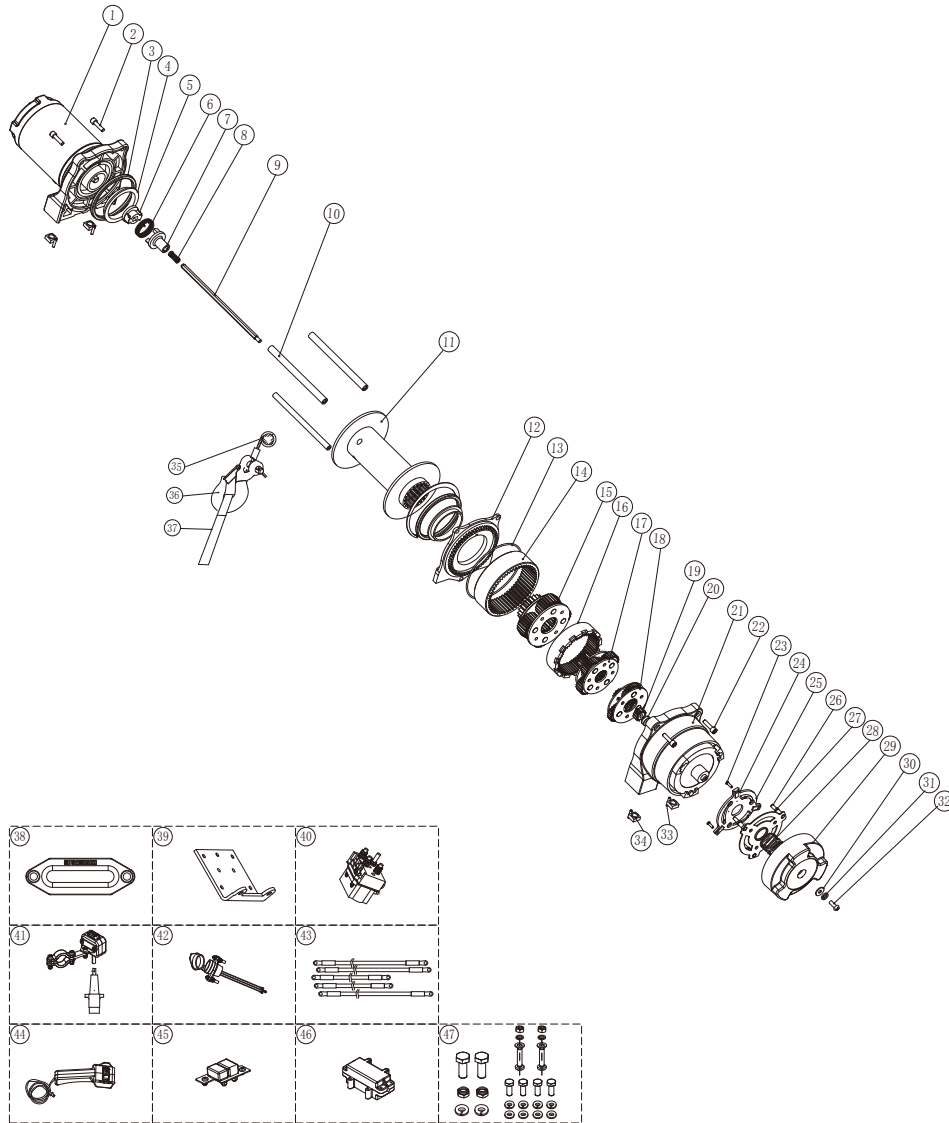

5. USE ONLY FACTORY APPROVED SWITCHES, REMOTE CONTROLS AND ACCESSORIES. Use of non-factory approved components may cause injury or property damage and could void your warranty.

WINCH INSTALLATION

Step (3)
Secure winch (Fig. 2) to mounting kit or structural support using bolts, lock washers and square nuts supplied with winch.

Fig. 2 - Winch mounting

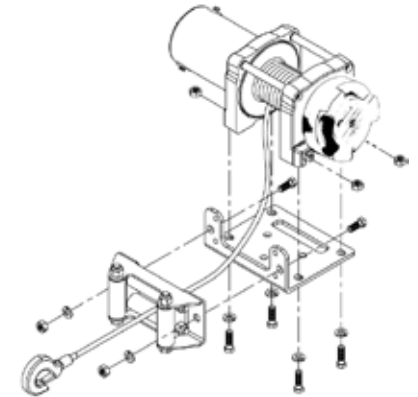

Step (4)
Secure roller fairlead or hawse (Fig. 2) to mounting plate or structural support using hardware supplied

▲ WARNING *Be sure that both the mounting plate and winch hardware have been properly tightened.*

▲ CAUTION *No part of the vehicle (skid plates, wiring, auxillary lights, tires, etc.) should impede the operation of your Novawinch. When mounting, check all vehicle and winch parts for free operation. Be sure that the winch mounting location does not significantly reduce ground clearance.*

SOLENOID MOUNTING

1. The solenoid disconnects your winch from the battery when the vehicle is turned off.
 2. The solenoid should be mounted close to the battery and in a location that is clean and dry as possible.
- Note: The solenoid should not be mounted in an orientation in which the contact posts are in a downward position.

3. Ensure the solenoid location selected provides sufficient clearance form all metal structures,such as frame tubes.

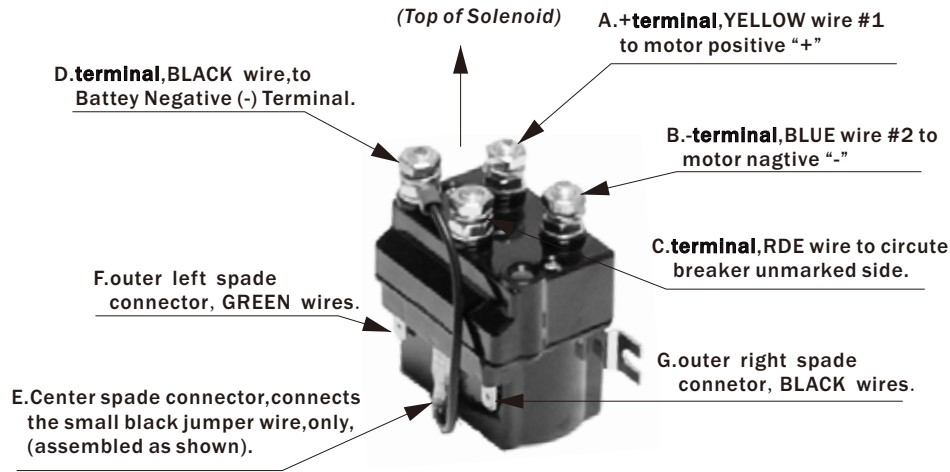

Wire Rope	35	Wire Rope	1
	36	Hook	1
	37	Hand saver	1
Mounting plate	38	Roller fairlead	1
Roller fairlead	39	Mounting plate	1
Solenoid	40	Solenoid	1
The thumb switch	41	The thumb switch	1
The triangle plug	42	The triangle plug	1
cables	43	Cable set	1
Remote control	44	Remote control	1
Circiut breaker	45	"Circiut breaker"	1
	46	Circiut breaker cover	1
Hardware set	47	Screws and nuts	1

TOGGLE SWITCH INSTALLATION

CAUTION When attaching wires to the motor or solenoid terminals, hold the inner nut with a wrench while tightening the outer nut with a second wrench. Do not allow the terminals to rotate in their housings. Rotation may cause internal wire breakage or part misalignment (Fig 4).

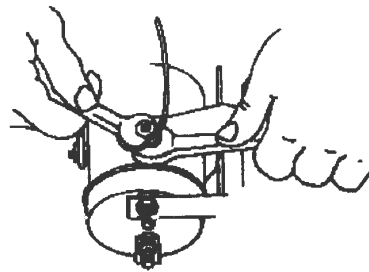

Fig. 4 - Proper Terminal Tightening

Step (1)

Check to ensure that the vehicle ground and positive leads from the battery are disconnected before performing any electrical work.

FENIX 4500WR-Parts list

	No.	Description	Qty
Motor Assembly	1	Motor Assembly	1
	2	"Hexagon socket cap screws M5*20"	3
	3	Drum barrel	2
	4	X-ring	2
	5	Coupling I	1
	6	"Rectangular spring"	1
	7	Coupling	1
	8	Spring ϕ 4.8*18*0.8	1
Drum Assembly	9	Hexagonal drive shaft	1
	10	Welded drum	3
	11	Tie bar	1
Gearbox Assembly	12	Gear box cap	1
	13	O ring	1
	14	anti-wear gasket III	1
	15	3rd stage planetary gear assembly	1
	16	2nd stage gear ring	1
	17	2nd stage planetary gear assembly	1
	18	1st stage planetary gear assembly	1
	19	1st stage sun gear	1
	20	Deep groove ball bearing	1
	21	Gear box	1
	22	hexagon socket head cap screws M5*25	3
	23	Cross recessed countersunk head tapping screws ST3.5*12	1
	24	"Clutch cam"	1
	25	Clutch lever	1
	26	O shape sealing ring ϕ 4.5* ϕ 1.5	3
	27	Clutch soulplate	1
	28	Clutch spring	1
	29	Clutch handle	1
	30	Clutch spring	1
	31	ϕ 5/flat washer	1
	32	Cross recess pan head screw M5*10	1
	33	Elastic cylindrical pin	4
34	Square nut	4	

⚠ DANGER DO NOT ATTEMPT TO INSTALL WIRING WHEN THE BATTERY IS CONNECTED. Automotive batteries contain flammable and explosive gases. Wear eye protection during installation and remove all metal jewelry. Do not lean over battery while making connections.

Step (2)

Route the wiring harness, attaching the harness to hard points on the vehicle with cable ties.

Note: When routing the wires, the appropriate terminals should be located near the battery, switch mounting point, and winch. Your installation requirements will vary depending upon your vehicle and winch. Make sure wires are long enough to reach the battery, switch mounting point and winch.

⚠ WARNING Ensure that the wiring harness does not interfere or come in contact with any hot or moving engine, suspension, steering, braking or exhaust parts.

Step (3)

Using the supplied clamps, bracket and hardware, mount switch in a convenient location. See Fig. 5.

Fig. 5

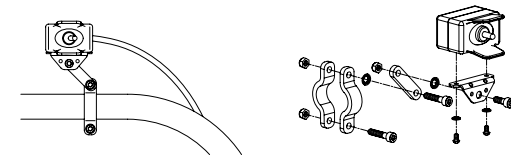

⚠ CAUTION ALWAYS USE THE SWITCH MOUNTING BRACKET, SCREWS, AND LOCK NUTS PROVIDED. Screw lengths are sized for correct penetration into switch box. Excess penetration may result in short circuits that could lead to wire over heating.

Step (4)

It is recommended that the switch be installed on the left handlebar.

Step (5)

Once the switch is mounted, route the jacketed green and black leads back to where the solenoid is mounted. Splice the red lead into wire that energizes with ignition switch on and de-energizes with ignition off.

WIRING INSTALLATION

Step (1)

Connect the YELLOW 6 ga. wire to the #1 "+" positive terminal on the motor and connect the BLUE 6 ga. wire to #2 "-" negative terminal to the motor. (see Fig. 6)

Route the opposite ends of the YELLOW 6 ga. and the BLUE 6 ga. wires back to the solenoid. On the top of the solenoid, connect the YELLOW 6 ga. wire to terminal A "+" positive. Also, on top of the solenoid connect the BLUE 6 ga. wire to terminal B "-" negative. (see Fig. 3)

Step (2)

On the top of the solenoid, connect the RED 6 ga. wire to the terminal C. Route the opposite end of the RED 6 ga. wire to the circuit breaker and connect the RED 6 ga. wire to the unmarked side of the circuit breaker. (see Fig. 6)

Step (3)

On the top of the solenoid, connect the BLACK 6 ga. wire to terminal D. (see Fig. 3)

Step (4)

On the solenoid, check that the short BLACK jumper wire lead, is installed from the solenoid's center flat spade connector E, to the solenoid's terminal D. (see Fig. 3).

Step (5)

Attach the BLACK wire from the rocker switch to the outer right spade, G connector, of the solenoid. Attach the BLACK wire from the optional socket assembly to the same outer right spade connector, G note; the solenoid top side up (see Fig. 6 and 3)

Step (6)

Attach the GREEN wire from the rocker switch to the outer left spade connector G on the solenoid. Attach the GREEN wire from the optional socket assembly to the same outer left spade connector G. note; the solenoid top side up (see Fig. 6 and 3)

Step (7)

Connect the RED WIRE, from the rocker switch and optionally from the socket assembly to your ATV's Ignition Switch key controlled wire. This wire must only have power when the key is in the on position. A fuse protected key controlled wire is preferred. Fuse should be rated for at least 4 amps. Cover-wind the connection with multi-layers of CE approved electrical insulation tape, (see Fig. 6).

Step (8)

Connect the short RED 6 ga. wire to the end of the circuit breaker, marked positive. Connect the other end of this RED wire to the "+" positive battery terminal. (see Fig. 6)

Step (9)

Route the opposite end of the BLACK wire from, solenoid terminal D, and connect to the "-" negative terminal on the battery. (see Fig. 6)

Step (10)

Check that all wiring is clear of sharp edges and pinch points. Check that all wiring is firmly connected to it's proper terminal or spade connector. Secure loose wiring with tie wraps and electrical insulation tape.

Explosion Drawing with 4500WR

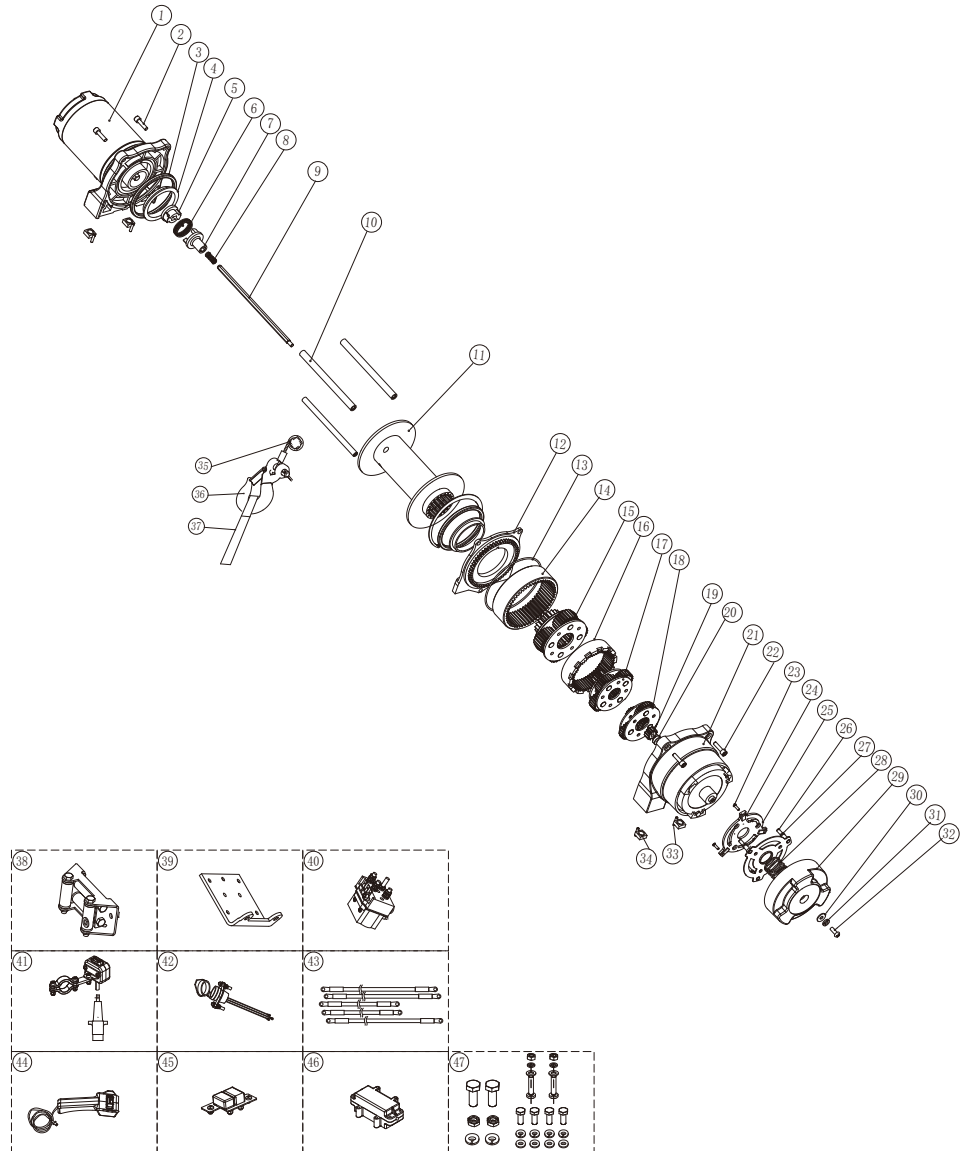

Synthetic Rope	35	Synthetic Rope	1
	36	Hook	1
	37	Hand saver	1
Hawse Fairlead	38	Hawse Fairlead	1
Mounting plate	39	Mounting plate	1
Solenoid	40	Solenoid	1
The thumb switch	41	The thumb switch	1
The triangle plug	42	The triangle plug	1
cables	43	Cable set	1
Remote control	44	Remote control	1
Circuit breaker	45	"Circuit breaker"	1
	46	Circuit breaker cover	1
Hardware set	47	Screws and nuts	1

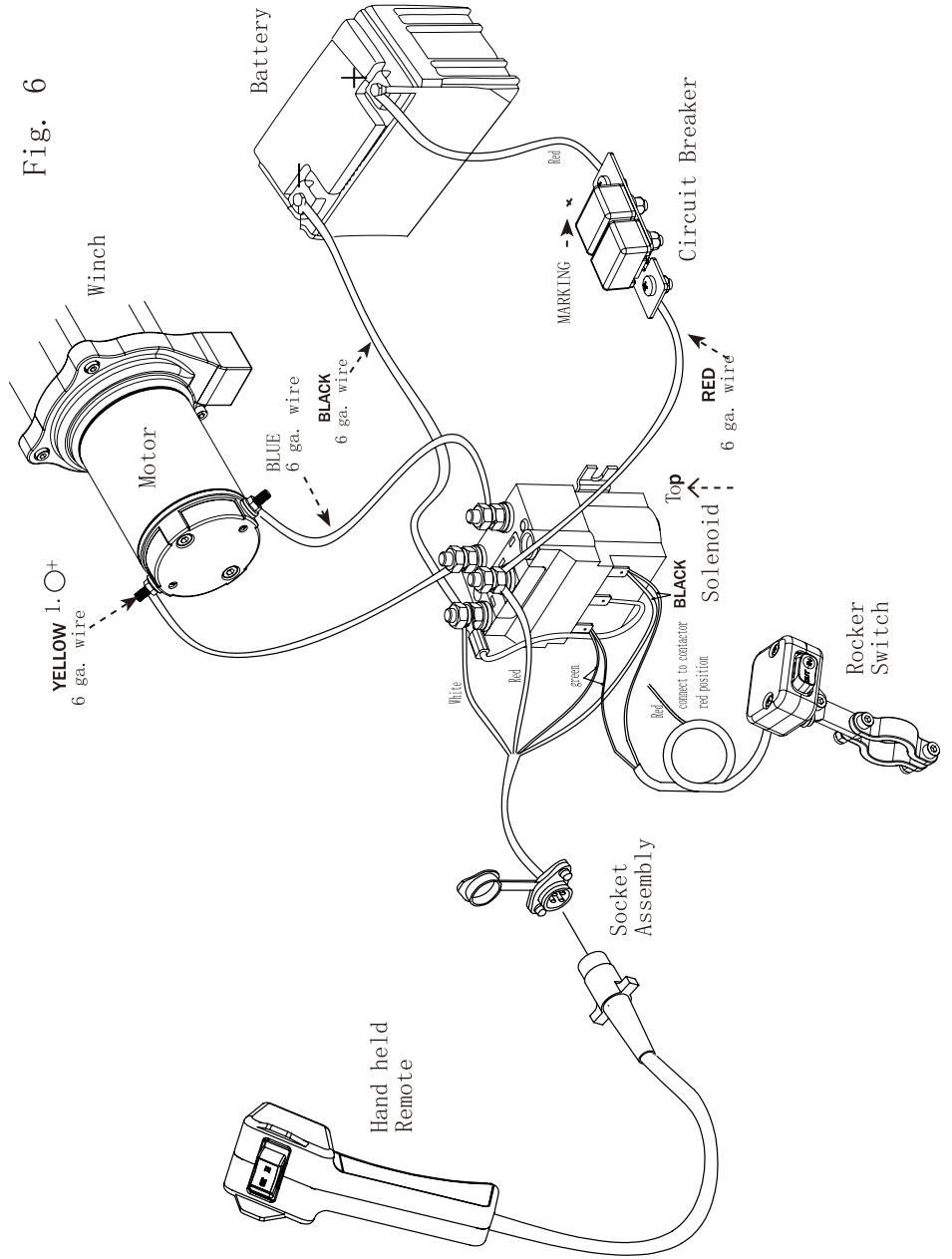



WARNING Before testing winch operation, be sure to reel off approximately two feet of rope.

TEST DRIVE

1. Double check that all wiring is correct and that there are no exposed terminals that can short to the vehicle frame.
2. Turn the ignition key to the ON position. Check winch for

REMOTE SOCKET MOUNTING - optional

1. Determine the mounting location for the remote socket.
2. Drill three holes using the included dimensions as a guide.
3. Once the remote socket is mounted, route the jacketed green and black leads back to where the solenoid is mounted. Splice the red lead to a key controlled electrical wire on the ATV.

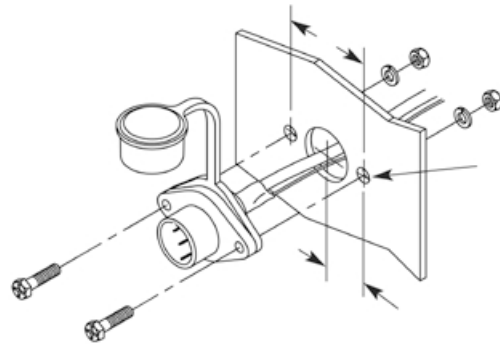

Fig. 7 - Socket Assembly mounts from the outside, inward.

THE COMPLETE KIT

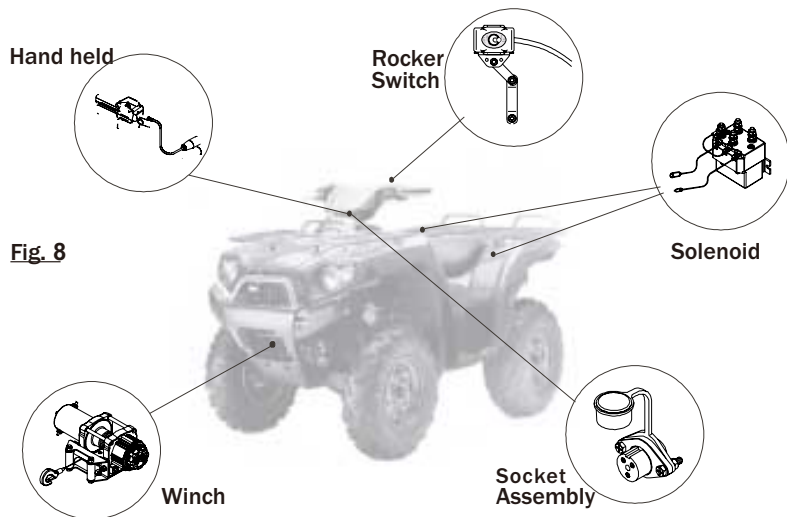
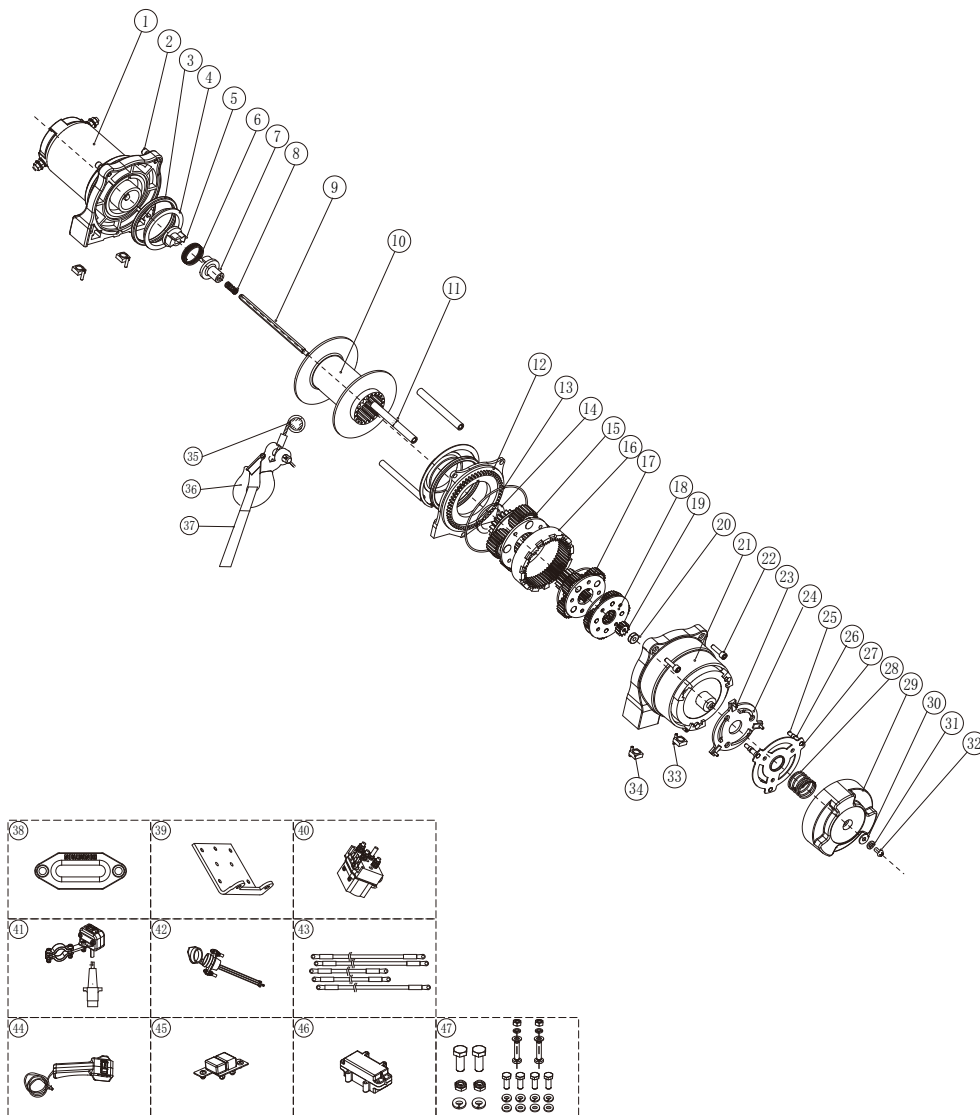

Fig. 8

FENIX 3500SR-Parts list

	No.	Description	Qty
Motor Assembly	1	Motor Assembly	1
	2	"Hexagon socket cap screws M5*20"	3
	3	Drum barrel	2
	4	X-ring	2
	5	Coupling I	1
	6	"Rectangular spring"	1
	7	Coupling	1
	8	Spring ϕ 4.8*18*0.8	1
Drum Assembly	9	Hexagonal drive shaft	1
	10	Welded drum	1
	11	Tie bar	3
Gearbox Assembly	12	Gear box cap	1
	13	O ring	1
	14	anti-wear gasket III	1
	15	3rd stage planetary gear assembly	1
	16	2nd stage gear ring	1
	17	2nd stage planetary gear assembly	1
	18	1st stage planetary gear assembly	1
	19	1st stage sun gear	1
	20	Deep groove ball bearing	1
	21	Gear box	1
	22	hexagon socket head cap screws M5*25	3
	23	Cross recessed countersunk head tapping screws ST3.5*12	1
	24	"Clutch cam"	1
	25	Clutch lever	1
	26	O shape sealing ring ϕ 4.5* ϕ 1.5	3
	27	Clutch soulplate	1
	28	Clutch spring	1
	29	Clutch handle	1
	30	Clutch spring	1
	31	ϕ 5/flat washer	1
	32	Cross recess pan head screw M5*10	1
33	Elastic cylindrical pin	4	
34	Square nut	4	

Explosion Drawing with 3500SR



INSTALLING THE WINCH

⚠ DANGER *Be aware that vehicle batteries contain gases that are flammable and can explode violently. The following precautions should be taken before making battery connection:*

- * Wear eye protection.
- * Remove all jewelry.
- * Follow wiring diagram included in installation instructions.
- * Keep spectators away.

In the event of a battery explosion, acid should be flushed away immediately. Seek medical help as soon as possible.

1. Mount the winch to a firm base. Be sure that your structural support is strong enough to support the rated pulling forces of the winch.
2. While mounting attitude is at your discretion, always remember that your winch is to be operated with the rope in an under wound orientation on the rope drum. Your winch is designed to ROPE IN and ROPE OUT in one direction. DO NOT attempt to reverse the operation of winch.

Fig. 9

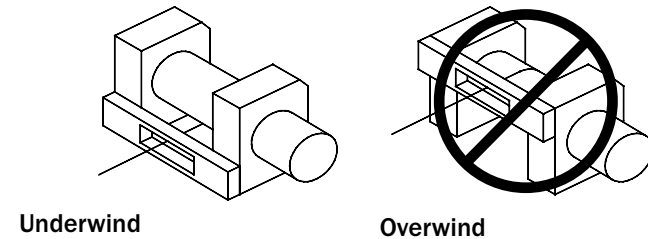

⚠ CAUTION *Do not weld or machine any part of the winch. Machining or welding may weaken the structural integrity of the winch and will void your warranty.*

⚠ CAUTION *Do not mount the winch Inverted (base upward) or put the winch mounting hardware in a direct tension condition. In all installations, the unit must be mounted so that the rope feeds through the hawse or roller fairlead on the front of the winch and does not rub across housings.*

WIRE ROPE

1. The life of the wire rope is directly related to the care it receives. The wire rope on a new winch, and any replacement ropes, should be respooled under a minimum of 100 lb. load before using the winch. Failure to do this will result in wire rope damage. Inspect wire rope before use. Mashed, pinched, frayed or kinked areas severely reduce the load-carrying capability. Replace damaged wire rope.

2. Prevent kinks before they occur.

(a.) This is the start of a kink. At this time, the wire rope should be straightened.

(b.) The wire rope was pulled and the loop has tightened to a kink. The rope is now permanently damaged and should not be used.

(c.) The result of kinking is that each strand pulls a different amount causing the strands under greatest tension to break and reduce load capacity of the wire rope.

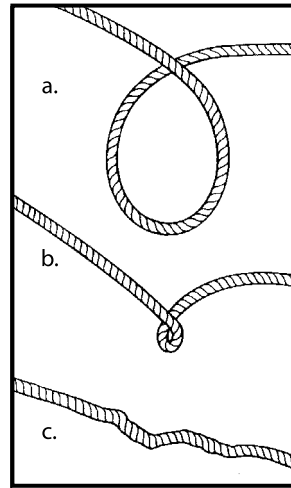

Fig.10

SYNTHETIC ROPE

⚠ DANGER *Sharp edges and abrasion will significantly shorten rope life. Inspect entire length of rope and protective sleeve before each use. Any rope that exhibits cut strands, fused or melted fibers, inconsistent stiffness over the length of the rope, chemical contamination, flat areas or lumps that are not eliminated by flexing the rope, or is otherwise visibly damaged must be replaced immediately. Failure to do so can result in rope failure and personal injury.*

⚠ WARNING

- Do not knot or tie the rope to secure to a load, or to repair a broken rope.
- Do not expose the rope to heat sources or chemicals.
- Do not pull the rope over rough surfaces or sharp edges.
- Do not pull the rope around non-rotating sheaves or rollers.

1. Synthetic Winch Rope Installation:

Pull the rope through hole, (enough line so it reached opposite end of drum). Position inserted line lengthwise down the drum as shown. Using duct tape or similar, secure end of line to drum, taping around drum. Setscrew is not used in this installation. You are ready to wind on the line. (Be sure that line is wound on from underneath drum. Line should come off drum on bottom).

Wire Rope	35	Wire Rope	1
	36	Hook	1
	37	Hand saver	1
Mounting plate	38	Roller fairlead	1
Roller fairlead	39	Mounting plate	1
Solenoid	40	Solenoid	1
The thumb switch	41	The thumb switch	1
The triangle plug	42	The triangle plug	1
cables	43	Cable set	1
Remote control	44	Remote control	1
Circuit breaker	45	"Circuit breaker"	1
	46	Circuit breaker cover	1
Hardware set	47	Screws and nuts	1

FENIX 3500WR-Parts list

	No.	Description	Qty
Motor Assembly	1	Motor Assembly	1
	2	"Hexagon socket cap screws M5*20"	3
	3	Drum barrel	2
	4	X-ring	2
	5	Coupling I	1
	6	"Rectangular spring"	1
	7	Coupling	1
	8	Spring $\phi 4.8*18*0.8$	1
Drum Assembly	9	Hexagonal drive shaft	1
	10	Welded drum	1
	11	Tie bar	3
Gearbox Assembly	12	Gear box cap	1
	13	O ring	1
	14	anti-wear gasket III	1
	15	3rd stage planetary gear assembly	1
	16	2nd stage gear ring	1
	17	2nd stage planetary gear assembly	1
	18	1st stage planetary gear assembly	1
	19	1st stage sun gear	1
	20	Deep groove ball bearing	1
	21	Gear box	1
	22	hexagon socket head cap screws M5*25	3
	23	Cross recessed countersunk head tapping screws ST3.5*12	1
	24	"Clutch cam"	1
	25	Clutch lever	1
	26	O shape sealing ring $\phi 4.5*\phi 1.5$	3
	27	Clutch soulplate	1
28	Clutch spring	1	
29	Clutch handle	1	
30	Clutch spring	1	
31	$\phi 5$ /flat washer	1	
32	Cross recess pan head screw M5*10	1	
33	Elastic cylindrical pin	4	
34	Square nut	4	



Fig.11

2. Synthetic Winch Rope Inspection:

When rope is new, it has a smooth finish (a.). When the rope is first used, the outer filaments of the rope will roughen and give the rope a slightly, "fuzzy" appearance (b.). This condition of the outer filaments creates a rougher rope surface and actually helps to protect the fibers underneath. Rope must be replaced when approximately 25% of the visible outer fibers exhibit abrasion (c.).



Examine both inner and outer fibers. Open the strands of the rope by compressing the rope length-wise (e.) and look for powdered fiber and abrasion - this is a sign of internal wear of the rope. Estimate internal fiber loss to include in your determination of overall abrasion fiber loss of the rope.

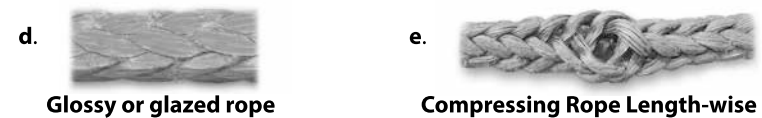

Glossy or glazed areas in the rope (d.) can be the result of 2 different conditions. The most common form of glossing or glazing is caused by compression, which can occur when the rope is wound on the winch drum, or through a pulley block. Compressing the rope length-wise (e.) will generally make the rope more pliable and begin to resemble normal rope. If the glazed section remains hardened, this can be a sign of heat damage, and the rope must be replaced.

Tips for prolonging the life of your synthetic rope:

It is your responsibility to exercise proper care to prolong the life of your synthetic winch rope.

- 1.) **Minimize rope abrasion.** Use the movable abrasion sleeve whenever the rope comes in contact with rocks or other objects. Slide the sleeve up and down the rope as required. Abrasion will reduce rope life.
- 2.) **Keep the rope clean.** Allowing dirt and debris to enter the rope will lead to abrasion of the rope.
- 3.) **Avoid sharp bends.** A sharp bend in the rope decreases its strength substantially under load and may cause rope damage or failure.

3. When it is necessary to respool the rope under no load after use, hold the remote switch lead in one hand and the rope in the other. Start from as far from the vehicle as the remote switch will allow, activate the switch, walk in several feet of rope and release switch. Repeat the process. Always release the switch before your hand comes within four feet from the fairlead (the physical opening through which the rope passes).

4. Be sure the rope is distributed evenly and tightly on the drum. A loosely wound drum allows the rope to work its way down into the layers of rope on the drum and become wedged.

5. It is not advisable to grease or oil the wire rope due to dirt contamination that will reduce the wire rope life.

PREPARING THE WINCH

⚠ DANGER

Wear heavy leather gloves when handling rope. Do not let the rope slip through your hands, even with gloves on. When handling the hook, always use handsaver. Never put your fingers into the hook. (Fig.12) Placing finger(s) In hook could result in injury.

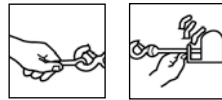

Fig. 12

WRONG

1. When anchoring the pulling vehicle, set the parking brake and block or chock the wheels. Keep the vehicle's foot brake depressed and place the automatic or manual transmission in neutral.

⚠ WARNING

Inspect switch and wiring for cracks, pinched spots, frayed, or loose connections. A damaged, shorted lead could cause the winch to run as soon as it is plugged in.

2. When using the remote switch inside a vehicle, always pass it through a window to avoid pinching the wire in the door.

Explosion Drawing with 3500WR

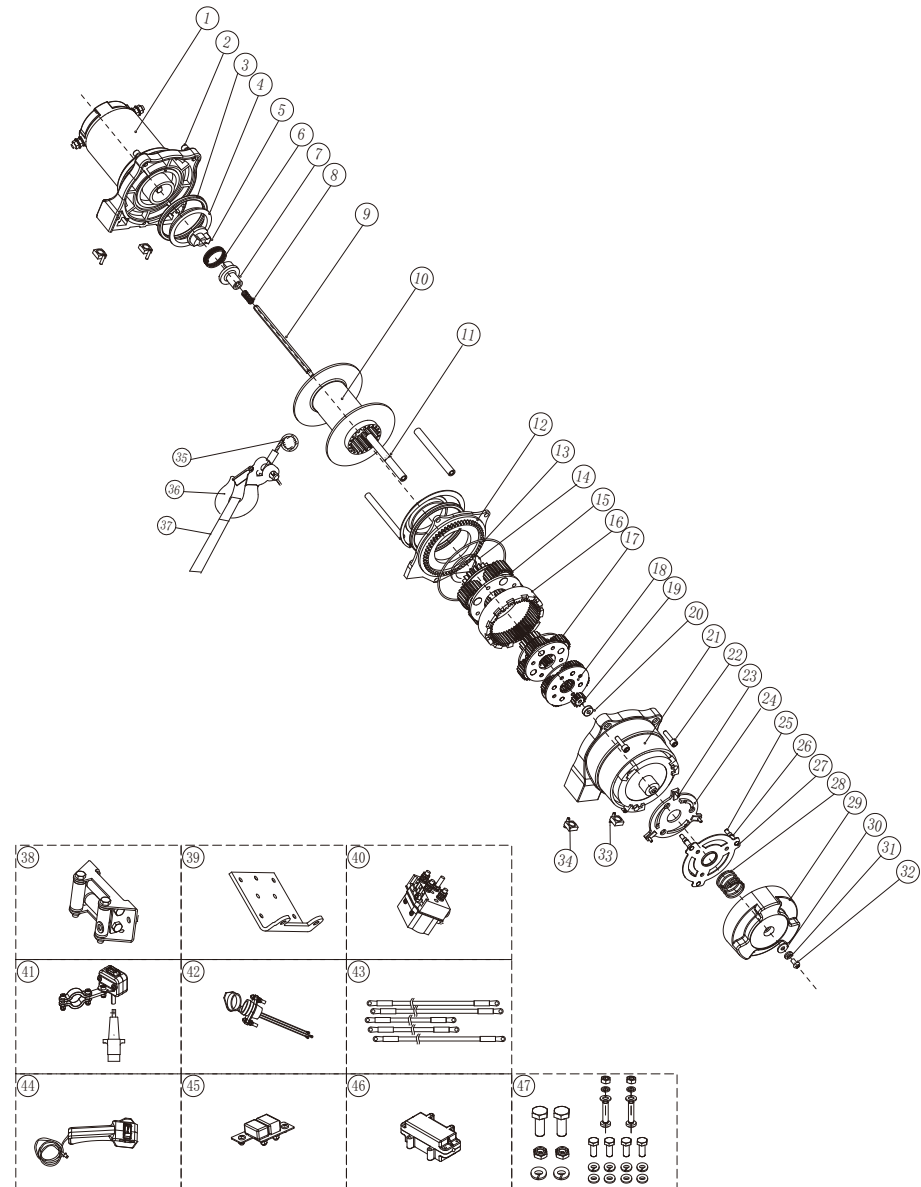

Synthetic Rope	35	Synthetic Rope	1
	36	Hook	1
	37	Hand saver	1
Hawse Fairlead	38	Hawse Fairlead	1
Mounting plate	39	Mounting plate	1
Solenoid	40	Solenoid	1
The thumb switch	41	The thumb switch	1
The triangle plug	42	The triangle plug	1
cables	43	Cable set	1
Remote control	44	Remote control	1
Circuit breaker	45	"Circuit breaker"	1
	46	Circuit breaker cover	1
Hardware set	47	Screws and nuts	1

WINCHING

⚠ DANGER *Never touch the rope or hook while they are in tension or under load. Even at rest, the winch may have the rope in tension. Never guide a rope under tension onto the drum with your hands (see Fig .13).*

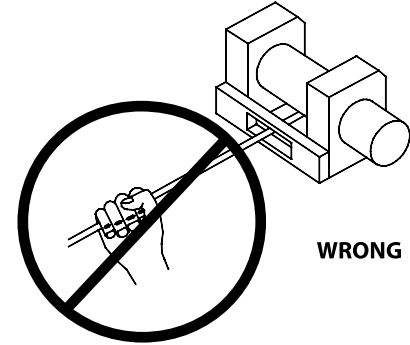

Fig.13

1. Winch with at least five wraps of wire rope or at least eight wraps of synthetic rope around the winch drum. With fewer wraps the rope could pull loose from the drum under load.

2. When pulling a load, place a blanket, jacket or tarpaulin over the wire rope near the hook end (see Fig.14). This will slow the snap back of a broken wire rope and help to prevent serious injury. Raise hood to protect windshield.

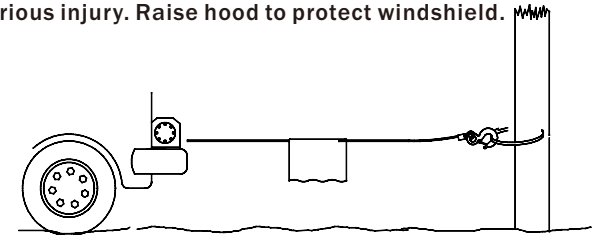
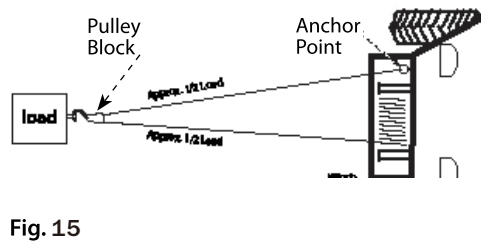
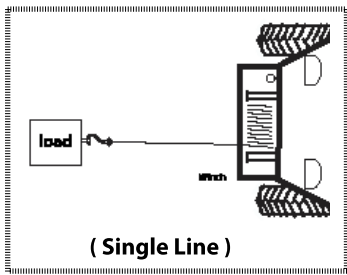

Fig.14

⚠ WARNING *Note the winch's rated capacity and do not exceed it.*

3. Double line with a pulley block (see Fig.15) to reduce the load on the winch, rope and battery. Double lining will also reduce winch line speed. Be sure all equipment used meets the winch's maximum line pull rating. When double-lining, pulley blocks should be rated to a minimum of two times the winch's line pull rating.



4. If you install a tow hook for double lining, it should be attached to the vehicle frame.

5. Equipping the winch with a fairlead will reduce wear on the rope during angle pulls (see Fig.16).The rollers reduce rubbing and abrasion to the rope.

Fig.16

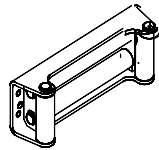

Roller Fairlead

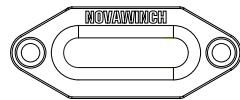

Hawse Fairlead

6. Pull as straight as possible to reduce the buildup of rope on one end of the drum.

7. The vehicle's engine should be running during winching operation. If considerable winching is performed with the engine off, the battery may be too weak to restart the engine.

CAUTION Use a pulley block to avoid winching at sharp angles. Uneven layering will cause serious damage to the winch and rope. It can be corrected by securing load, spooling out the rope and repositioning it to the opposite end of the drum.

DANGER Do not disengage clutch under load. If your winch is equipped with a free spool clutch, be certain that there is no tension on the rope when you disengage the clutch. Before winching a load, be sure the clutch is fully engaged.

CAUTION Use the winch to move the load. Do not attempt to assist the winch by moving the vehicle. The combination of the winch and vehicle pulling could overload the rope and the load could break the winch.

FENIX 2500SR-Parts list

	No.	Description	Qty
Motor Assembly	1	Motor Assembly	1
	2	"Hexagon socket cap screws M5*20"	3
	3	Drum barrel	2
	4	X-ring	2
	5	Coupling I	1
	6	"Rectangular spring"	1
	7	Coupling	1
	8	Spring ϕ 4.8*18*0.8	1
Drum Assembly	9	Hexagonal drive shaft	1
	10	Welded drum	1
	11	Tie bar	3
Gearbox Assembly	12	Gear box cap	1
	13	O ring	1
	14	anti-wear gasket III	1
	15	3rd stage planetary gear assembly	1
	16	2nd stage gear ring	1
	17	2nd stage planetary gear assembly	1
	18	1st stage planetary gear assembly	1
	19	1st stage sun gear	1
	20	Deep groove ball bearing	1
	21	Gear box	1
	22	hexagon socket head cap screws M5*25	3
	23	Cross recessed countersunk head tapping screws ST3.5*12	1
	24	"Clutch cam"	1
	25	Clutch lever	1
	26	O shape sealing ring Φ 4.5* Φ 1.5	3
	27	Clutch soulplate	1
	28	Clutch spring	1
	29	Clutch handle	1
	30	Clutch spring	1
	31	ϕ 5/flat washer	1
	32	Cross recess pan head screw M5*10	1
	33	Elastic cylindrical pin	4
34	Square nut	4	

Explosion Drawing with 2500SR

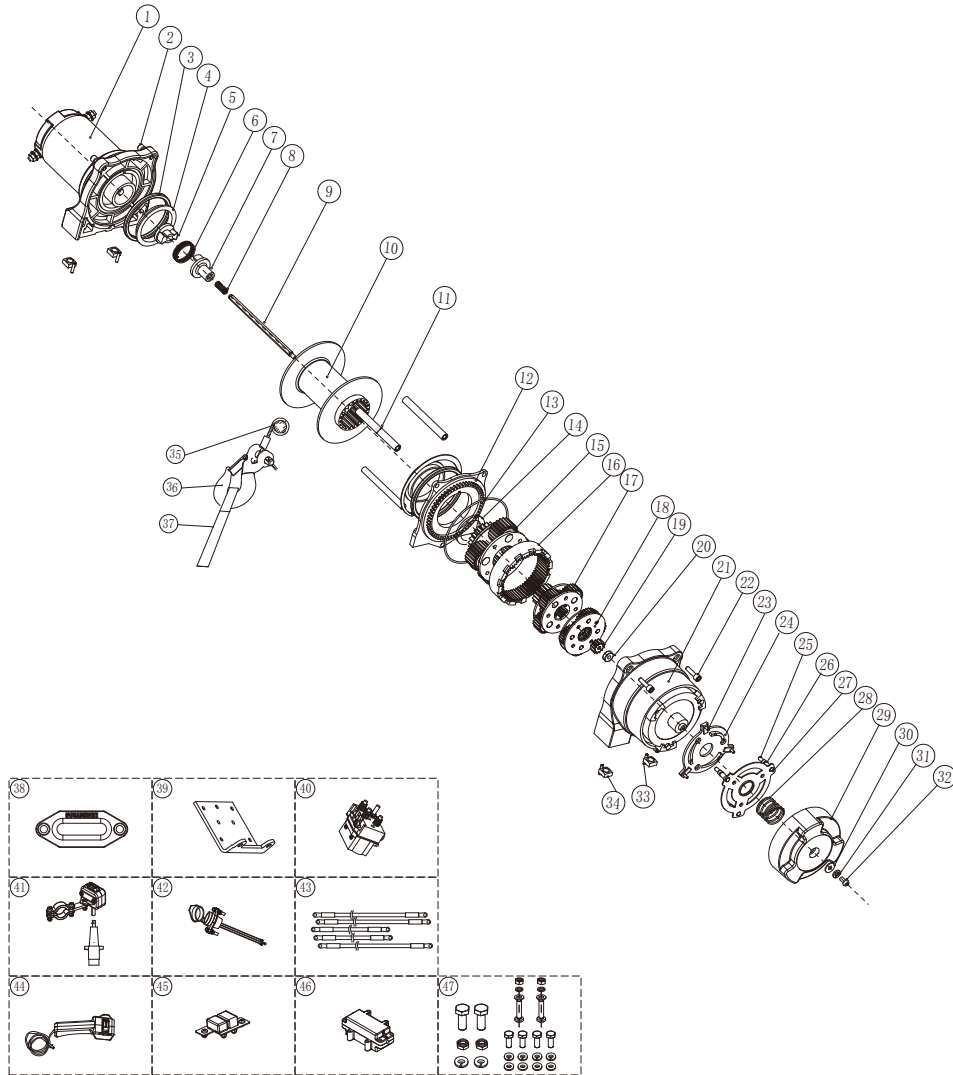

⚠ DANGER *Never rely on the winch to hold a load in place. None of our winches are designed for load-holding applications and may unwind or fall due to shock loading as the load is being transported. The load should be secured by other means, and the winch hook detached from the load.*

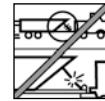

RIGGING

⚠ WARNING *Take your time when rigging and include a reasonable factor for safety. Improper rigging can result in damage to vehicle and equipment. It can also cause injury.*

1. Never handle the rope or rigging while anyone else is at the control switch.

⚠ CAUTION *Use a nylon sling when attaching the rope to an anchor point. Do not attach the hook back on to the rope. Doing so can cause the rope to break.*

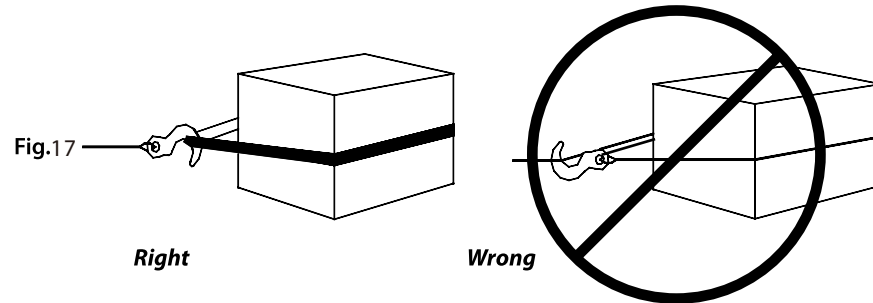

⚠ WARNING *Always use the handsaver (see Fig. 18). Do not hold the hook with your hand. This is important not only when reeling rope in but also when removing rope from the winch under power.*

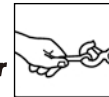
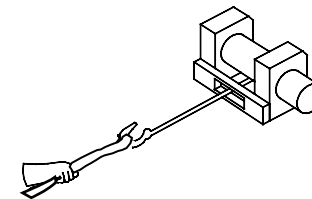

Fig. 18



2.Run the winch intermittently to take up rope slack. when using a pulley block, be sure the rope is running properly in all pulley rollers before applying a load.

⚠ WARNING *Do not re-engage clutch while winch is running.*

⚠ WARNING *Always operate winch with an unobstructed view of the winching operation. Never obscure warning and instruction labels.*

3. Figure (19) Illustrates the most commonly used rigging. A nylon sling is used to protect the tree when it is used as an anchor, and the rope is attached to the sling. The use of a chain or rope is not recommended due to the damage it could cause to the tree.

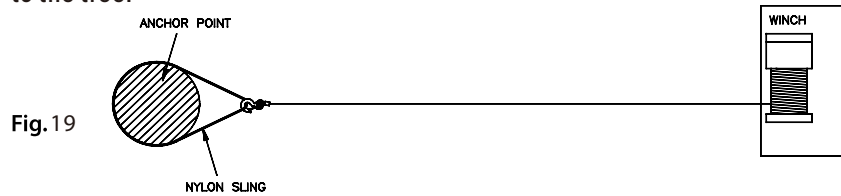

4. Figure (20) Illustrates a method of rigging used to obtain a mechanical advantage. The use of a pulley block will almost double pulling capacity.

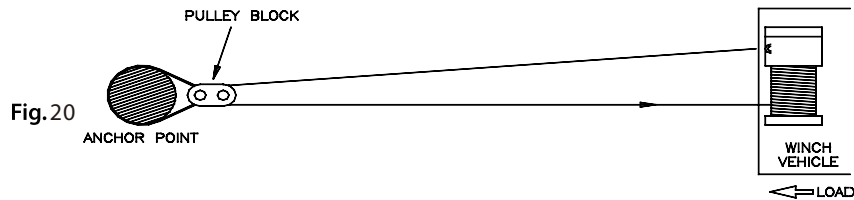

5. Figure (21) Illustrates the use of a pulley block to change the direction of the pull. Mechanical advantage can be obtained by attaching a pulley block to the nylon sling with a shackle and running the rope to the anchor point.

Wire Rope	35	Wire Rope	1
	36	Hook	1
	37	Hand saver	1
Mounting plate	38	Roller fairlead	1
Roller fairlead	39	Mounting plate	1
Solenoid	40	Solenoid	1
The thumb switch	41	The thumb switch	1
The triangle plug	42	The triangle plug	1
cables	43	Cable set	1
Remote control	44	Remote control	1
Circuit breaker	45	"Circuit breaker"	1
	46	Circuit breaker cover	1
Hardware set	47	Screws and nuts	1

FENIX 2500WR-Parts list

	No.	Description	Qty
Motor Assembly	1	Motor Assembly	1
	2	"Hexagon socket cap screws M5*20"	3
	3	Drum barrel	2
	4	X-ring	2
	5	Coupling I	1
	6	"Rectangular spring"	1
	7	Coupling	1
	8	Spring ϕ 4.8*18*0.8	1
Drum Assembly	9	Hexagonal drive shaft	1
	10	Welded drum	1
	11	Tie bar	3
Gearbox Assembly	12	Gear box cap	1
	13	O ring	1
	14	anti-wear gasket III	1
	15	3rd stage planetary gear assembly	1
	16	2nd stage gear ring	1
	17	2nd stage planetary gear assembly	1
	18	1st stage planetary gear assembly	1
	19	1st stage sun gear	1
	20	Deep groove ball bearing	1
	21	Gear box	1
	22	hexagon socket head cap screws M5*25	3
	23	Cross recessed countersunk head tapping screws ST3.5*12	1
	24	"Clutch cam"	1
	25	Clutch lever	1
	26	O shape sealing ring ϕ 4.5* ϕ 1.5	3
	27	Clutch soulplate	1
	28	Clutch spring	1
	29	Clutch handle	1
	30	Clutch spring	1
	31	ϕ 5/flat washer	1
	32	Cross recess pan head screw M5*10	1
	33	Elastic cylindrical pin	4
34	Square nut	4	

Fig. 21

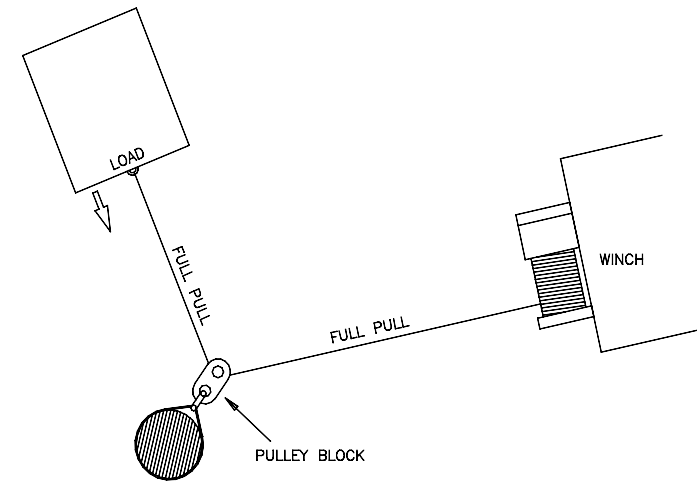

CAUTION *Equipment such as tackle, hooks pulley blocks, straps, etc., should be properly sized and rated and should be inspected periodically for damage that could reduce their strength.*

MOUNTING YOUR WINCH

MOUNTING KITS

NOVAWINCH RECOMMENDS THE USE OF A MOUNT KIT FOR SECURE MOUNTING TO YOUR VEHICLE. ATV Winch mounting kits are available from your Novawinch dealer for nearly all ATV applications. For information on available kits, contact your Novawinch product dealer, or go to www.Novawinch.net for the most current list of kits.

If you choose not to purchase a mounting kit, your Novawinch needs to be attached to a secure and flat mounting location. Note that your winch may not be able to be operated safely without some equipment included in the kit. If you choose not to purchase a mounting kit, contact Novawinch for recommended accessories and the name of a dealer near you.

Detailed mounting instructions for your specific vehicle are provided with each mounting kit. Read and follow directions carefully.

CAUTION *This winch must be mounted with the rope in the under wound direction (Fig. 22) Improper mounting could damage your winch and void your warranty.*

Fig. 22

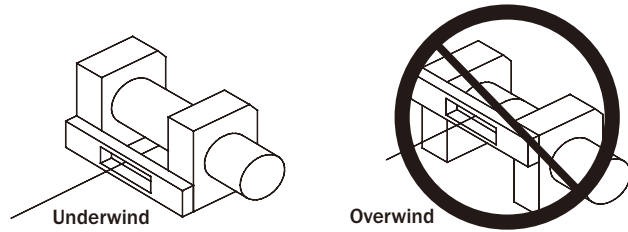

NOTE: It is possible and not uncommon or discouraged to mount your Novawinch in attitudes other than those shown in this installation manual. While mounting attitude is at your discretion, always remember that your winch is to operated with the rope in an under wound orientation on the rope drum (Fig. 22) Your winch is designed to ROPE IN and ROPE OUT in one direction. Do not attempt to reverse the operation of your winch.

CAUTION Do not mount winch inverted, (base upward) or put the winch mounting hardware in direct tension condition. In all installations, the unit must be mounted so that the rope feeds through the hawse or roller fairlead on the front of the winch and does not rub across housings.

For winch capacities, a complete parts list and an exploded diagram of your specific Novawinch, refer to the Technical Data Sheet included in this package.

For instructions on safe winch operation and tips for prolonging the life of your winch, refer to the Safty precautions included in this package.

Note: When installing a winch, your installation may vary slightly from the instructions and diagrams that follow, depending upon your vehicle, winch, mounting kit or structural support.

WARNING Before you start your Novawinch Installation, disconnect the vehicle ground and positive leads from the battery.

MINIMUM ELECTRICAL REQUIREMENTS

Refer to specifications for your winch model in the Technical Data Manual in this age. Be sure to select the appropriate battery or power supply to handle this winch. If the winch is in heavy use, an auxiliary battery and heavy duty alternator are recommended.

INSTALLATION PROCEDURE

Step(1)

Install mounting kit or prepare a flat, secure mounting location for winch to make sure the motor, drum, and gearbox are aligned correctly. Carefully follow the instructions included with the mounting kit.

WARNING Be sure structural support is strong enough to support rated capacity of the winch.

Explosion Drawing with 2500WR

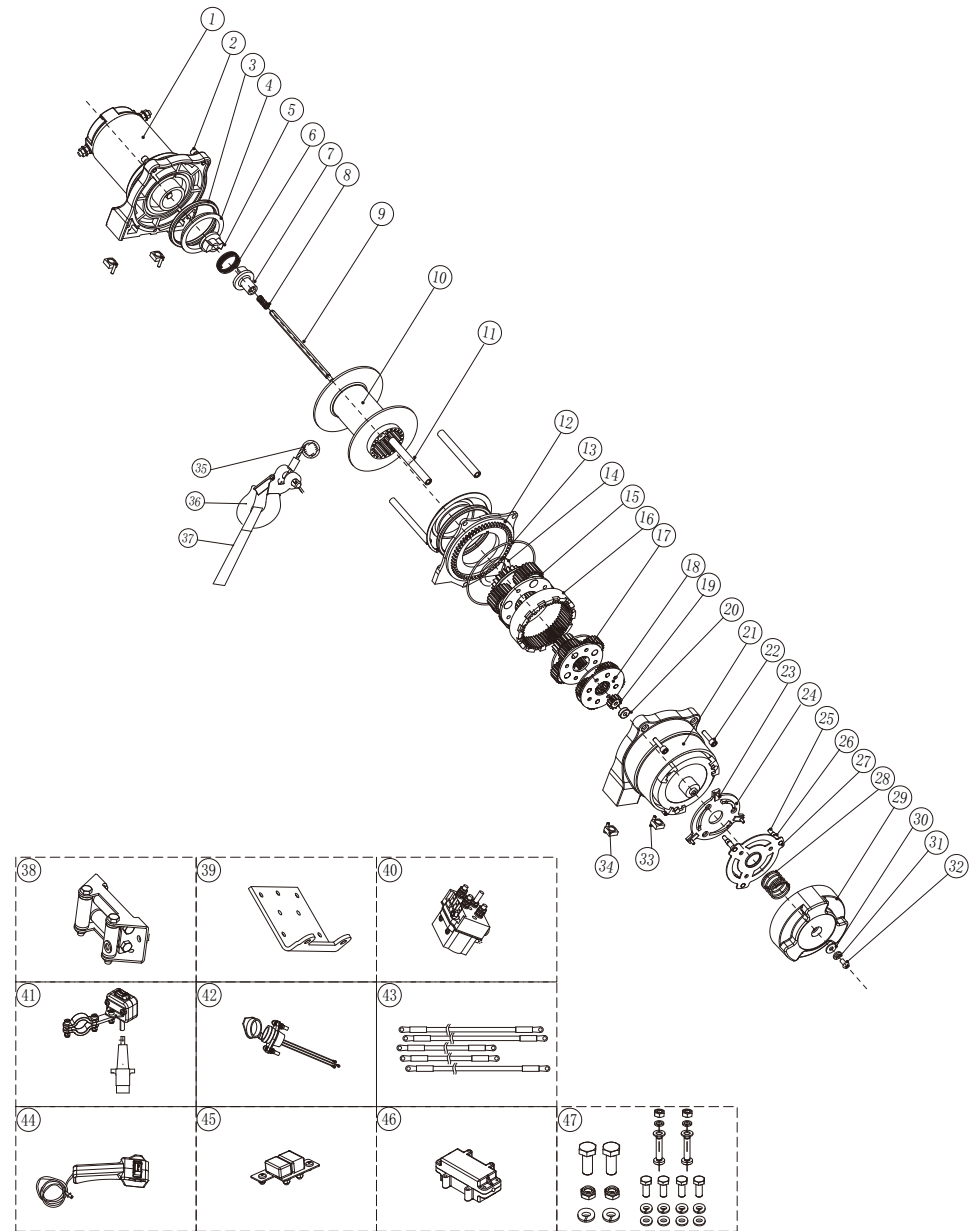

NOTE: If you choose not to use a mounting kit, you will need to drill holes in the structural support. Be sure that your structural support is at least 3/16" (5mm) thick.

⚠ WARNING *If different length bolts, nuts, washers and other hardware are required for your installation, always use hardware that equals or exceeds the strength grade of the supplied hardware. In no circumstances should the end of the mounting bolts touch the inside surface of the casting mount pockets.*

Step(2)
Position the winch over the holes in the mounting kit or structural support.

⚠ WARNING *As you position the winch, make sure that the rope winds in the proper rotation on the drum. Your winch is intended to operate in one direction only. Failure to operate the winch in the proper direction can cause the winch brake (if equipped) to operate improperly, and/or cause the winch to fall.*

⚠ CAUTION *Do not weld or machine any part of the winch. Machining or welding may weaken the structural integrity of the winch and will void your warranty.*

4500lb Specifications	
Rated line pull	4500lbs(2043kgs)
Motor(Series wound)	DC 12V: 3.7hp/2.8kW
Gearing Ratio	191:1
Clutch	Ergonomic control
Dimensions	15.2" L x 4.5" D x 4.8" H 387mm L x 115mm D x 123mm H
Fairlead	4-way roller fairlead or hawse fairlead
Wire Rope	15/64" x 55.7' (φ 6 mmx 17m)
Drum Diameter	2.0" (50mm)
Drum Length	4.9" (122mm)
Drum Length	Waterproof handheld remote,9.85'(3.0m) cord Waterproof Mini-rocker remote,9.85'(3.0m) cord
weight	33 lbs (15kg) with wire rope
Switching Method	Sealed handlebar mounted rocker switch or sealed handheld rocker

Performance			
Load	lb	0	4500
	kg	0	2043
Speed	ft/min	15.0	5.5
	m/min	4.6	1.7
Motor Current Amps		32	230

Technical Data Sheet

2500lb Specifications	
Rated line pull	2500lbs(1135kgs)
Motor(Series wound)	DC 12V:3.0hp/2.3kW
Gearing Ratio	140:1
Clutch	Ergonomic control
Dimensions	13.3" L x 4.5" D x 4.8" H 338mm L x 115mm D x 123mm H
Fairlead	4-way roller fairlead or hawse fairlead
Wire Rope	3/16" x 50' (φ 4.8mm x 15.2m)
Drum Diameter	2.0" (50mm)
Drum Length	3.1" (78mm)
Handheld Control:	Waterproof handheld remote,9.85'(3.0m) cord Waterproof Mini-rocker remote,9.85'(3.0m) cord
weight	26.5 lbs (12kg) with wire rope
Switching Method	Sealed handlebar mounted rocker switch or sealed handheld rocker

Performance			
Load	lb	0	2500
	kg	0	1135
Speed	ft/min	26	10.5
	m/min	7.9	3.2
Motor Current Amps		25	190

3500lb Specifications	
Rated line pull	3500lbs(1589kgs)
Motor(Series wound)	DC 12V: 4.1hp/3.1kW
Gearing Ratio	140:1
Clutch	Ergonomic control
Dimensions	13.5" L x 4.5" D x 4.8" H 343mm L x 115mm D x 123mm H
Fairlead	4-way roller fairlead or hawse fairlead
Wire Rope	7/32" x 50' (φ 5.4mm x 15.2m)
Drum Diameter	2.0" (50mm)
Drum Length	3.1" (78mm)
Drum Length	Waterproof handheld remote,9.85'(3.0m) cord Waterproof Mini-rocker remote,9.85'(3.0m) cord
weight	28.6 lbs (13kg) with wire rope
Switching Method	Sealed handlebar mounted rocker switch or sealed handheld rocker

Performance			
Load	lb	0	3500
	kg	0	1589
Speed	ft/min	24	10.2
	m/min	7.3	3.1
Motor Current Amps		35	260