



Memorandum

Date: February 3, 2021
To: Wency Ng and Theresa Engle, San Mateo County
From: Jennifer Abrams and Travis Baggett, WRECO
Project: Mirada Road Pedestrian Bridge Replacement Project
Subject: Fluvial Geomorphic Assessment

Introduction

This *Memorandum* summarizes the basic fluvial geomorphic assessment of Arroyo de en Medio performed by WRECO for the County of San Mateo Department of Public Works (County) to quantify impacts from the Mirada Road Pedestrian Bridge Replacement Project (Project). The existing conditions and the potential Project impacts are discussed.

Project Description

To serve the Coastal Trail, the County proposes to remove the existing concrete arch bridge and metal pedestrian bridge as well as place a new aluminum pedestrian bridge crossing the Arroyo de en Medio. To protect the bridge, trail, roadway, and utilities, the Project would install shotcrete walls with tieback anchors as well as rock slope protection (RSP) along the bluff face and sections of the north and south banks of the Arroyo de en Medio. The Project will also include relocation of existing utilities supported by the existing bridge. The Project location is shown in Figure 1, and the Project Improvement Plan is shown in Figure 2.

The wall would be approximately 170 feet (ft) in length at the first location to the north of the pedestrian bridge, and 110 ft in length to the south of the pedestrian bridge. The 170-ft wall is within the County's right-of-way and the 110-ft wall is within the City of Half Moon Bay's (City) right-of-way. The typical cross section of the proposed soil nail wall, provided by the County, is included in the attachments. The soil nail wall's concrete is 6 inches thick. At the 170-ft segment of wall, there is an average of 2.5 ft of controlled low strength material (CLSM) behind the wall, for a total thickness of 3 ft.



Figure 1. Project Vicinity Map.

Source: Environmental Systems Research Institute (ESRI), with Notes by WRECO

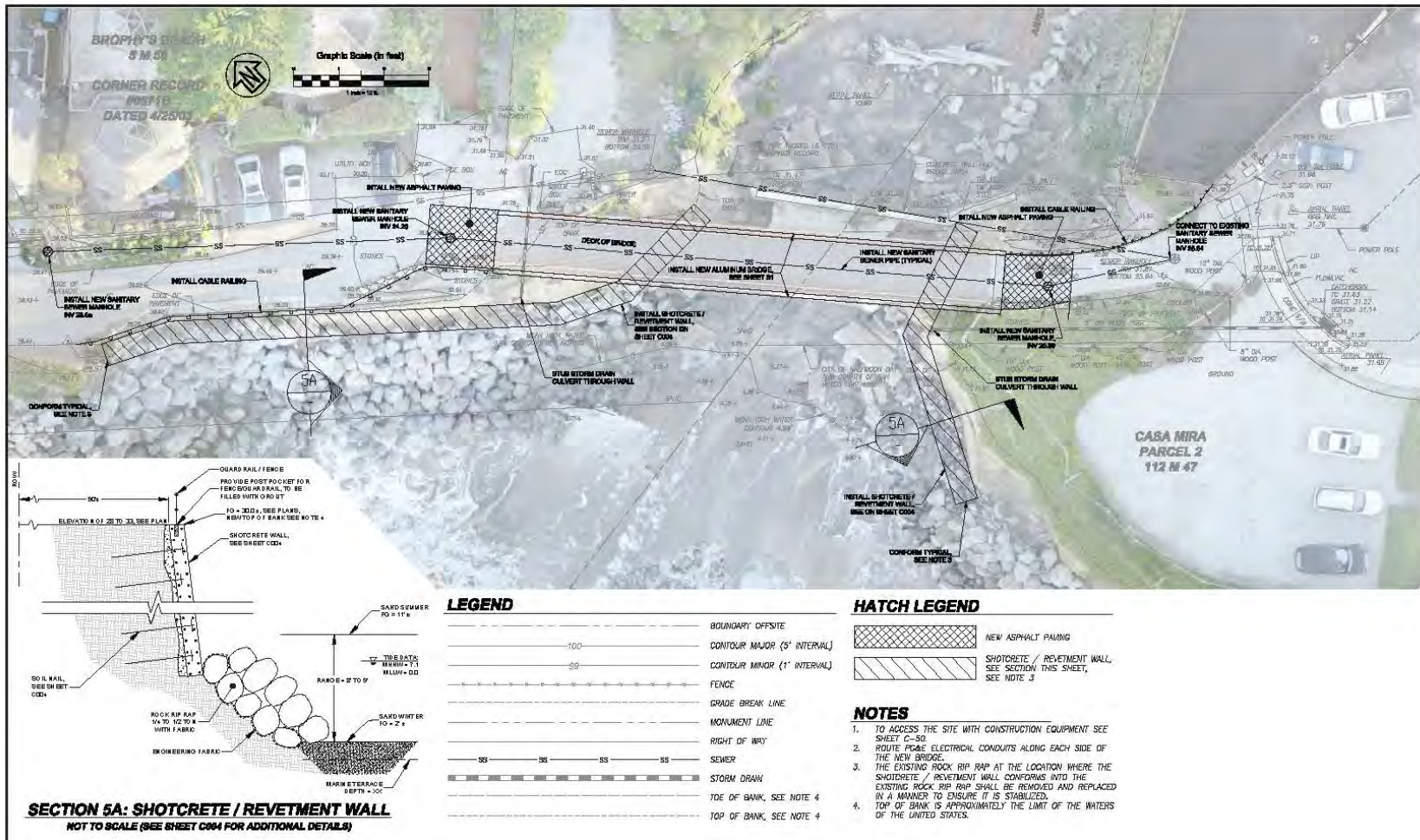

Figure 2. Project Improvements Plan.

Source: San Mateo County Department of Public Works, 2020

This page intentionally left blank



Fluvial Geomorphic Assessment

The Project proposes to make changes to the channel at the mouth of where Arroyo de en Medio discharges into Pacific Ocean. Arroyo de en Medio was assessed for potential impacts due to the proposed Project actions.

This study considers two factors of the fluvial geomorphic system within Arroyo de en Medio, the present stability of the channel, and the potential change in hydraulics. The channel stability is assessed by considering watershed wide features, as well as areas of stability and instability near the Project. Changes in the hydraulics are assessed by considering changes to the hydrology of the watershed, and the hydraulics of the channel due to changes in geometry.

Present Stability

The present stability of Arroyo de en Medio appears to be good. The watershed has undergone a relatively small amount of urbanization, which increases the likelihood that the creek is in a state of natural dynamic stability. However, the soils of the watershed include sand, which is less cohesive than clay, and small enough to be easily transported by streamflow. These soils make the creek bed and banks less resistant to changing in hydraulics.

Watershed Features

The USGS StreamStats application was used to determine watershed parameters of Arroyo de en Medio. The application reports that Arroyo de en Medio has a watershed of 1.1 square miles (see Figure 4) and mean annual precipitation of 31.7 inches. StreamStats also reports data from the National Land Cover Database and shows that as of 2011, the watershed was 14.9% “urban” and 3.2% impervious surfaces. With this relatively small percentage of impervious surfaces, the regional regression equations developed by Gotvald et al. (2012) are a reasonable approximation of the peak flows. Those flows are presented in Table 7.

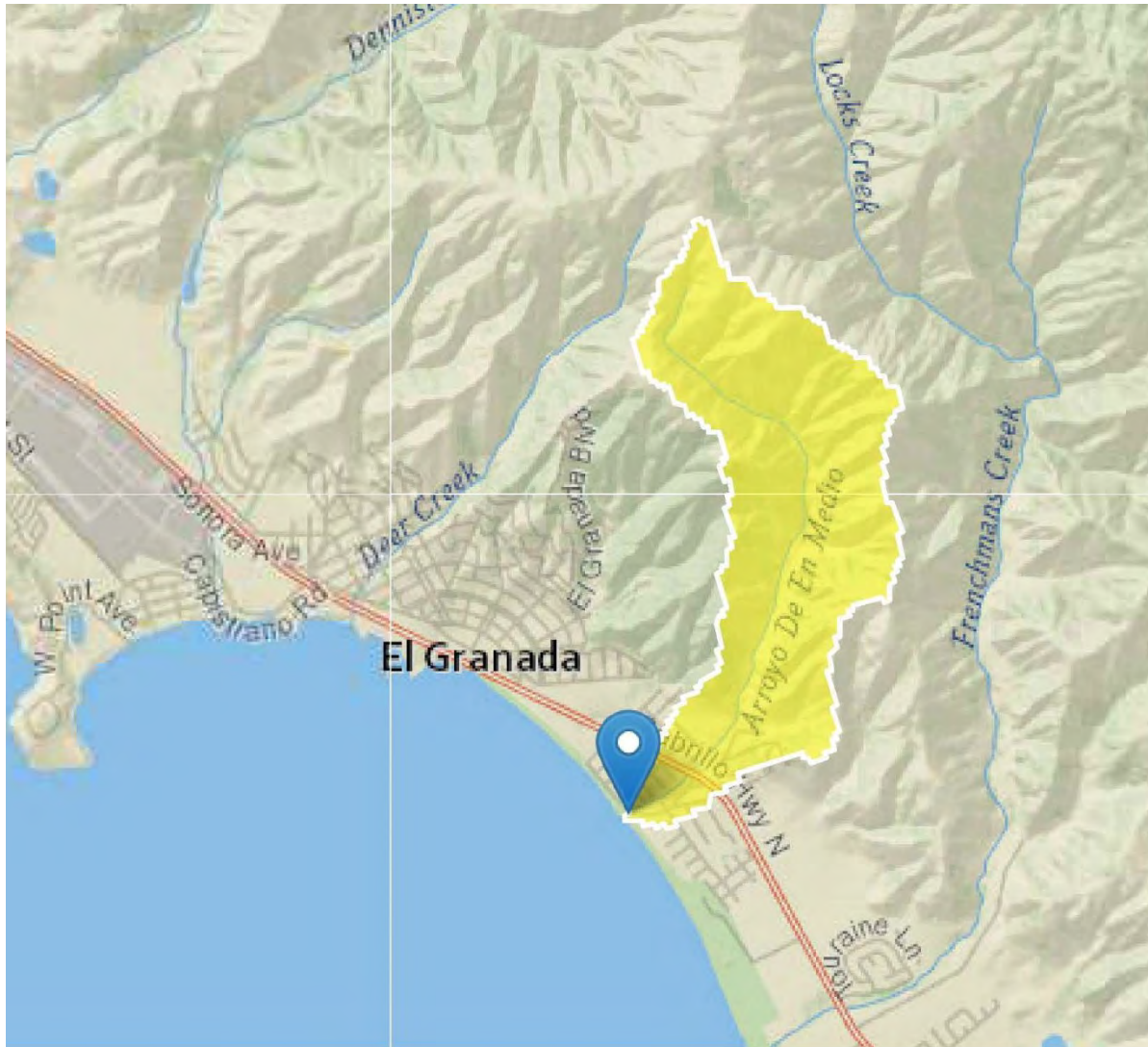

Figure 3. Arroyo de en Medio Watershed

Source: USGS StreamStats

Table 1. Approximate Peak Flows, Regional Regression Equations

Return Interval	Peak Flow (cfs)
2-year	59.3
5-year	127
10-year	178
25-year	248
50-year	302
100-year	360

Soils

The USDA Web Soil Survey application was used to determine the soils present in the watershed of Arroyo de en Medio. The majority of the soils are mapped as “Miramar coarse sandy loam” with varying slopes (see attachment). Miramar coarse sandy loam is described as having a parent material that consists of residuum weathered from quartz-diorite. This is consistent with the coarse-sand sized, angular-shaped bed material found approximately 150-ft upstream of the proposed bridge replacement location. This is in contrast with the fine sand found at the Project location.

Aerial Photos

Aerial photos provide insight into how the form of Arroyo de en Medio has changed over time. Aerial photos from Google, Microsoft, the California Coastal Project, and NETR Online were reviewed. These photos show no notable change in the alignment of the creek from the earliest photos, dated 1946. At that time, the bridge had already been constructed and appears to have been the only road crossing of the creek. The vicinity of the Project was developed into a residential neighborhood, but the development appears to have not encroached into the creek, except for the Highway 1 crossing approximately 1,300 ft upstream of the Project (see Figure 5).

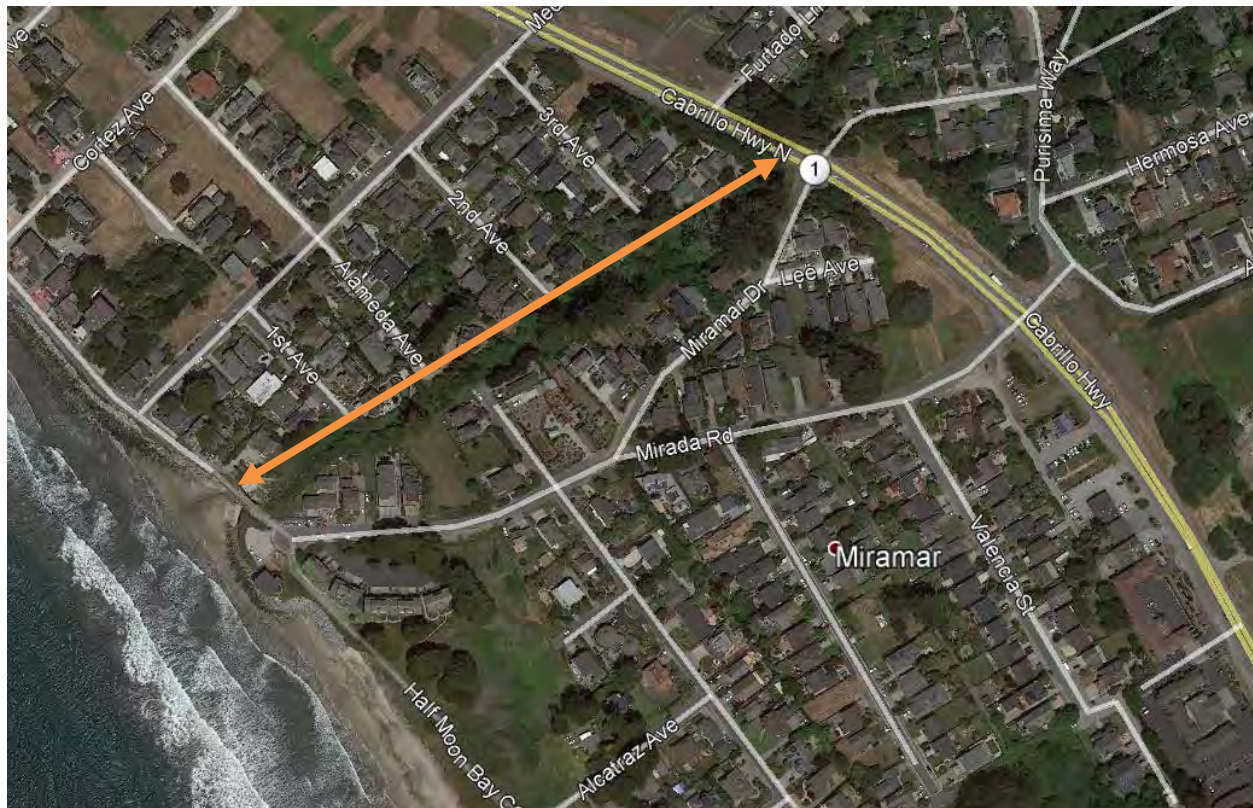

Figure 4. Aerial Photo and Location of Observations

Source: Google

Observations

WRECO staff made observations along the reach of Arroyo de en Medio from Highway 1 to the Project (see Figure 5). Observations at the Project found the bed of Arroyo de en Medio to be fine beach sand (see Photo 1). Large woody debris is in the creek upstream of the Project and appears to have been delivered by the ocean, as opposed to coming down the creek. The bridge arch is a constriction when compared to the open bluffs downstream of the bridge and the wide distance between banks on the upstream of the bridge (see Figure 6). The bed of the creek at the arch is approximately 15 to 20-ft-wide (marked as “A”), while approximately 25 ft upstream. The width of the creek bed is approximately 50-ft-wide (marked as “B”). Approximately 75 ft upstream of the bridge, the creek-bed width narrows again to approximately 20-ft-wide.



Photo 1. Arroyo de en Medio from Project Facing Upstream, December 22, 2020.

This page intentionally left blank

At approximately 100 ft upstream of the Project, the sand bed is covered with many large woody debris and herbaceous growth (see Photo 2 and Photo 3). WRECO staff believe that this location is the highest elevation that wave run-up typically occurs in Arroyo de en Medio. This is based on the observations of the large wood debris that is believed to have been introduced to the system via the ocean, the bed changing from sand to plants, and the dense stand of willow growing immediately upstream of the woody debris. There is a grade break in the form of a near-vertical step of approximately 1-ft in elevation, located at the woody debris. The grade break appears to be stable and WRECO staff believe it is armored by the woody debris, and the bed sediments are held together by the roots of the herbaceous plants. The bankfull dimensions were measured along the cross section marked “C” in Figure 6. The width was measured as 22.5 ft, and the average depth approximately 1.5 ft, totaling a bankfull area of 33.75 square feet. WRECO staff believes this reach of the creek is influenced by coastal processes and its geometry does not represent solely fluvial geomorphic processes.



Photo 2. Approximately 75-foot Upstream of the Project, Facing Upstream, December 22, 2020.



Photo 3. Arroyo de en Medio from Approximately 100-feet Upstream of the Project, Facing Upstream, December 14, 2020.

Approximately 120 ft upstream of the Project, Arroyo de en Medio has a different character (see Photo 4). The cross-sectional shape is similar to the downstream reaches, but with the addition of a well-defined low-flow channel at the thalweg. Between the high banks, the channel is mostly filled with a dense stand of willows that are growing both in the low-flow channel and along the banks. The bed is coarse sand and fine gravel, which appears to be composed of weathered quartz-diorite of the Miramar soils. The many roots of willows and herbaceous plants fill the bed. The bankfull dimensions were measured as 12-ft-wide and approximately 1.7-ft-deep, totaling an area of 20.5 square feet. WRECO staff believes these dimensions to be representative of fluvial geomorphic processes in Arroyo de en Medio.



Photo 4. Approximately 120-feet Upstream of the Project, December 22, 2020.

The furthest observations were made approximately 1,300 ft upstream of the Project on the downstream side of Highway 1. Arroyo de en Medio crosses beneath Highway 1 through a pair of 48-inch culverts. The culverts are perched approximately 2 ft above the bed of the creek, and the middle reach of the culverts are concrete. These culverts represent a limit to upstream migration of vertical erosion of the creek. The creek is more open with an understory of herbaceous plants and well-established eucalyptus trees higher on the banks (see Photo 5). The bed of the creek is composed of coarse sand to fine gravel similar to what was observed further downstream (at 120 ft upstream of the Project). The shape of the creek in cross section is trapezoidal to near the top of banks. Dense vegetation and no visible bankfull indicators made measuring the dimensions of the bankfull area at this location impossible.



Photo 5. Arroyo de en Medio from Highway 1, Facing Downstream, December 22, 2020.



Changes to Hydraulics

WRECO staff considered potential changes to the hydraulics of Arroyo de en Medio by comparing the existing geometry with the proposed geometry. The Project does not include appreciable change to the watershed hydrology of the creek, and WRECO staff do not consider the Project to have any impacts to hydrology.

The assessment of any changes to hydraulics is based on the 65% plans provided by the County of San Mateo (attached). The Project includes three main activities: the soil nail walls, the bridge replacement, and the replacement of RSP. The soil nail wall is primarily on the bluffs facing the ocean, but does include sections of the bluff-face upstream of the bridge. Based on the Bluff Stabilization Plan drawings, the narrowest cross section between the soil nail walls will be approximately 50 ft, which is much wider than the bankfull width measured in the fluvial-dominated reach of Arroyo de en Medio (approximately 21-ft-wide), and wider than the distance between banks at the narrowest cross section within the coastal processes dominated reach (20 ft). WRECO staff does not think the proposed soil nail wall will have an appreciable impact on the fluvial geomorphic processes of the creek.

The Project proposes to replace the existing clear-span bridge with a new clear-span bridge. The General Bridge plans show the existing cement arch is also proposed to be removed. The arch is a constriction when compared to the open face on the ocean side of the arch, and to the wide-set banks on the upstream side of the arch. In a fluvial system, increased width of a channel cross section could alter the fluvial hydraulics. However, WRECO considers this reach of Arroyo de en Medio to be dominated by coastal processes and therefore, WRECO staff does not consider removal of the arch to be an impact to the fluvial geomorphic processes of the creek.

The Project proposes to remove and replace the existing RSP. The Bluff Stabilization Plan drawings show the replaced RSP to be located along the bluffs both on the ocean side of the cement arch, and the landward side of the cement arch. Via personal communication, San Mateo County staff described the RSP work to WRECO staff as follows, “The proposed bluff stabilization will result in the removal of the riprap above the summer dry beach and replacement with a smaller footprint structure that is a combination of rock rip-rap placed below the summer dry beach and a concrete wall located above the summer dry beach.” Therefore, no change in the geometry of bankfull flows of Arroyo de en Medio is proposed, and the RSP replacement would not alter the hydraulics of the creek.

Summary

The reach of Arroyo de en Medio from the Project to approximately 100 ft upstream appears to be dominated by coastal processes. The transition from coastal dominated to fluvial dominated processes (between 100 ft and 120 ft upstream of the Project) is marked by many large woody debris, a change in bed material and vegetation, and a dense stand of willows (see Photo 3). WRECO staff believes this location is geomorphically stable and resistant to disturbances that originate from downstream. The part of the creek considered fluvial-dominated has a narrower bed and narrower distance between banks when compared to the coastal processes-dominated



1243 Alpine Road, Suite 108
Walnut Creek, CA 94596
Phone: 925.941.0017
Fax: 925.941.0018
www.wreco.com

reach near the Project. The creek appears to be relatively stable with no signs of recent erosion noted.

The Project proposes to alter the geometry of the creek with the removal of the cement arch. The existing arch represents a narrowed cross section of the creek; removal of the arch will widen the cross section of the creek at this location. This is within the reach of the creek dominated by coastal processes, and is not expected to impact the fluvial geomorphic processes of the creek. The other proposed Project actions are not expected to impact the fluvial geomorphic processes of the creek.



1243 Alpine Road, Suite 108
Walnut Creek, CA 94596
Phone: 925.941.0017
Fax: 925.941.0018
www.wreco.com

References

California Coastal Records Project. (2021). Online database of aerial photographic survey of the California Coastline. <<https://www.californiacoastline.org/>> Last accessed January 11, 2021.

County of San Mateo Department of Public Works. (June 2016). *Mirada Road Revetment Project Description*.

Google. *Google Earth*. Version 7.1.8.3036. Last accessed: December 28, 2020.

NETROnline, Historic Aerials. (2021). Online Database of Historical Aerials of the United States. < <https://www.historicaerials.com/>> Last accessed: January 11, 2021.

This page intentionally left blank



1243 Alpine Road, Suite 108
Walnut Creek, CA 94596
Phone: 925.941.0017
Fax: 925.941.0018
www.wreco.com

Attachments

- 65% Project Plans



This page intentionally left blank

COUNTY OF SAN MATEO CALIFORNIA

MIRADA ROAD

PEDESTRIAN BRIDGE REPLACEMENT

TOTAL PROJECT LENGTH, APPROXIMATELY 0.05 MILE(S)

TO BE SUPPLEMENTED BY STATE OF CALIFORNIA DEPARTMENT OF TRANSPORTATION STANDARD PLANS DATED MAY 2006 AND ADOPTED BY SAN MATEO COUNTY, NOVEMBER 14, 2006, BY RESOLUTION NO. 68389

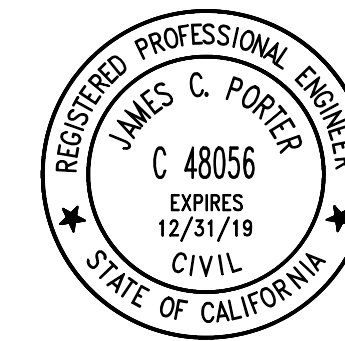

APPROVED: _____
DATE: _____
JAMES C. PORTER, DIRECTOR OF PUBLIC WORKS
R. C. E. # 48056 / EXPIRES 12-31-2019

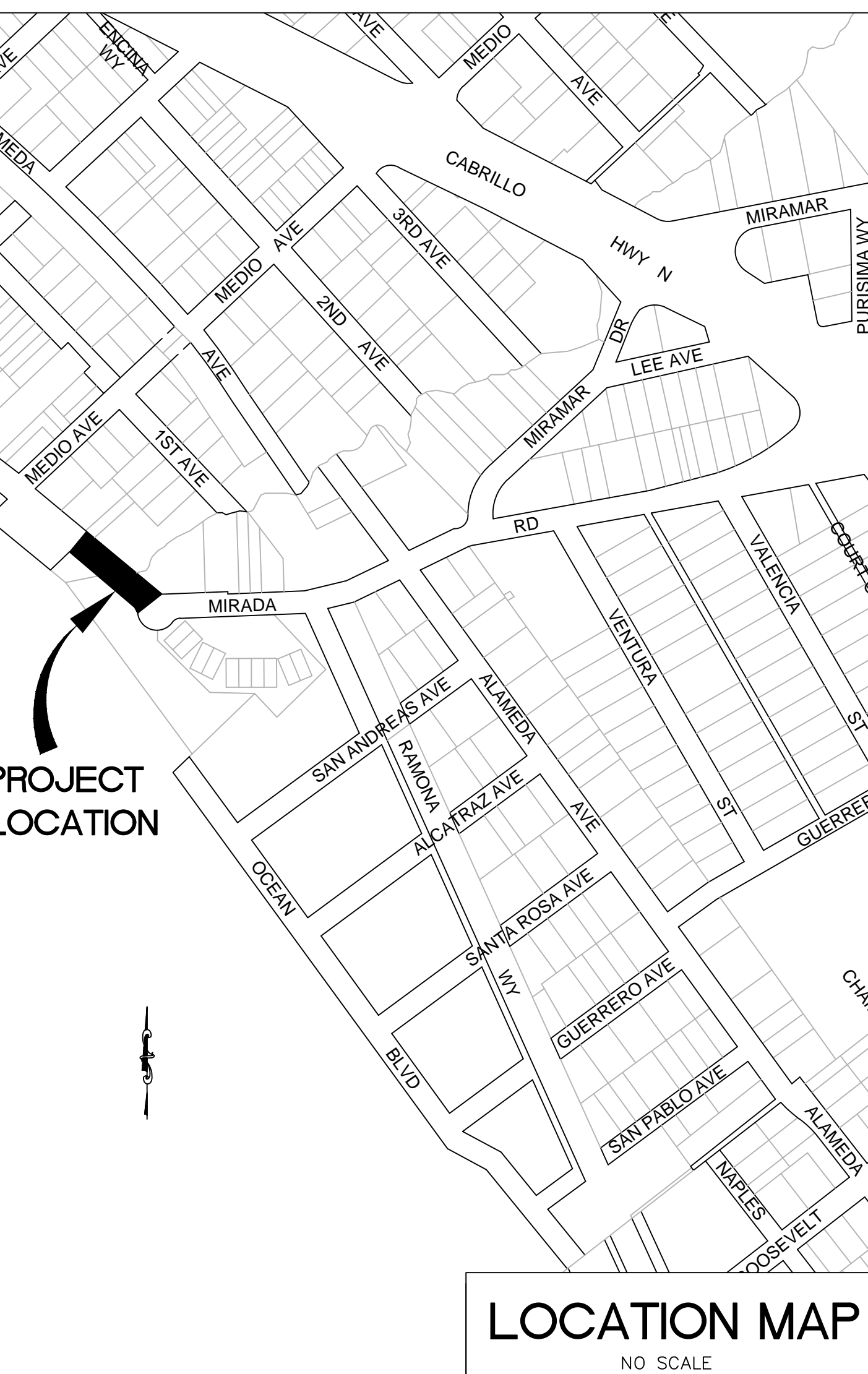
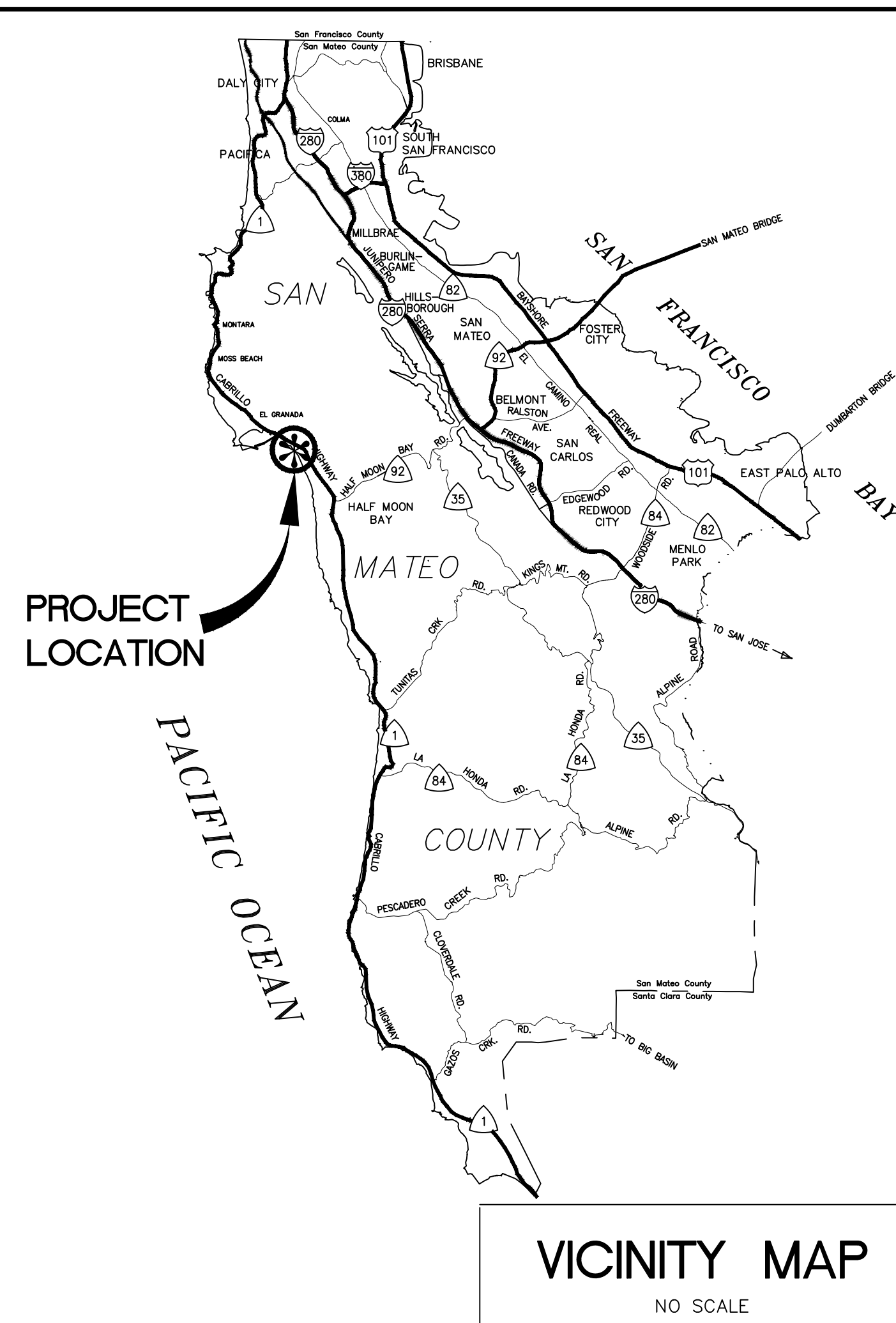

ABBREVIATIONS:

AC ASPHALTIC CONCRETE
BFP BACK FLOW PREVENTER
CL CENTER LINE
CP CONTROL POINT
CONC CONCRETE
DEP DEPRESSED
E ELECTRIC
ELEC ELECTRICAL
FDC FIRE DEPARTMENT CONNECTION
FH FIRE HYDRANT
FL FLOW LINE
G GAS
GV GAS VALVE
HV HIGH VOLTAGE
HYD HYDRANT
IRR IRRIGATION
L LIGHTING CONDUIT
RW RIGHT OF WAY
SD STORM DRAIN
SL STREET LIGHT
SS SANITARY SEWER
SUAS SMALL UNMANNED AERIAL SYSTEM
TBW TOP BACK OF WALL
TC TOP OF CURB
TELE TELEPHONE
TYP TYPICAL
TFW TOP FACE OF WALL
TW TOP OF WALL
W WATER
WV WATER VALVE

LEGEND:

SD STORM DRAIN LINE (EX)
SD STORM DRAIN LINE (EX) PROFILE
SS SANITARY SEWER LINE "ACTIVE"
SS SANITARY SEWER LINE "ACTIVE" PROFILE
W WATER LINE "ACTIVE"
W WATER LINE "ACTIVE" PROFILE
W ACP WATER LINE (Abn)
W ACP WATER LINE (Abn) PROFILE
G GAS LINE (Abn)
G GAS LINE (Abn) PROFILE
G GAS LINE "ACTIVE"
G GAS LINE "ACTIVE" PROFILE
JT JOINT COMMUNICATION LINE (EX)
JT JOINT COMMUNICATION LINE (EX) PROFILE
--- RIGHT OF WAY

LEGEND:

FIRE HYDRANT
FIRE HYDRANT MARKERS
MAILBOX
SIGN
MONUMENT
BENCHMARK
DRIVEWAY NUMBER
HOUSE NUMBER ADDRESS
DETAIL NUMBER AND SHEET
EXISTING TREE
FENCE / WALL
CLASS 1 FLEXIBLE OBJECT MARKER
NAIL AND WASHER
(xxx.xx) (xxx.xx) = EXISTING ELEVATION
xxx.xx = PROPOSED ELEVATION
+0.00 00.00 = STATION
(00.00) 00.00 = (EXIST ELE) PR ELE AT LIP OF GUTTER
WATER METER
WATER VALVE
GAS VALVE
JOINT UTILITY POLE
TELEPHONE POLE
GUY WIRE ANCHOR
SSMH SANITARY SEWER MANHOLE
SSCO SANITARY SEWER CLEANOUT
SSFI SANITARY SEWER FLUSHING INLET
SDMH STORM DRAIN MANHOLE
UD UNDERDRAIN
BBLBX BUBBLE-UP BOX
MH UNKNOWN MANHOLE

NOTES:

- CONTRACTOR SHALL CONFINE HIS OPERATIONS AND ACTIVITIES WITHIN THE PROJECT LIMITS, CONSISTING OF ROAD RIGHT-OF-WAY, RIGHTS OF ENTRY AND/OR PROJECT CONFORMS, AS SHOWN ON THE PLANS AND AS DIRECTED BY THE ENGINEER.
- CONTINUOUS DUST CONTROL SHALL BE PROVIDED AS REQUIRED BY SECTION 17 OF THE SPECIAL PROVISIONS AND AS DIRECTED BY THE ENGINEER.
- LOCATIONS AND DEPTHS OF EXISTING UTILITIES SHOWN ON THE PLANS ARE APPROXIMATE ONLY. CONTRACTOR SHALL BE RESPONSIBLE FOR CONTACTING THE UTILITIES TO DETERMINE EXACT LOCATIONS AND DEPTHS. CONTRACTOR SHALL CALL USA NORTH 811 (USA) UNDERGROUND SERVICE ALERT A MINIMUM OF FORTY-EIGHT (48) HOURS IN ADVANCE OF ANY EXCAVATION OR TRENCHING WORK. USA MAY BE CONTACTED EITHER ON-LINE AT USANORTH811.ORG OR BY PHONE BY DIALING (800) 227-2600 OR 811. WHEN CALLING, BE PREPARED TO GIVE LOCATION AND NATURE OF WORK, START DATE, COMPANY NAME, ADDRESS AND TELEPHONE NUMBER.
- PLANS MAY NOT SHOW ALL EXISTING WATER, GAS OR SANITARY SEWER LATERALS. CONTRACTOR SHALL BE RESPONSIBLE FOR VERIFICATION AND PRESERVATION OF ALL SUCH FACILITIES WHICH ARE NOT TO BE RELOCATED.
- CONTRACTOR IS ADVISED THAT EXCAVATION MAY CONFLICT WITH SANITARY SEWER LATERALS, GAS LINES, WATER LINES AND OTHER UNDERGROUND UTILITIES. ANY DAMAGE TO EXISTING FACILITIES CAUSED BY THE CONTRACTOR SHALL BE REPAIRED AT THE CONTRACTOR'S EXPENSE.
- DRIVEWAY OPENINGS AND CONFORM LOCATIONS SHOWN ARE APPROXIMATE ONLY. EXACT LOCATIONS WILL BE DETERMINED IN THE FIELD BY THE ENGINEER. SURFACED SHOULDER CONFORM LIMITS ARE AS INDICATED AT 3 FEET FROM OUTSIDE EDGE OF THE GUTTER, UNLESS DIRECTED OTHERWISE BY THE ENGINEER OR OTHERWISE NOTED ON THE PLANS.
- NO TREES, VEGETATION OR IMPROVEMENTS (INCLUDING FENCES) SHALL BE REMOVED WITHOUT THE PRIOR WRITTEN CONSENT AND APPROVAL OF THE ENGINEER. VEGETATION AND IMPROVEMENTS WHICH ARE DESIGNATED TO BE REMOVED SHALL BECOME THE PROPERTY OF THE CONTRACTOR, UNLESS OTHERWISE DIRECTED BY THE ENGINEER. REFER TO PROJECT SPECIAL PROVISIONS SECTION 16 REGARDING REQUIREMENTS FOR ADVANCE NOTIFICATION OF PROPERTY OWNERS.
- THE CONTRACTOR'S ATTENTION IS DIRECTED TO SECTION 5-1.07 OF THE STANDARD SPECIFICATIONS. THE SURVEY AND ASSOCIATED STAKING SHALL BE IN CONFORMANCE WITH SECTION 100, CONSTRUCTION STAKING AND LAYOUT OF THE SPECIAL PROVISIONS.
- WHEN DIRECTED BY THE ENGINEER, CUT AND FILL SLOPE RATIOS SHALL BE VARIED TO AVOID TREES OR OTHER EXISTING IMPROVEMENTS.
- CONTRACTOR SHALL EXERCISE CARE WHEN EXCAVATING NEAR TREES AND ROOTS OF TREES TO REMAIN. SEE SECTION 19 OF THE SPECIAL PROVISIONS.
- ANY DAMAGE, AS A RESULT OF THE CONTRACTOR'S OPERATION, TO PAVEMENT AND BASE MATERIAL THAT IS TO REMAIN SHALL BE REPAIRED, OR REMOVED AND REPLACED WITH SAME TYPE OF MATERIAL OR APPROVED EQUAL, AS DIRECTED BY THE ENGINEER, AND AT THE SOLE EXPENSE OF THE CONTRACTOR. THE ENGINEER SHALL BE THE SOLE JUDGE OF THE ADEQUACY OF THE COMPLETED REMEDIAL WORK.
- CONTRACTOR'S ATTENTION IS DIRECTED TO THE CONSTRUCTION CENTERLINE ALIGNMENTS LISTED BELOW:
"M-CL" LINE - MIRADA ROAD
(BETWEEN MEDIO AVENUE AND RAMONA WAY)

RECORD DRAWINGS

Resident Engineer _____
Date _____

**INFORMATION ONLY
NOT FOR CONSTRUCTION**

BENCHMARKS:

VERTICAL DATUM FOR THIS PROJECT IS NORTH AMERICAN VERTICAL DATUM OF 1988 (NAVD88) PER NATIONAL GEODETIC BENCHMARK DESIGNATED N1240. A GPS OPUS WAS PERFORMED AND NGS BENCHMARK N1240 WAS TIED OUT AND FOUND TO BE 0.17' ABOVE THE GPS ELEVATION. PREVIOUS SURVEYS IN THE AREA FOUND AN ERROR OF 0.19' WHEN TYING INTO N1240 AND HELD THE NGS BENCHMARK. BENCHMARK N1240 HELD FOR THIS SURVEY TO MATCH PREVIOUS SURVEY EFFORTS OF THE AREA. NGS BENCHMARK HT1441 WAS ALSO SEARCHED FOR AS A CHECK, BUT WAS NOT RECOVERED. BENCHMARK MAY HAVE BEEN DESTROYED OR BURIED.

BASIS OF BEARINGS:

5 MAPS 58, CORNER RECORD #0871B AND 112 M 47 HAVE VARYING BASIS OF BEARINGS. TO ACHIEVE 5 MAPS 58 AND CORNER RECORD #0871B BEARINGS ROTATE 01°02'08" TO BEARINGS SHOWN. TO ACHIEVE 112 M 47 BEARINGS ROTATE BEARINGS BY 00°01'14" TO BEARINGS SHOWN.

APPLICABLE STANDARD PLANS:

A20A

SHEET INDEX:

PAGE	TITLE	NAME
1	C01	TITLE SHEET & GENERAL NOTES
2	C02	EXISTING CONDITIONS
3	C03	BOUNDARY DETAIL
4	C04	DEMOLITION PLAN
5	C05	IMPROVEMENT PLAN
6	C06	CONSTRUCTION ACCESS PLAN
7	C07	BRIDGE PROFILE & SECTION PLAN
8	C003	BLUFF STABILIZATION PLAN
9	C004	BLUFF STABILIZATION CONCEPT
10	C005	BLUFF STABILIZATION DETAIL
11	S1	GENERAL BRIDGE PLAN
12	S2	ABUTMENT DETAILS

65% SUBMITTAL
JAN. 16, 2020
NOT FOR CONSTRUCTION

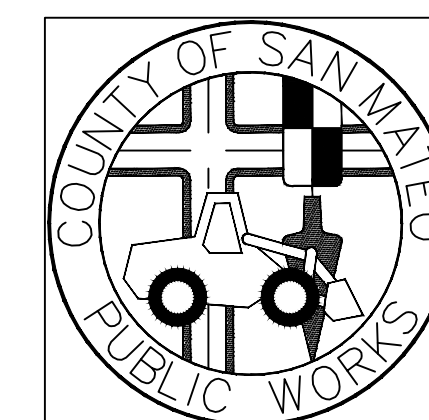

DESIGNED BY: RCS		TITLE SHEET & GENERAL NOTES		SCALE: AS SHOWN
CHECKED BY: RCS		MIRADA ROAD		DATE: 01/16/2020
DRAWN BY: MJV		JAMES C. PORTER, DIRECTOR OF PUBLIC WORKS SAN MATEO COUNTY		FILE NO.: 4122700
REVISION	DATE			
		555 COUNTY CENTER, 5th FLOOR REDWOOD CITY, CALIFORNIA 94063		C01 SHEET 1 OF 12

FOR REDUCED PLANS ORIGINAL SCALE IS IN INCHES

P:\044122700\DWG\Sheet_Drawing\01_TitleSheet_24x36.dwg 01/16/2020 10:53 AM michael 13.5602

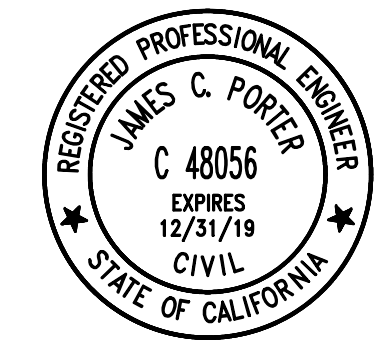

APPROVED: _____
 DATE: _____
 JAMES C. PORTER, DIRECTOR OF PUBLIC WORKS
 R. C. E. # 48056 / EXPIRES 12-31-2019

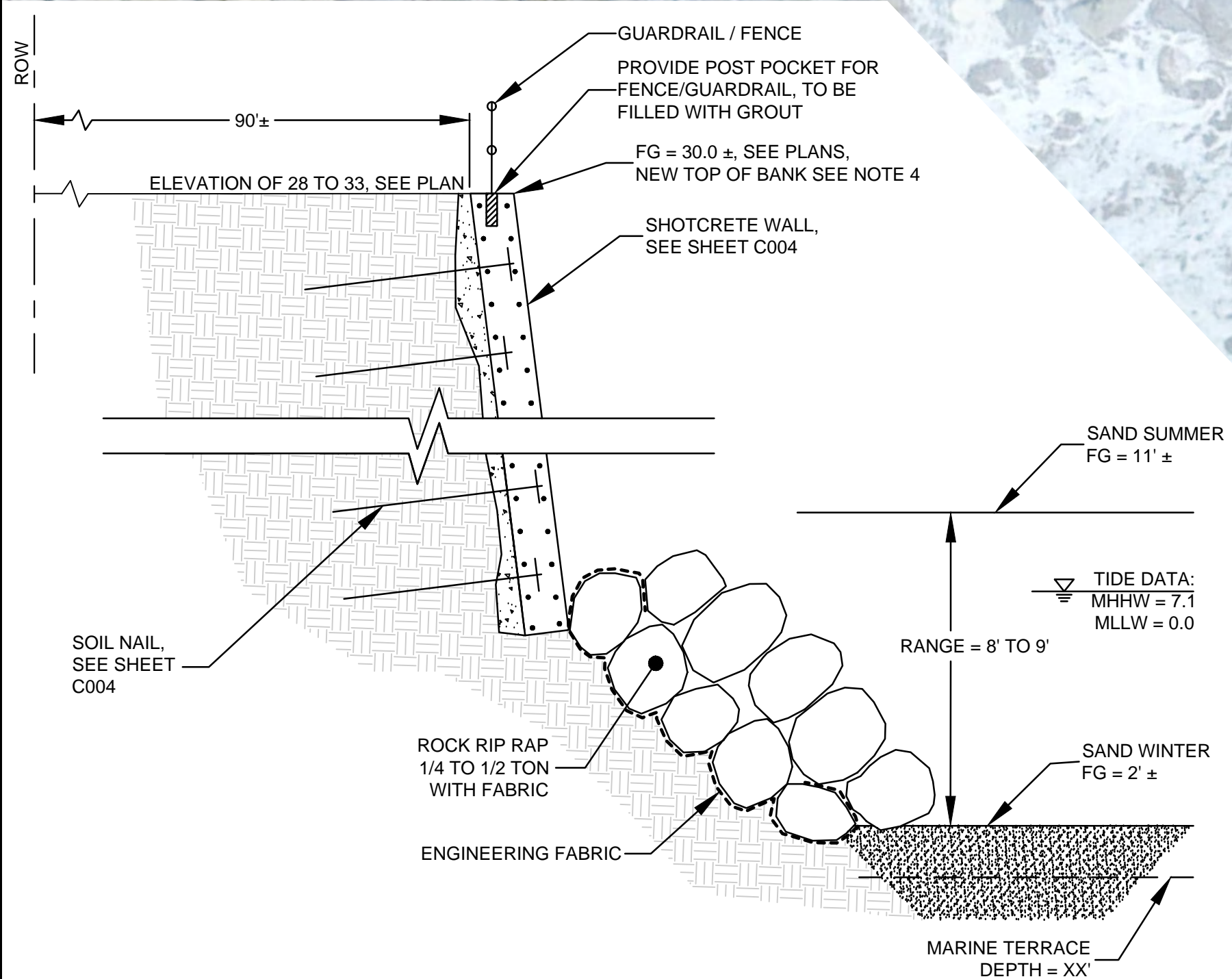

SECTION 5A: SHOTCRETE / REVETMENT WALL
 NOT TO SCALE (SEE SHEET C004 FOR ADDITIONAL DETAILS)

LEGEND

	BOUNDARY OFFSITE
	CONTOUR MAJOR (5' INTERVAL)
	CONTOUR MINOR (1' INTERVAL)
	FENCE
	GRADE BREAK LINE
	MONUMENT LINE
	RIGHT OF WAY
	SEWER
	STORM DRAIN
	TOE OF BANK, SEE NOTE 4
	TOP OF BANK, SEE NOTE 4

HATCH LEGEND

	NEW ASPHALT PAVING
	SHOTCRETE / REVETMENT WALL, SEE SECTION THIS SHEET, SEE NOTE 3

NOTES

- TO ACCESS THE SITE WITH CONSTRUCTION EQUIPMENT SEE SHEET C-50.
- ROUTE PG&E ELECTRICAL CONDUITS ALONG EACH SIDE OF THE NEW BRIDGE.
- THE EXISTING ROCK RIP RAP AT THE LOCATION WHERE THE SHOTCRETE / REVETMENT WALL CONFORMS INTO THE EXISTING ROCK RIP RAP SHALL BE REMOVED AND REPLACED IN A MANNER TO ENSURE IT IS STABILIZED.
- TOP OF BANK IS APPROXIMATELY THE LIMIT OF THE WATERS OF THE UNITED STATES.

ABBREVIATIONS

AC	ASPHALTIC CONCRETE	IRR	IRRIGATION
BFP	BACK FLOW PREVENTER	L	LIGHTING CONDUIT
CL	CENTER LINE	RW, ROW	RIGHT OF WAY
CP	CONTROL POINT	SD	STORM DRAIN
CONC	CONCRETE	SL	STREET LIGHT
DEP	DEPRESSED	SS	SANITARY SEWER
E	ELECTRIC	SUAS	SMALL UNMANNED AERIAL SYSTEM
ELEC	ELECTRICAL	TBW	TOP BACK OF WALL
FDC	FIRE DEPARTMENT CONNECTION	TC	TOP OF CURB
FH	FIRE HYDRANT	TELE	TELEPHONE
FL	FLOW LINE	TYP	TYPICAL
G	GAS	TWF	TOP FACE OF WALL
GV	GAS VALVE	TW	TOP OF WALL
HV	HIGH VOLTAGE	W	WATER
HYD	HYDRANT	WV	WATER VALVE

EARTHWORK & DISTURBED AREA QUANTITIES

EARTHWORK, CUBIC YARDS OF MATERIAL:
 CUT: 500 CUBIC YARDS (SEE DEMOLITION PLAN SHEET C04)
 FILL: 150 CUBIC YARDS
 NOTES: FILL MATERIAL DOES NOT TAKE INTO CONSIDERATION MATERIAL THAT MAY BE REUSED ON SITE

65% SUBMITTAL
 JAN. 16, 2020
 NOT FOR CONSTRUCTION

APPROVED DATE:	
NAME NAME, CITY ENGINEER	
HALF MOON BAY	
R.C.E. # 00000 / EXPIRES 00-00-0000	

APPROVED DATE:	
ROBERT C. STEVENS, P.E.	
CSW ST2 ENGINEERING GROUP, INC.	
R.C.E. # 058660 / EXPIRES 12-31-2020	

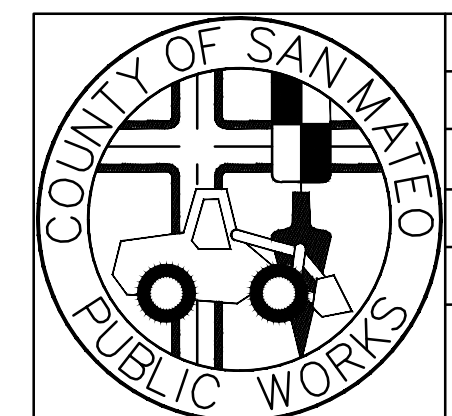

DESIGNED BY: RCS	IMPROVEMENT PLAN	SCALE: AS SHOWN
CHECKED BY: RCS		DATE: 01/16/2020
DRAWN BY: MJV		FILE NO.: 4122700
JAMES C. PORTER, DIRECTOR OF PUBLIC WORKS SAN MATEO COUNTY		555 COUNTY CENTER, 5th FLOOR REDWOOD CITY, CALIFORNIA 94063
REVISION	DATE	

FOR REDUCED PLANS ORIGINAL SCALE IS IN INCHES

 C05 SHEET 5 OF 12

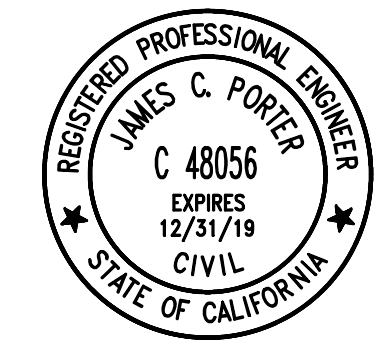

APPROVED: _____
 DATE: _____
 JAMES C. PORTER, DIRECTOR OF PUBLIC WORKS
 R. C. E. # 48056 / EXPIRES 12-31-2019

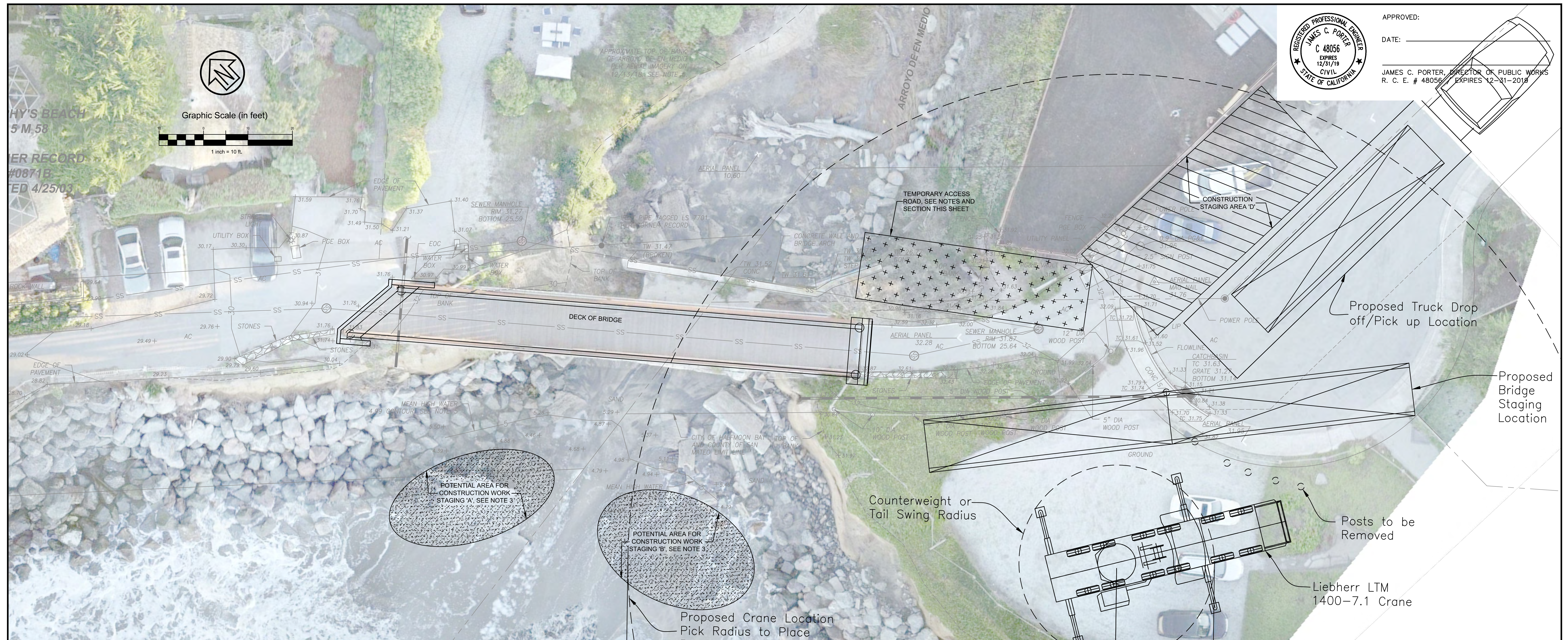

LEGEND

---	BOUNDARY OFFSITE
100	CONTOUR MAJOR (5' INTERVAL)
99	CONTOUR MINOR (1' INTERVAL)
---	FENCE
---	GRADE BREAK LINE
---	MONUMENT LINE
---	RIGHT OF WAY
SS	SEWER
---	STORM DRAIN
---	TOE OF BANK
---	TOP OF BANK

ABBREVIATIONS

AC	ASPHALTIC CONCRETE	RW	RIGHT OF WAY
CL	CENTER LINE	SD	STORM DRAIN
CONC	CONCRETE	SL	STREET LIGHT
ELEC	ELECTRICAL	SS	SANITARY SEWER
FDC	FIRE DEPARTMENT CONNECTION	TBW	TOP BACK OF WALL
FL	FLOW LINE	TC	TOP OF CURB
G	GAS	TYP	TYPICAL
GV	GAS VALVE	TFW	TOP FACE OF WALL
HV	HIGH VOLTAGE	TW	TOP OF WALL
IRR	IRRIGATION	W	WATER

- NOTES**
- ACCESS TO THE SITE FOR REMOVAL OF RSP WOULD OCCUR VIA CONSTRUCTION OF A TEMPORARY ACCESS ROAD FROM THE BRIDGE PLATEAU ON THE SOUTHEAST SIDE OF THE MIRADA ROAD PEDESTRIAN BRIDGE (UPSTREAM, LEFT BANK SIDE OF ARROYO DE EN MEDIO CREEK), AS SHOWN IN THE PLAN ON THIS SHEET.
 - APPROXIMATELY 30-40 CUBIC YARDS OF TEMPORARY FILL CONSISTING OF VARIOUSLY GRADED ROCKS AND BOULDERS WILL BE NEEDED TO SMOOTH AN APPROXIMATELY 15 FEET WIDE AND 60 FEET LONG TEMPORARY ACCESS PATH FOR THE EXCAVATOR. ACCESS WOULD BE PROVIDED DIRECTLY FROM THE BRIDGE PLATEAU TOWARDS ARROYO DE EN MEDIO CREEK. A PORTABLE MAT SYSTEM WILL BE INSTALLED FOR THE EXCAVATOR TO PREVENT IMPACTS TO THE CREEK CHANNEL AND BEACH. IF THE CREEK IS FLOWING DURING THE CONSTRUCTION PERIOD, WATER WILL BE DIVERTED VIA A FLEXIBLE PIPE TO DIVERT WATER AWAY FROM THE WORK AREA AND ALLOW ACCESS THROUGH THE CHANNEL. AREAS SHOWN ARE ONLY TO BE USED AS NECESSARY, WHEN CONSTRUCTION EQUIPMENT SUCH AS AN EXCAVATOR IS REQUIRED FOR REMOVAL AND REPLACEMENT OF RSP. SUCH OPERATIONS WILL BE IN ACCORDANCE WITH PERMITTING CONDITIONS, INCLUDING ADHERENCE TO PROPER BMPS AND WITHIN TIDAL WINDOWS FOR LOW TIDE.
 - THE AREA SHOWN AS THE CONSTRUCTION STAGING AREA IS PRIVATE PROPERTY AND SHALL ONLY BE USED WITH CONSENT FROM THE PROPERTY OWNER.

EARTHWORK & DISTURBED AREA QUANTITIES

EARTHWORK, CUBIC YARDS OF MATERIAL:
 CUT: 500 CUBIC YARDS (SEE DEMOLITION PLAN SHEET C04)
 FILL: 150 CUBIC YARDS (SEE IMPROVEMENT PLAN SHEET C05)

NOTE: CUT AND FILL MATERIAL DOES NOT TAKE INTO CONSIDERATION MATERIAL THAT MAY BE REUSED ON SITE

DISTURBED CORPS JURISDICTION AREA:
 TOTAL: 1,500 SF (APPROXIMATE)

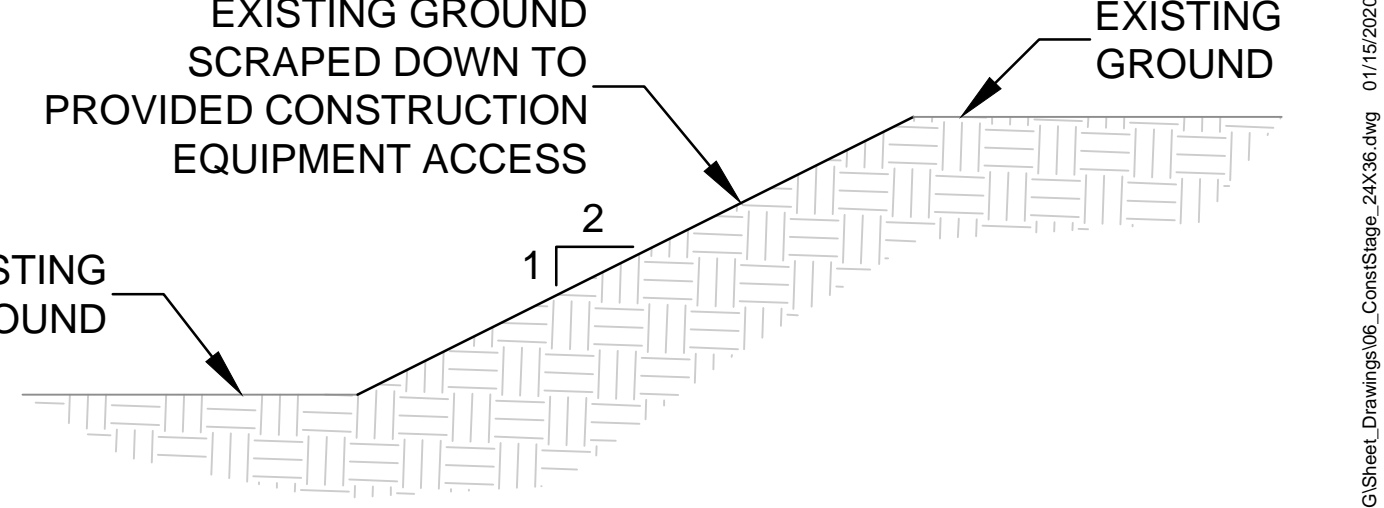

HATCH LEGEND

---	TEMPORARY ACCESS ROAD, SEE SECTION THIS SHEET
---	CONSTRUCTION STAGING, SEE NOTE 3
---	CONSTRUCTION STAGING AREA

65% SUBMITTAL
 JAN. 16, 2020
 NOT FOR CONSTRUCTION

APPROVED DATE:		APPROVED DATE:	
NAME NAME, CITY ENGINEER		ROBERT C. STEVENS, P.E.	
HALF MOON BAY		CSW S2 ENGINEERING GROUP, INC.	
R.C.E. # 00000 / EXPIRES 00-00-0000		R.C.E. # 058660 / EXPIRES 12-31-2020	

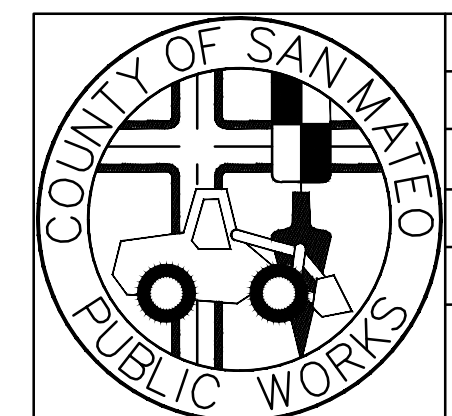

DESIGNED BY: RCS		CONSTRUCTION ACCESS PLAN		SCALE: AS SHOWN
CHECKED BY: RCS		MIRADA ROAD		DATE: 01/16/2020
DRAWN BY: MJV		JAMES C. PORTER, DIRECTOR OF PUBLIC WORKS SAN MATEO COUNTY		FILE NO.: 4122700
REVISION		DATE		555 COUNTY CENTER, 5th FLOOR REDWOOD CITY, CALIFORNIA 94063
				C06 SHEET 6 OF 12



P:\044122700\DWG\Sheet_Drawing\06_ConstrStage_24x36.dwg 01/16/2020 - 02:30 PM mcbahat 1:3.5602

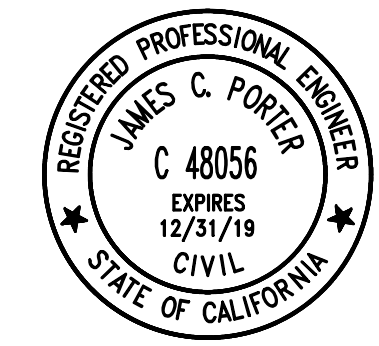

APPROVED: _____
 DATE: _____
 JAMES C. PORTER, DIRECTOR OF PUBLIC WORKS
 R. C. E. # 48056 / EXPIRES 12-31-2019

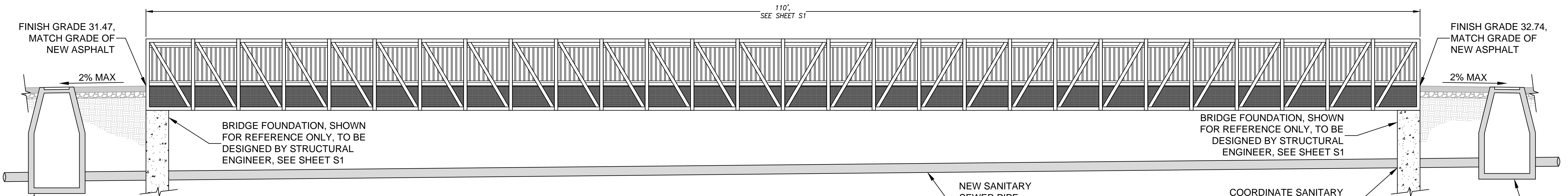
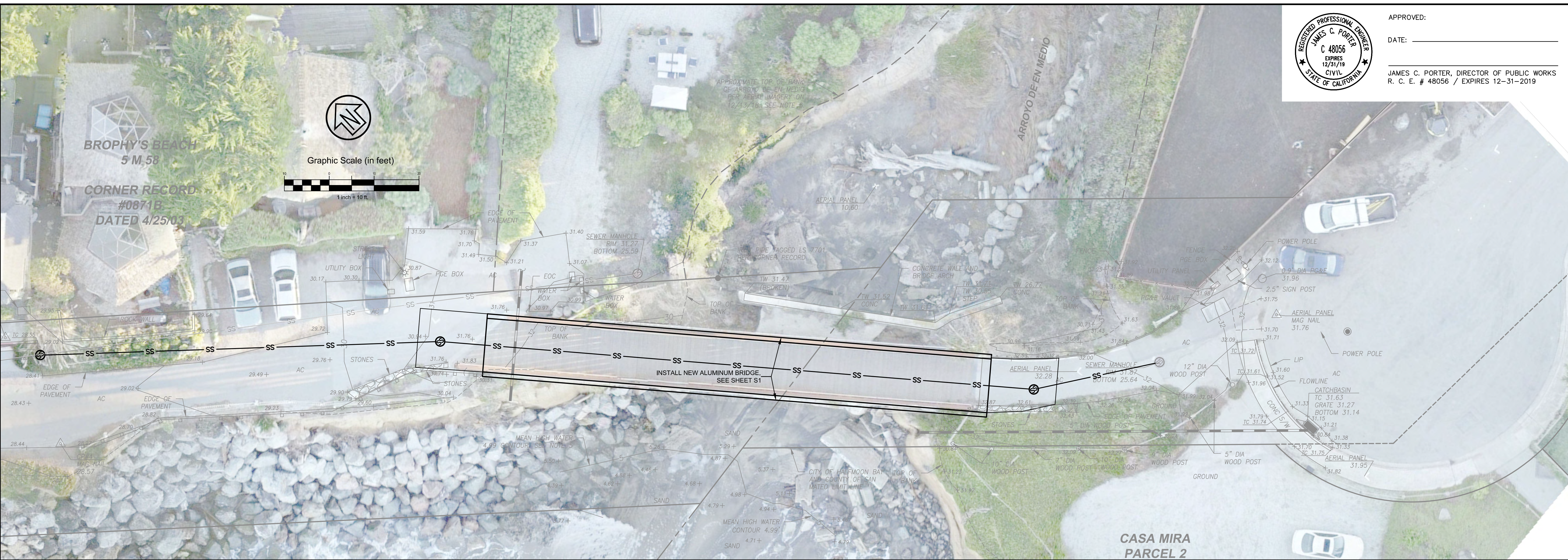

- NOTES**
- BRIDGE SHALL BE A WELDED ALUMINUM BRIDGE WITH NON-SLIP DECKING.
 - BRIDGE DESIGN, PROFILE AND SECTION ARE PRELIMINARY AND SHOWN FOR REFERENCE ONLY.

BRIDGE PROFILE
 (FOR REFERENCE ONLY, SEE SHEET S1)

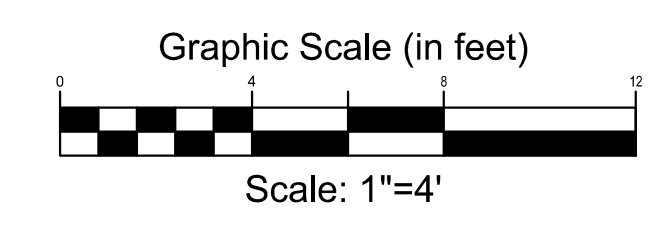

BRIDGE SECTION

NEW UTILITY PIPES AND/OR CONDUITS, EXACT LOCATION AND BRIDGE CONNECTION DETAILS SHALL BE PER MANUFACTURERS SPECIFICATIONS AND SHALL BE COORDINATED WITH ULTIMATE UTILITY LAYOUT.

65% SUBMITTAL
 JAN. 16, 2020
 NOT FOR CONSTRUCTION

APPROVED DATE:	
NAME NAME, CITY ENGINEER	
HALF MOON BAY	
R.C.E. # 00000 / EXPIRES 00-00-0000	

APPROVED DATE:	
ROBERT C. STEVENS, P.E.	
CSW ST2 ENGINEERING GROUP, INC.	
R.C.E. # 058660 / EXPIRES 12-31-2020	

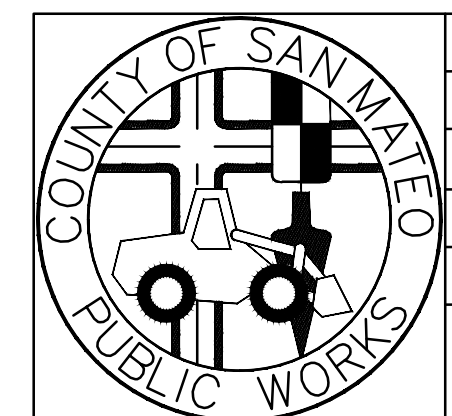

DESIGNED BY: RCS	BRIDGE PROFILE & SECTION PLAN MIRADA ROAD	SCALE: AS SHOWN
CHECKED BY: RCS		DATE: 01/16/2020
DRAWN BY: MJV		FILE NO.: 4122700
JAMES C. PORTER, DIRECTOR OF PUBLIC WORKS SAN MATEO COUNTY		555 COUNTY CENTER, 5th FLOOR REDWOOD CITY, CALIFORNIA 94063
REVISION	DATE	
FOR REDUCED PLANS ORIGINAL SCALE IS IN INCHES		
		0 1 2 3 4
		C07 SHEET 7 OF 12

P:\044122700\DWG\Sheet_Drawing\07_Bridge_24x36.dwg 01/15/2020 02:31 PM michael 1:3.9602

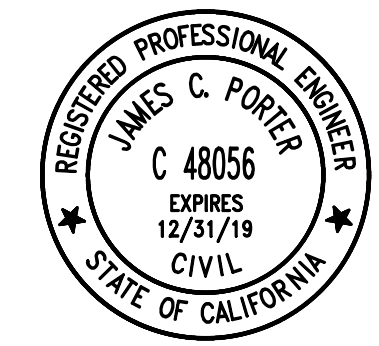

APPROVED: _____
 DATE: _____
 JAMES C. PORTER, DIRECTOR OF PUBLIC WORKS
 R. C. E. # 48056 / EXPIRES 12-31-2019

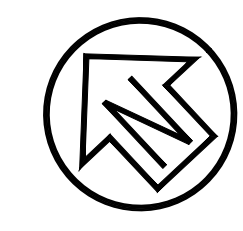

BROPHY'S BEACH
 5 M 58
CORNER RECORD
 #0871B
 DATED 4/25/03

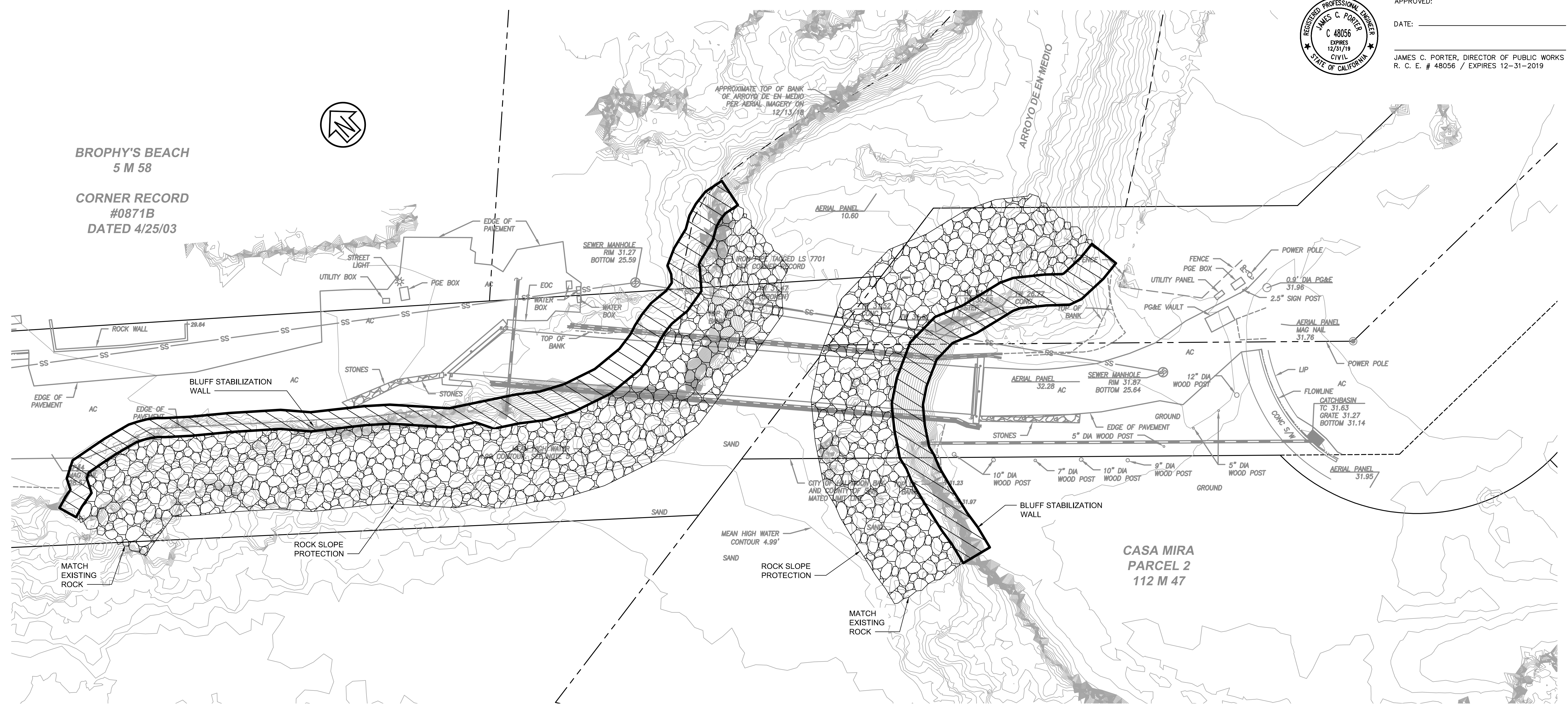

BLUFF STABILIZATION PLAN
 SCALE: 1" = 10'

- NOTES:**
1. THE LIMITS, LENGTH AND ALIGNMENT FOR THE BLUFF STABILIZATION SHOWN ON THIS DRAWINGS IS APPROXIMATE. CONTRACTOR SHALL FOLLOW THE SURFACE OF THE EXISTING BLUFF.
 2. ROCK SLOPE PROTECTION NOT SHOWN FOR CLARITY.

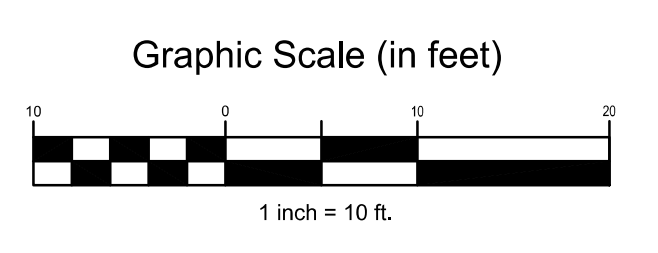

65% SUBMITTAL
 JAN. 16, 2020
 NOT FOR CONSTRUCTION

APPROVED DATE:	
NAME NAME, CITY ENGINEER	
HALF MOON BAY	
R.C.E. # 00000 / EXPIRES 00-00-0000	

APPROVED DATE:	
	2185 N. CALIFORNIA BLVD., SUITE 500 WALNUT CREEK, CA 94596 925-944-5411
DILIP R. TRIVEDI	
MOFFATT & NICHOL	
R.C.E. # XXXXXX / EXPIRES XX-XX-XXXX	

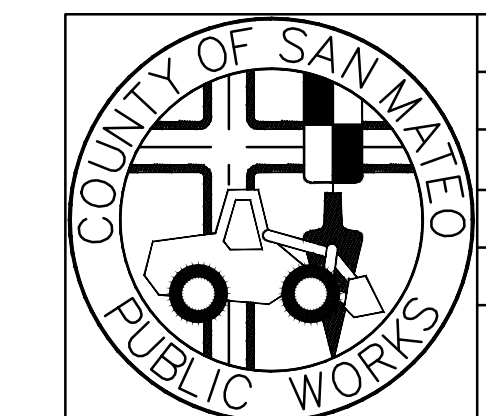

DESIGNED BY: DAJ	MIRADA ROAD BRIDGE AND BLUFF STABILIZATION	SCALE: AS SHOWN
CHECKED BY: JFJ	BLUFF STABILIZATION PLAN	DATE: 01/16/2020
DRAWN BY: PH		FILE NO.: XXXXXX
JAMES C. PORTER, DIRECTOR OF PUBLIC WORKS	SAN MATEO COUNTY	555 COUNTY CENTER, 5th FLOOR REDWOOD CITY, CALIFORNIA 94063
REVISION	DATE	
FOR REDUCED PLANS ORIGINAL SCALE IS IN INCHES		0 1 2 3 4
		C003 SHEET 8 OF 12

©\WC\10405 mirada road bridge and bluff stabilization\CAD\Drawings\sheet\10405-003.dwg 01/16/2020 - 02:15 PM ababane 1,2

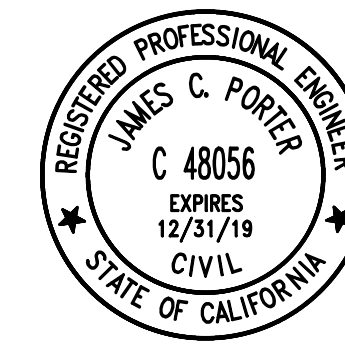

APPROVED: _____
 DATE: _____
 JAMES C. PORTER, DIRECTOR OF PUBLIC WORKS
 R. C. E. # 48056 / EXPIRES 12-31-2019

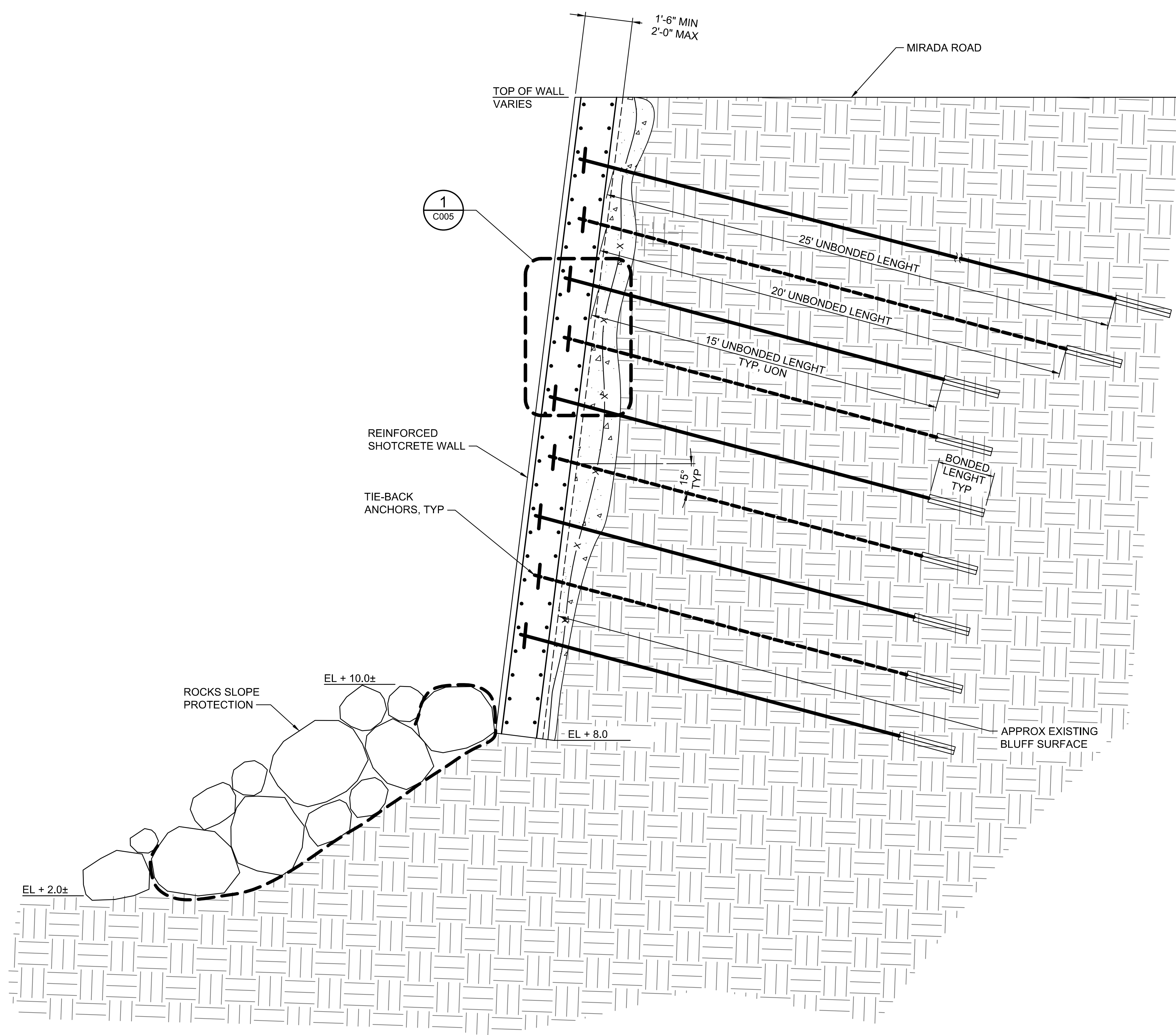

A SECTION
 SCALE: 3/8" = 1'-0"

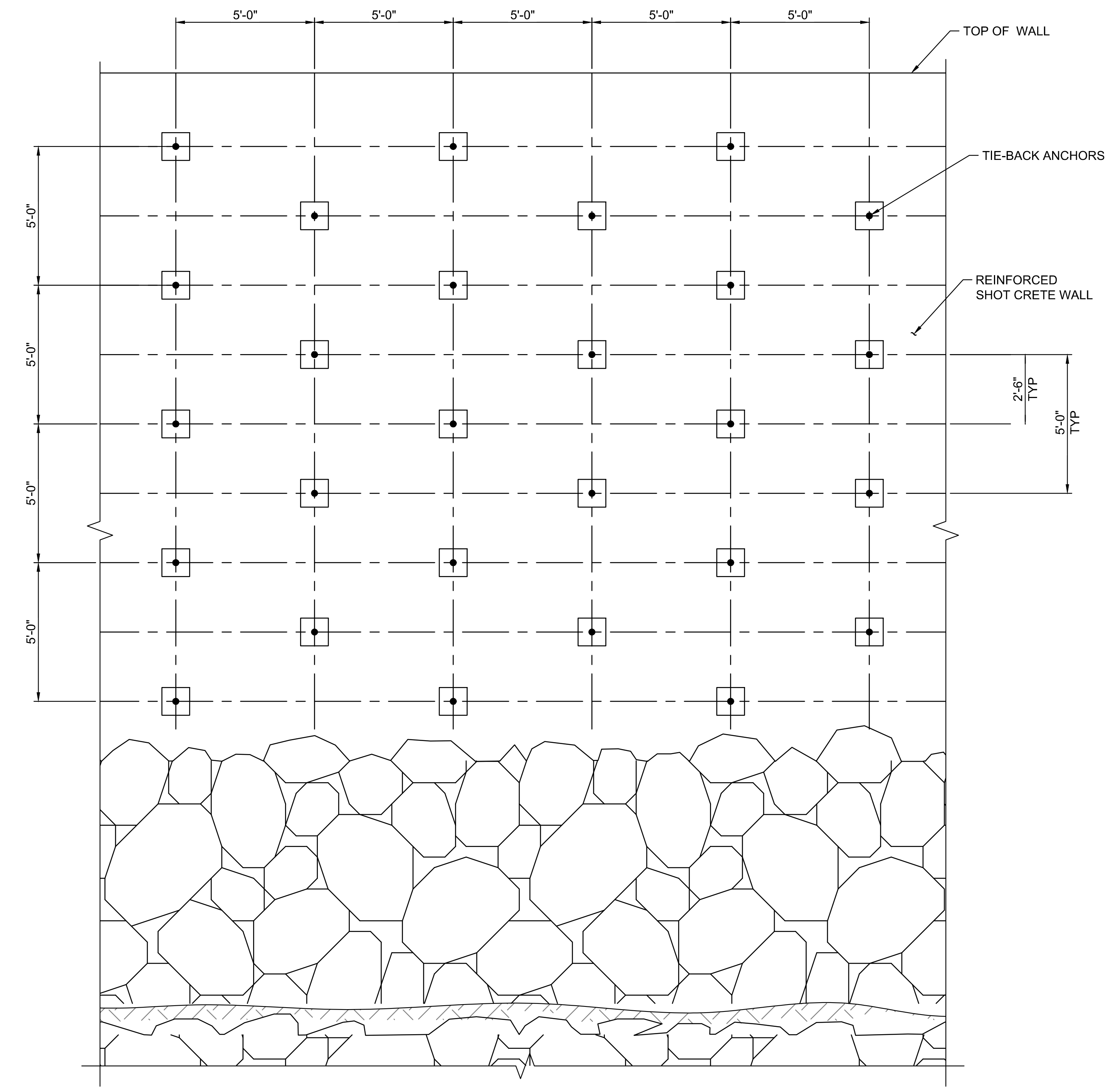

B ELEVATION
 SCALE: 3/8" = 1'-0"

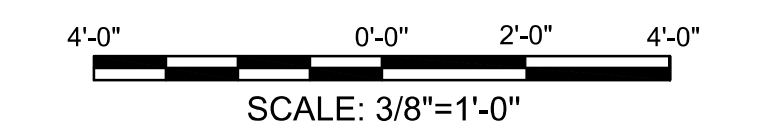

65% SUBMITTAL
 JAN. 16, 2020
 NOT FOR CONSTRUCTION

APPROVED DATE:	
NAME, CITY ENGINEER	
HALF MOON BAY	
R.C.E. # 00000 / EXPIRES 00-00-0000	

APPROVED DATE:	
2185 N. CALIFORNIA BLVD., SUITE 500 WALNUT CREEK, CA 94596 925-944-5411	
moffatt & nichol	
DILIP R. TRIVEDI	
MOFFATT & NICHOL	
R.C.E. # XXXXXX / EXPIRES XX-XX-XXXX	

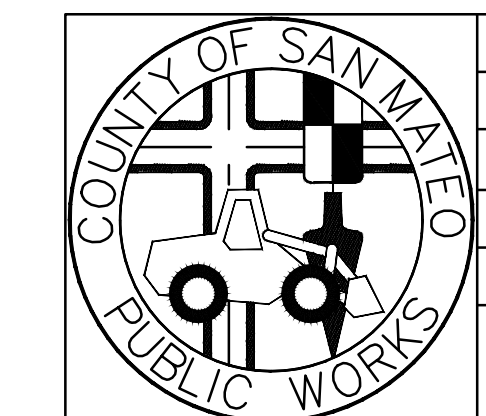

DESIGNED BY: DAJ	MIRADA ROAD BRIDGE AND BLUFF STABILIZATION	SCALE: AS SHOWN
CHECKED BY: JFJ	BLUFF STABILIZATION CONCEPT	DATE: 01/16/2020
DRAWN BY: PH		FILE NO.: XXXXXX
JAMES C. PORTER, DIRECTOR OF PUBLIC WORKS SAN MATEO COUNTY		555 COUNTY CENTER, 5th FLOOR REDWOOD CITY, CALIFORNIA 94063
REVISION	DATE	
FOR REDUCED PLANS ORIGINAL SCALE IS IN INCHES		
		C004 SHEET 9 OF 12

©\WC\10405 mirada road bridge and bluff stabilization\4_CADD_Active\sheet\10405C-004.dwg 01/16/2020 - 02:15 PM ababane 1,2

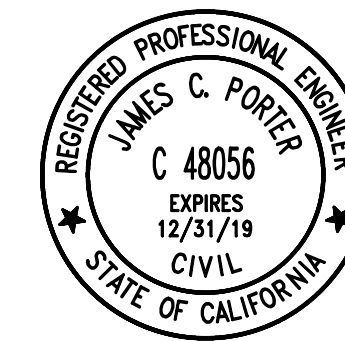

APPROVED: _____

DATE: _____

JAMES C. PORTER, DIRECTOR OF PUBLIC WORKS
R. C. E. # 48056 / EXPIRES 12-31-2019

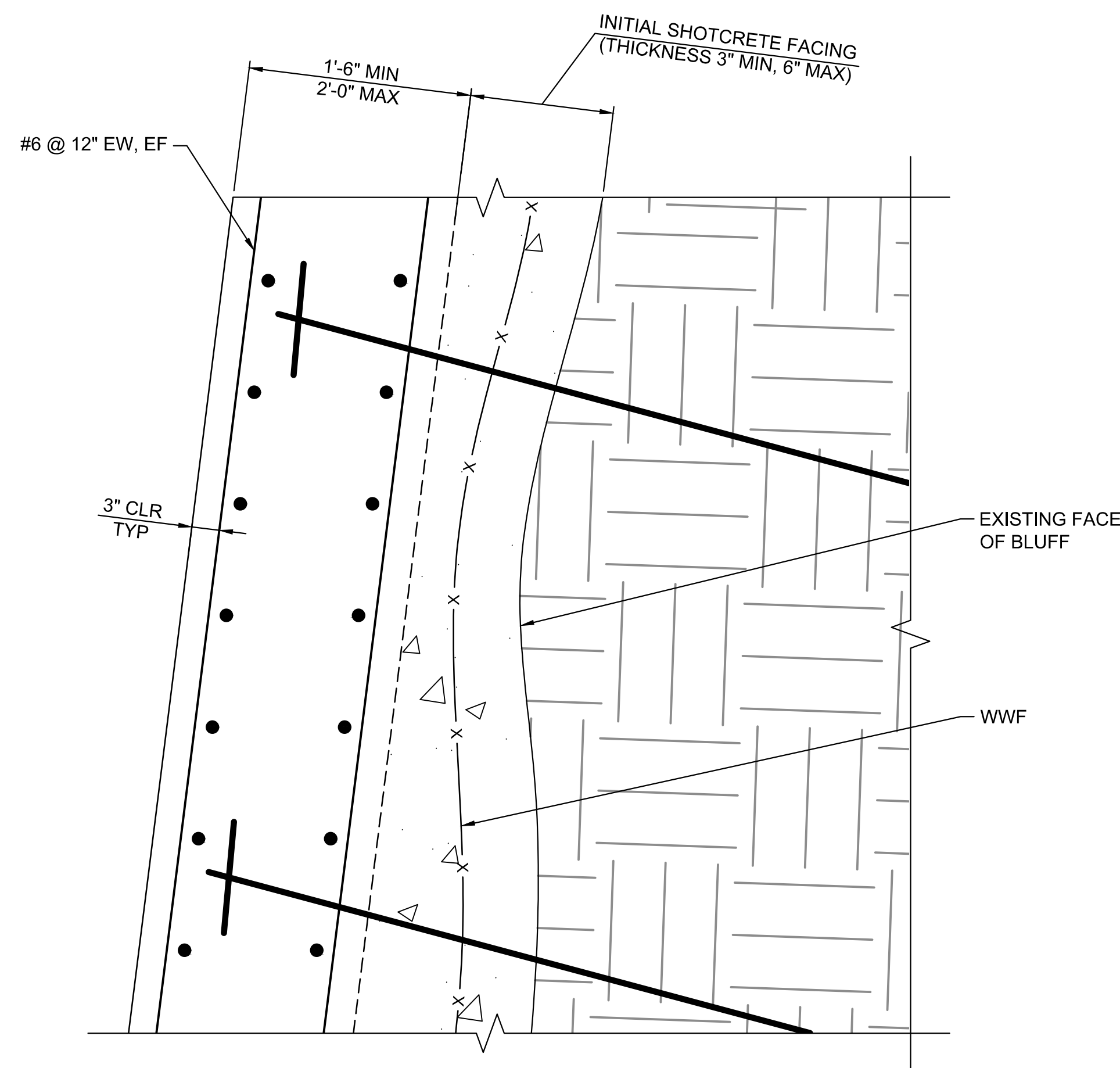

1 STEEL-REINFORCEMENT DETAIL
SCALE: 1" = 1'-0"

NOTES:

1. TIE-BACK ANCHOR IS A DESIGN-BUILD SYSTEM.
2. PRESSURE-GROUTED ANCHORS SHALL BE USED.
3. CONTRACTOR SHALL DETERMINE DRILLING AND GROUTING METHOD FOR TIE-BACK ANCHORS, INCLUDING BOND LENGTH.
4. EACH TIE-BACK ANCHORS SHALL HAVE A MINIMUM DESIGN CAPACITY OF 30 KIPS.
5. THE BOND STRESS FOR DESIGN OF ANCHOR BOND LENGTH DEPENDS ON FACTORS SUCH AS INSTALLATION TECHNIQUE, GROUTING PROCEDURE, DIAMETER OF HOLE, ETC. FOR PRELIMINARY ESTIMATE, THE PRESUMPTIVE ULTIMATE BOND STRESS IS ON THE ORDER OF 4.5 KSF.
6. ANCHORS SHALL BE CONSTRUCTED AND TESTED PER CALTRANS SPECIFICATION 46-02. AT LEAST 5% OF TOTAL NUMBER OF ANCHORS SHALL BE PERFORMANCE TESTED. THE REMAINING ANCHORS SHALL BE PROOF-TESTED.

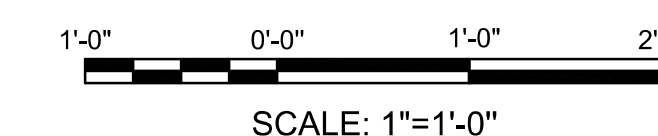

65% SUBMITTAL
JAN. 16, 2020
NOT FOR CONSTRUCTION

APPROVED DATE:	
NAME NAME, CITY ENGINEER	
HALF MOON BAY	
R.C.E. # 00000 / EXPIRES 00-00-0000	

APPROVED DATE:	
2185 N. CALIFORNIA BLVD, SUITE 500 WALNUT CREEK, CA 94596 925-944-5411	
DILIP R. TRIVEDI	
MOFFATT & NICHOL	
R.C.E. # XXXXXX / EXPIRES XX-XX-XXXX	

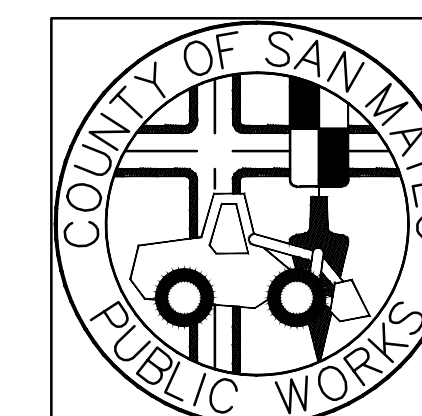

DESIGNED BY: DAJ	MIRADA ROAD BRIDGE AND BLUFF STABILIZATION	SCALE: AS SHOWN
CHECKED BY: JFJ	BLUFF STABILIZATION DETAIL 1 OF 2	DATE: 01/16/2020
DRAWN BY: PH		FILE NO.: XXXXXX
JAMES C. PORTER, DIRECTOR OF PUBLIC WORKS	555 COUNTY CENTER, 5th FLOOR	
SAN MATEO COUNTY	REDWOOD CITY, CALIFORNIA 94063	
REVISION	DATE	
FOR REDUCED PLANS ORIGINAL SCALE IS IN INCHES		
		C005 SHEET 10 OF 12

C:\WC\10405 mirada road bridge and bluff stabilization\4_CADD_Active_sheets\10405C-005.dwg 01/16/2020 - 02:15 PM ababane 1,2

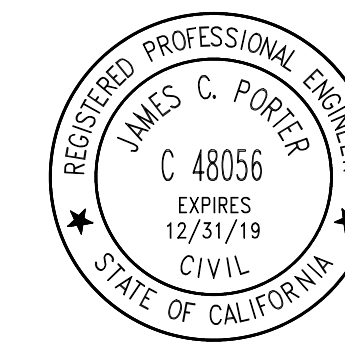

APPROVED: _____
 DATE: _____
 JAMES C. PORTER, DIRECTOR OF PUBLIC WORKS
 R. C. E. # 48056 / EXPIRES 12-31-2019

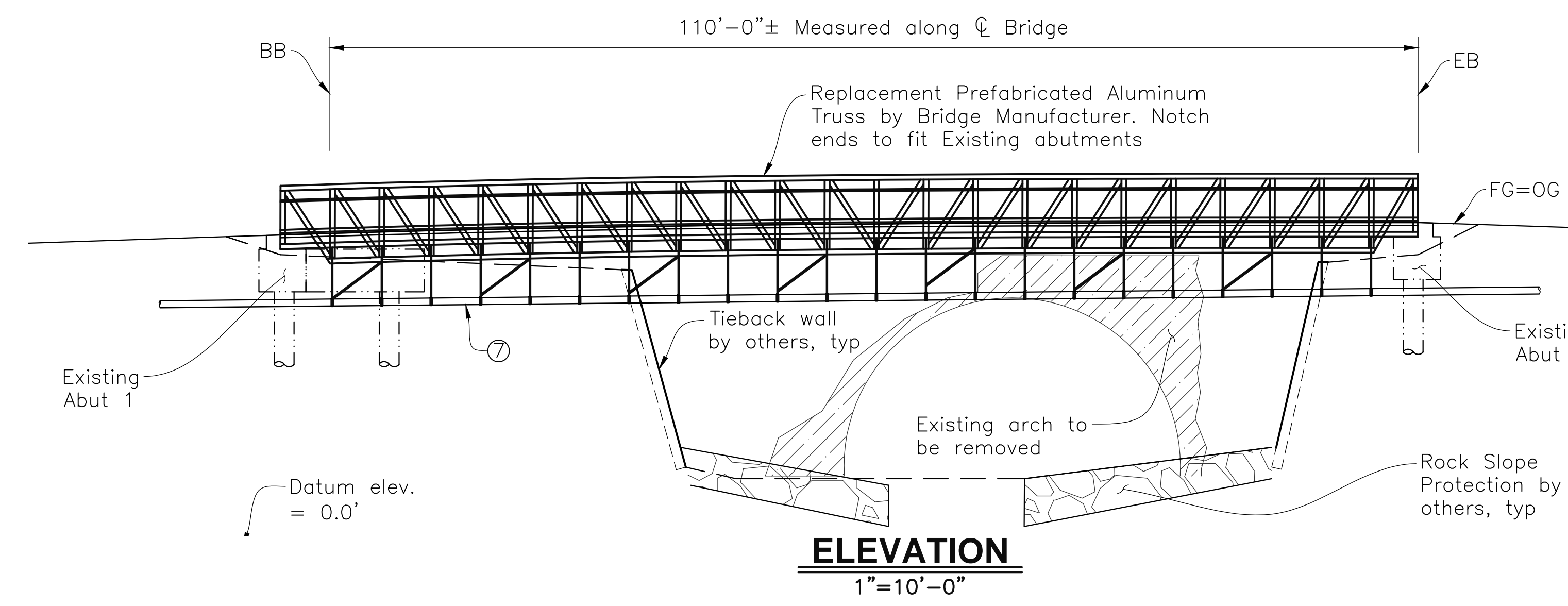

ELEVATION
 1"=10'-0"

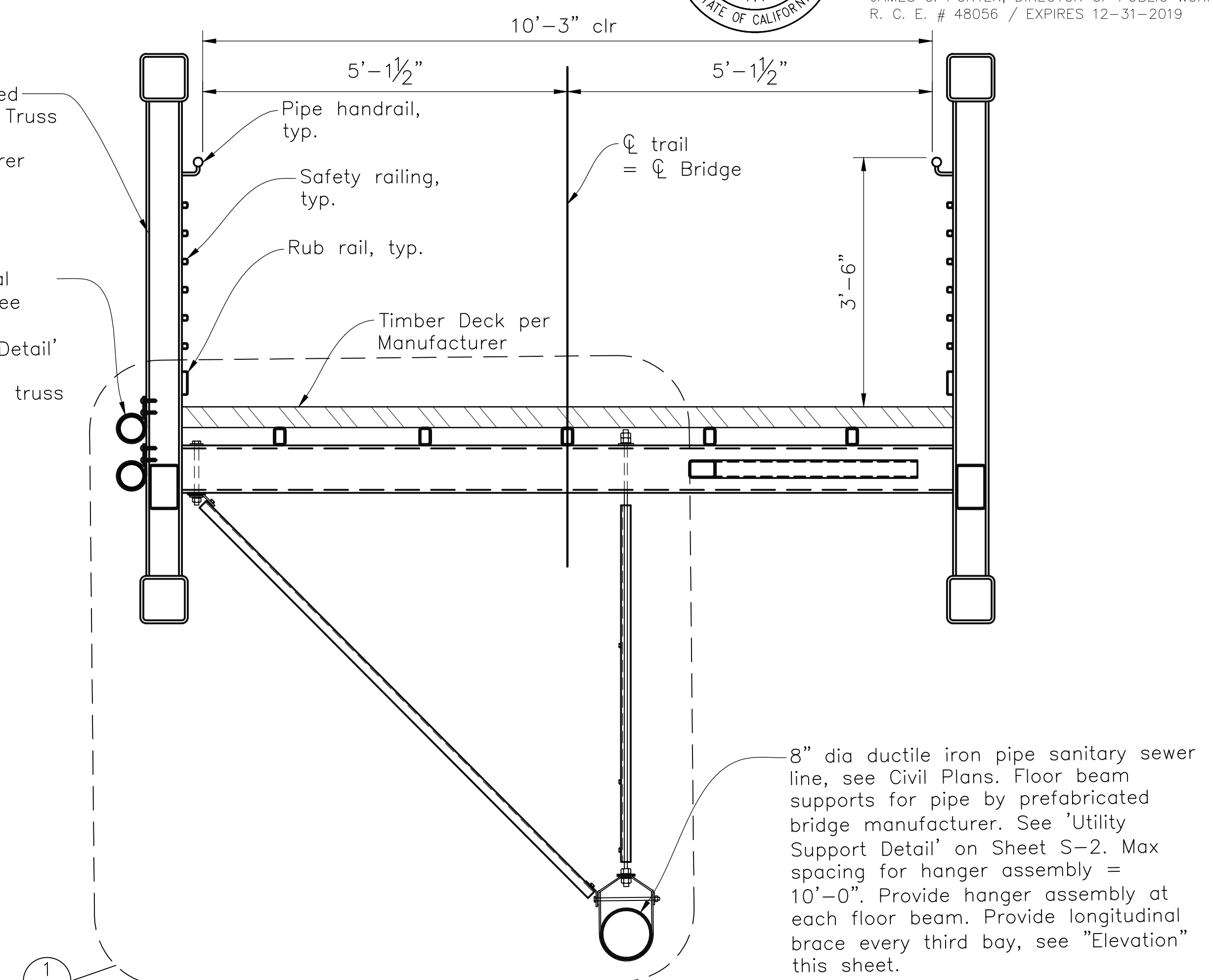

TYPICAL SECTION
 3/4"=1'-0"

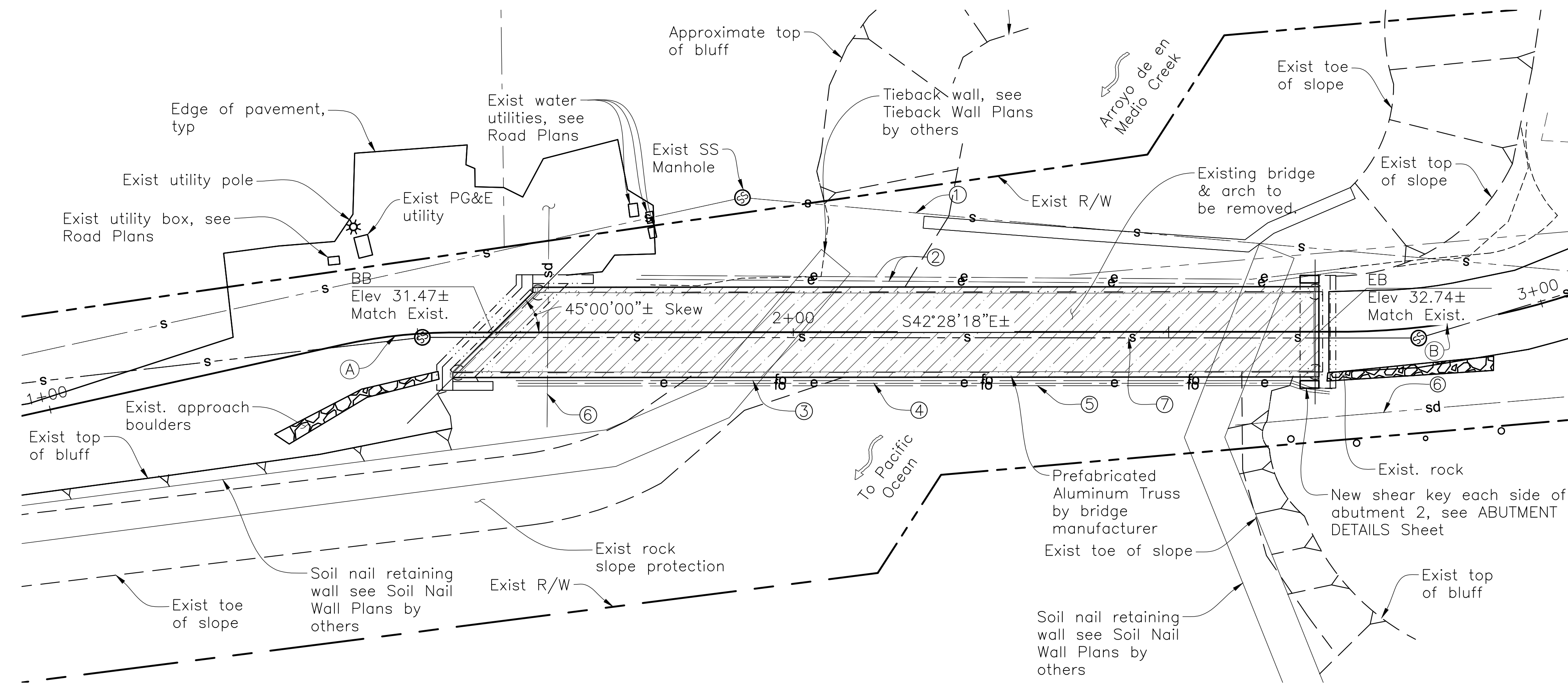

PLAN
 1"= 10'-0"

CALTRANS 2006 STANDARD PLANS

- A10A ACRONYMS & ABBREVIATIONS (SHEET 1 OF 2)
- A10B ACRONYMS & ABBREVIATIONS (SHEET 2 OF 2)
- A10C SYMBOLS (SHEET 1 OF 2)
- A10D SYMBOLS (SHEET 2 OF 2)

Legend

- Existing arch to be removed
- Indicates new construction
- Indicates existing bridge
- ① Existing sewer pipe to be relocated
- ② Existing 2'-4" ø electrical conduits (galv.) intended for future use to be relocated (PG&E).
- ③ Existing 4" ø conduit (galv.) to be relocated (AT&T).
- ④ Existing 2" ø electrical conduit (galv.) to be relocated.
- ⑤ Existing 2" ø conduit (galv.) to be relocated (Pacbell).
- ⑥ Existing storm drain to remain.
- ⑦ 8" ø sewer line, see Civil Plans

Notes:

1. These plans shall incorporate the State of California, Department of Transportation, Standard Specifications and Standard Plans dated 2006, and the Project Special Provisions.
2. The contractor shall verify all controlling field dimensions before ordering or fabricating any material.
3. Bridge shall be made from Aluminum as specified by prefabricated bridge manufacturer.
4. Prefabricated truss bridge length shall be verified by the Contractor with in-place location of abutments.
5. Surveyor shall verify layout and elevation control.
6. Utility locations shown schematically. Contractor to verify all utilities with Civil Plans.

INDEX TO BRIDGE PLANS

SHEET No.	TITLE
S-1	GENERAL PLAN
S-2	ABUTMENT DETAILS

- Indicates section letter
- Indicates sheet no. shown on
- Indicates detail no.
- Indicates sheet no. shown on

CURVE DATA			
CURVE	R	Δ	L
(A)	68.58'	18°47'06"	14.36'
(B)	38.37'	11°42'46"	100.00'

Verify Curve Data with Civil Plans

65% SUBMITTAL
 JAN. 16, 2020
 NOT FOR CONSTRUCTION

APPROVED DATE: _____

NAME: _____, CITY ENGINEER
 HALF MOON BAY
 R.C.E. # 00000 / EXPIRES 00-00-0000

APPROVED DATE: _____

NARCISO R. ZERMENO, S.E.
 CORNERSTONE STRUCTURAL ENGINEERING GROUP
 R.S.E. # S6783 / EXPIRES 3-31-2020

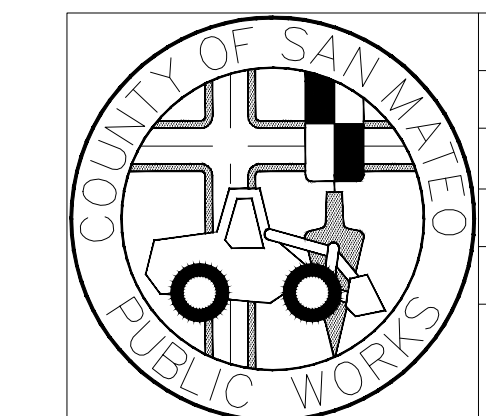
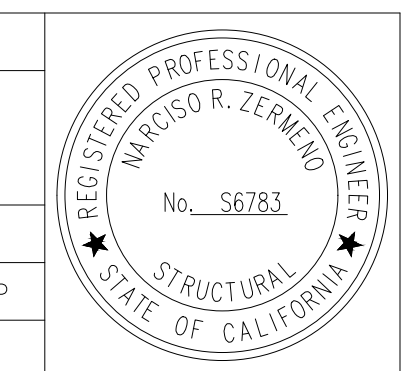

REVISION	DATE

DESIGNED BY: NRZ
 CHECKED BY: -
 DRAWN BY: TLW
 JAMES C. PORTER, DIRECTOR OF PUBLIC WORKS
 SAN MATEO COUNTY

GENERAL BRIDGE PLAN
 MIRADA ROAD

555 COUNTY CENTER, 5th FLOOR
 REDWOOD CITY, CALIFORNIA 94063

FOR REDUCED PLANS ORIGINAL SCALE IS IN INCHES

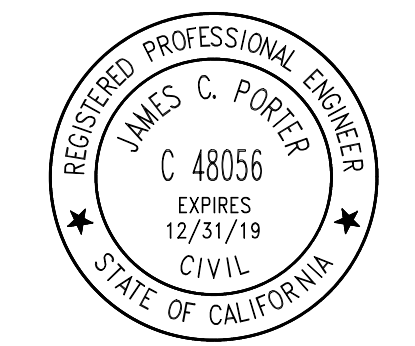

APPROVED: _____
 DATE: _____
 JAMES C. PORTER, DIRECTOR OF PUBLIC WORKS
 R. C. E. # 48056 / EXPIRES 12-31-2019

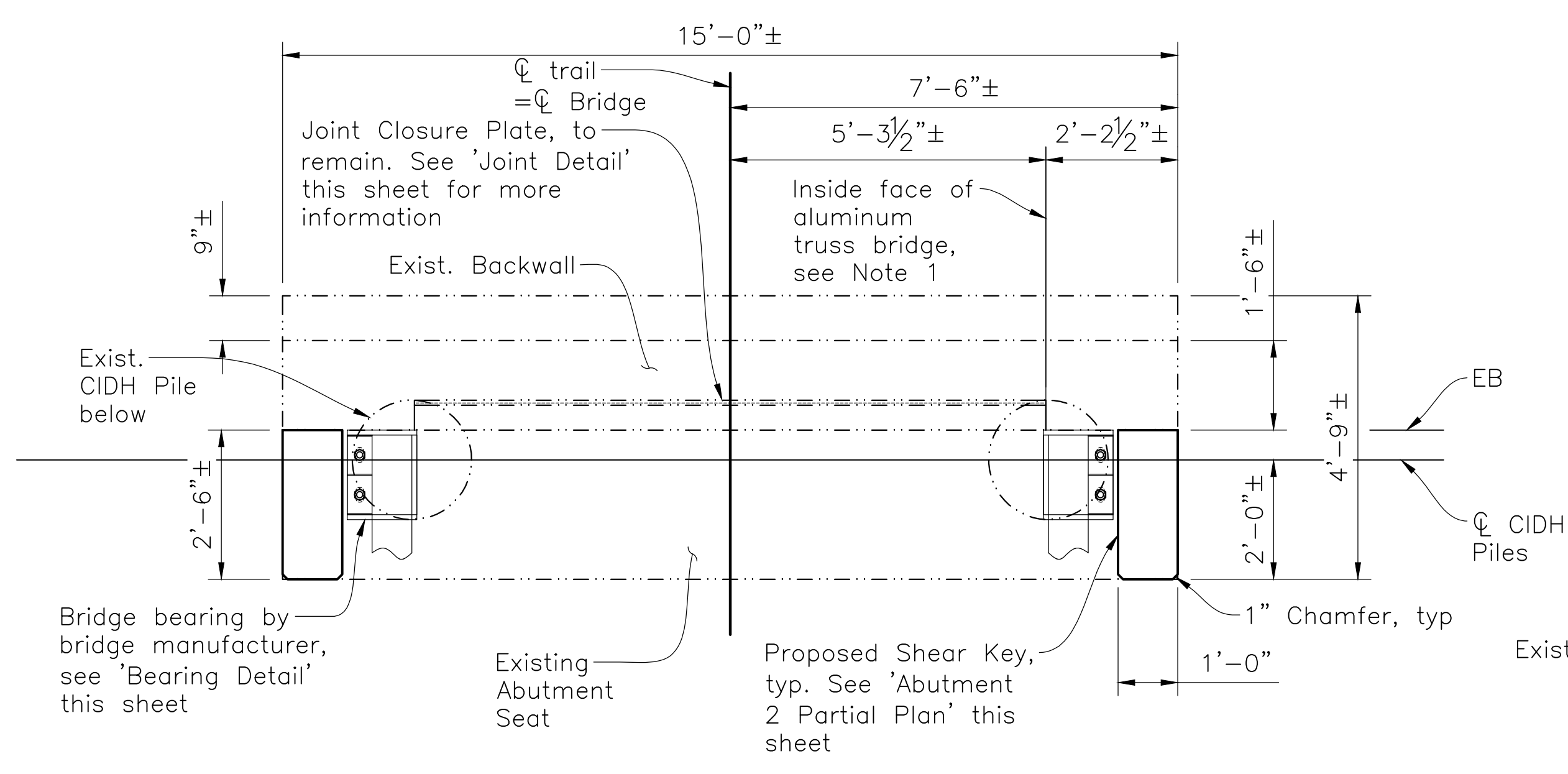

ABUTMENT 2 PLAN
 1/2"=1'-0"

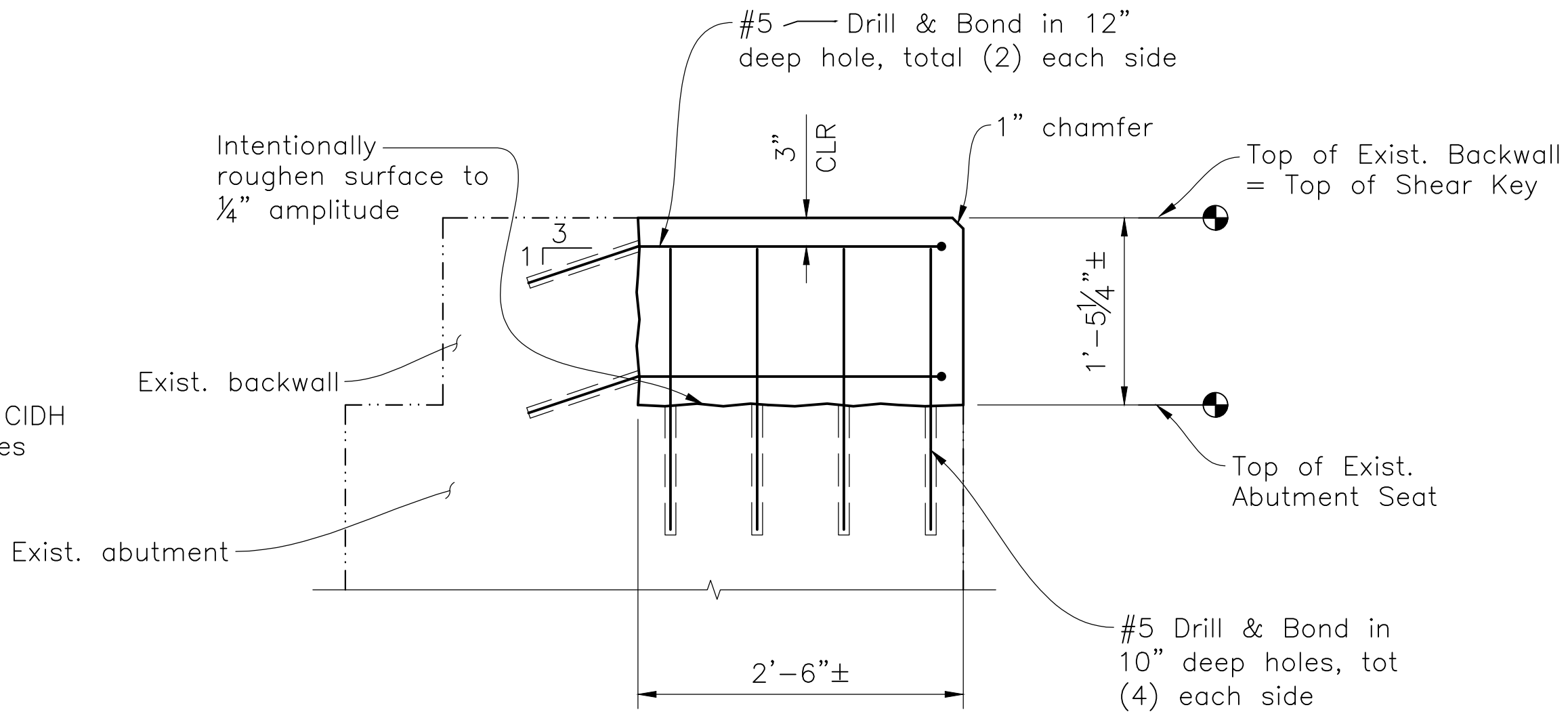

SECTION A
 1"=1'-0"

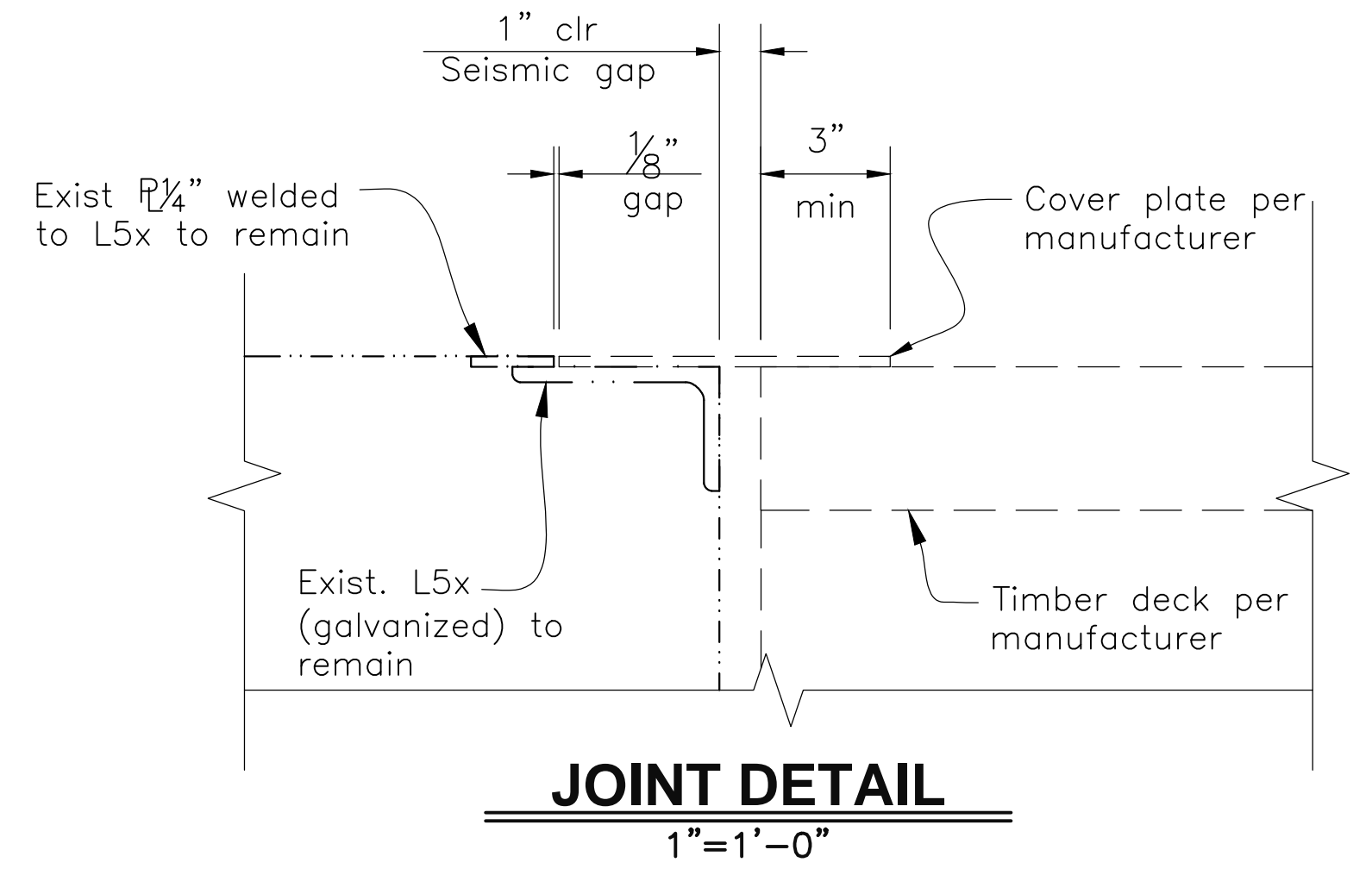

JOINT DETAIL
 1"=1'-0"

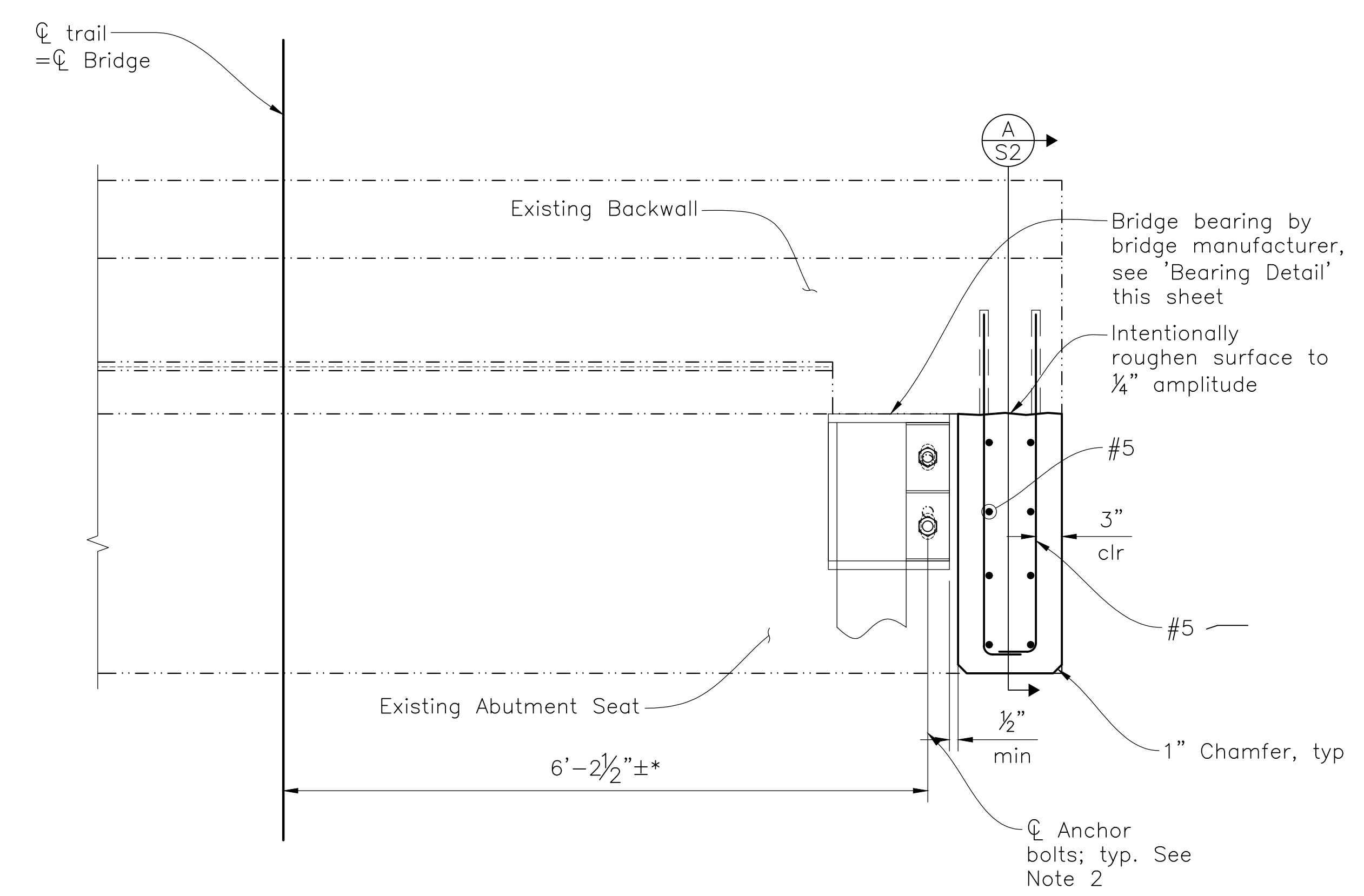

ABUTMENT 2 PARTIAL PLAN
 1"=1'-0"

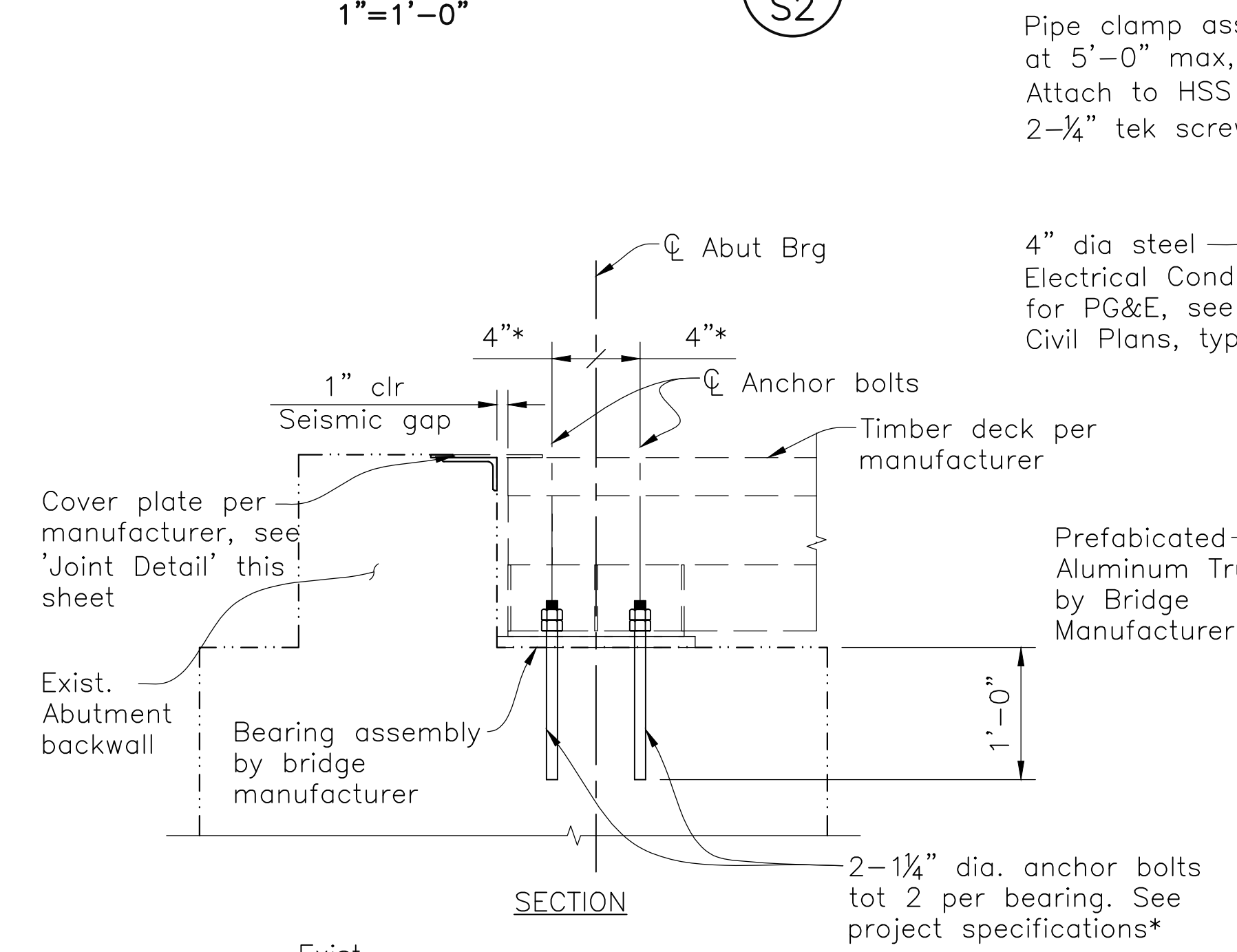

SECTION
 1"=1'-0"

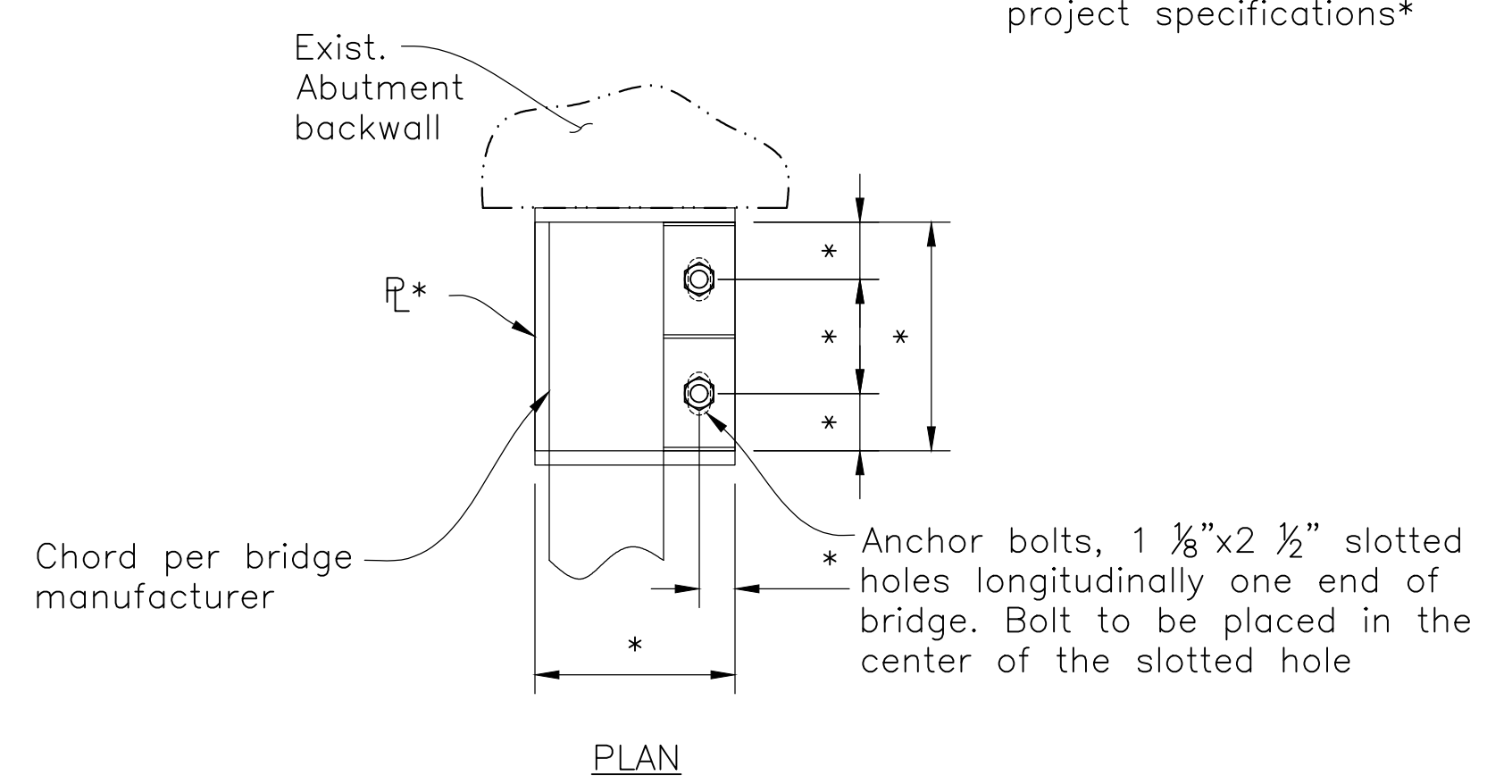

BEARING DETAIL
 1"=1'-0"

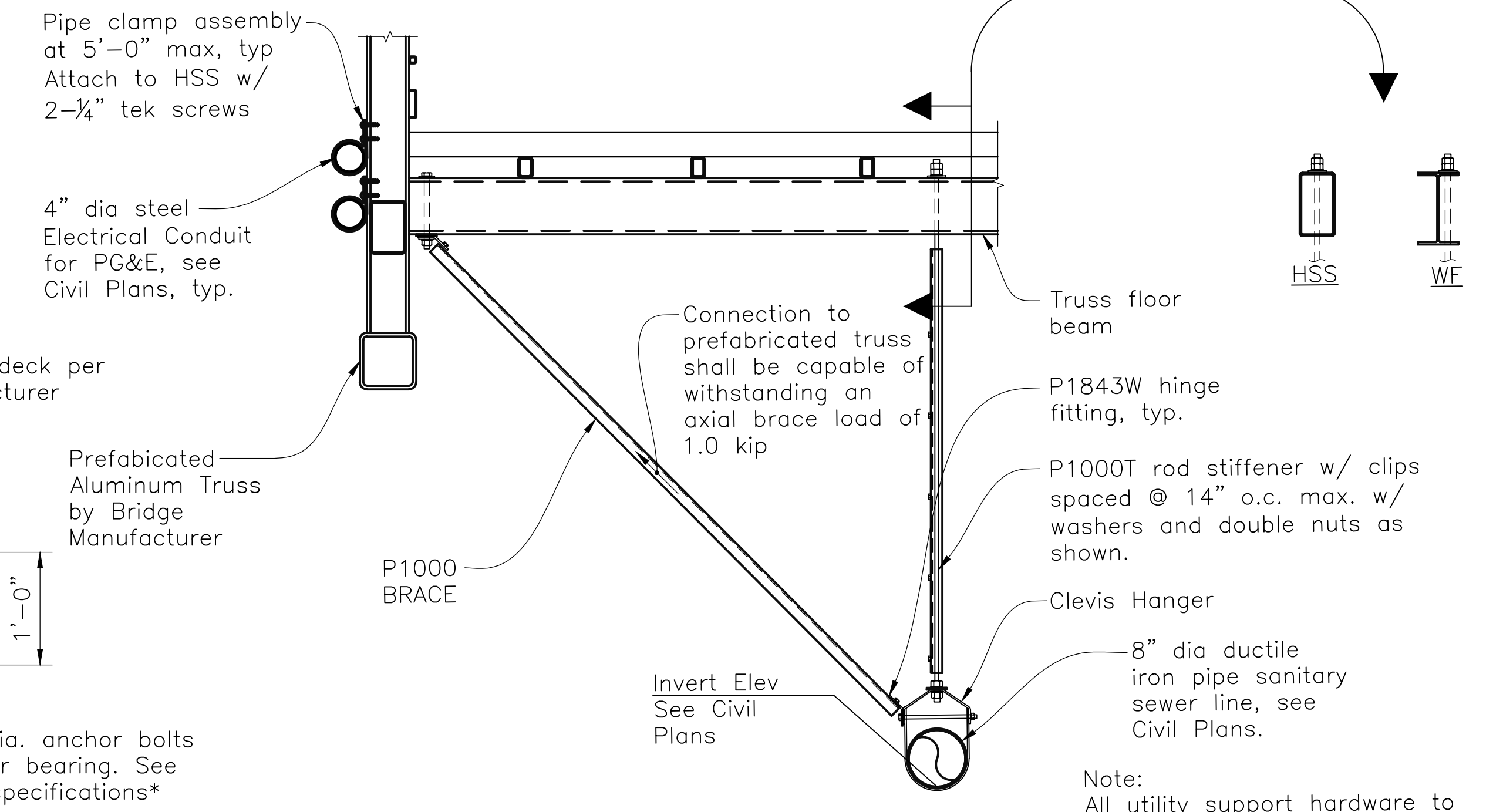

UTILITY SUPPORT DETAIL 1
 3/4"=1'-0"

Note:
 All utility support hardware to be stainless steel. See project specifications.

* Verify with bridge manufacturer (applies to all details)

Notes:
 1. Contractor to confirm all existing dimensions prior to any installation or construction.
 2. Verify all Aluminum Truss Bridge dimensions with the bridge manufacturer.
 3. Existing abutment reinforcement not shown for clarity.
 4. Contractor to confirm layout of shear key based on prefabricated bridge dimensions prior to placing shear keys.

65% SUBMITTAL
 JAN. 16, 2020
 NOT FOR CONSTRUCTION

APPROVED DATE:	
NAME NAME, CITY ENGINEER	
HALF MOON BAY	
R.C.E. # 00000 / EXPIRES 00-00-0000	

APPROVED DATE:	
NARCISO R. ZERMENO, S.E.	
CORNERSTONE STRUCTURAL ENGINEERING GROUP	
R.S.E. # S6783 / EXPIRES 3-31-2020	

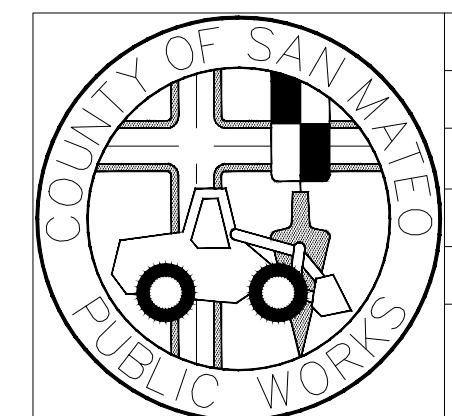
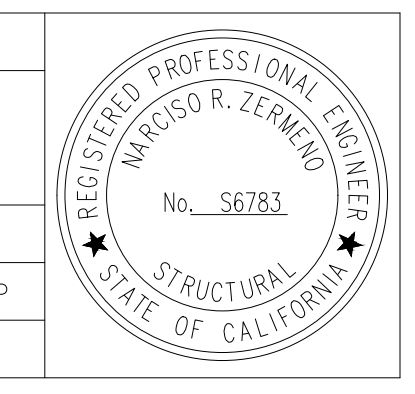

DESIGNED BY: NRZ	ABUTMENT DETAILS	SCALE: AS SHOWN
CHECKED BY: -		DATE: 01/16/2020
DRAWN BY: TLW	MIRADA ROAD	FILE NO.: 4122700
JAMES C. PORTER, DIRECTOR OF PUBLIC WORKS	SAN MATEO COUNTY	555 COUNTY CENTER, 5th FLOOR REDWOOD CITY, CALIFORNIA 94063
REVISION	DATE	
FOR REDUCED PLANS ORIGINAL SCALE IS IN INCHES		0 1 2 3 4
		S2 SHEET 12 OF 12

W:\2018\2018054-Mirada Road\Production\Bridges\01805452 - Abutment Details.dwg 01/16/2020 - 11:20 AM ehtl 13,3602