



County of San Mateo - Planning and Building Department

ATTACHMENT B



Source: Google Earth Pro, 2009.



047-312-040
047-311-060

Zoning Map

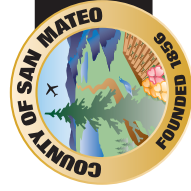

County of San Mateo - Planning and Building Department

ATTACHMENT C

NO.	DESCRIPTION	DATE

MAILED AND ASSOCIATES
 CIVIL ENGINEERING - LAND SURVEYING
 965 CENTER STREET - SAN CARLOS - CA 94070 - (650) 593-8580

PREPARED FOR:
 BIG WAVE LLC

VESTING TENTATIVE PARCEL MAP
 BEING A SUBDIVISION OF A.P.N. 047-312-040
 BIG WAVE WELLNESS CENTER
 AIRPORT STREET
 SAN MATEO COUNTY
 CALIFORNIA

DRAWN BY: JAP
 CHECKED BY: WMS
 DATE: 09/17/20
 SHEET: 1554-00
 SHEET: C-1

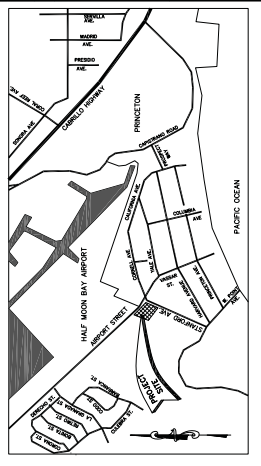

LOCATION MAP
 SCALE: NOT TO SCALE

RECORD OWNER AND SUBDIVIDER
 BIG WAVE LLC
 965 CENTER STREET
 SAN CARLOS, CA 94070

LAND SURVEYOR AND CIVIL ENGINEER
 MAILED & ASSOCIATES
 965 CENTER STREET
 SAN CARLOS, CA 94070
 (650) 593-8580

ASSESSOR'S PARCEL NUMBER
 047-312-040

EXISTING ZONING
 M/OF - LIGHT INDUSTRIAL WITH DESIGN REVIEW

UTILITIES
 W/OF - LIGHT INDUSTRIAL WITH DESIGN REVIEW

FLOOD ZONE
 - C -

UTILITY NOTE
 THE UTILITIES SHOWN ON THE SURFACE AND SHOWN ON THIS DRAWING HAVE BEEN OBTAINED FROM RECORDS OF THE VARIOUS UTILITY COMPANIES AND THE COMPLETENESS INDICATED LOCATION, DEPTH, SIZE, RECORD UTILITY LOCATION SHOULD BE CONFIRMED BY EXPOSING THE UTILITY.

- LEGEND:**
- CB CATCH BASIN
 - FF FINISHED FLOOR ELEVATION
 - FL FINISHED PAVEMENT
 - FL FLOWLINE
 - TC TOP OF CURB
 - TO TOP OF GRADE
 - SDH STORM DRAIN MANHOLE
 - SSH SANITARY SEWER MANHOLE
 - INV. INVERT
 - CD. CENTERLINE
 - CB. CENTERLINE
 - EP. EDGE OF PAVEMENT
 - SS NEW SANITARY SEWER LINE
 - SD NEW STORM DRAIN LINE
 - G GAS LINE
 - E ELECTRIC LINE
 - W WATER LINE
 - WELL WATER
 - REC RECYCLED WATER
 - PV PRIVATE JOINT TRENCH
 - PJT PUBLIC JOINT TRENCH
 - RWD RAINWATER DRAIN FOR ROOF RUNOFF

PARKING NOTE
 TYPICAL PARKING STALL DIMENSIONS = 9' X 18'

TREE NOTE
 THERE ARE NO EXISTING TREES ON THE SUBJECT PROPERTY.



Attachment C



EASEMENT NOTE
 PRIVATE UTILITY EASEMENTS WILL BE RESERVED OVER EACH PARCEL FOR THE EXISTING UTILITY LINES SHOWN ON THESE PLANS. BUT WILL BE CONTINGENT AND DEDICATED DURING THE BUILDING PERMIT PROCESS.



REV.	DATE	DESCRIPTION

MALEOD AND ASSOCIATES
 CIVIL ENGINEERING - LAND SURVEYING
 965 CENTER STREET - SAN CARLOS - CA 94070 - (650) 593-8590

PREPARED FOR:
BIG WAVE LLC

VESTING TENTATIVE SUBDIVISION MAP FOR COMMERCIAL
 CONDOMINIUM PURPOSES "BIG WAVE OFFICE PARK"
 BEING A SUBDIVISION OF A.P.N. 047-311-060
 SAN MATEO COUNTY
 CALIFORNIA

DATE: 11-14-07
 DRAWN BY: JMS
 CHECKED BY: DSM
 SCALE: 1" = 40'
 SHEET NO. 001
 OF 001



LOCATION MAP
 NOT TO SCALE

RECORD OWNER AND SUBDIVIDER:
 BIG WAVE LLC
 P.O. BOX 700
 BELMONT, CA 94002

LAND SURVEYOR AND CIVIL ENGINEER:
 MALEOD & ASSOCIATES
 965 CENTER STREET
 SAN CARLOS, CA 94070
 (650) 593-8590

ASSESSOR'S PARCEL NUMBER:
 047-311-060

EXHIBITING A PROPOSED ZONING:
 M-1/0R - LIGHT INDUSTRIAL WITH DESIGN REVIEW

UTILITIES:
 WATER MAIN: SAN MATEO COUNTY WATER DEPARTMENT
 SANITARY SEWER: GRANDVIEW SANITARY DISTRICT
 GAS: CALIFORNIA GAS COMPANY
 TELEPHONE: SBC TELEPHONE
 FLOOD PROTECTION: HALF MOON BAY

FLOOD ZONE:
 F-1

UTILITY NOTE:
 THE UTILITIES EXISTING ON THE SURFACE AND SHOWN ON THIS DRAWING HAVE BEEN LOCATED BY FIELD SURVEY. ALL UNDERGROUND UTILITIES ARE SHOWN AS APPROXIMATE LOCATIONS. THE SURVEYOR ENGINEER DOES NOT ASSUME LIABILITY FOR THE LOCATION OR DEPTH OF UTILITIES. THE SIZE AND DEPTH OF UTILITIES SHOULD BE DETERMINED BY EXPOSING THE UTILITY.

LEGEND:

- CB CATCH BASIN
- FF FINISHED FLOOR ELEVATION
- PP FINISHED PAVEMENT
- TOURNEAU
- FL FLOOR FINISH
- TC TOP OF CURB
- TC TOP OF GRADE
- SMWH STORM DRAIN MANHOLE
- SMWH SANITARY SEWER MANHOLE
- INV. INVERT
- H.P. HIGH POINT
- GB GRADE BREAK
- JP JOINT POINT
- EP EDGE OF PAVEMENT
- NSW NEW SANITARY SEWER LINE
- NSD NEW STORM DRAIN LINE
- G GAS LINE
- E ELECTRIC LINE
- W WATER LINE
- NC NEW CONTOUR LINE

PARCEL 2 (69 PM 21-22)
 APN 047-300-060
 LANDS OF BUCKS BUTANE
 PROPANE BVCS INC.

TEMPORARY BENCHMARK:
 BENCH MARK 274.46
 SAN MATEO COUNTY DATUM

PARKING NOTE:
 TYPICAL PARKING STALL DIMENSIONS = 9' X 20'
 TYPICAL HANDICAP PARKING STALL DIMENSIONS = 9' X 20' WITH 8' WIDE BAYS
 UNLOADING AREA

TREE NOTE:
 THESE ARE NO EXISTING TREES ON THE SUBJECT PROPERTY.

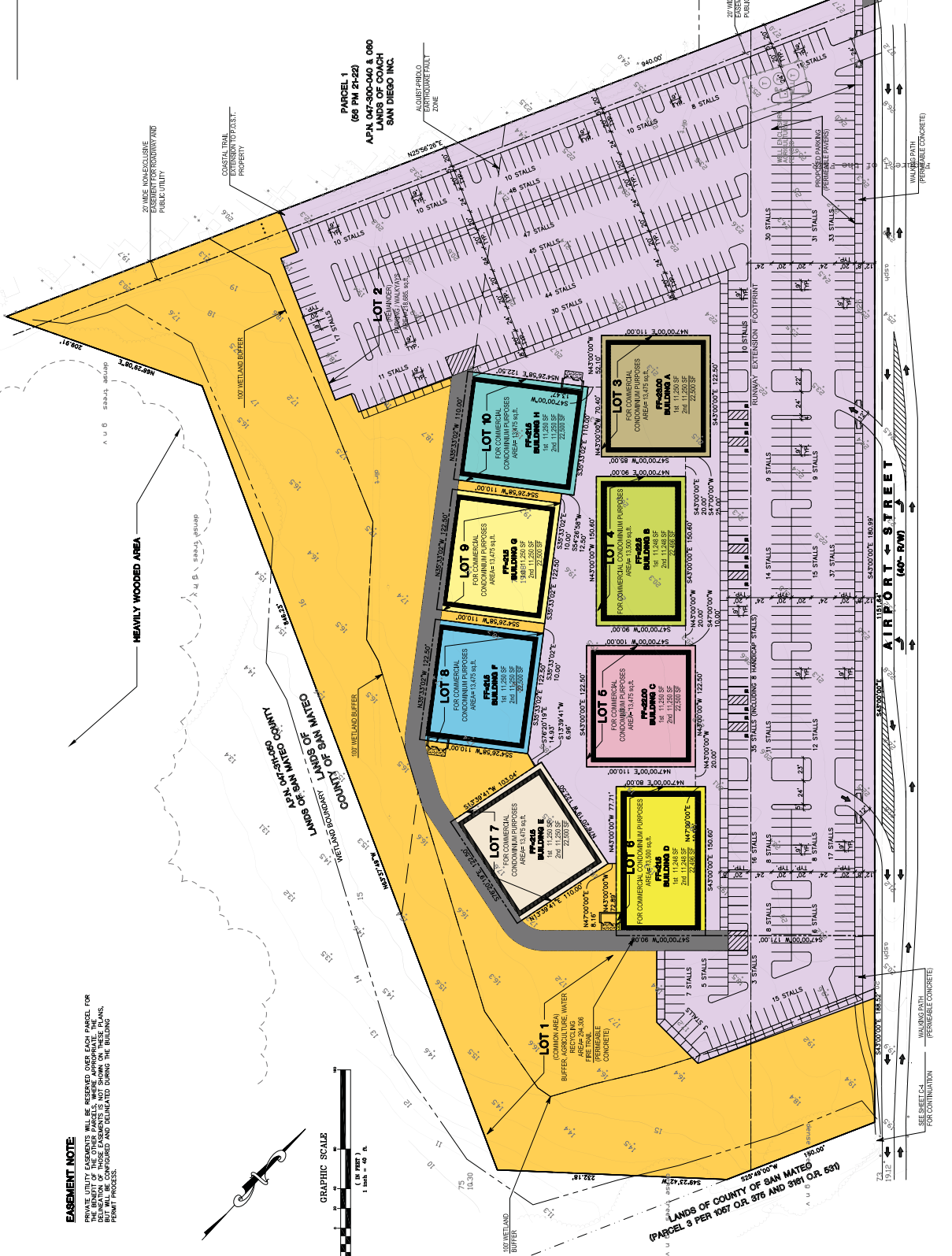

EASEMENT NOTE:
 PRIVATE UTILITY EASEMENTS WILL BE RESERVED OVER EACH PARCEL FOR THE INSTALLATION AND MAINTENANCE OF UTILITIES. THE EASEMENTS WILL BE SHOWN ON THESE PLANS, BUT WILL BE CONFIGURED AND DELINEATED DURING THE BUILDING PERMITS PROCESS.

GRAPHIC SCALE:
 1 inch = 40 feet

LANDS OF COUNTY OF SAN MATEO (PARCEL 9 PER 1067 O.R. 876 AND 8161 O.R. 639)



County of San Mateo - Planning and Building Department

ATTACHMENT D

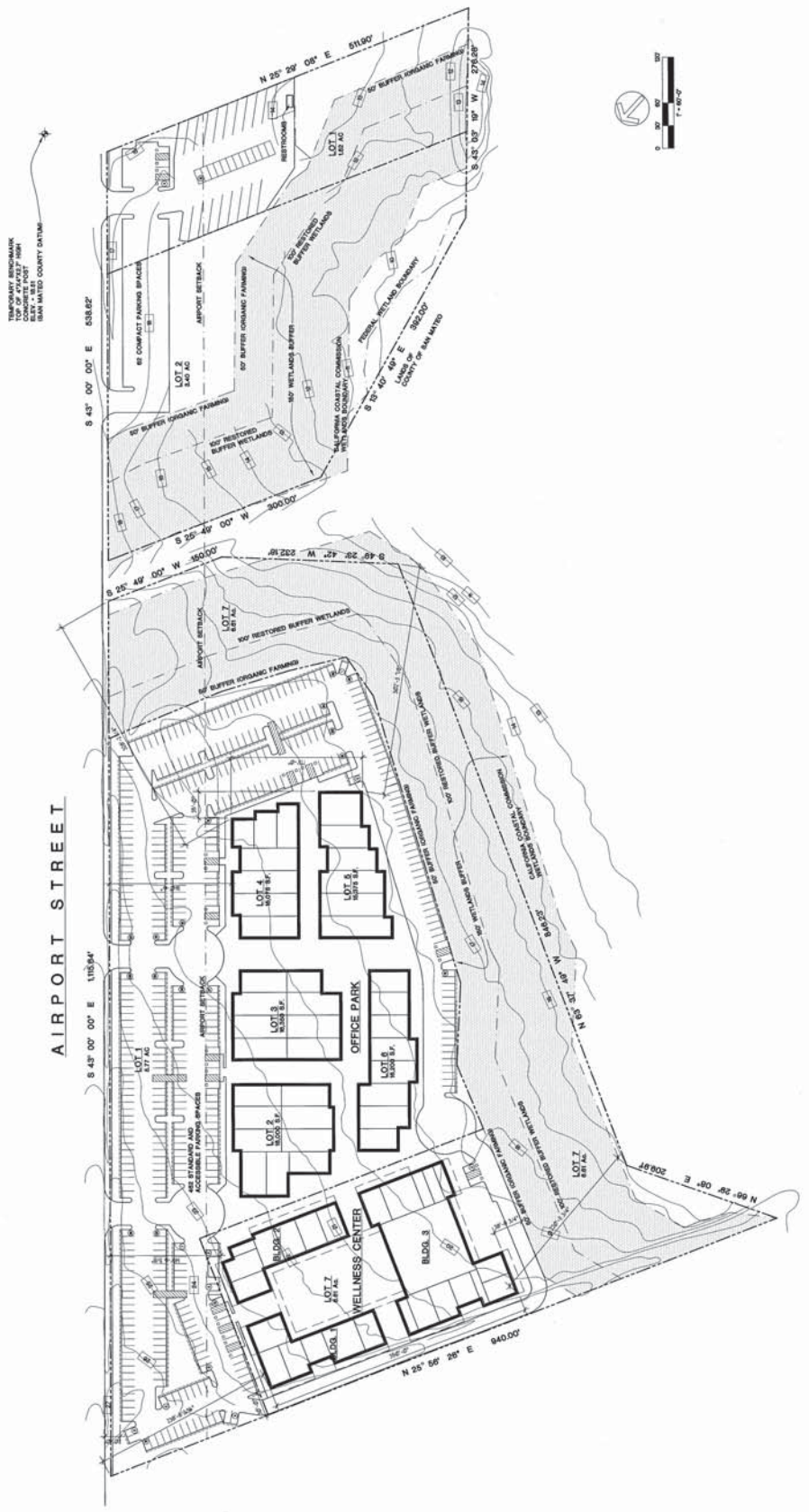

TEMPORARY MECHANICAL
TOP OF FINISHED FLOOR
ELEVATION
SAN MATEO COUNTY CENTER



Attachment D



DATE: 11-11-2014
 DRAWN BY: J. GONZALEZ
 CHECKED BY: J. GONZALEZ

PROPOSED DEVELOPMENT FOR
BIG WAVE
 WELLNESS CENTER AND OFFICE PARK
 VESTING TENTATIVE MAP FOR RESIDENTIAL WELLS CENTER AND
 COMMERCIAL, COMMUNITY PURPOSES BIG WAVE BUSINESS PARK
 (VERSION SHEET TO 6-30-2014 VESTING TENTATIVE MAP)

DATE: 11-11-2014
 DRAWN BY: J. GONZALEZ
 CHECKED BY: J. GONZALEZ

**VESTING TENTATIVE MAP
 SITE PLAN**

C-1

SCALE: 1" = 100'-0"
 SHEET NO. 1 OF 1
 DATE: 11-11-2014
 DRAWN BY: J. GONZALEZ
 CHECKED BY: J. GONZALEZ

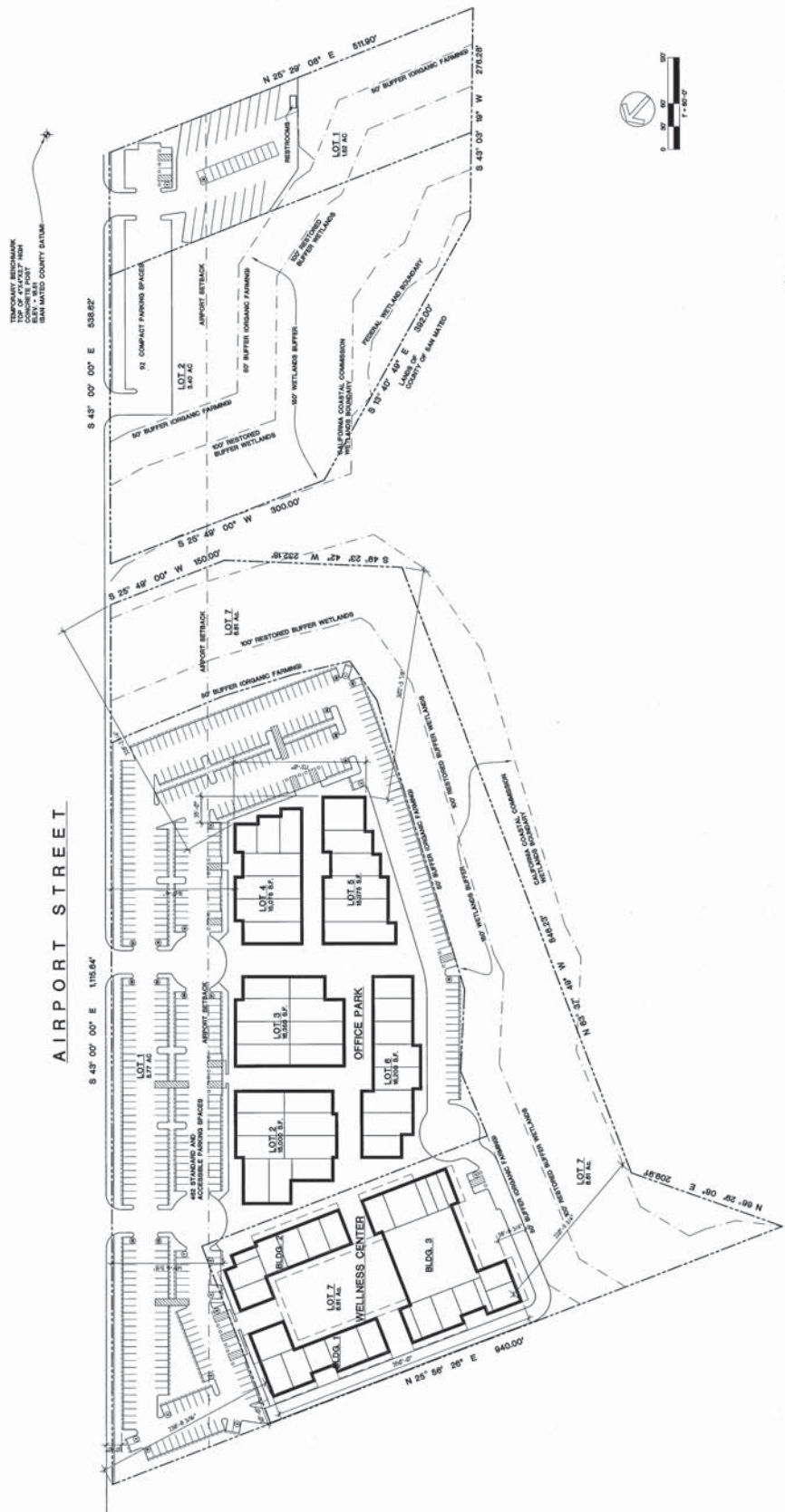

TEMPORARY MONUMENT
 TOP OF 4" DIAMETER IRON
 PIPE
 ELEV. = 88.1
 SAN MATEO COUNTY DATUM

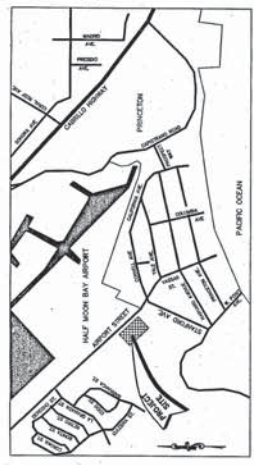

- LEGEND:**
- C COMPACT PAVING
 - EL ELEVATION
 - EP EDGE OF PAVEMENT
 - PH FIRE HYDRANT
 - SM SANITARY MANHOLE
 - SMH SANITARY MANHOLE
 - WY WATER VALVE
 - WM WATER METER
 - W GAS LINE
 - ELC ELECTRIC LINE
 - DM DOMESTIC WATER
 - SS SANITARY SEWER
 - SS-2 SANITARY SEWER
- PARKING NOTE:**
- TYPICAL STANDARD PAVING STALL DIMENSIONS = 9' X 15'
 - TYPICAL COMPACT PAVING STALL DIMENSIONS = 8' X 15'
 - TYPICAL HANDICAP PAVING STALL DIMENSIONS = 9' X 15' WITH 6" RISE UNLOADING AREA
 - TOTAL NUMBER OF PAVING STALLS = 554
 - 80% DESIGN SPEED FOR DRIVEWAYS, ENTRANCES AND EXITS
- UTILITY NOTE:**
- PACIFIC GAS AND ELECTRIC COMPANY
 - SANITARY SEWER
 - MOUNTAIN WATER AND LAND
 - TEL. PROTECTION
 - HALF MOON BAY
- FLOOD ZONE**
- * X * (FOR LETTER OF MAP AMENDMENT CASE NO. 08-09-0050A)

RECORD OWNER AND SUBDIVIDER:
 P.O. BOX 100
 REDWOOD CITY, CA 94062

LAND SURVEYOR AND CIVIL ENGINEER:
 J. GONZALEZ
 805 COCKER STREET
 SAN CARLOS, CA 94070
 (415) 352-0600

ASSESSOR'S PARCEL NUMBERS

EXISTING & PROPOSED ZONING

UTILITIES:

GRADING QUANTITIES

PARCEL	FILL (CY)	CUT (CY)
NORTH PARCEL	0	640
UTILITY TRENCHING:	15,000	0
GRAVEL MATERIAL	0	0
SOUTH PARCEL	0	2500
UTILITY TRENCHING	96	736
GRAVEL MATERIAL	0	0
TOTAL	15,000	3140

UTILITY NOTE:
 THE UTILITIES SHOWN ON THIS MAP ARE BASED ON THE RECORD MAPS AND SURVEYS. THE UTILITY LOCATIONS SHOWN ON THIS MAP ARE FROM RECORDS OF THE CITY OF SAN MATEO. THE CITY OF SAN MATEO DOES NOT ASSUME RESPONSIBILITY FOR THE ACCURACY OF THESE UTILITIES. THE UTILITY LOCATIONS SHOWN ON THIS MAP SHOULD BE CONFIRMED BY EXPOSING THE UTILITY.

EASEMENT NOTE:
 PRIVATE UTILITY EASEMENTS WILL BE RESERVED OVER EACH PARCELS. THE LOCATION OF THESE EASEMENTS IS NOT SHOWN ON THESE PLANS. THE UTILITY LOCATIONS SHOWN ON THESE PLANS SHOULD BE CONFIRMED DURING THE BUILDING PERMIT PROCESS.

TREE NOTE:
 THERE ARE NO EXISTING TREES ON THE SUBJECT PROPERTIES.



County of San Mateo - Planning and Building Department

ATTACHMENT E



PROPOSED DEVELOPMENT FOR
BIG WAVE
 WELLNESS CENTER AND OFFICE PARK

WESTLAND TREATMENT MAP FOR RESIDENTIAL, WELLNESS CENTER AND
 COMMERCIAL COMMONS IN PORTAGE BEACH BUSINESS PARK
 (REVISION SHEET TO THE 6-00-2004 WESTLAND TREATMENT MAP)

PORTION OF
 LOT 7

C-3

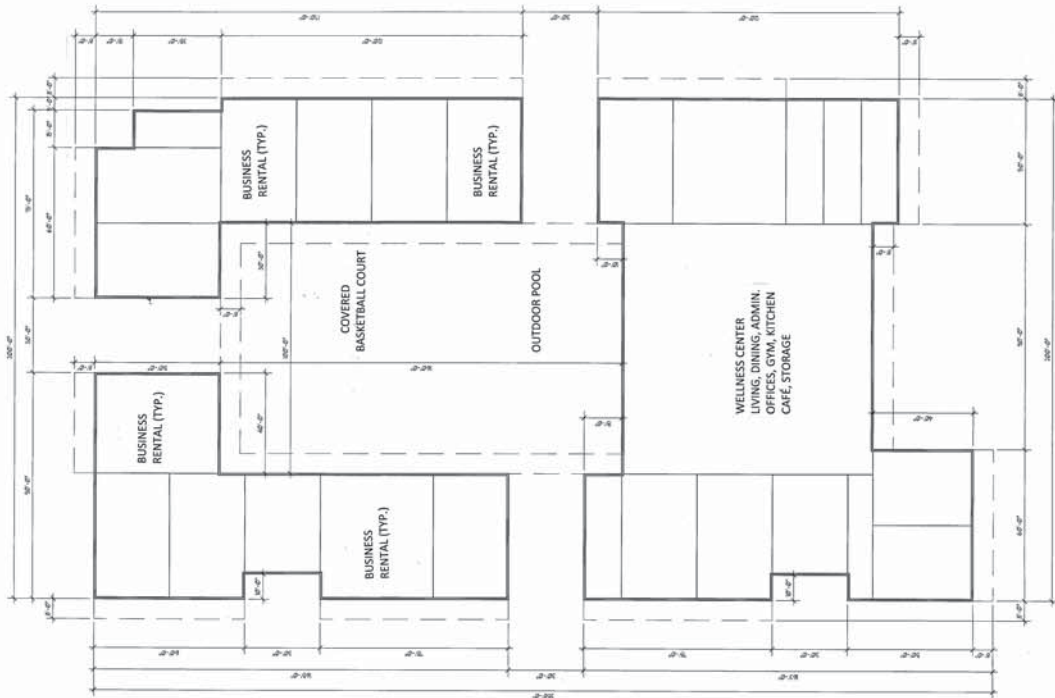

FIRST FLOOR
 (WELLNESS CENTER
 COMMUNITY ROOMS
 AND BUSINESS RENTALS)

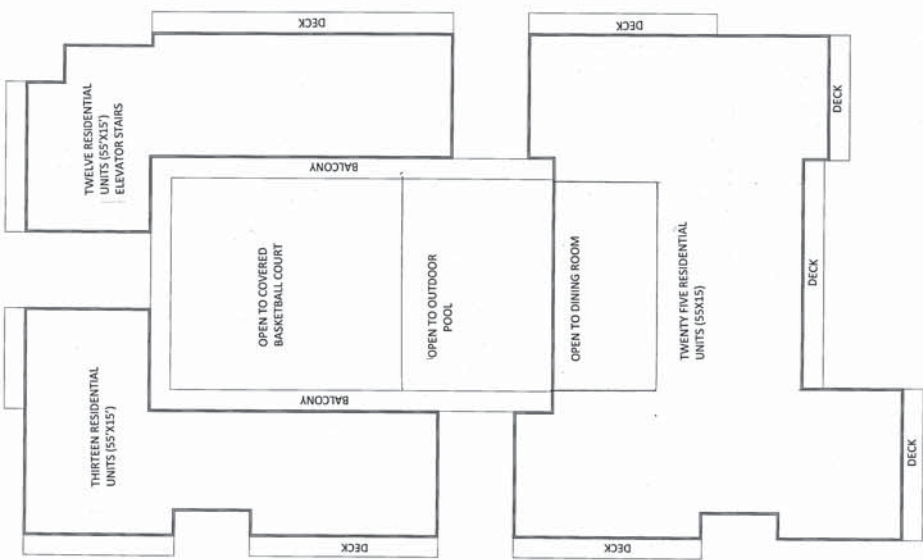

SECOND FLOOR
 (WELLNESS CENTER
 RESIDENTIAL UNITS)

Attachment E

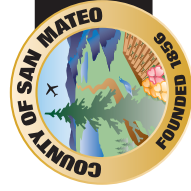

County of San Mateo - Planning and Building Department

ATTACHMENT F



DATE: 1-6-2014

PROPOSED DEVELOPMENT FOR
BIG WAVE
WELLNESS CENTER AND OFFICE PARK
VESTING TENTATIVE MAP FOR RESIDENTIAL BIG WAVE BUSINESS CENTER AND
COMMERCIAL CONDOMINIUM PURPOSES BIG WAVE BUSINESS CENTER AND
(VERSION SHEET TO THE 6-00-2014 VESTING TENTATIVE MAP)

DATE: 1-6-2014

LOTS
2, 3, 4, 5 AND 6

C-2

PLANNING DIVISION
150 SOUTH GAVIN AVENUE, SUITE 100
LOS ANGELES, CALIFORNIA 90012
TELEPHONE: (213) 475-3000
FAX: (213) 475-3001
WWW.CITYOFLOSANGELES.CA.GOV

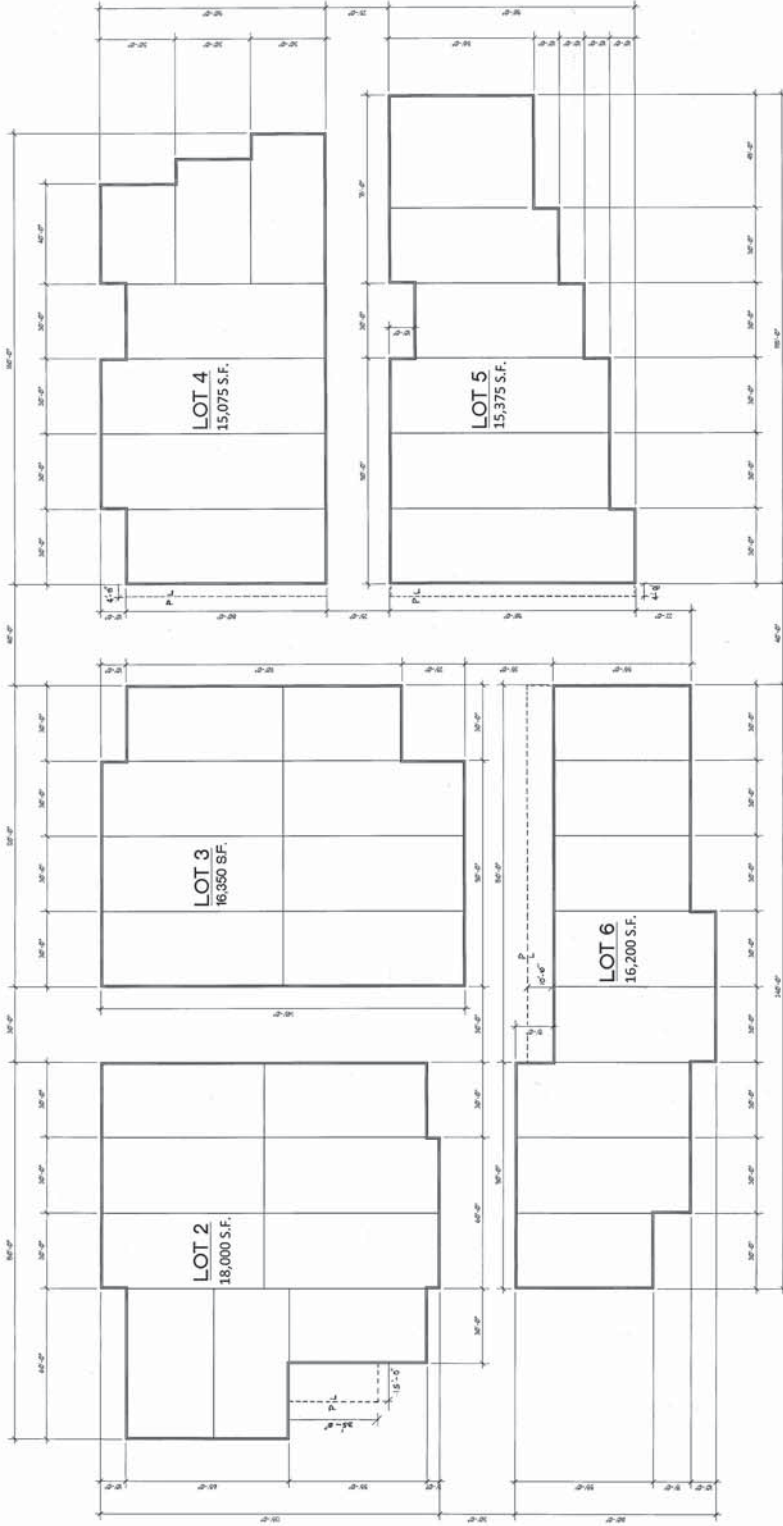

Attachment F

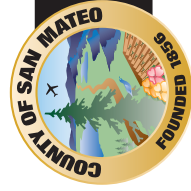

County of San Mateo - Planning and Building Department

ATTACHMENT G

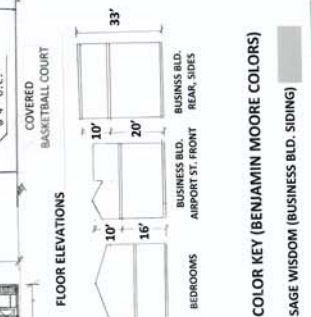
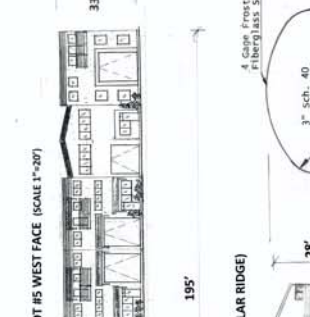
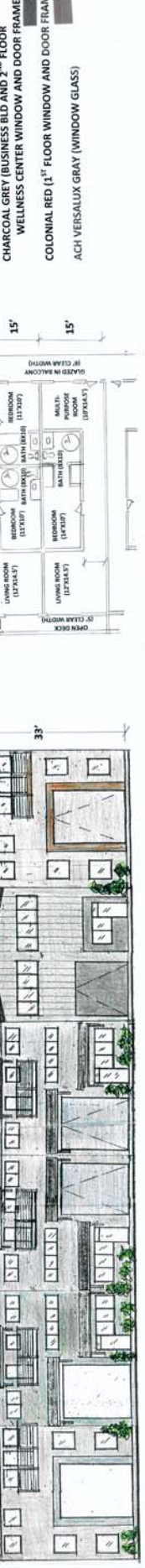



County of San Mateo - Planning and Building Department

ATTACHMENT H

AIRPORT STREET

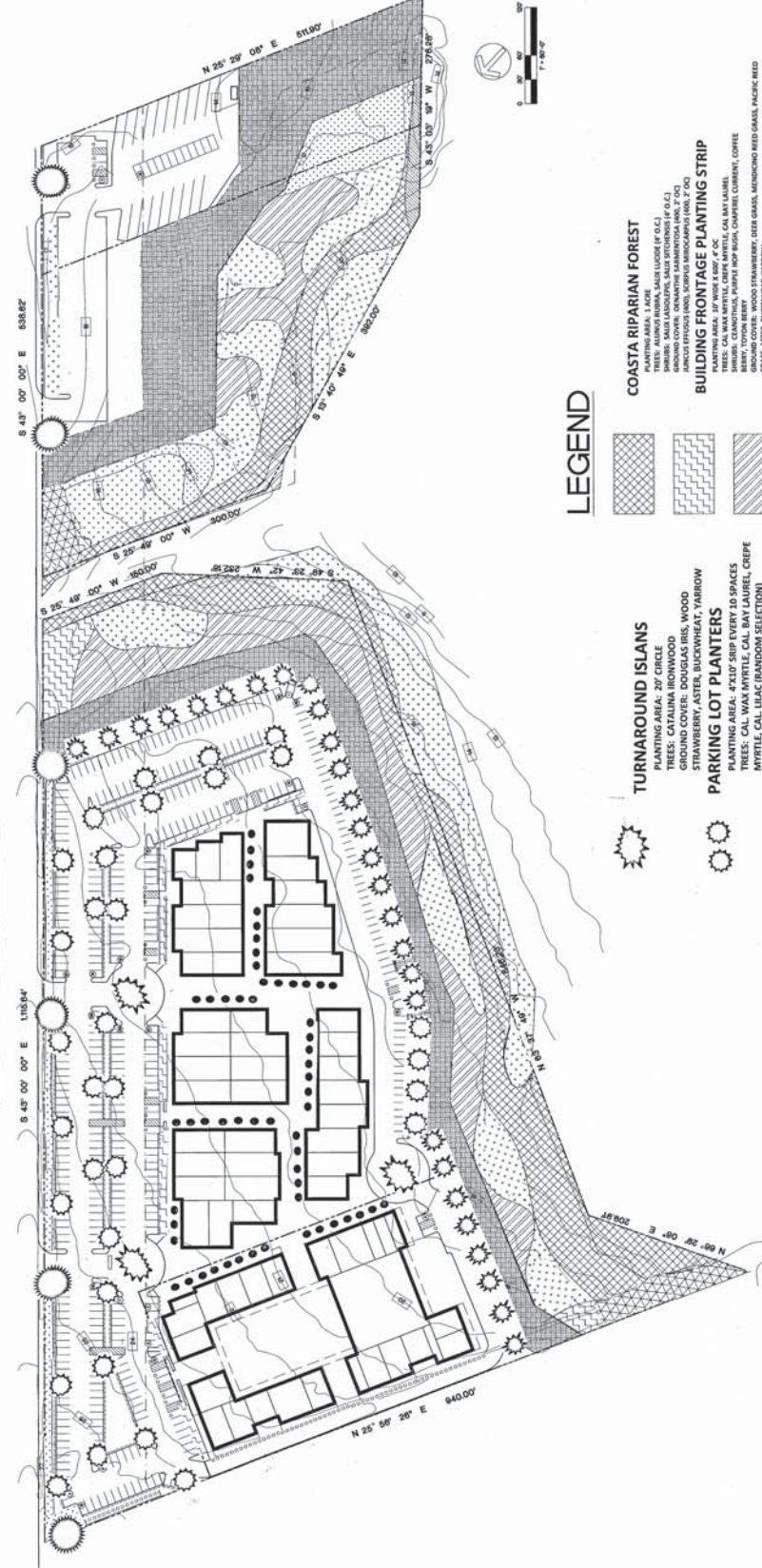

LEGEND

- TURNAROUND ISLANDS**
PLANTING AREA: 20' CIRCLE
TREES: CATALINA IRONWOOD
GROUND COVER: DOUGLAS IRIS, WOOD STRAWBERRY, ASTER, BUCKWHEAT, YARROW
- PARKING LOT PLANTERS**
PLANTING AREA: 4'X10' STRIP EVERY 10 SPACES
TREES: CAL WAX MYRTLE, CAL BAY LAUREL, CREPE MYRTLE, CAL LILAC (RANDOM SELECTION)
GROUND COVER: CAL WAX MYRTLE, DEER GRASS, DEER GRASS, ASTER, BUCKWHEAT, YARROW
- PARKING LOT ENTRANCES**
PLANTING AREA: 10'X12'
TREES: CAL WAX MYRTLE (SINGLE TREE)
GROUND COVER: CAL FESCUE, MENDOCINO REED GRASS, DEER GRASS, ASTER, BUCKWHEAT, YARROW
- PARKING LOT PERIMETER**
PLANTING AREA: 10'X14'
TREES: APPLE COASTAL FRUIT TREES
GROUND COVER: BERRIES, GLOBE ARITCHOKE, ORGANIC VEGETABLES
- COURTYARD PLANTERS**
PLANTING AREA: HALF WINE BARRELS, 200 RANDOM
SHRUBS: BLUEBERRY, TRELLISED MARIONBERRY, BLACKBERRY, GOOSEBERRY, ESPALIERED FRUIT
GROUND COVER: STRAWBERRY
- COASTA RIPARIAN FOREST**
PLANTING AREA: 1.4 ACRES
TREES: ALMOND BURMA, SAUER LUCIDE (E O.C.)
SHRUBS: CALIFORNIA SAGE, CALIFORNIA SAGE
GROUND COVER: DENNITTIA SAMANTHANA (M2, T O2)
ARCHITECTURAL TREES: SCORPUS MENDOCINUS (M2, T O2)
- BUILDING FRONTAGE PLANTING STRIP**
PLANTING AREA: 37' WIDE X 600' ± O.C.
TREES: CALIFORNIA SAGE, CALIFORNIA SAGE
SHRUBS: CANTONIA, PERRY, MOP BUSH, CAMPBELL, CURRY, COFFEE
GROUND COVER: WOOD STAMENBERRY, DEER GRASS, MENDOCINO REED GRASS, PACIFIC REED GRASS, ASTER, BUCKWHEAT, YARROW
- MIXED WILLOW SHRUB SCRUB**
PLANTING AREA: 0.3 ACRES (E O2)
TREES: CALIFORNIA SAGE, CALIFORNIA SAGE
SHRUBS: SALIX LASIOLEPS, OSMORHIZA TEXASORHIZA
GROUND COVER: DENNITTIA SAMANTHANA (M2, T O2)
- WILLOW WATTLE**
PLANTING AREA: 0.32 ACRES
TREES: CALIFORNIA SAGE, CALIFORNIA SAGE
SHRUBS: SALIX LASIOLEPS, OSMORHIZA TEXASORHIZA
GROUND COVER: DENNITTIA SAMANTHANA (M2, T O2)
- PILLAR RIDGE/WELLNESS CENTER PL. STRIP**
PLANTING AREA: 8' X 600' ± O.C.
TREES: CALIFORNIA SAGE, CALIFORNIA SAGE
GROUND COVER: WOOD STAMENBERRY, DEER GRASS, MENDOCINO REED GRASS, PACIFIC REED GRASS, ASTER, BUCKWHEAT, YARROW
- RUSH MEADOW/SEEDGE MEADOW**
PLANTING AREA: 1.0 ACRES
TREES: CALIFORNIA SAGE, CALIFORNIA SAGE
SHRUBS: JUNCUS MANTONII (M2), JUNCUS EFFUSUS (M2), JUNCUS PATENS (M2), SCORPUS MENDOCINUS (M2), POTENTILLA (M2)
- UPLAND FORREST**
PLANTING AREA: 0.3 ACRES
TREES: CALIFORNIA SAGE, CALIFORNIA SAGE
SHRUBS: BROWNEA CHARNOVITSI (M2), WIG DOUGLASSIANA (M2)
- AIRPORT STREET PLANTING STRIP**
PLANTING AREA: 27' WIDE X 600' ± O.C.
TREES: CALIFORNIA SAGE, CALIFORNIA SAGE
SHRUBS: CALIFORNIA SAGE, CALIFORNIA SAGE
GROUND COVER: WOOD STAMENBERRY, DEER GRASS, MENDOCINO REED GRASS, PACIFIC REED GRASS, ASTER, BUCKWHEAT, YARROW
- ORGANIC GARDEN**



County of San Mateo - Planning and Building Department

ATTACHMENT I

Attachment I

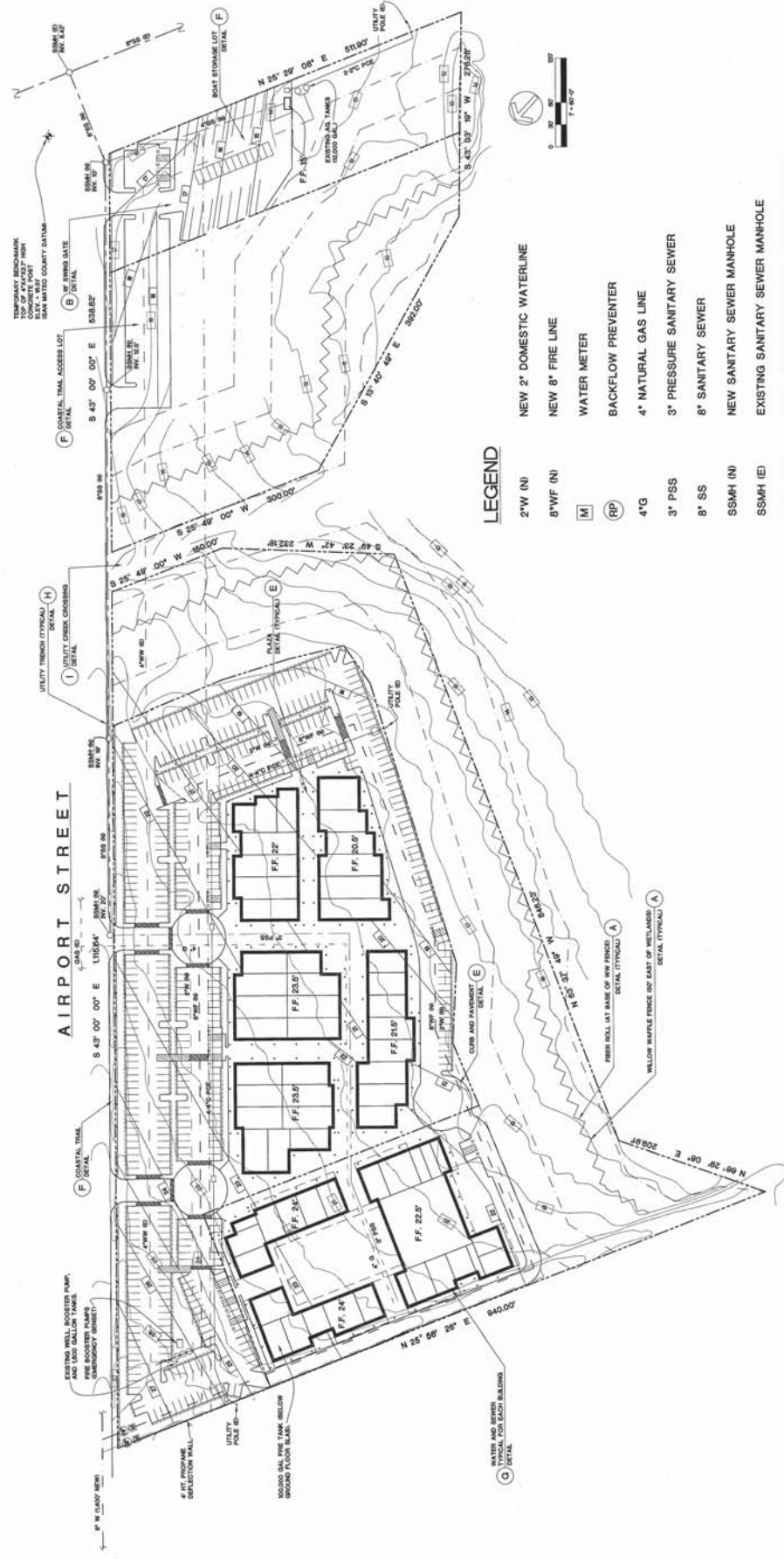

LEGEND

- 2"W (N)
- 8"W (N)
- [M] WATER METER
- [RP] BACKFLOW PREVENTER
- 4"G 4" NATURAL GAS LINE
- 3" PSS 3" PRESSURE SANITARY SEWER
- 8" SS 8" SANITARY SEWER
- SSMH (N) NEW SANITARY SEWER MANHOLE
- SSMH (E) EXISTING SANITARY SEWER MANHOLE
- 2-2"C PCE TWO - 2" CONDUITS, PHONE, CABLE, POWER
- 4-4"C PCE FOUR - 4" CONDUITS, PHONE, CABLE, POWER
- 18" NEW FINISH GRADE ELEVATION 18'
- 4"WW (E) 4" EXISTING WELL WATER LINE
- 18" EXISTING GRADE ELEVATION 17'
- PAVERS
- CROSSWALKS - WHITE PAVERS
- PLAZA - LIGHT BROWN PAVERS
- PARKING LOT - DARK GREY PAVERS
- PARKING LINE DELINEATION (4" WIDTH SAND WHITE PAVERS)
- 36" TALL DOWNCAST SS LIGHTING BOLLARDS (40W LAMPS AT 30' ON CENTER SPACING AROUND ALL BUILDINGS AND ALONG WALKWAYS)



CIVIL DETAILS
C-4

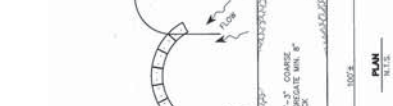
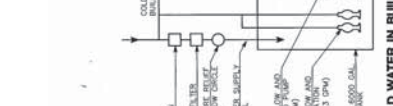

- GENERAL EROSION CONTROL NOTES:**
1. THE WATER QUALITY IMPACTS OF THE PROJECT SHALL BE MITIGATED BY THE INSTALLATION OF EROSION CONTROL MEASURES AS SHOWN ON THESE PLANS.
 2. ANY WATER QUALITY IMPACTS IN THE FORM OF SEDIMENT, EROSION, OR SLOPE FAILURE SHALL BE MITIGATED BY THE INSTALLATION OF EROSION CONTROL MEASURES AS SHOWN ON THESE PLANS.
 3. WHEN NECESSARY, WHEELS SHALL BE CLEANED TO REMOVE SEDIMENT FROM THE TIRE TREADS AND TRACKS OF ALL EQUIPMENT OPERATING ON THE SITE.
 4. WHEN NECESSARY, WHEELS SHALL BE CLEANED TO REMOVE SEDIMENT FROM THE TIRE TREADS AND TRACKS OF ALL EQUIPMENT OPERATING ON THE SITE.
 5. DURING THE RAINY SEASON, ALL PAVED AREAS SHALL BE KEPT CLEAN AND FREE OF DEBRIS AND SEDIMENT. SEDIMENT SHALL BE REMOVED AS IT ACCUMULATES ON THE PAVED AREAS.
 6. THE INSTALLATION OF EROSION CONTROL MEASURES SHALL BE IN ACCORDANCE WITH THE EROSION AND SEDIMENT CONTROL MANUAL, 4TH EDITION, 2002, QUALITY CONSTRUCTION.
 7. INSTALL TEMPORARY EROSION CONTROL OVER DISTURBED AREAS USING SWAMP MULCH.

INSTALLER SHALL:
 1. INSTALL EROSION CONTROL MEASURES AS SHOWN ON THESE PLANS.
 2. MAINTAIN EROSION CONTROL MEASURES IN GOOD WORKING ORDER THROUGHOUT THE CONSTRUCTION PERIOD.
 3. REMOVE AND REPAIR EROSION CONTROL MEASURES AS NECESSARY.
 4. MAINTAIN EROSION CONTROL MEASURES IN GOOD WORKING ORDER THROUGHOUT THE CONSTRUCTION PERIOD.
 5. REMOVE AND REPAIR EROSION CONTROL MEASURES AS NECESSARY.

INSTALLER SHALL:
 1. INSTALL EROSION CONTROL MEASURES AS SHOWN ON THESE PLANS.
 2. MAINTAIN EROSION CONTROL MEASURES IN GOOD WORKING ORDER THROUGHOUT THE CONSTRUCTION PERIOD.
 3. REMOVE AND REPAIR EROSION CONTROL MEASURES AS NECESSARY.
 4. MAINTAIN EROSION CONTROL MEASURES IN GOOD WORKING ORDER THROUGHOUT THE CONSTRUCTION PERIOD.
 5. REMOVE AND REPAIR EROSION CONTROL MEASURES AS NECESSARY.

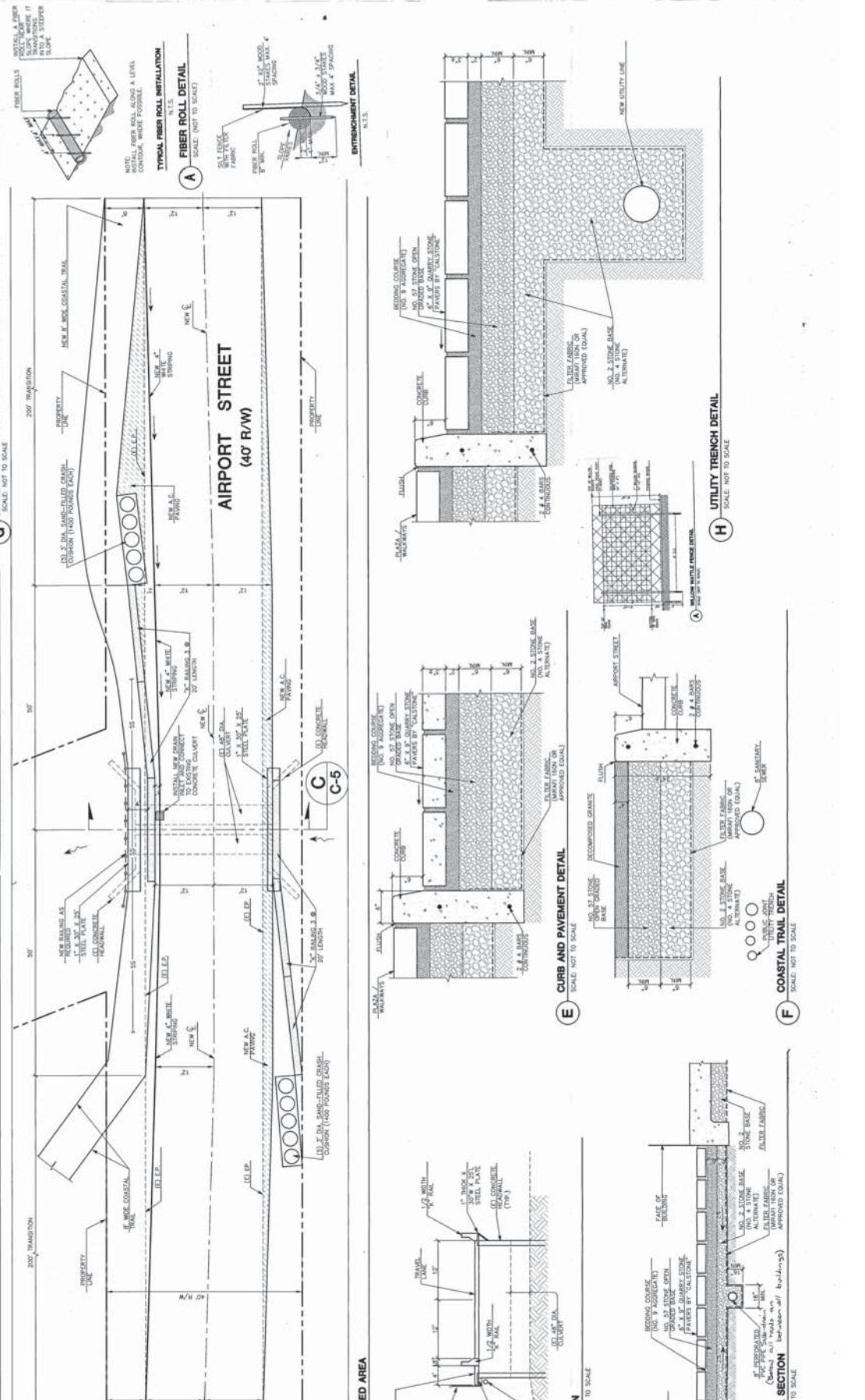

INSTALLER SHALL:
 1. INSTALL EROSION CONTROL MEASURES AS SHOWN ON THESE PLANS.
 2. MAINTAIN EROSION CONTROL MEASURES IN GOOD WORKING ORDER THROUGHOUT THE CONSTRUCTION PERIOD.
 3. REMOVE AND REPAIR EROSION CONTROL MEASURES AS NECESSARY.
 4. MAINTAIN EROSION CONTROL MEASURES IN GOOD WORKING ORDER THROUGHOUT THE CONSTRUCTION PERIOD.
 5. REMOVE AND REPAIR EROSION CONTROL MEASURES AS NECESSARY.

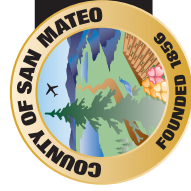

County of San Mateo - Planning and Building Department

ATTACHMENT J

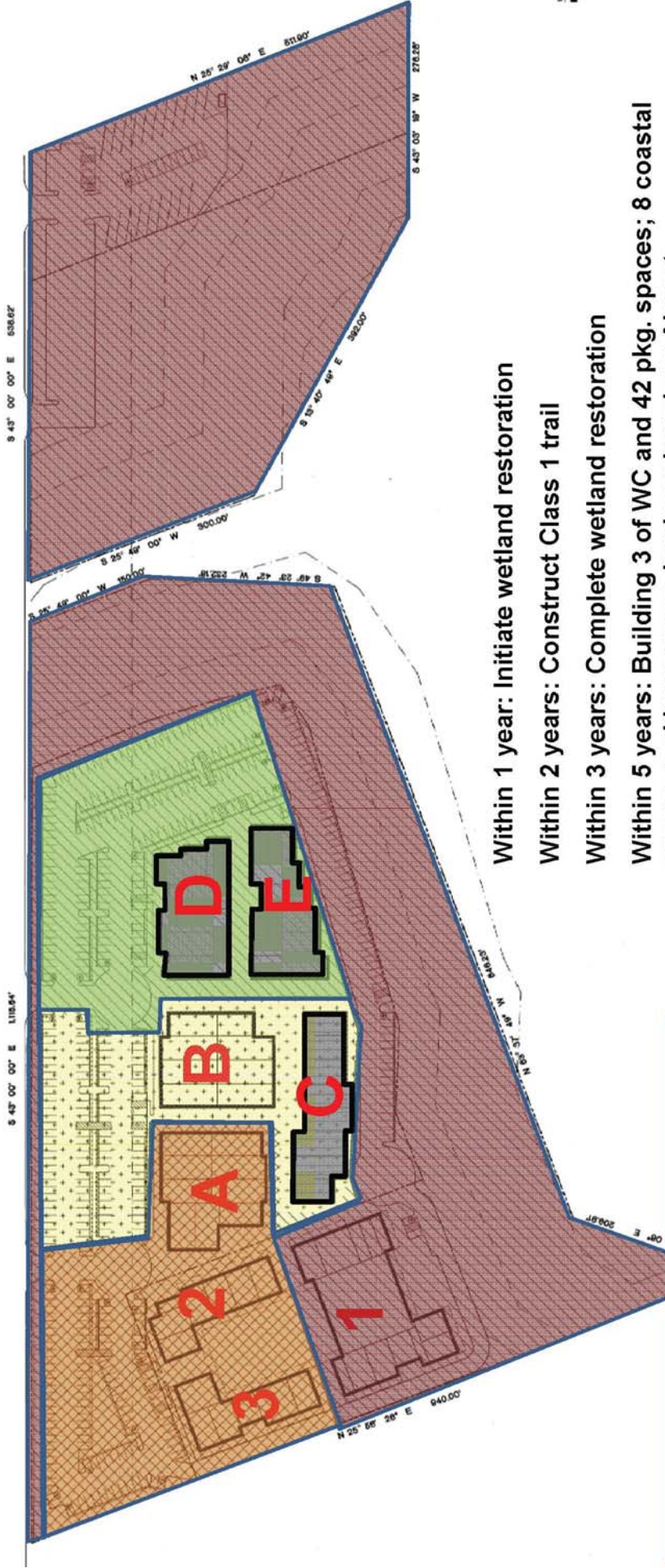

Within 1 year: Initiate wetland restoration

Within 2 years: Construct Class 1 trail

Within 3 years: Complete wetland restoration

Within 5 years: Building 3 of WC and 42 pkg. spaces; 8 coastal access parking spaces, landscaping along Airport

Within 12 years: Complete Wellness Center (must be prior to Office Park Bldgs. 4, 5, and 6)

Within 15 years: Complete project

Order of Building Construction

Color areas (in rainbow order) show area to be developed along with corresponding building

San Mateo County Planning Commission Meeting

Owner/Applicant: Big Wave LLC, Big Wave Group

File Numbers: PLN2013-00451

Attachment J



County of San Mateo - Planning and Building Department

ATTACHMENT K

AIRPORT STREET

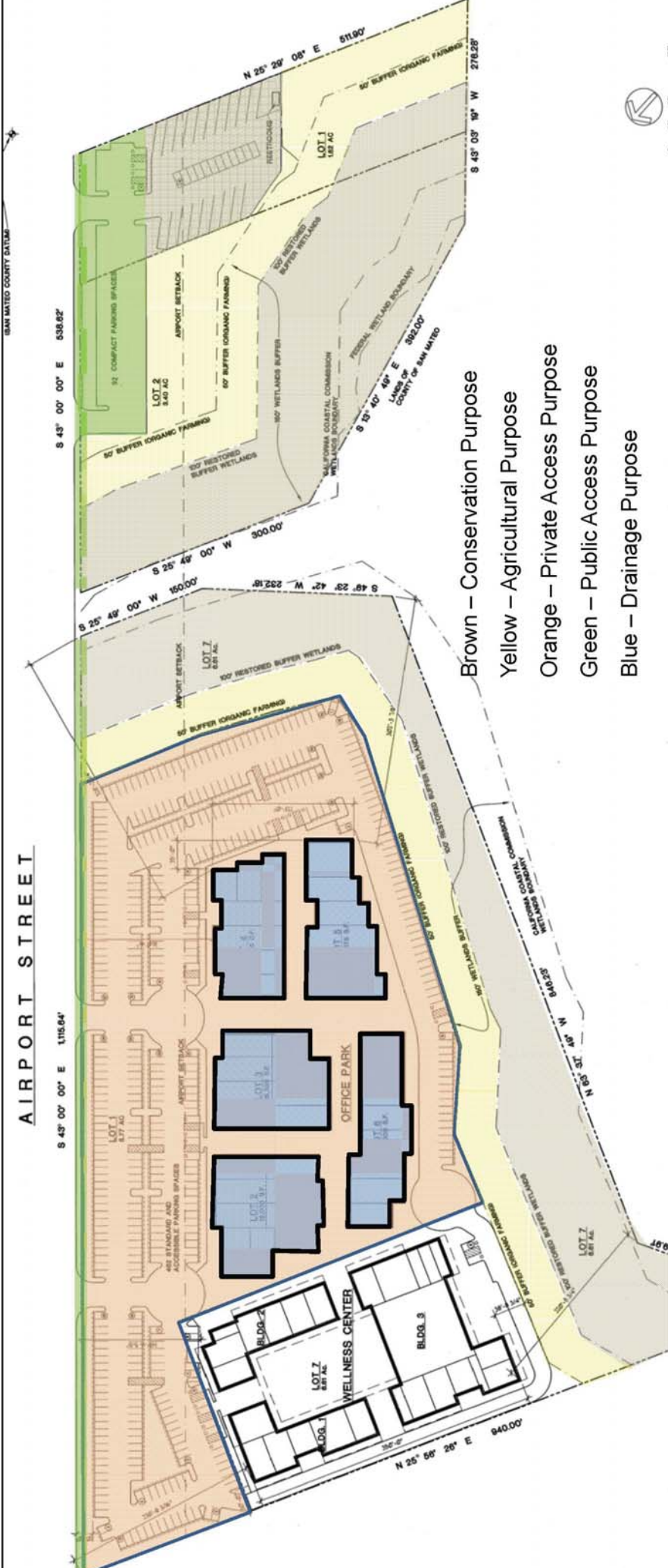

- Brown – Conservation Purpose
- Yellow – Agricultural Purpose
- Orange – Private Access Purpose
- Green – Public Access Purpose
- Blue – Drainage Purpose



County of San Mateo - Planning and Building Department

ATTACHMENT L

Attachment L

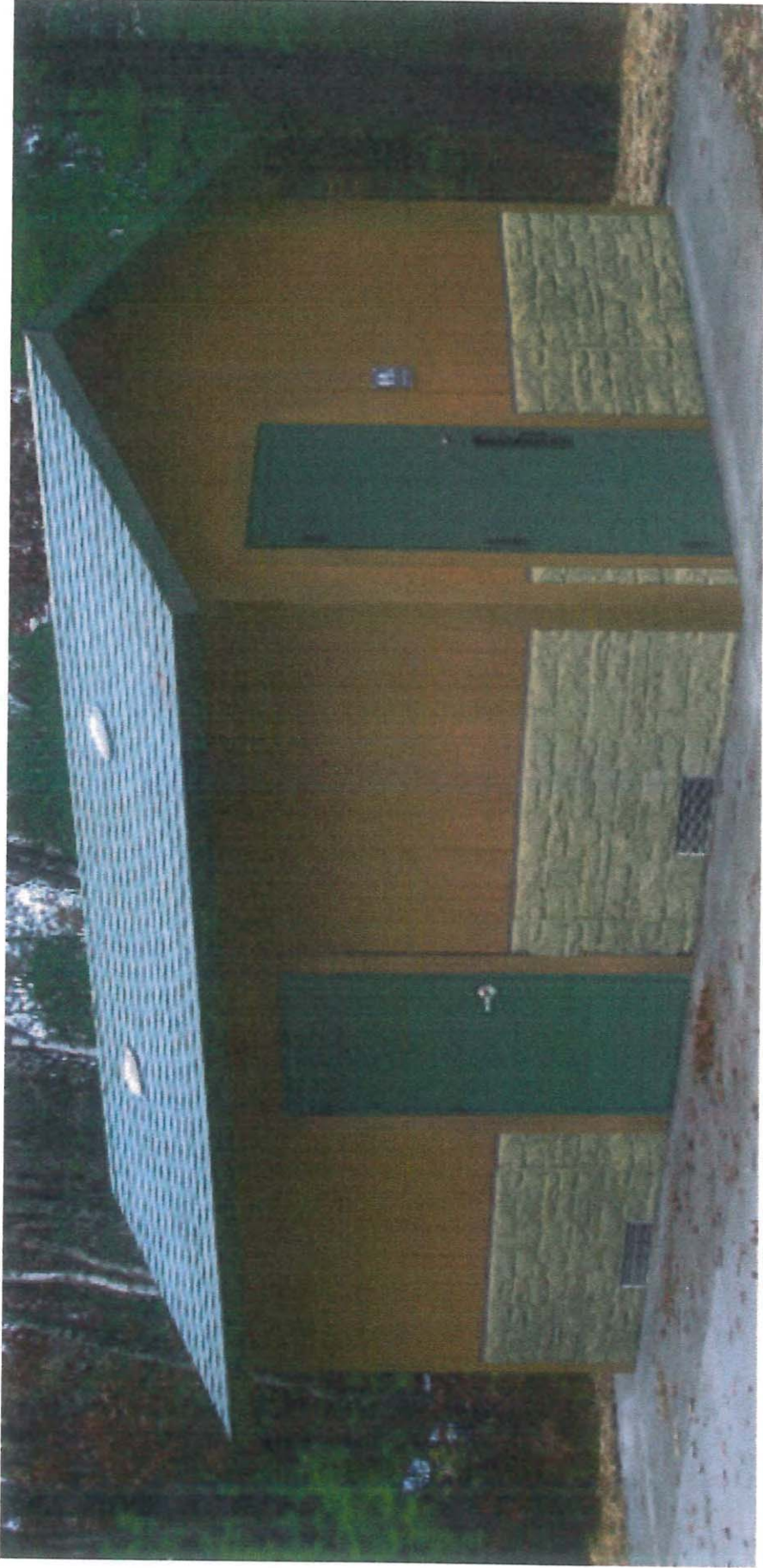

Precast/Preassembled Reinforced Concrete Bathroom

N.P.C.A. CERTIFIED PLANT
 MEMBER OF:
 NATIONAL & WISCONSIN PRECAST CONCRETE ASSOCIATIONS

THIS DRAWING SHALL NOT
 BE COPIED OR SUBMITTED
 TO OTHERS WITHOUT THE
 CONSENT OF THIS COMPANY.

4154 123rd STREET
 CHIPPEWA FALLS, WI 54729
 (715) 723-7446 ■ (800) 924-1516
 FAX (715) 723-7111 ■ WWW.HUFFCUTT.COM

HUFFCUTT
 CONCRETE, INC



PROJECT:
 RR200
 BUILDING

1 of 2

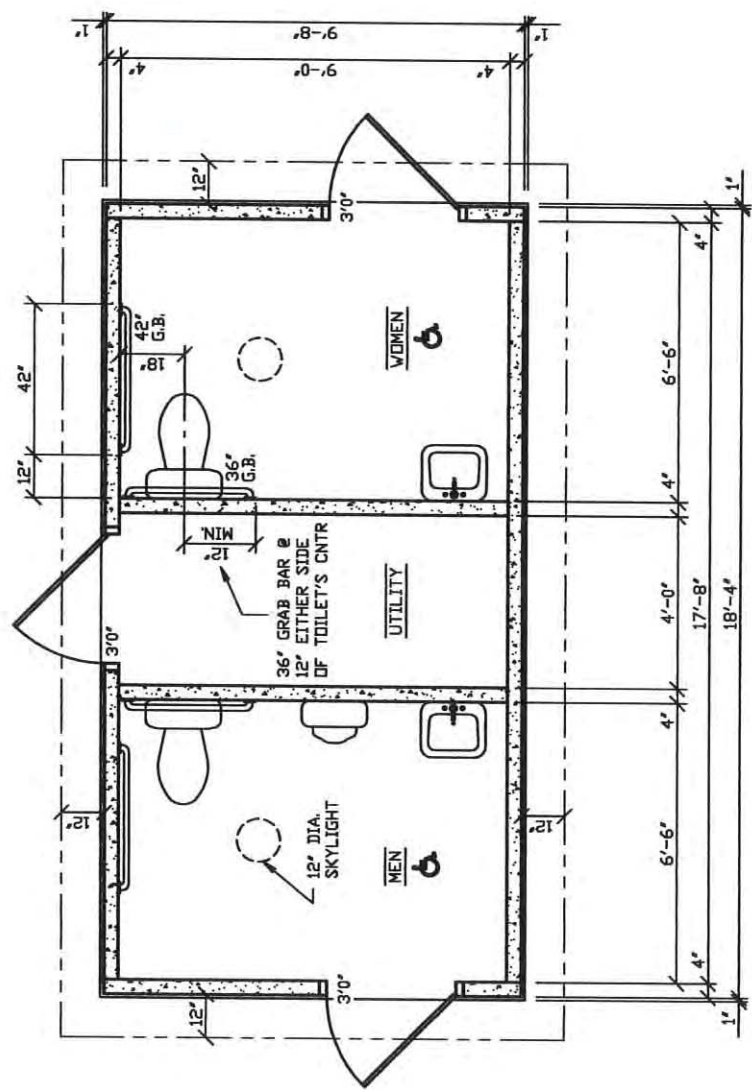

FLOOR PLAN
 SCALE: 1/4" = 1'-0"



HUFFCUT CONCRETE, INC.

4154 123rd STREET
CHIPPENVA FALLS, VI 54729
(715) 723-7446 # (800) 924-1516
FAX (715) 723-7111 # www.huffcutt.com

THIS DRAWING SHALL NOT BE COPIED OR REPRODUCED IN ANY MANNER WITHOUT THE WRITTEN CONSENT OF THIS COMPANY.

N.P.C.A. CERTIFIED PLANT & MEMBER OF: NATIONAL & WISCONSIN PRECAST CONCRETE ASSOCIATIONS

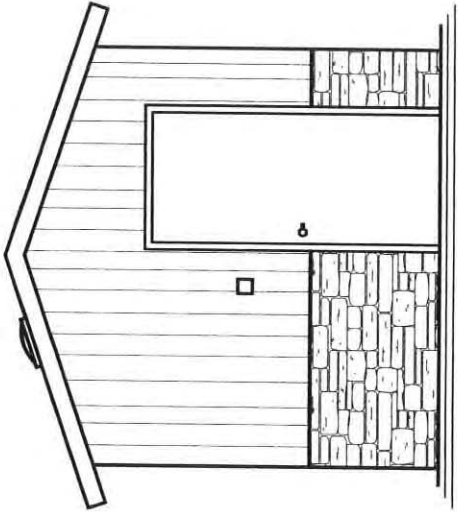

LEFT ELEVATION
SCALE: 1/4" = 1'-0"

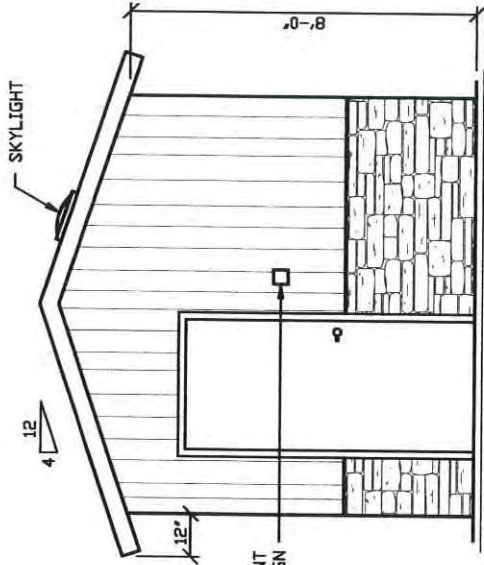

RIGHT ELEVATION
SCALE: 1/4" = 1'-0"

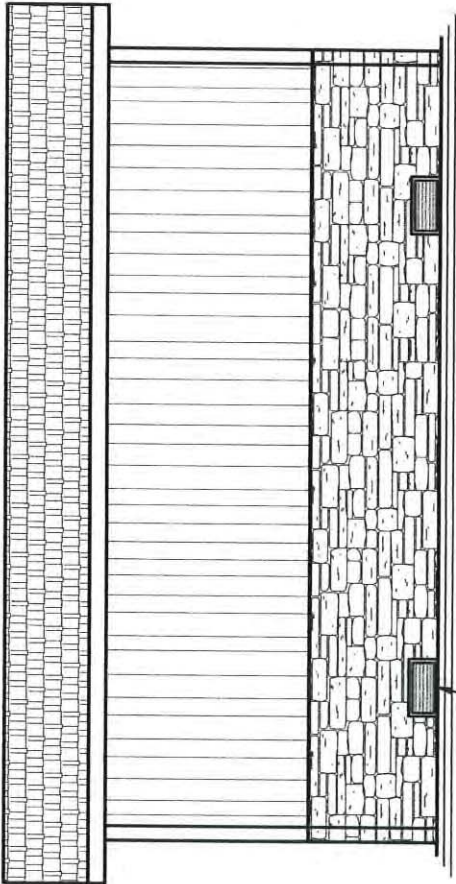

FRONT ELEVATION
SCALE: 1/4" = 1'-0"

5" CONCRETE ROOF PANELS WITH CEDAR SHAKE SHINGLE APPEARANCE

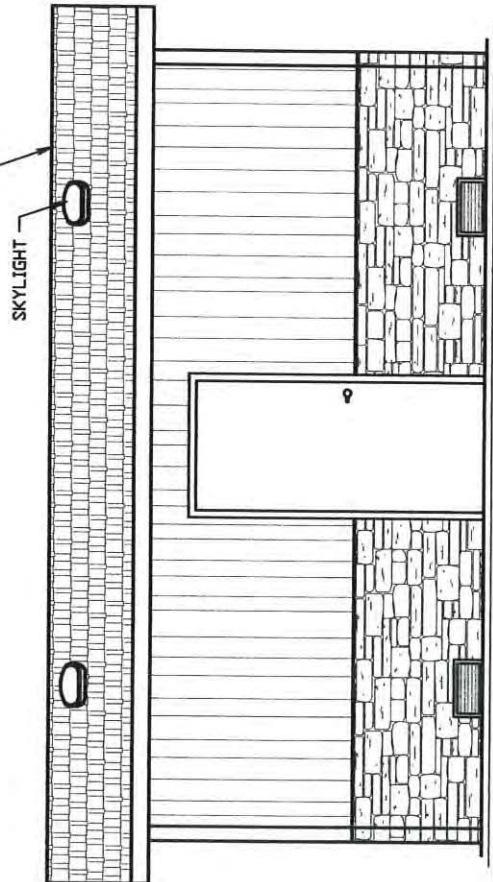

REAR ELEVATION
SCALE: 1/4" = 1'-0"

16" x 8" CAST ALUMINUM VENT

SKYLIGHT

ADA COMPLIANT RESTROOM SIGN

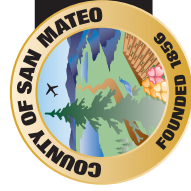

County of San Mateo - Planning and Building Department

ATTACHMENT M

DESCRIPTION

Bollards are designed for walkways, entranceways, drives and other small-area lighting applications where low mounting heights are desirable.

Catalog #		Type
Project		
Comments		Date
Prepared by		

SPECIFICATION FEATURES

Construction

TOP: Rugged, minimum 5/32" thick cast aluminum top cap secured via a concealed stainless steel allen screw with twist removal mechanism for lamp access. Flow through ventilation assure cool to the touch top. **LOUVERS:** Cast aluminum louver blades provide sharp cutoff delivering no direct light above 90°. Louvers are secured to the shaft via tamper stainless steel rods and fasteners. **LOWER HOUSING:** Nominal 1/8" thick aluminum extruded housing. Bollard housing is secured to the base with flathead, counter-sunk screws for smooth, uncluttered appearance. **BASE:** Rugged cast aluminum. Completely concealed.

Electrical

BALLAST: HID high power factor ballast for -20°F starting. Product is factory mounted to the base. Quick disconnects provided between lamp and electrical assembly. **LAMP:** Metal Halide and High Pressure Sodium lamp sources up to 100W.

Optical

One-piece tempered glass with internal flutes for even disbursement of illumination. Decorative colored glass optional. Globe is fully gasketed via EPDM material.

Mounting

Base mounts onto foundation with three (3) 1/2" x 12-1/2" anchor bolts on a 5" Dia. bolt circle (a centrally located 2-7/8" x 3 1/2" wire entrance opening provided).

Finish

Finished in weather- and abrasion-resistant polyester powder coat. Standard bronze finish. Other finishes available. Consult your Streetworks Representative.



LBS/LBR LOUVERED BOLLARD

35 - 100 W
High Pressure Sodium
Metal Halide

PATHWAY LUMINAIRE

DARK SKY COMPLIANT **CO**
Cutoff

DIMENSIONS

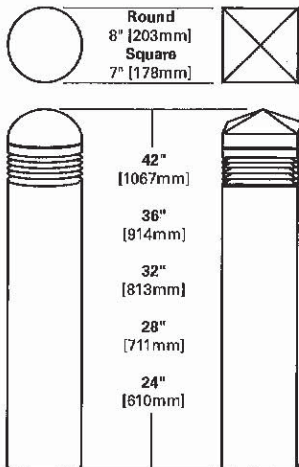

ANCHOR BOLT TEMPLATE (NOT TO SCALE)

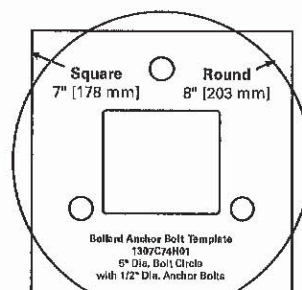

NOTE:
Conduit must be inside of opening with a maximum height of 2 1/4" above concrete.
Anchor bolt projection to be 1 1/2" minimum and 2 1/4" maximum above concrete.

SHIPPING DATA
Approximate Net Weight:
26 lbs. (2 kgs.)

COOPER LIGHTING

ADW100417



PHOTOMETRICS [Complete IES files available at www.cooperlighting.com]

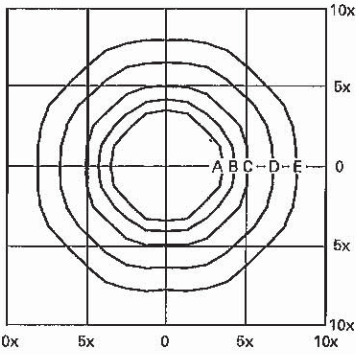

LBS10M11W36
100-Watt MH
7,900-Lumen Lamp (Coated ED-17)

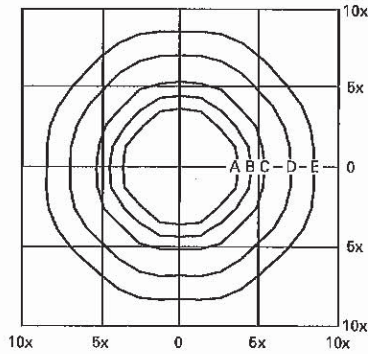

LBSLBS10S11W36
100-Watt HPS
8,800-Lumen Lamp (Coated ED-17)

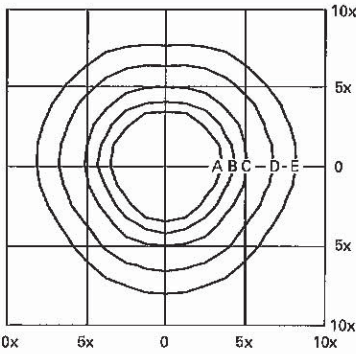

LBR10M11W36
100-Watt MH
7,900-Lumen Lamp (Coated ED-17)

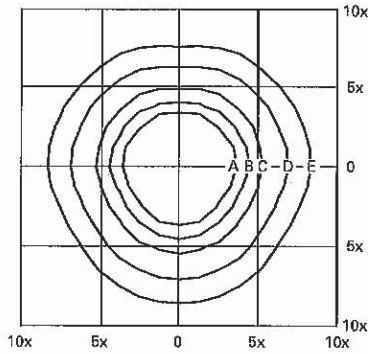

LBR10211W36
100-Watt HPS
8,800-Lumen Lamp (Coated ED-17)

Footcandle Table

Select mounting height and read across for footcandle values of each isofootcandle line. Distance in units of mounting height.

Mounting Height	Footcandle Values for Isofootcandle Lines				
	A	B	C	D	E
42"	1.20	0.60	0.30	0.12	0.06
36"	2.00	1.00	0.50	0.20	0.10
32"	2.40	1.20	0.80	0.24	0.12
28"	3.20	1.60	0.80	0.32	0.16
24"	4.40	2.20	1.10	0.44	0.22

ORDERING INFORMATION

SAMPLE NUMBER: LBS10M12242BZL

Product Family LBS=Square Bollard with Stacked Louvers and Pyramid Top LBR=Round Bollard with Stacked Louvers and Dome Top	Lamp Wattage ¹ 35=35W 50=50W 70=70W 10=100W	Lamp Type M=Metal Halide S=High Pressure Sodium	Socket 1=Medium	Ballast 1=NPF 2=HPF	Voltage ² 2=120V 0=208V 4=240V 7=277V W=Multi-tap wired 120V	Fixture Height 24=24" 28=28" 32=32" 36=36" 42=42"	Colors (add as suffix) AP=Grey BK=Black BZ=Bronze DP=Dark Platinum GM=Graphite Metallic WH=White	Options (add as suffix) 1=Single Fuse (120, 277 or 347V) Specify Voltage 2=Double Fused (208 or 240V) Specify Voltage R1=Provisional Cut for GFI Receptacle ⁴ R2=Installed GFI Receptacle ⁴ L=Lamp Included

NOTES: 1 All lamps are medium-base. 2 35W High Pressure Sodium available in 120V only. 3 Refer to technical section for lamp/ballast/voltage compatibility. 4 Location of R1 and R2 option on housing subject to height of luminaire. 5 Specifications and dimensions subject to change without notice.

NOTE: Specifications and dimensions subject to change without notice.



County of San Mateo - Planning and Building Department

ATTACHMENT N

County of San Mateo
Environmental Services Agency
Planning and Building Division

In-Lieu Park Fee Worksheet

[This formula is excerpted from Section 7055 of the County's Subdivision Regulations]

This work sheet should be completed for any residential subdivision which contains 50 or fewer lots. For subdivisions with more than 50 lots, the County may require either an in-lieu fee or dedication of land.

1. For the parcel proposed for subdivision, look up the value of the land on the most recent equalized assessment roll. (Remember you are interested in the land only.)

Value of Land = 585,063

2. Determine the size of the subject parcel in acres.

Acres of Land = 5.12

3. Determine the value of the property per acre.

- a. Set up a ratio to convert the value of the land given its current size to the value of the land if it were an acre in size.

Formula:	
<u>Parcel Size in Acres (From Item 2)</u> 1 Acre of Land	<u>Value of Subject Parcel (From Item 1)</u> Value of Land/Acre
Fill Out:	
<u>5.12</u> 1 Acre	<u>585,063</u> Value of Land/Acre

- b. Solve for X by cross multiplying.

Formula:	
Value of Land =	$\frac{\text{Value of the Subject Parcel (From Item 1)}}{\text{Size of the Subject Parcel in Acres (From Item 2)}}$ =
Fill Out:	
Value of Land =	$\frac{585,063}{5.12} = 114,270.11$



County of San Mateo - Planning and Building Department

ATTACHMENT O

DRAFT
Development Agreement

THIS DEVELOPMENT AGREEMENT ("Agreement") is made and entered into on _____, 2015, by and between the COUNTY OF SAN MATEO, a political subdivision of the State of California ("County"), BIG WAVE GROUP, a IRC § 501(c)3 non-profit entity, and BIG WAVE, LLC, a California Limited Liability Company (collectively "Developer"), pursuant to the authority of California Government Code Sections 65864, *et seq.*

RECITALS

A. California Government Code Sections 65864, *et seq.*, authorize the County to enter into an agreement for the development of real property with any person having a legal or equitable interest in such property in order to establish certain development rights in such property.

B. On October 18, 2005, Developer initially submitted an application to develop certain real property owned by Developer, which application includes a request for a Coastal Development Permit, Use Permit, Tentative Subdivision Map and Grading Permit to develop housing for Developmentally Disabled Adults ("Wellness Center") and an Office Park on property it owns identified as Assessor Parcel Nos. 047-311-060 and 047-312-040.

C. County approved various land use approvals in connection with the development of the Project on March 15, 2011. The approvals included the following: (1) a Use Permit, pursuant to Sections 6288.2 and 6500(d)3 of the County Zoning Regulations, for the sanitarium component of the Wellness Center and its accessory uses, as well as uses within the Airport Overlay (AO) Zoning District, consisting of 10,000 sq. ft. of commercial public storage use, 6,000 sq. ft. of communications and backup power uses, and 4,000 sq. ft. of miscellaneous Wellness Center storage use; (2) a Major Subdivision, pursuant to the County Subdivision Regulations, to subdivide the northern parcel of the project site into ten lots as described in Alternative C of the EIR and a Minor Subdivision to subdivide the southern parcel of the project site into three lots; (3) a Coastal Development Permit CDP), pursuant to Section 6328.4 of the County Zoning Regulations, for eight Office Park buildings (four 2-story and four 3-story buildings) containing 225,000 sq. ft. of mixed-office uses and a 640-space parking lot as described in Alternative C of the EIR, two Wellness Center buildings (one single-story building and one 3-story building) containing a maximum of 57 dwelling units to provide affordable housing for a maximum of 50 developmentally disabled adults and 20 staff persons and a 50-space parking lot, a 10,000 sq. ft. commercial public storage use, wetland habitat restoration and creation and other landscaping, associated fencing and grading, use of an existing agricultural well for domestic purposes, and establishment of a mutual water service company and a community wastewater treatment and recycling system; (4) a Design Review Permit, pursuant to Section 6565.3 of the County Zoning Regulations, for proposed structures and associated grading; and (5) a Grading Permit, pursuant to Section 8600 of the San Mateo County Ordinance Code, to perform 26,050 cubic yards of balanced cut and fill (collectively, together with any approvals or permits now or hereafter issued with respect to the Project, the "Project Approvals").

D. Pursuant to the California Environmental Quality Act ("CEQA") the County prepared an Environmental Impact Report ("EIR") for the Project. The EIR was certified by the Board of

Supervisors on March 15, 2011. Pursuant to CEQA, a mitigation/monitoring program for the Project was approved by the Board of Supervisors.

E. On appeal, the CDP required for the project was denied by the California Coastal Commission. Further, legal actions were filed by the Montara Water and Sanitary District, the Granada Sanitary District, the Committee for Green Foothills, and the Developer regarding the approvals and denials in San Mateo County Superior Court. The parties involved in those actions have entered into extensive settlement discussions to resolve the dispute. Now the Developer has proposed the North Parcel Alternative ("NPA") which is the subject of this Development Agreement.

F. The NPA was submitted to the County of San Mateo on March 13, 2013. It was submitted to other parties to the CEQA litigation on May 22, 2013. The NPA is a substantially smaller project from the one approved in 2011, and there are no new significant adverse environmental impacts that would result from the approval of the NPA. Under the NPA, the Developer is moving most of the development to the northern parcel. The southern parcel would be divided into 2 parcels. One parcel would contain space for boat parking and storage and other future structures and uses, in accordance with the Conditions of Approval dated _____. The second parcel would be offered for sale to either an entity seeking mitigation credit or desirous of dedicating open space. In any event, the future use of that site will be for open space uses. The northern parcel would now site the previously designed Wellness Center consisting of 57 bedrooms for 50 developmentally disabled adults and 20 staff persons and accessory administrative uses. The building space dedicated to business uses on the northern parcel has been reduced from 225,000 sq. ft. to 176,000 sq. ft.

G. On _____, County approved an EIR Addendum (including an Addendum and Final Addendum) to the Big Wave Wellness Center and Office Park EIR under CEQA and County approved the NPA. Such approvals include the following: (1) a Use Permit, pursuant to Section 6500 of the County Zoning Regulations, for modern sanitarium component of the Wellness Center, outdoor parking uses in the Airport Overlay (AO) Zoning District, and an Outdoor Boat Storage Use; (2) a Major Subdivision, pursuant to the County Subdivision Regulations, of the north parcel into seven lots and the creation of up to 108 business condominium units, each approximately 1,500 sq. ft. in size; (3) a Minor Subdivision, pursuant to the County Subdivision Regulations, of the south parcel into two lots; (4) a Coastal Development Permit, pursuant to Section 6328.4 of the Zoning Regulations, appealable to the California Coastal Commission, for the proposed subdivisions, uses, and improvements; (5) a Design Review Permit, pursuant to Section 6565.3 of the Zoning Regulations, for proposed structures and associated grading; and (6) a Grading Permit, pursuant to Section 8600 of the San Mateo County Ordinance Code, to perform 735 cubic yards (cy) of cut for utility trenching and to place 16,400 cy of imported gravel. (Collectively, together with any approvals or permits now or hereafter issued with respect to the Project, these actions are referred to as the "Project Approvals.")

H. The purpose of this Agreement is to facilitate the implementation of the Project Approvals through the development of the Project, thereby realizing the public benefits to County and private benefits to Developer, including those described in these Recitals. The development of the Project will result in building a significant amount of affordable housing, subject to the Agreement for Affordable Housing at the Wellness Center, approved by the Board of Supervisors on _____, for Developmentally Disabled Adults on the San Mateo County Coastside and will provide an Office Park built in an environmentally sustainable manner and to contain industrial/office/storage uses, to help

address the jobs/housing imbalance in the Coastside.

I. The Board of Supervisors has found, among other things, that this Agreement is consistent with the County General Plan; that this Agreement is compatible with the regulations that prescribe the uses authorized in the Property; that this Agreement conforms with public convenience, general welfare, and good land use practice; that this Agreement will not be detrimental to the health, safety, or general welfare; and that this Agreement will not adversely affect the orderly development of property or the preservation of property values.

J. Developer is willing, pursuant to the terms of this Agreement, to make expenditures and provide benefits to the County including, the following: 1) building a Class 1 multipurpose Coastal Trail and make improvements to Airport Street, according to the schedule described in Section 5.3 of this Agreement and in accordance with the Conditions of Approval dated _____; 2) conveying to the County sureties for on-site and off-site improvements, including but not limited to, those related to traffic control-related improvements, prior to the recordation of any subdivision map; and 3) fully funding application and construction costs associated with a bridge widening project over the drainage swale separating the two parcels making up the Project site (i.e., APNs 047-311-060 and 047-312-040), as discussed in Section 5.3 of this Agreement, in the event the bridge widening project receives necessary entitlements and County approvals, thus conferring a public benefit on the County.

K. County desires the timely, efficient, orderly, and proper development of the Project and the Property, and the Board of Supervisors concludes that it is in the public interest to accept the benefits conferred by this Agreement and that it is in the public interest to provide for the vesting of Developer's rights to develop the Project in conformance with the Project Approvals and the terms and conditions contained herein so that such vested rights shall not be disturbed by changes in laws, rules, or regulations, including measures passed by initiative, that occur after the Effective Date (as defined below) of this Agreement, except as provided herein.

L. County and Developer have reached agreement and desire to express herein a development agreement that will facilitate development of the Project subject to conditions set forth in this Agreement and set forth in the Project Approvals, as defined herein.

M. On _____, the Board of Supervisors adopted Ordinance No. _____ approving this Agreement.

NOW, THEREFORE, with reference to the above recitals and in consideration of the mutual promises, obligations and covenants herein contained, County and Developer agree as follows:

AGREEMENT

1. Description of Property. The Property which is the subject of this Agreement is described in Exhibit A attached to this Agreement and incorporated herein by reference ("Property").

2. Interest of Developer. The Developer has represented and warrants to the County that it has a legal or equitable interest in the Property and that all parties with a legal interest in the Property are signatories hereto.

3. Relationship of County and Developer. This Agreement is a contract that has been negotiated and voluntarily entered into by County and Developer. The Developer is not an agent of County. The County and Developer hereby renounce the existence of any form of joint venture or partnership between them, and agree that nothing contained in this Agreement or in any document executed in connection with this Agreement shall be construed as making the County and Developer joint venturers or partners with respect to the Project and any other matter.

4. Effective Date and Term.

4.1. Effective Date. The effective date of this Agreement (“Effective Date”) shall be thirty days after the date on which San Mateo County Ordinance No. ____, the ordinance approving this Agreement, is adopted by County (i.e., _____, 2015). County and Developer recognize that the approval of this project may be appealed to the California Coastal Commission. Moreover, it is possible that litigation will be filed regarding the project approvals, including under CEQA. Therefore, County and Developer agree that, notwithstanding the foregoing, the Effective Date will not be deemed to occur until (a) all California Coastal Commission administrative procedures and decisions regarding the Project have been rendered; (b) all statutes of limitations for litigation regarding the Project have run; and (c) if any litigation is filed, a final judgment has been entered and all appeal periods have run. If any of these events occur, the County and Developer agree that all rights and obligations of the parties shall be extended for a period of time equal to the time that the occurrence of the Effective Date is tolled pursuant to this Section 4.1, such that Developer can apply for building permits after Coastal Commission jurisdiction and potential or actual litigation has ended which would have prevented Developer from obtaining building permits.

4.2. Term. The term of this Agreement (“Term”) shall commence on the Effective Date and extend for fifteen (15) years thereafter, unless this term is otherwise terminated or modified as set forth in this Agreement.

4.3. Term of the Tentative Map and Other Project Approvals. Pursuant to California Government Code Sections 66452.6(a) and 65863.9, the term of any tentative map and other Project Approvals described in the Recital above shall automatically be extended for the Term of this Agreement. The terms of other Project Approvals, other than any Coastal Development Permit issued by the California Coastal Commission under Public Resources Code sections 30604(b) and/or 30621, shall be extended for a period of time coterminous with the term of this Agreement, as set forth in section 4.2 of this Agreement. If any Coastal Development Permits issued by the California Coastal Commission pursuant to sections 30604(b) and/or 30621 of the California Public Resources Code expire prior to the expiration date of the other Project Approvals described in this Agreement, the County shall consider and act upon a Coastal Development Permit for the Project consistent with the other Project Approvals and, to the extent allowed by law, subject to the same conditions as those imposed on the Coastal Development Permit originally approved by the County, and approved by the California Coastal Commission on appeal, which shall have the same term as that set forth for the other Project Approvals set forth in this Agreement. The decision as to whether to approve or deny such a Coastal Development Permit shall be subject to the discretion of the applicable County decision making body. To the extent required by applicable law, the issuance of a Coastal Development Permit shall be subject to appeal to the California Coastal Commission. If any Coastal Development Permits issued by the California

Coastal Commission pursuant to the authorities cited in this Section 4.3 are inconsistent with the terms of this Development Agreement, the parties agree to meet and confer in good faith to discuss amendments to this Agreement needed to bring the Agreement into conformity with such Coastal Development Permit issued by the California Coastal Commission.

5. Use of the Property.

5.1. Right to Develop Pursuant to Existing Rules and Regulations. Subject to Section 7.1 of this Agreement, the County rules and regulations applicable to Developer's development of the Project on the Property shall be those in effect on the Effective Date, and any amendments to any of them as shall, from time to time, be adopted.

5.2. Permitted Uses. The permitted uses of the Property, the maximum density and intensity of use, the maximum height, bulk and size of proposed buildings on the Property, provisions for reservation or dedication of land for public purposes and location and maintenance of on-site and off-site improvements, location of public utilities, and other terms and conditions of development applicable to the Property, shall be those set forth in this Agreement, the Project Approvals, and any amendments to this Agreement or the Project Approvals, and the "Applicable Rules" (as defined in this Agreement).

The Project consists of five components: 1) the "Wellness Center" component on the north parcel, 2) the "Office Park" component on the north parcel, 3) the Boat Storage use on the south parcel, 4) Coastal Access Public Parking on the south parcel, and 5) Wetland and Buffer Zone Areas over both the north and south parcels. Each component is described as follows:

5.2.1. WELLNESS CENTER ON THE NORTH PARCEL. The "Wellness Center" component consists of the following:

5.2.1.1. The Wellness Center, a modern sanitarium use subject to the County-approved Use Permit, which includes affordable housing consisting of 57 bedrooms to accommodate 50 DD adults and 20 aides.

5.2.1.2. Ancillary Uses: These uses include a fitness center, commercial kitchen, laundry facilities, and administrative offices, among other ancillary uses, as described in the EIR Addendum.

5.2.1.3. Subdivision: The Wellness Center will be located on one lot (Lot 7) of the north parcel. Lot 7, which is 6.61 acres in size, includes three buildings. Building 1 consists of 23,250 sq. ft., Building 2 consists 21,170 sq. ft., and Building 3 consists of 47,000 sq. ft. (approximate sizes). This lot includes affordable housing consisting of 57 bedrooms to accommodate 50 DD adults and 20 aides. Lot 7 includes approximately 20,500 sq. ft. of business use that is not considered part of Wellness Center operations. Lot 1 will accommodate parking and common space, and Lots 2-6 will contain business buildings.

5.2.1.4. Project-Related Business Operations to Generate Income for Wellness Center Residents: The DD adults will be employed by the Wellness Center and will also

provide services to the Office Park, with the Wellness Center funded through association fees in accordance with the Conditions of Approval dated _____ and shared development costs. Business operations will be managed by Big Wave Group, Inc., a non-profit corporation, and include: Big Wave (BW) Catering/Food Services; BW Boat Storage; BW Energy; BW Farming; BW Water; BW Transportation; BW Recycling; BW Communications (radio telecom link); and BW Maintenance.

5.2.2 OFFICE PARK ON THE NORTH PARCEL

5.2.2.1. Office Park Component. The “Office Park” component of this Project consists of the following:

5.2.2.2. Uses: The “Office Park” refers to 176,000 sq. ft. of private business uses which are not operated by Big Wave Group, located on the north parcel. Business space is made up of General Office, Research and Development, Light Manufacturing, and Indoor Storage uses. Developer shall ensure that no more than the total authorized building square footage of 176,000 square feet of such uses is constructed. Such development both in size and intensity shall comply with County Parking Regulations at all times, such that the establishment/construction of uses or building square footage requiring parking in excess of the approved parking of 420 parking spaces for the Office Park is prohibited, even if total square footage does not exceed the total authorized building square footage.

5.2.2.3. Subdivision: The north parcel on which the Office Park is to be located will be subdivided into 7 lots. Lot 1 will be parking and common space, Lots 2 through 6 will be business buildings and Lot 7 will be the Wellness Center, as described above. Buildings 1 and 2 on Lot 7 contain a total of 20,500 sq. ft. of business use. Total area (approximated) of business uses by lot is outlined as follows: 33,500 sq. ft. on Lot 2; 32,000 sq. ft. on Lot 3; 30,000 sq. ft. on Lot 4; 30,000 sq. ft. on Lot 5; and 30,000 sq. ft. on Lot 6.

5.2.3 BOAT STORAGE USE ON THE SOUTH PARCEL. The “Boat Storage Use” component consists of the following:

5.2.3.1. Uses: The Boat Storage Lot will provide 21 boat storage spaces, 14 vehicle parking spaces associated with boat use and storage, and a 190 square-foot precast concrete restroom building. Driveways would allow for boats with trailers to be backed into the spaces. Locked security fencing would be constructed around the lot perimeter, with combination access for the boat owners. There would be no specific hours of operation, as the site would be accessible as needed by owners. The site would not be staffed full-time. This area may be developed with other priority uses and associated structures, in accordance with Conditions of Approval dated _____.

5.2.3.2. Subdivision of the South Parcel: The South Parcel will be subdivided into two lots. Both parcels would contain coastal access public parking. In addition, a 1.12-acre Boat Storage Lot and associated private parking (as described in Section 5.2.3.1) and an archeological site would be located on Lot 1 of the South Parcel. Approximately 3 acres of Lot 2 of the South Parcel would be undeveloped.

5.2.4 COASTAL ACCESS PUBLIC PARKING LOT ON THE SOUTH PARCEL. The “Coastal Access Public Parking Lot” component consists of the following:

5.2.4.1. Uses: A total of 92 spaces of coastal access public parking will be provided on Lots 1 and 2 of the south parcel. If fewer than the full number of authorized private parking spaces for business uses (i.e., 420 spaces) are built, Developer may proportionally reduce the number of coastal access public parking spaces that must be built, such that the number of coastal access public parking spaces built is equal to at least twenty percent (20%) of all private parking spaces built for the project.

5.2.4.2. Subdivision: A total of 92 coastal access public parking spaces would be located on Lots 1 and 2 of the south parcel.

5.2.5 WETLANDS AND BUFFER ZONES. The “Wetlands and Buffer Zones” component consists of the following:

5.2.5.1. Creation/restoration of approximately 7 acres of wetland habitat within areas of delineated wetlands and required 150-foot buffer zone on the north and south parcels. Developer must restore wetlands within 100 feet of the wetland boundary and may farm 50-feet of the buffer zone area located more than 100 feet of the wetland boundary, subject to restrictions as outlined in the conditions of approval. Developer will complete restoration activities within the time lines set forth in Section 5.3, below.

5.3. Timing of Construction and Protection of Undeveloped Lands. The project will be constructed in accordance with the following timeline and other Planning conditions:

5.3.1. Within one year of the final approval of the Coastal Development Permit for the project, the property owners shall:

5.3.1.1 Initiate implementation of the approved wetland restoration plan by establishing the nursery and seed stock of the plants that will be used for restoration; obtaining a grading and conducting the rough grading required to carry out the restoration plan and conducting said grading; planting areas disturbed by rough grading with the plant species called for by the restoration plan; and installing a barrier outside of the buffer zone following the completion of rough grading to prevent disturbance of the restoration area.

5.3.1.2. Fence the cultural site area located on the Wellness Center Property, in accordance with a plan and design for such a fence that shall be submitted for the review and approval of the Community Development Director and that shall minimize the visual impact of the fence by limiting its height and extent to the minimum necessary to avoid impacts to the cultural site, and by using materials that minimize view blockage and provide a natural appearance.

5.3.2. Within 2 years of the final approval of the Coastal Development Permit for the project, the property owners shall:

5.3.2.1. Construct the Class 1 trail adjacent to Airport Street in accordance with a construction plan submitted for the review and approval of the Directors of the County's Parks, Public Works, and Planning and Building Departments, as well as all other off-street improvements required by the Department of Public Works for recordation of the final map of the subdivision.

5.3.3. Within 3 years of the final approval of the Coastal Development Permit for the project, the property owners shall:

5.3.3.1. Complete the planting and irrigation required to implement the approved wetland restoration plan and initiate the 10-year monitoring program contained in the approved restoration plan.

5.3.3.2. Install the K-rail on the west side section of Airport Street that crosses the drainage separating the north and south parcels, unless the existing bridge is widened to accommodate a Class 1 trail across this drainage.

5.3.4. Within 5 years of the final approval of the Coastal Development Permit for the project, the property owners shall:

5.3.4.1. Construct Building 3 of the Wellness Center (25 bedrooms), the access and infrastructure improvements required to provide ingress and egress to the Wellness Center, the Wellness Center courtyards, and the 42 parking spaces that will serve the Wellness Center, which shall be located immediately adjacent to Building 3 and signed and reserved for Wellness Center residents, staff, and visitors.

5.3.4.2. Install at least 8 coastal access parking spaces on the south parcel, which shall be signed and reserved for use by the general public for the purpose of coastal access.

5.3.4.3. Install the portion of the approved landscaping plans that is adjacent to Airport Street over both parcels, and that is located within the footprint of the improvements described above.

5.3.4.4. Install the additional flexible sound barrier(s) if required by the County per Condition No. 4 a.b (Mitigation Measure NOISE-1).

5.3.4.5. Construct business uses on Lot 7 or the approved Office Park Building on Lot 2 of the north parcel, to the extent necessary to support Wellness Center operations. The building permit for this component of the project shall include construction of County-required parking spaces; County-required coastal access public parking spaces (a minimum of 20% of private parking spaces) to be provided on the south parcel; associated parking lot landscaping; accessways/driveways; adjoining courtyards; water, wastewater, and drainage and stormwater treatment systems; and comply with all the conditions of approval and requirements of the Development Agreement. Only as much parking as is required by the County for development approved under building permit(s) shall be constructed at one time. If required by the County, the additional flexible sound barrier(s), per Condition No. 4 a.b. (Mitigation Measure NOISE-1) will be installed during Wellness Center Construction. In no event will any construction for business uses take place prior to construction of the Wellness Center, Building 3.

5.3.4.5. Developer shall implement shuttle services to assist with the transportation needs of Wellness Center residents.

5.3.5. Within 12 years of the final approval of the Coastal Development Permit for the project, the property owners shall:

5.3.5.1 Wellness Center Buildings 1 and 2 shall be constructed within 12 years of the final approval of the Coastal Development Permit for the project, and prior to the construction of Office Park Buildings on Lots 4, 5, and 6. If constructed at different times, Wellness Center Building 2 shall be constructed prior to Wellness Center Building 1.

5.3.6. Construction of all remaining aspects of the project shall be completed within 15 years of the final approval of the Coastal Development Permit for the project. If fewer than the approved number of buildings has been built on the North Parcel at the end of the 15 year development term set forth in this Agreement, rights to develop undeveloped land within the approved development footprint (parking and building footprints) on the North Parcel under the approved permits shall expire at that time.

5.3.7. With the exception of the Office Park Building on Lot 2 and associated parking, construction of the Office Park Buildings and associated parking areas shall not commence until all project features required prior to 5 years of the final approval of the Coastal Development Permit for the project have been installed to the satisfaction of the Community Development Director and the Director of Public Works. Once this occurs, Office Buildings may be constructed in the following sequence: Office Park Building on Lot 2 (if not already built), Office Park Building on Lot 3, with the construction of any Office Park Building on Lot 6, Lot 4, and Lot 5 (in that order) to be permitted after the construction of all Wellness Center buildings. The plans for the construction of Office Buildings shall include the installation of the minimum amount of parking required to serve the building proposed for construction and its associated use, which shall be located immediately adjacent to the building(s) to be constructed, as well as the Coastal Access parking to be installed on the south parcel, the number of spaces of which shall be equivalent to 20% of the number of Office Park parking spaces proposed for construction. Notwithstanding the foregoing, Developer may construct multiple buildings, and associated Business Park and Coastal Access parking, simultaneously. In no event will any construction for business uses take place prior to construction of the Wellness Center, Building 3. No fill shall occur on the property outside of immediate areas proposed under a building permit for construction (i.e., building, access, and parking), to allow for agricultural use over areas that will be developed in a later phase.

5.3.8 *Obligations during the term of the Development Agreement:* Within the term of this Agreement, Developer will complete the following components of the Project:

5.3.8.1. *Requirement for Recordation of Final Map:* Prior to the recordation of the subdivision map for the north parcel, Developer shall convey to the County sureties for all onsite and offsite improvements, including, but not limited to, the sureties for the installation of

traffic control-related improvements. The Developer understands and agrees that neither the County nor the Department of Transportation (CalTrans) shall have any responsibility to fund any traffic improvements required pursuant to the Conditions of Approval for this project.

5.3.8.2. *Order of Construction of Project Buildings:* Construction of the Office Park Buildings and associated parking areas shall not commence until private and public parking, Class 1 trail, k-rail, landscaping and sound barrier (if required) features described in Section 5.3 of this Agreement have been installed to the satisfaction of the Community Development Director and the Director of Public Works. Once this occurs, Office Buildings shall be constructed in the following sequence: Office Park Building on Lot 2, Office Park Building on Lot 3, Office Park Building on Lot 6, Office Park Building on Lot 4, and Office Park Building on Lot 5. The plans for the construction of Office Buildings shall include the installation of the minimum amount of parking required to serve the building proposed for construction and its associated use, which shall be located immediately adjacent to the building(s) to be constructed, as well as the Coastal Access parking to be installed on the south parcel, the number of spaces of which shall be equivalent to 20% of the number of Office Park parking spaces proposed for construction. Notwithstanding the foregoing, Developer may construct multiple buildings, and associated Business Park and Coastal Access parking, simultaneously.

5.3.8.3. *Construction of Business Uses on the North Parcel:*

5.3.8.3.1. The County will not issue any building permits for any stand-alone business buildings until a building permit for a Wellness Center building has been issued and construction has commenced.

5.3.8.3.2. Each building permit application shall include provisions for County-required private parking, County-required coastal access public parking spaces to be provided on the south parcel (a minimum of 20% of private parking spaces), County-required accessways/driveways, complete associated parking lot landscaping, construct all adjoining courtyards and associated landscaping, and water, wastewater, drainage and stormwater treatment systems and shall comply with all the conditions of approval for the Project plans and the requirements of this Development Agreement. Once construction is initiated, each building is estimated to be constructed in approximately twelve months and Developer shall be required to make reasonable progress towards completion of construction once it has been initiated, it being understood and agreed that the Developer will complete construction of all Office Park buildings within the term of this Agreement and in compliance with the mitigation measure detailed in the Conditions of Approval dated _____. The Director of Community Development shall determine, in his reasonable judgment, whether reasonable progress has been made towards completion of such construction.

5.3.8.4. *Allocation of Parking for Business Uses:* Per Condition of Approval No. 7, Big Wave LLC shall cause the formation and require the continued existence of an association of all property owners on the north parcel for the management of parking spaces on Lot 1. Upon relinquishing ownership of Lot 1, Big Wave LLC shall form an association of all property owners on the north parcel, and shall transfer ownership of Lot 1 to that entity. No more than 420 parking spaces licenses shall be issued to owners of business uses on the north parcel. No more than 462 total parking spaces shall be provided at the north parcel. Parking licenses for business uses shall be issued based on County parking regulations and according to the schedule provided in Table 4 of the staff

report dated January 7, 2015. All tenants or business owners of business space at the north parcel shall obtain a building permit for a “change in use” prior to any construction/tenant improvement and occupancy. The County will verify that applicants for building permits have adequate parking space licenses for the proposed use prior to issuing any building permits and uses that are not supported by adequate parking will not be permitted.

5.3.8.5. *Beach User Parking (Phased with Building Permits)*: A total of 92 spaces of coastal access public parking will be provided on the south parcel. If less than the full amount of business use parking is built than otherwise authorized (420 parking spaces), Developer may proportionally reduce the amount of coastal access public parking that they build, such that public parking spaces built consist of no less than a minimum of 20% of all private parking provided for the project. Required coastal access public parking spaces shall be reserved and clearly marked for such uses, subject to review and approval by the Community Development Director, prior to the occupancy or change in occupancy of any Wellness Center building. Marking and spaces shall be maintained by the Developer for the life of the project. Parking fees shall not be collected for coastal access public parking spaces.

5.3.8.6. *Affordable Housing at the Wellness Center*: The property owner(s) shall maintain the rental rates for all bedrooms of the Wellness Center as affordable, such that the bedrooms are affordable to those of Extremely Low Income, Very Low Income, and Low Income, with the exception that residents may use up to 100% of their Social Security income for housing costs, which allows for residents who have no other income other than Social Security payments to use up to the full amount of their payment toward rental costs at the Wellness Center.

5.3.8.7. *Wellness Center Parking*: The Wellness Center shall be issued 42 irrevocable parking licenses.

5.3.8.8 *Other Benefits to County*: a) The applicant shall work with San Mateo County and others to address safety concerns regarding the neighboring propane tank property; b) The applicant shall work with the County to improve the function of the Prospect Way/Capistrano Road intersection; c) The applicant shall work with the County to direct bike and foot traffic to Marine Blvd. and improve vehicular access along Cypress Avenue as required by project conditions.

Notwithstanding the foregoing, Developer may perform multiple phases simultaneously.

6. Applicable Rules, Regulations, and Official Policies.

6.1. *Rules Regarding Permitted Uses*. For the term of this Agreement and except as otherwise provided in this Agreement, the County's ordinances, resolutions, rules, regulations, and official policies, including, without limitation, the Project Approvals, governing the permitted uses of the Property, governing density, design, improvement and construction standards and specifications applicable to the Property, including but not limited to, all public improvements, shall be those in force and effect on the Effective Date of this Agreement (the "Applicable Rules").

6.2. *Uniform Codes Applicable*. The Project shall be constructed in accordance with the provisions of the California Building, Mechanical, Plumbing, Fire, and Electrical Codes and applicable provisions of Title 24 of the California Code of Regulations, relating to Building Standards, in effect in

County at the time a completed application is submitted for the appropriate building, grading, or other construction permits for the Project. The Project shall be built to the LEED Gold or Platinum standards in effect at in County at the time a completed application is submitted for the appropriate building, grading, or other construction permits for the Project.

7. Subsequently Enacted Rules and Regulations.

7.1. New Rules and Regulations. During the term of this Agreement, the County may, in subsequent actions applicable to the Property, apply new or amended ordinances, resolutions, rules, regulations and official policies of the County which were not in force and effect on the Effective Date of this Agreement and which are not in conflict with the Applicable Rules, provided that (1) such new or modified ordinances, resolutions, rules, regulations or official policies do not affect the permitted uses of the Property, the maximum density and intensity of use, the maximum height, bulk and size of proposed buildings, provisions for reservations or dedication of land for public purposes and location and maintenance of onsite and offsite improvements, location of public utilities or any other terms and conditions set forth in this Agreement; and (2) such laws are generally applicable and not specific to or discriminatory against Developer's parcels that are the subject of this Development Agreement.

7.2. Denial or Conditional Approval. Nothing in this Agreement shall prevent the County from denying or conditionally approving any subsequent land use permit or authorization for any subsequent development project application on the basis of any new or modified ordinances, resolutions, rules, regulations, or policies applicable to the Property pursuant to and subject to Section 7.1.

7.3. Federal and State Law. Nothing shall preclude the application to the Project or the Property of changes in federal or state laws. To the extent any changes in federal or state laws prevent or preclude compliance with one or more provisions of this Agreement or development of the Property in conformance with the Project, the parties agree that the provisions of this Agreement shall be modified, extended, or suspended, as may be required to comply with such federal or state laws. Each party agrees to extend to the other prompt and reasonable cooperation in so modifying this Agreement.

8. Processing.

8.1. Further Approvals and Permits. On satisfactory completion by Developer of all required preliminary actions and payments of all required processing fees, if any, County shall, subject to all legal requirements, promptly initiate, commence, diligently process, complete at within a reasonable timeframe, all required steps, and expeditiously consider any approvals and permits necessary for the development by Developer of the Property in accordance with this Agreement, including, but not limited to, the following:

8.1.1. The processing of applications for and issuing of all discretionary approvals requiring the exercise of judgment and deliberations by County ("Discretionary Approvals"); and

8.1.2. The processing of applications for and issuing of all ministerial approvals requiring the determination of conformance with the Applicable Rules, including, without limitation, site plans, development plans, land use plans, grading plans, improvement plans, building plans and specifications, and ministerial issuance of one or more final maps, zoning clearances, grading permits, improvement permits, wall permits, building permits, lot line adjustments, encroachment permits,

certificates of use and occupancy and approvals, and entitlements and related matters as necessary for the completion of the development of the Project (“Ministerial Approvals”).

8.2. No Abridgement of Density or Height. County acknowledges that notwithstanding its ability to issue Discretionary Approvals in relation to site and architectural review and design review, County may not refuse such approvals, or require changes in the Project, that would have the effect of restricting or preventing the ability of Developer to construct buildings at the density and heights allowed in the Project Approvals as of the Effective Date of this Agreement.

8.3. Processing During Third Party Litigation. The filing of any third party lawsuit(s) against County or Developer relating to this Agreement or to other development issues affecting the Property shall not delay or stop the development, processing, or construction of the Project, or issuance of Discretionary Approvals or Ministerial Approvals, unless the third party obtains an order that, in the reasonable judgment of the County, prevents the activity.

9. Subsequently Enacted or Revised Fees, Assessments, and Taxes.

9.1. New Fees: County shall be entitled to impose and collect fees, dedications, and exactions on new development adopted by the County after the Effective Date provided that the ordinances, resolutions, rules, regulations or policies imposing them are generally applicable and not specific to or discriminatory against Developer’s parcels that are the subject of this Development Agreement.

9.2. Revised Application Fees. Any existing application, processing, and inspection fees that are revised during the term of this Agreement shall apply to the Project provided that (1) such fees have general applicability and do not discriminate against Developer; (2) the application of such fees to the Property is prospective.

9.3. New Taxes. Any subsequently enacted County taxes of general applicability shall apply to the Project provided that such taxes have general applicability and do not discriminate against Developer.

9.4. Assessments. Nothing in this Agreement shall be construed to relieve the Property from assessments levied against it by County pursuant to any statutory procedure for the assessment of property to pay for infrastructure and/or services which benefits the Property.

9.5. Right to Contest. Nothing contained in this Agreement shall prevent Developer from paying any such fee, tax, or assessment under protest, or otherwise asserting its legal rights to protest or contest a given fee, tax, or assessment assessed against the Project or the Property.

10. Amendment or Cancellation.

10.1. Modification Because of Conflict with State or Federal Laws. In the event that State or Federal laws or regulations enacted after the Effective Date of this Agreement prevent or preclude compliance with one or more provisions of this Agreement or require changes in plans, maps, or permits approved by the County, the parties shall meet and confer in good faith in a reasonable attempt to modify this Agreement to comply with such State or Federal laws or regulations. Any such amendment or

suspension of the Agreement is subject to approval by the Board of Supervisors, in its discretion. If such modification or suspension is infeasible in Developer's reasonable business judgment, then Developer may elect any one or more of the following in any sequence:

10.1.1. To terminate this Agreement by written notice to County, subject to payment to the County of all fees and charges due and owing;

10.1.2. To challenge the new law preventing compliance with the terms of this Agreement, and extend the Term of this Agreement for the period of time required to make such challenge. If such challenge is successful, this Agreement shall remain unmodified, except for the extension of the Term and shall remain in full force and effect. Nothing herein shall require the County to perform any action that, in its reasonable judgment, would cause it to violate controlling State or Federal authority.

10.2. Amendment by Mutual Consent. This Agreement may be amended in writing from time to time by mutual consent of the parties to this Agreement and in accordance with the procedures of State law.

10.3. Cancellation by Mutual Consent. Except as otherwise permitted in this Agreement, this Agreement may be cancelled in whole or in part only by the mutual consent of the parties or their successors in interest, in accordance with the same procedure used when entering into this Agreement.

11. Annual Review.

11.1. Review Date. The annual review date for this Agreement (the "Review Date") shall be one year following the Effective Date and the annual anniversary of said date each year thereafter.

11.2. Annual Review Process. The Community Development Director shall initiate the annual review by giving to Developer written notice within sixty (60) days following the Review Date that the County intends to undertake such review for the annual period ending with the Review Date. Developer shall provide evidence of reasonable compliance with the terms and conditions of this Agreement to the Community Development Director within thirty (30) days following receipt of the Community Development Director's notice. The Community Development Director shall review the evidence submitted by Developer and shall, within thirty (30) days following receipt of Developer's evidence, determine whether the Developer is in good faith compliance with this Agreement. The Community Development Director's determination that Developer has in good faith complied with the terms of this Agreement shall be final.

11.3. Hearing on a Determination that Developer Has Not Complied. If The Community Development Director determines that the Developer has failed to comply with the terms of this Agreement, he shall provide notice of this determination to the Developer. If, within ten (10) days of receiving such notice from the Community Development Director, Developer requests in writing that the Board of Supervisors review the finding, the Board of Supervisors shall schedule the topic of the Developer's good faith compliance with the terms of this Agreement as an agenda item for a meeting of the Board of Supervisors to be held within forty-five (45) days following such written request. The County shall give any required notice to the public in the time period required by law prior to such meeting of the Board of Supervisors. If, at such meeting, the Board of Supervisors determines that the

Developer is then in good faith compliance with the terms of this Agreement, then the Board of Supervisors shall adopt a resolution making such a finding, and such finding shall conclusively determine such issue up to and including the date of such Board of Supervisors meeting. If the Board of Supervisors determines that the Developer is not then in good faith compliance with the terms of this Agreement, then the Board of Supervisors shall take such actions as it finds appropriate to enforce or interpret the parties' rights and obligations under the terms of this Agreement, including, but not limited to, the modification or termination of this Agreement in accordance with State law. The burden of proof of good faith compliance with the terms of this Agreement shall be on the Developer.

11.4. Fee for Annual Review. The fee for County's annual review shall be paid by Developer, and shall not exceed the costs of reimbursement of County staff time, including but not limited to staff time for review of Traffic Impact Reports and other traffic analysis as called for in the Conditions of Approval, and expenses at the customary rates then in effect. Failure to timely pay the Fee for Annual Review shall be a material breach of this Agreement.

12. Default.

12.1. Other Remedies Available. On the occurrence of an event of default, the parties may pursue all other remedies at law or in equity which are not otherwise provided for in this Agreement expressly including the remedy of specific performance of this Agreement.

12.2. Notice and Cure. On the occurrence of an event of default by either party, the non-defaulting party shall serve written notice of such default on the defaulting party. If the default is not cured by the defaulting party within thirty (30) days after service of such notice of default, the non-defaulting party may then commence any legal or equitable action to enforce its rights under this Agreement; provided, however, that if the default cannot be cured within the thirty (30) day period, the non-defaulting party shall refrain from any such legal or equitable action so long as the defaulting party begins to cure such default within the thirty (30) day period and makes reasonable progress toward curing such default. Failure to give notice shall not constitute a waiver of any default.

12.3. Procedure for Default by Developer. If the County alleges that the Developer is in default under this Agreement, then after notice and expiration of the cure period described in paragraph 12.2, above, if the Developer has not cured the alleged default, County may institute legal proceedings against Developer pursuant to this Agreement or give owner written notice of intent to terminate or modify this Agreement pursuant to section 65868 of the California Government Code. Following notice of intent to terminate or modify as provided above, the matter shall be scheduled for consideration and review in the manner set forth in sections 65867 and 65868 of the Government Code within thirty (30) days following the date of delivery of such notice. Following consideration of the evidence presented in such review before the Board of Supervisors and a determination, on the basis of substantial evidence, by a majority vote of the Board of Supervisors that a default by Developer has occurred, County may (i) give written notice of termination of this Agreement to Owner, and this Agreement shall thereafter deemed terminated as of the date of delivery of that notice or (ii) propose a modification to the Agreement, which modification shall be adopted as provided in Section 11 of this Agreement if it is acceptable to all parties. Termination of this Agreement shall not render invalid any action taken by either party in good faith prior to the date on which the termination becomes effective. This paragraph shall not be interpreted to constitute a waiver of section 65865.1 of the California Government Code, but

merely to provide the procedure by which the parties may take the actions set forth in such Section 65865.1.

12.4. Procedure for Default by County. If County is alleged by Developer to be in default under this Agreement, Developer may seek to enforce the terms of this Agreement by an action at law or in equity, including, without limitation, by specific performance.

12.5. Estoppel Certificate. Either party may, at any time, and from time to time, request written notice from the other party requesting such party to certify in writing that, to the knowledge of the certifying party, (1) this Agreement is in full force and effect and a binding obligation of the parties, (2) this Agreement has not been amended or modified either orally or in writing, or if so amended, identifying the amendments, and (3) the requesting party is not in default in the performance of its obligations under this Agreement, or if in default, to describe therein the nature and amount of any such defaults. A party receiving a written request under this Section shall execute and return such certificate within sixty (60) days following the receipt thereof, or such longer period as may reasonably be agreed to by the parties. County Manager shall be authorized to execute any certificate requested on behalf of County. Failure to execute such an estoppel certificate shall not be deemed a default.

13. Severability. The unenforceability, invalidity, or illegality of any provision, covenant, condition, or term of this Agreement shall not render the other provisions unenforceable, invalid, or illegal, except that if it is determined in a final judgment by a court of competent jurisdiction that Developer's rights are not vested in the manner and to the extent agreed to in this Agreement, then the Parties shall meet and confer in a good faith attempt to agree on a modification to this Agreement that shall fully achieve the purposes hereof. If such a modification cannot be agreed on, then Developer or County may terminate this Agreement on 90-days' written notice to the other Party.

14. Transfers and Assignments.

14.1. Right to Assign. Developer's rights under this Agreement may be transferred, sold, or assigned in conjunction with the transfer, sale, or assignment of all or a portion of the Property subject to this Agreement at any time during the term of this Agreement; provided that, except as provided in this Agreement, no transfer, sale, or assignment of Developer's rights hereunder shall occur without prior written notice to the County and the written consent of the County Board of Supervisors. Any assignee/transferee shall be bound by the terms of this Agreement.

14.2. Release Upon Transfer. Upon the transfer, sale, or assignment of Developer's rights and interests hereunder pursuant to the preceding subparagraph of this Agreement, Developer shall be released from the obligations under this Agreement with respect to the Property transferred, sold, or assigned, arising after the date of Board of Supervisors approval of such transfer, sale, or assignment; provided, however, that if any transferee, purchaser, or assignee approved by the Board of Supervisors expressly assumes the obligations of Developer under this Agreement, Developer shall be released with respect to all such assumed obligations. In any event, the transferee, purchaser, or assignee shall be subject to all the provisions of this Agreement and shall provide all necessary documents, certifications, and other necessary information before Board of Supervisors approval.

14.3. Pre-Approved Transfers. Any transfer of any interest in the Project or the Property by Developer to an entity that is an affiliate of the Developer is permitted.

14.4. Foreclosure. Nothing contained in this Section 14 shall prevent a transfer of the Property, or any portion of the Property, to a lender as a result of a foreclosure or deed in lieu of foreclosure, and any lender acquiring the Property, or any portion of the Property, as a result of foreclosure or a deed in lieu of foreclosure shall take such Property subject to the rights and obligations of Developer under this Agreement; provided, however, in no event shall such lender be liable for any defaults or monetary obligations of Developer arising before acquisition of title to the Property by such lender, and provided further, in no event shall any such lender or its successors or assigns be entitled to a building permit or occupancy certificate until all fees due under this Agreement (relating to the portion of the Property acquired by such lender) have been paid to County.

15. Agreement Runs with the Land. Except as otherwise provided in this Agreement, all of the provisions, rights, terms, covenants, and obligations contained in this Agreement shall be binding on, and inure to the benefit of, the parties and their respective heirs, successors, and assignees, representatives, lessees, and all other persons acquiring the Property, or any portion of the Property, or any interest therein, whether by operation of law or in any manner whatsoever. All of the provisions of this Agreement shall be enforceable as equitable servitudes and shall constitute covenants running with the land pursuant to applicable laws, including, but not limited to, California Civil Code Section 1468. Each covenant to do, or refrain from doing, some act on the Property under this Agreement, or with respect to any owned property, (1) is for the benefit of such properties and is a burden on such properties, (2) runs with such properties, and (3) is binding on each party and each successive owner during its ownership of such properties or any portion thereof, and shall be a benefit to and a burden on each party and its property hereunder and each other person succeeding to an interest in such properties

16. Bankruptcy. The obligations of this Agreement shall not be dischargeable in bankruptcy.

17. Indemnification. Developer agrees to indemnify and hold harmless County, and its elected and appointed councils, boards, commissions, officers, agents, employees, and representatives from any and all claims, costs, and liability for any personal injury or property damage which may arise directly or indirectly as a result of any actions or negligent omissions by the Developer, or any actions or negligent omissions of Developer's contractors, subcontractors, agents, or employees in connection with the construction, improvement, operation, or maintenance of the Project.

18. Force Majeure. In addition to any specific provisions of this Agreement, performance of obligations under this Agreement shall be excused and the term of this Agreement shall be similarly extended during any period of delay caused at any time by reason of acts of God such as floods, earthquakes, fires, or similar catastrophes; wars, riots, or similar hostilities; strikes and other labor difficulties beyond the party's control; shortage of materials; the enactment of new laws or restrictions imposed or mandated by other governmental or quasi-governmental entities preventing this Agreement from being implemented; litigation involving this Agreement or the Project Approvals, which delays any activity contemplated under this Agreement; or other causes beyond a party's control. County and Developer shall promptly notify the other party of any delay under this Agreement as soon as possible after the delay has been ascertained.

19. Notices. All notices required or provided for under this Agreement shall be in writing and delivered in person or sent by certified mail, postage prepaid, by overnight delivery or by facsimile.

Notices required to be given to County shall be addressed as follows:

Steve Monowitz
Community Development Director
455 County Center, 2nd Floor
Redwood City, CA 94063
Telephone No: (650) 363-4161, (650) 599-7311
Facsimile No: (650) 363-4849

With Copy to:
Office of the San Mateo County Counsel
Attn: John Nibbelin, Chief Deputy
400 County Center, 6th Floor
Redwood City, CA 94063
Telephone No.: (650) 363-4757
Facsimile No.: (650) 363-4034

Notices required to be given to Developer shall be addressed as follows:

David J. Byers, Esq.

BYERS/RICHARDSON
259 W. 3rd Avenue
San Mateo, CA 94402-1551
Telephone No: (650) 759-3375
Facsimile No: (650)389-7157

A party may change its address for notices by giving notice in writing to the other party, and thereafter all notices shall be addressed and transmitted to the new address. Notices shall be deemed given and received on the earlier of personal delivery, or if mailed, on the expiration of 48 hours after being deposited in the United States Mail or on the delivery date or attempted delivery date shown on the return receipt, air bill, or facsimile.

20. Agreement Is Entire Understanding. This Agreement is executed in four duplicate originals, each of which is deemed to be an original. This Agreement constitutes the entire understanding and agreement of the parties.

21. Exhibits. The following documents are referred to in this Agreement and are attached to this Agreement and incorporated herein by reference as though set forth in full:

- Exhibit A: Legal Description of Property
- Exhibit B: Project Approvals
- Exhibit C: Topography of Southern Parcel
- Exhibit D: Topography of Northern Parcel

Exhibit E: Vesting Tentative Map (Date)

Exhibit F: Grading and Erosion Control Plan

Exhibit G: Landscaping Plan

Exhibit H: "Riparian and Waters/Wetland Ecosystem Restoration Final Basis of Design Report (also added to Attachment B of the EIR Addendum)

EXHIBIT I: As-Conditioned Phasing Plan

22. Recordation of Development Agreement, Amendment, or Cancellation. Within ten (10) days after the Effective Date of this Agreement, the Developer shall submit a fully-executed original of this Agreement for recording with the County Recorder. If the parties to the Agreement or their successors-in-interest amend or cancel the Agreement or if the County terminates or modifies the Agreement for failure of the Developer to comply in good faith with the terms or conditions of the Agreement, either party may submit for recording the notice of such action with the County Recorder.

IN WITNESS WHEREOF, the parties hereto have caused this Agreement to be executed as of the date and year first above written.

County of San Mateo

Big Wave, LLC

By: _____

By: _____

Byers / Richardson

By: David J. Byers

APPROVED AS TO FORM:

County Counsel

NOTARIAL ACKNOWLEDGMENT ATTACHED

EXHIBIT A: Legal Description of the Property

EXHIBIT B: Project Approvals

EXHIBIT C: Topography of Southern Parcel

EXHIBIT D: Topography of Northern Parcel

EXHIBIT E: Vesting Tentative Map, (date)

EXHIBIT F: Grading and Erosion Control Plan

EXHIBIT G: Landscaping Plan

EXHIBIT H: Riparian and Waters/Wetland Ecosystem Restoration Final Basis of Design Report

(also added to Attachment B of the EIR Addendum)

EXHIBIT I: As-Conditioned Phasing Plan



County of San Mateo - Planning and Building Department

ATTACHMENT P

DRAFT

**AGREEMENT BETWEEN THE COUNTY OF SAN MATEO
AND BIG WAVE GROUP AND BIG WAVE LLC**

This Agreement is made this _____ day of _____, 2015 between the County of San Mateo, a political subdivision of the State of California, and Big Wave Group, a non-profit corporation organized under the California Nonprofit Public Benefit Corporation Law, Corporations Code §§ 5110 et seq. and Internal Revenue Code § 501c(3) and Big Wave LLC, a limited liability company formed and existing under the laws of the State of California.

RECITALS

Whereas, Big Wave Group was formed by parents and concerned citizens to provide housing, employment and other opportunities for developmentally disabled adults who lack those opportunities in our communities;

Whereas, since 2005 the applicant for the Big Wave development has actively sought permits to build a Wellness Center to provide these opportunities for the developmentally disabled adult community;

Whereas, Big Wave Group will operate the proposed Wellness Center in the Big Wave development; and

Whereas, the County of San Mateo wants to ensure that housing in the Wellness Center shall remain affordable to the developmentally disabled community.

Now, therefore, the parties agree as follows:

TERMS

1. All housing at the Wellness Center shall remain rental housing for the life of the project. Rental rates for housing at the Wellness Center for developmentally disabled adults shall be set in a manner that recognizes the income limitations of those developmentally disabled adult residents and be maintained at such levels that they shall not exceed the

maximum affordable rent payment for those of Extremely Low Income, Very Low Income, and Low Income for the San Mateo County Income Limit Area, as defined by the United States Department of Housing and Urban Development and the San Mateo County Department of Housing.

2. Residents may use up to 100% of their Social Security income for housing costs.
3. The County of San Mateo will work to assist developmentally disabled adults who are residents of the Wellness Center with available federal and state housing funds targeted to individuals in the income levels discussed in Paragraph 1, above.
4. Big Wave Group will work with the County of San Mateo to identify and obtain federal, state and non-profit foundation support to assist in the financial viability of the Wellness Center.
5. Nothing in this Agreement shall act to limit Big Wave Group's obligation to fulfill its fiduciary obligations to act in the best interests of its residents, violate its legal obligations under state or federal law, to disclose records that would otherwise be confidential under law or otherwise intrude into the privacy of residents of the Wellness Center.
6. This Agreement is not intended to create any third party beneficiaries nor give rise to any private cause of action allowing attorneys to litigate against Big Wave Group in the hope of recovering attorneys' fees.
7. This is the sole agreement of the parties regarding the issue of rates charges to future residents of the Wellness Center. All modifications to this Agreement shall be in writing. All previous understandings merge into this Agreement.

Dated: _____

Big Wave Group

Dated: _____

Big Wave LLC

Dated: _____

County of San Mateo

Dated: _____

County Counsel, County of San Mateo

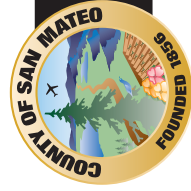

County of San Mateo - Planning and Building Department

ATTACHMENT Q

Appellants requested revisions/clarifications re: Big Wave Project 2/26/15

1. To reduce impacts of 33' high Wellness Center buildings on mobile home park residents, increase setback of Wellness Center buildings from 30' to 65'. Setback area includes: landscaping adjacent to Wellness Center: 10', parking stalls: 18', parking aisle/emergency fire access: 24', landscaping adjacent to Pillar Ridge fence: 13'.
2. Move or fully mitigate hazard from propane tank farm; possibly relocate to boat storage parking area on southern parcel.
3. Replace recently proposed Wellness Center fiberglass roof with material that prevents light from shining through the roof and off the property; specify type and design of replacement roofing.
4. Construct Class I bike/pedestrian path along east side of Airport Street, and south side of Cypress from Airport to Highway One.
5. Reduce total square footage of commercial space to 155K (which was the original proposed square footage in 2006, current NPA square footage is 189k, which may already have been reduced due to design changes).
6. Provide a narrative and plans detailing the stormwater retention and pollution prevention system including calculations as to how it will meet the 10-year and 100-year storm event. County (or independent peer review) needs to review plans for adequacy prior to BOS hearing on the Appeal.
7. Place a Conservation Easement and/or Deed Restriction on remainder of southern parcel to ensure no structures are built there; appellants will continue to pursue buyer of southern parcel for wetlands restoration.
8. Add statement that conditions of approval run with the land.
9. Appellants need to discuss/clarify improvements to the intersection of Cypress and Highway One, and feasibility of widening Cypress – what is the width of the Cypress right of way at Highway One and is widening feasible? There appears to be conflicting language regarding this intersection between the Staff Report (page 23, last paragraph regarding Traffic and Parking) and Condition of Approval (Mitigation Measure 4.a.e., TRANS-1, pages 58-59, excerpted below)
10. Appellants note that the intersection at Mezza Luna (Prospect/Capistrano/Broadway) already experiences congestion; what mitigation would successfully address this problem area?

Staff Report, page 23: Regarding the potential for increased project traffic if only office uses are established, **Mitigation Measure TRANS-1 (Condition No. 4.ae) requires construction of the approved mitigation measure (i.e., signal or roundabout) at the time the signal warrant is met at the Cypress Avenue and Highway 1 intersection.** To determine when the signal warrant has been met, the mitigation measure requires the property owner(s) to submit a traffic report after occupancy of the first 30,000 sq. ft. of business space and after the occupancy of every additional 40,000 sq. ft. of business space, until full build-out or until the mitigation measure has been constructed. If only office uses are established, the signal warrant would be met, and the mitigation constructed, sooner than if other lower intensity uses were established.

Mitigation Measure 4.a.e., TRANS-1 (pages 57-58): **Construction of the approved mitigation measure is required prior to the occupancy of any Office Park Building or business space at the Wellness Center (excluding Wellness Center-operated businesses) unless the property owner(s) submits evidence that Caltrans has determined that the stoplight or roundabout should not be installed until the signal warrants are met.** If this is the case, the property owner(s) shall submit a traffic report to the Department of Public Works after the occupancy of the first 30,000 sq. ft. of business space and after the occupancy of every additional 40,000 sq. ft. of business space until full build-out or until the mitigation measure has been constructed.

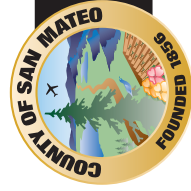

County of San Mateo - Planning and Building Department

ATTACHMENT R

March 11, 2015

Attn: Camille Leung
Re: Agreement with Appellants

Dear Camille,

On March 11, 2015, representatives from Big Wave met with a representative from the project Appellants to discuss the Appellants' requested revisions. Per our discussions, the following revisions to the NPA appear to address the concerns of the Appellants while maintaining a viable project for Big Wave.

1. Increase the setback to 65-foot from the mobile home park that includes one row of parking next to the Wellness Center, and a 13' landscaping strip next to the mobile home park fence. This would be accomplished by shifting the Wellness Center and office park to the south and reducing an equivalent number of parking spaces on the southern end of the office park.
2. Work with San Mateo County and others to address safety concerns regarding the propane tank farm.
3. Provide an opaque coating on the basketball court cover or alternate roof material that prevents outside illumination and miscellaneous light pollution.
4. Provide a Class 1 trail along the length of the Big Wave Property on the east side of Airport Street if the County approves and selects the east side of Airport Street for the Coastal Trail. Provide a 5-foot sidewalk on the west side of Airport Street adjacent to its property if the County decides to locate the bike/pedestrian trail and provides for the right-of-way for the trail on the eastside of Airport Street.
5. Reduce the total commercial square footage by 13,000 square feet on the North Parcel.
6. Big Wave will provide a detailed narrative describing the project storm water drainage system.
7. Agree to a conservation easement or deed restriction on the southern parcel limiting any future development to 12,000 square feet of buildings, maximum 24' height, and parking only on the area shown on the NPA as outdoor boat storage. The coastal access parking would remain as shown on the NPA.
8. Big Wave agrees that all of the conditions will run with the land.
9. Agree to install a signalized intersection at Cypress and Highway 1. Work with the County to direct bike and foot traffic to Marine Blvd. and improve vehicular access along Cypress as required by the County Conditions.
10. Big Wave agrees to work with the County to improve the function of the Prospect/Capistrano intersection.

Sincerely yours,
Jeff Peck

Appeal of PLN 2013-00451: Revised Big Wave North Parcel Alternative Project, Owner: Big Wave Group; Big Wave LLC, Applicant: David Byers

Appellants: Committee for Green Foothills, Loma Prieta Chapter, Sierra Club, San Mateo Chapter, Surfrider Foundation, Pillar Ridge Homeowners Association

Basis for Appeal of Use Permit, Major and Minor Subdivisions, Design Review Permit and Coastal Development Permit:

- 1. Major Subdivision:** The Vesting Tentative Map (VTM) for the Northern Parcel does not meet the requirements of the County Subdivision Regulations which require the VTM to show the location and dimensions of all proposed parcel lines, the location of driveway and parking area improvements with type of pavement, curbs, gutters and sidewalks, and the location, width and purpose of all existing and proposed easements, together with all applicable building and use restrictions. Some of these details are scattered throughout other documents; others are missing entirely. These are important elements of the project and not mere details that can be left to staff review and approval before filing of the Final Map.
- 2. Minor Subdivision:** The Tentative Parcel Map (TPM) for the Southern Parcel similarly lacks essential details including layout of the required 92 coastal access public parking spaces, and overall dimensions and square footage of the boat storage area with number of boat storage spaces.
- 3. Visual Impacts:** There is inadequate information regarding the visual impacts of the proposed project. Story poles and orange netting or photo simulations that show the office park and Wellness Center buildings from public viewing locations, including along Airport Street, are needed. Without this information, the project's visual impacts cannot be evaluated. Even without story poles or photo simulations, it's clear that the Wellness Center's three buildings do not comply with LCP Policy 3.13 that states: "Require that new development providing significant housing opportunities for low and moderate income persons contribute to maintaining a sense of community character by being of compatible scale, size, and design." Nor does the overall project comply with LCP Zoning Regulation 6565.17 (L), which requires: "The design of the structure is appropriate to the use of the property and is in harmony with the shape, size and scale of adjacent buildings in the community." The only buildings adjacent to the northern parcel are the Pillar Ridge manufactured home community consisting of one-story homes, a 17' high Community Center building and two warehouses just beyond to the north. The maximum height of all these buildings is 24'; their overall mass and bulk are also far smaller than those of the proposed project. There are no adjacent buildings to the east, west, or south; as Airport

Street is adjacent to the project site on the east, and County parkland is adjacent on the west and south . The Coastside Design Review Committee (CDRC) voted twice to deny the Design Review permit; we agree with their Findings. Overall project size needs to be reduced.

4. **Stormwater Runoff:** There is inadequate information and clarity in the Project Description, VTM, TPM, and other materials regarding potential impacts of the project's stormwater runoff on adjacent wetlands/riparian areas and sensitive habitats of Pillar Point Marsh. The revised project proposes to infiltrate all stormwater runoff from buildings and parking lots through subdrain pipes under the developed areas of the Northern Parcel. The previous project included stormwater detention and retention ponds, infiltration basins, rain gardens, and bioswales for retention and treatment of polluted stormwater from parking lot runoff; these have been deleted from the proposed project. The project site is underlain by an impermeable clay layer 3-5' below the surface (per soil test pits, borings and trenching). Trenching in November 2014 to confirm lack of branch faults associated with the Seal Cove Fault system encountered groundwater 7' below the surface, which required continuous pumping to maintain dry conditions in the 10' deep trench. The timing of this trenching during the second year of major drought reflects the most favorable conditions possible for infiltration of project stormwater. The presence of groundwater at 7' calls into question the assumption that there is sufficient subsurface capacity for infiltration of storm drainage during a 10-year storm. Without this information, necessary findings cannot be made regarding potential impacts from stormwater runoff to adjacent wetlands and the Pillar Point Marsh and the project's compliance with the resource protection policies of the LCP, particularly Sensitive Habitats Policy 7.3.b.
5. **Coastal Access/Traffic:** The proposed project site lacks direct access to Highway One; traffic must use substandard, inadequate streets for access. The southern route through Princeton via Capistrano/ Prospect/ Broadway/California/ Cornell to Airport is difficult to navigate due to narrow streets congested with coastal recreational visitors and industrial deliveries and operations. The northern route via Highway One/Cypress to Airport follows narrow 21' wide Cypress Avenue that is further constrained by deep ditches and narrow bridge over San Vicente Creek, a well documented habitat of California red-legged frog. Coastal access to the Fitzgerald Marine Reserve, Pillar Point Bluff and Maverick's Trails, the Princeton shoreline and other visitor serving locales will be negatively impacted by traffic generated by the proposed project, contrary to coastal access and recreation policies of the LCP and Coastal Act. Cypress and Princeton road segments were not adequately analyzed for the increased traffic impacts on vehicles, bicycles, and pedestrians. The proposed trail

segment in front of the project site is inadequate mitigation for these impacts on all the affected road segments.

6. **Future Development of Southern Parcel:** The approximately 1-acre area on the Southern Parcel proposed for boat storage has no restrictions as to future uses, and thus would readily be available for future development per the Waterfront Zoning District. The Waterfront zoning would allow a 3-story building of approximately 120,000 sq. ft. The density of the Wellness Center has been transferred to the Northern Parcel; therefore the Southern Parcel should be entirely protected from structural development by a Conservation Easement or other permanent protection. Otherwise this would be an impermissible segmentation of the project.

Basis for Appeal of CEQA Certification:

1. **The EIR Addendum and Final Addendum is incomplete and inadequate, has inherent inconsistencies and contradictions in the Project Description and analysis thereof.** The November 2014 published EIR Addendum was for a “4 Building Option” that was based on a misunderstanding of the intent of the Design Review Committee. At the November 12, 2014 Planning Commission hearing based on public opposition to the “4 Building Option”, the Commission directed staff to refer the new revision called the “8-Building Option” to the Coastsides Design Review Committee, the California Coastal Commission, and the Mid Coast Community Council for their review and comment. The “8-Building Option” became the Preferred Alternative. However, instead of amending the Project Description, Maps, and relevant text in the EIR Final Addendum, Staff has hastily cobbled together a Memo that sweepingly amended the Final Addendum. The EIR Addendum’s Project Description, Maps, and relevant text should be amended and corrected, where necessary, so that there is no confusion, contradiction, or conflict between the published Final EIR Addendum “4 Building Option” (November 2014) and the “8 Building Option” as revised and certified by the Planning Commission (January 2015).
2. **New hazards to Wellness Center residents:** There has been no evaluation in the EIR or EIR Addendum of potential hazards to residents of the Wellness Center from the adjacent propane tank farm. The Grading, Utility, and Erosion Control Plan (George Meu Associates, 1/10/15) shows a new four-foot high propane deflection wall which would presumably provide some limited protection for the Wellness Center residents, but would have unintended and serious consequences of diverting gas or liquid spills from the tank farm to the residents of the adjacent Pillar Ridge community. This is a new, potentially significant impact that was not analyzed in the EIR. At the Planning Commission hearing, the Applicants stated that they would

eliminate the wall and instead construct a ditch to Airport Street. This is not physically possible as Airport Street is higher than the low point of the tank farm, and in order to flow downhill, a ditch or swale would need to cross through the parking lot and driveway entry which would create potential impediments to vehicle ingress/egress for the project site.

3. **New visual impacts from domed fiberglass roof of Wellness Center:** The EIR and EIR Addendum did not evaluate the visual impacts from a new element in the revised project that was added to the plans in January 2015: the large curved clear fiberglass roof over the Wellness Center courtyard/basketball court. This fiberglass roof would allow spillover light to escape upwards and outwards from the Wellness Center roof, creating potential impacts to adjacent residents, Pillar Point Bluff, and the Airport. Spillover light would also have the potential to become diffused and refracted under cloudy or foggy conditions, creating a major glowing phenomenon that would be visible for longer distances, similar to lighted greenhouses. This new element is not permitted by Mitigation Measure AES-4 which states (in relevant part): “The lighting plan shall prohibit light spillover across property lines and limit lighting to the minimum necessary for security and exterior lighting purposes... All lighting shall be designed to be compatible with surrounding development. The project shall not propose light sources that are typical of the surrounding environment.”
4. **Wind funnel effects from large buildings on airport operations:** The EIR and EIR Addendum still do not include studies and analysis of potential wind impacts created by the proposed project’s buildings, despite requests by pilot organizations and individuals. While the revised project’s buildings are lower than previously proposed, they still could create funnel effects due to the shape, placement, and relationship of the buildings to each other and to the prevailing winds. The area of the runway where altered winds are likely to occur is one of the most critical phases of flight – just prior to touchdown, when planes are at low or no power and low speed, and after departure if the reciprocal runway is used.
5. **Impacts of noise on Pillar Ridge and Wellness Center residents:** The EIR and EIR Addendum still do not include studies and analysis of aircraft noise from the entire length of the runway reflected from buildings of the Wellness Center and Office Park that may potentially impact residents of the Pillar Ridge community. The requirement for residents of the Wellness Center to sign an Avigation Easement may be discriminatory and is likely ineffective as it does not preclude family members or others from complaining about impacts to this sensitive population. The FAA, Caltrans Division of Aeronautics, and San Mateo County Public Works have all written letters regarding the incompatibility of housing for developmentally disabled persons so close to the airport runway.

Process/ Brown Act Issues:

Several letters submitted to the Planning Commission at the January 14, 2014 hearing were not available for the public to review. At least two of these letters were from organizations (Sierra Club and LCP) that appealed the County's previous approval of the project to the Coastal Commission. Another missing letter was from Richard Newman, Chair of ALUC, but writing as an individual pointing out CEQA deficiencies regarding noise and wind effects. Failure to provide at least one copy of comment letters for public review is a potential violation of the Brown Act (Section 54957.5 (a)(2)) which requires that any writing that is a public record that is distributed less than 72 hours prior to a public meeting must be made available for public inspection at the time the writing is distributed to the decision making body.

Revised Findings (#s1 and 2.m) and Revised or New Conditions of Approval (#s 5, 5.n, 7, 60, and 88.d), were presented by Staff at the Planning Commission hearing, but hard copies were not available for the public to review. Staff's visual presentation was impossible for members of the audience to see, and the inadequate sound system made it difficult to hear. As a result, the public was unable to understand and/or intelligently comment on these important changes to the Findings and Conditions. This is also a potential violation of the Brown Act.

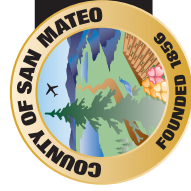

County of San Mateo - Planning and Building Department

ATTACHMENTS

Big Wave Storm Water Infiltration Treatment System

Goals and Objectives

- No point discharges into federal waters. This is not allowable without an NPDES permit.
- Provide a significant reduction in storm water runoff from existing conditions
- Provide filtration and biological treatment for all storm water generated onsite
- Provide a storm water infiltration system that captures a 10 year storm. This value will exceed the County Storm Water Management Requirements described in the Section C.3 regulations by over 40% and exceeds the capacity of all storm water systems in Princeton.
- At the 10 year storm, the majority of Princeton is flooding with the exception of Big Wave where rainwater is still being infiltrated. Flows exceeding the 10 year storm are directed to a series of grassy swales contained by permanent organic farmed raised rows where filtration and additional infiltration will occur.
- Essentially eliminating all surface runoff while protecting the flow of shallow ground water that feeds the Fitzgerald Marsh. Provide infiltration rates that exceed the agricultural pumping rates by 100% providing sustainable hydrology.
- Insure that no excess runoff beyond the 10 year storm will cause erosion or sediment transfer outside of the storm water treatment and infiltration system.

Project Geology

Percolation tests, trench data, borings and published data indicates that the surface soils on the North Parcel have a percolation rate of about 0.6 inches per hour in the upper 4 to 7 feet (clayey loam) underlain by a layer of clean sand have a percolation rate of 2.27 inches per hour. Below this strata, is a layer of dense clay essentially sealing off the shallow ground water from the deeper ground water.

Storm Water Design Conditions

The storm water calculations are provided on the attached table. The infiltration area (including all buildings and parking lots) is approximately 9 acres. The building roof area is approximately 3 acres. The organic farming area is approximately 3.3 acres (1.8 acres of raised beds and 1.5 acres of grassy swales) the restored wetlands is approximately 6.6 acres. The total area of roof drainage trenches and utility trenches extending into the permeable sands is approximately 0.2 acres. The storm water flows from the site were calculated to be approximately 6 cubic feet per second (CFS) for the C.3 county storm, 7.8 CFS for the 10 year storm and 16.8 CFS for the 100 year storm. Gravel with a void ration of .3 is required for storage. The required depth of gravel to store the C.3 storm is about 1 inch. The required depth of gravel for a 10 year storm is approximately 10 inches.

Storm Water System Design

For each permitted project, the site will be cleared for the permitted buildings and parking areas. Building piers, utility and roof drainage trenches will be installed. Trenches will be lined with soil fabric and back filled with gravel. The remainder of the site within the developed area (with the exception of the utility trenches) will be covered with fabric and filled with a minimum of 1 foot of gravel. Gravel thickness will vary from 1 to 2 feet. The building slabs will be placed and supported by the piers. A leveling course of course sand will be installed for finish grade, building access and to support the pavers as shown in the project drawings.

The finish grade varies from 28 feet at the north end of site to 18 feet at the south end of the site. Roof water will be directly routed to the underground drains. Storm water (rainwater falling on the parking lot and plaza) will flow across the developed area and will infiltrate across the site yielding a net zero flow for the 10 year storm as it approaches the southern curb in the developed area.

The permanent row organic farming system is designed to capture all flow exceeding the 10 year storm. The 50 foot section of farming includes six 4 foot rows approximately 1000 feet long separated by five 4 foot wide grassy swales. Storm water exceeding the 10 year storm will overflow the parking lot into two swales, 1000 feet long. Flow levels will be up to 1 foot in depth and maintain a maximum velocity of 1 foot/second. This flow depth will not allow erosion in the swales and allow for collection of any sand and silt in the grassy swales. During the rainy months, the rows will be planted in a cover crop of grass, beans and peas. This will provide structural stability of the rows and also nitrogen capture for the nutrient cycle. After flow down two rows, excess water will sheet flow over a 500 foot section of the last row at a velocity of less than 0.1 feet per second resulting in a clean flow with no erosion.

Biological treatment is achieved by maintaining the soil bacterial culture active in an aerobic zone in the gravel and surface soils. This system functions similar to a leach leach field for the treatment of oil drippings and organic material in storm water. Maintenance will include vacuuming out the sand space between by the pavers and annual replacement. Leaves, debris and litter will be collected on a weekly basis.



County of San Mateo - Planning and Building Department

ATTACHMENT T

CALIFORNIA COASTAL COMMISSION

NORTH CENTRAL COAST DISTRICT OFFICE
45 FREMONT STREET, SUITE 2000
SAN FRANCISCO, CA 94105
PHONE: (415) 904-5260
FAX: (415) 904-5400
WEB: WWW.COASTAL.CA.GOV



January 14, 2015

Camille M. Leung
Senior Planner
San Mateo County Planning and Building Department
455 County Center, Second Floor
Redwood City, CA 94063

Subject: San Mateo County Coastal Development Permit (CDP) Application PLN 2013-00451 (Big Wave) Executive Summary and Supplemental Staff Report, January 14, 2015

Dear Ms. Leung:

Thank you for sending the Coastal Development Permit (CDP) Application PLN 2013-00451 Executive Summary and Supplemental Staff Report for the Big Wave 8-Building Alternative dated January 14, 2015 (Staff Report) received via email on January 8, 2015, provided by San Mateo County (County). This Staff Report has been prepared for tonight's Planning Commission hearing on the proposed project. The 8-Building Alternative includes subdivision of two parcels (APN 047-311-060 subdivided into 7 lots and APN 047-312-040 subdivided into 2 lots); construction of 5 office park buildings totaling 162,000 square feet; 3 wellness center buildings totaling 97,520 square feet and related improvements; construction of a concrete restroom and boat storage parking; and grading consisting of 736 cubic yards of cut and 16,400 cubic yards of fill. The proposed project is located on the west side of Airport Street, north of Stanford Avenue and across the street from the Half Moon Bay Airport, in the unincorporated Princeton area of San Mateo County. Based upon our preliminary review of the above referenced document, we would like to make the following comments on some of the major remaining issues. Please ensure that these comments are made available to the Planning Commission for tonight's hearing.

- 1. Size, Scale, Density and Community Character:** The Staff Report includes only a limited analysis of the proposed project's consistency with the size, scale, density and community character of the surrounding Princeton Community. In addition, the financial feasibility of the project as it relates to the size and scale has not been adequately addressed.

With respect to size, scale and density, many interested parties have raised concerns with respect to this development including the Coastside Design Review Committee (CDRC) which recommended denial of the design review permit for the proposed project, finding it fundamentally out of scale and out of character with the Princeton Community. The Staff Report and the project proponents have made a variety of assertions about the size of the project being in character with the built and natural environment of Princeton. However, to date these assertions have not been supported by the factual evidence necessary to draw such conclusions.

Attachment T

Big Wave 8-Building Alternative Executive Summary and Staff Report

January 14, 2015

Page 2

As a means of evaluating such size and scale claims, Commission staff estimated the building footprint square footage of all buildings in Princeton using Google Earth Pro which revealed the following:

- 91% (357/392) of all buildings have a building footprint less than 5,000 square feet
- 6% (24/392) of all buildings have a building footprint between 5,000 and 10,000 square feet
- 1% (4/392) of all buildings have a building footprint between 10,000 and 15,000 square feet
- 1.5% (6/392) of all buildings have a building footprint greater than 15,000 square feet
- All buildings in Princeton with a building footprint square footage greater than 10,000 square feet appear to be less than 30 feet in height except for the Harbor Village (91,522 square foot building footprint) which has a maximum height of 36 feet.

The proposed project would add 2 buildings with a building footprint between 10,000 and 15,000 square feet and 6 buildings with a building footprint greater than 15,000 square feet. The total square footage of the building footprint for all proposed buildings contained in the Big Wave 8-Building Alternative would be 126,845 square feet with heights between 30 and 34 square feet (building height from existing grade). Thus, from this analysis, it appears that this would be the largest development in terms of total building footprint with heights greater than 30 feet to ever be allowed in the Princeton Community. The only development close in size and height, Harbor Village, is a visitor-serving development located in a different zoning designation, which happens to also be a Coastal Act and LCP high priority use within the coastal zone. This data would suggest that the project is out of scale and character with the Princeton area, and would suggest that changes to reduce its scale would be appropriate. We recommend that the County consider this data, and consider project modifications that can bring the project into a size and scale that is consistent with the community and the vision for it moving forward. Please see Attachments 1 and 2 for the data collected from Google Earth Pro used in the above analysis.

In addition and related, LCP Policy 1.3 recognizes that some lands, including prime agricultural soils and sensitive habitats included in the urban boundary, should not be developed at relatively high densities. In the Staff Report, the County indicates that the project is not considered to be “relatively high density” development under the LCP based on an argument that density is defined by the number of proposed dwelling units, and none of the uses (including the 57-bedroom Wellness Center) are considered to be dwelling units because they lack kitchens. We do not believe that that is the correct way to understand this policy. Instead, it is clear to us that this policy refers to density as a matter of scale in a broader sense, including with respect to density of other types of development, such as industrial uses. The Coastal Act and the LCP are clearly protective of agriculture, whether the land in question is LCP-designated for agriculture or not, and this policy is the LCP’s expression of that protection. The agricultural land is not intended to simply be a blank slate within which whatever density the underlying zoning might support is automatically allowed. On the contrary, it is a constraint that affects the level of density that is appropriate, and the LCP at this location requires that the project not be relatively high density. From our analysis above, it appears that this is the most dense configuration of large buildings (in terms of building footprint square footage and height) to be proposed in the Princeton Area ever, and thus cannot be categorized as not “relatively high density” development. Again, this suggests that project modifications

Big Wave 8-Building Alternative Executive Summary and Staff Report

January 14, 2015

Page 3

designed to limit the density (and the size and scale more generally, see above) are warranted, and we recommend that the County consider reduced scale alternatives at this site that can better achieve LCP consistency on these points.

Furthermore, the LCP protects public views and requires visual compatibility otherwise. LCP Section 6565.17 (L) requires that “The design of the structure is appropriate to the use of the property and is in harmony with the shape, size and scale of adjacent buildings in the community.” As indicated above, it appears that the size, scale, and density of the proposed project is significantly larger than that found in the surrounding community. In addition, the visual aspects of the project have changed significantly, including building design, location, articulation, colors, spacing, massing and landscape screening, and we have only had limited time to review such materials. Commission staff recommends that the size, scale, and design be reevaluated for consistency with the surrounding community and public view protection. Again, it seems clear that a reduced scale project need to be considered for LCP consistency. Further, design measures to help reduce perceived scale (including breaking up the design with some areas of indent, varied rooflines, offsets, and projections that provide shadow patterns, a smaller second story set back from the first, etc.) should also be applied. In addition, as soon as the project proponent has reached a conclusion on what, exactly, they are proposing, then they need to produce a visual assessment of that project for public review, whether through a series of visual simulations or through the use of story poles and netting, or some combination, so that the interested parties can better evaluate the visual impacts of the final proposed project. The analysis provided thus far is insufficient in this regard.

Finally, it has been expressed by the Staff Report and the project proponents that this is the only scale of project that would be financially feasible. However, we are not aware of the documentation and analysis supporting such conclusion. As we previously requested, we believe it is critical that there be a clear analysis of financial feasibility for the project, including related to reduced scale alternatives that appear necessary to meet LCP requirements. Statements and conclusions lacking analysis and data are not helpful in this respect, and it does a great disservice to the public when a certain scale is considered the only starting point for evaluation based on same.

Concerns discussed above regarding the size, scale, and density of the proposed project and its consistency with surrounding development and community character have been expressed by Coastal Commission Staff, Committee for Green Foothills, and the Midcoast Community Council. In addition, the Coastside Design Review Committee recommended denial of the design review permit for the proposed project, finding it fundamentally out of scale and out of character with the Princeton Community. The analysis above quantitatively reflects that the proposed project is in fact inconsistent with the size, scale, and density of the surrounding community. We strongly recommend that the County reconsider the proposed project taking into account the above analysis and comments from the community and reduce the project to better meet the requirements of the LCP. Any such, consideration of reduced project alternatives should include evaluating reductions to the overall square footage and height of the of the project (including numbers of buildings), restricting taller structures to the area farthest away from the public road and public view, and stepping back second stories (if they are appropriate) from first stories along the street frontage, and other measures designed to ensure that any approved project is consistent with the size, scale, and character of the surrounding community.

2. Project Uses and Phasing: The length and nature of the project phasing and the undefined nature of the potential uses within the Office Park and Wellness Center business space have contributed to the overly complicated nature of this project, significant concerns expressed by the community, and extensive conditions included in the Staff Report necessary to ensure that future potential scenarios will not impact coastal resources. The County and the Applicant continue to assert that the maximum amount of development will be restricted by the total amount of approved parking and availability of public services such as water and wastewater treatment. However, the method of implementing such limitations is made complicated and difficult by the way in which the project phasing and uses have been structured. If the County continues to pursue an approval that allows project phasing and limitations based on water, sewer, and parking constraints, then the way in which the project is affected by such constraints needs to be better defined. In particular, once an appropriate overall size and scale is identified (see above discussion), then the degree to which different components can be developed and the way in which such components “use up” allowed development potential need to be clearly described. For example, if the site is developed in such a way as all of the parking, water, and/or sewer allocations are used up by something less than the number of buildings/square footage initially allowed for the overall project, then there needs to be a mechanism in the approval that then ensures that the rest of the project is no longer authorized, and that ensures that such remaining area is then restricted to open space. The Staff Report includes a condition akin to this, but it is structured to be evaluated at the end of a 15-year term. This is inappropriate. If the project uses up its level of intensity, then the restrictions on future development (including areas being changed from buildable to non-buildable open space) need to be initiated immediately instead of waiting until the end of the 15 year construction period.

Similarly, in terms of potential modifications to the project in the future, including the area of boat storage proposed for the south parcel, it is true that coastal permit amendments would be required. However, given the way in which the phasing and lack of exactness associated with the uses might play out, it is inappropriate to only rely on an amendment process to resolve such future issues. At a minimum, the permit should be conditioned so that any future potential changes are only allowed if they will not increase the size, scale, density, and intensity of use approved, will not increase coastal resource impacts, and will not otherwise lessen or avoid the intended effect of the terms and conditions of the permit.

Finally, the project phasing itself is still unclear as detailed in the Staff Report. The description of Phasing on Page 19 of the Staff Report indicates that all Wellness Center buildings will be built before the Office Park buildings. However, proposed Condition 73 and the Phasing Plan in Attachment K illustrate otherwise. Condition 73 indicates that the Office Park buildings on lots 2 and 3 can be built before the Wellness Center buildings 1 and 2. If the intent is to develop the Wellness Center component of the project first, which we believe is appropriate, then the project phasing needs to be further refined to ensure that that is the case.

3. Public Services: It is still unclear that the demand on public services for the proposed project has been adequately evaluated. Page 22 of the Staff Report states, “...the traffic report in the Final Addendum adequately evaluated traffic impacts from a mix of uses, including 84,000 square feet of office plus the Wellness Center.” Commission staff has reviewed the traffic report in the Final

Big Wave 8-Building Alternative Executive Summary and Staff Report

January 14, 2015

Page 5

Addendum and it appears that the estimated office use utilized in that analysis was only 64,505 square feet. In addition, the traffic report only examines intersections and does not look at the level of service for roadway segments. In further examination of other recent traffic studies conducted in the area for other proposed projects, Commission staff has found that these other studies concluded a higher level of service at intersections and on roadway segments (including the City of Half Moon Bay Highway 1 Traffic Safety Study by DKS Associates, dated December 6, 2011). The DKS report found that the intersection of Highway 1 and Highway 92 to operate at a LOS of E during Saturday midday peak hours, and LOS D during the weekday PM peak hours. The study also found that a majority of the roadway segments between Miramar Drive and Highway 92 along Highway 1 operate at LOS E during AM and PM peak hours and Saturday midday hours. This suggests that there are more severe roadway capacity constraints than what has been evaluated in the proposed project. The analysis of traffic impacts needs to clearly assess the manner in which the proposed project would affect traffic not just at intersections but along Highways 1 and 92 overall, including critically during summer peak months and weekends when coastal visitors are using these primary coastal access routes. In addition, to the degree the project results in worse traffic, these impacts need to be avoided, and/or appropriately mitigated if they can't be avoided. We note that the LCP identifies a range of potential mitigations in such cases. It does not appear that the project's traffic impacts have been fully addressed in a similar way.

4. Page 20 of the Staff Report states that the Montara Water and Sanitary District (MWSD) letter dated October 24, 2014 provides the comparative estimate data previously requested by Commission Staff. This data estimates a range of 3,000 gallons per day (gpd) for industrial uses and 8,300 gpd for institutional uses. It is not clear how many specific projects fall within those estimates. If the estimate is 3,000 gpd for one industrial use, and the project is proposing 5 new industrial uses, wouldn't the water estimate be 15,000 gpd for the office park only? Please provide clarity on this issue.

The County also discusses in the Staff Report that verification of available water to serve a project occurs during the building permit application process and if there is no water available, no building permit will be issued. We do not believe that this is appropriate under a coastal permit. The coastal permit should only authorize development that can and will be served by available water, and that should not be left to a future building permit assessment period that may be 5, 10, to 15 years down the line when circumstances may be different. Either the project has water or it doesn't, and to the degree it does, then it needs to be clearly maintained. If not, and if it is left to a future building permit assessment period, it is not clear to what degree such an assessment affects allowable development under the coastal permit, and the way in which the lack of water means that the project needs to be reduced (and the proposed approval lacks an implementation provision to require such reduction – see also discussion above about “using up” available allotments). The Applicant should be responsible for securing all the water necessary for the entire approved development.

Finally, given the lack of clarity over phasing and uses, it will be critical that all service constraints are analyzed for the ‘worst case’ scenario, and that that degree of service need is presumed for evaluation purposes.

Big Wave 8-Building Alternative Executive Summary and Staff Report

January 14, 2015

Page 6

5. **Other:** It appears that the parking lot planters are encroaching into the 150 foot wetlands buffer as shown in the proposed landscape plan. This is inconsistent with the protection of sensitive resources and the County conditions.

In closing, it is clear that there is the need for additional analysis, including critically in terms of evaluating reduced scale alternatives to meet LCP requirements. In addition, many aspects of the project have been rapidly changing, and there is a lack of precision associated with the proposal at this juncture. This is a significant project at a very large scale and scope. We encourage the County to take the time that is required to allow for the necessary analyses to occur and the necessary project materials to "catch up" to the permitting process. We believe that good planning and public policy dictate as much, and we look forward to additional coordination and discussion on the proposed project, including as new information and materials are developed moving through the County's CDP evaluation process. If you have any questions regarding these comments, please contact me at the address and phone number listed below.

Sincerely,

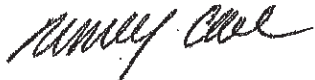

Nancy Cave
District Manager
California Coastal Commission
45 Fremont Street, Suite 2000
San Francisco, CA 94105
(415) 904-5290 Phone
(415) 904-5400 Fax
Nancy.Cave@coastal.ca.gov

cc: Scott Holmes, Applicant
Don Horsley, District 3 Supervisor
Midcoast Community Council
Committee for Green Foothills



County of San Mateo - Planning and Building Department

ATTACHMENT U

January 21, 2015

Jeff Peck
Big Wave LLC
P.O. Box 1901
El Granada, CA 94018

Dear Mr. Peck:

Subject: **LETTER OF DECISION**
File Number: PLN 2013-00451
Location: Airport Street in Princeton-by-the-Sea
APNs: 047-311-060 and 047-312-040

On January 14, 2015, the San Mateo County Planning Commission considered (1) the Certification of an Addendum to the Certified 2010 Big Wave Wellness Center and Office Park Project Draft Environmental Impact Report (EIR) and Final EIR (2010 EIR) for the Revised Big Wave North Parcel Alternative Project (Big Wave NPA Project), pursuant to the California Environmental Quality Act (CEQA); (2) a Use Permit, pursuant to Section 6500 of the Zoning Regulations, for the modern sanitarium component of the Wellness Center, outdoor parking uses in the Airport Overlay (AO) Zoning District, and an Outdoor Boat Storage Use; (3) a Major Subdivision, pursuant to the County Subdivision Regulations, of the north parcel into seven lots and the creation of up to 108, approximately 1,500 sq. ft., business condominium units; (4) a Minor Subdivision, pursuant to the County Subdivision Regulations, of the south parcel into two lots; (5) a Coastal Development Permit, pursuant to Section 6328.4 of the Zoning Regulations, appealable to the California Coastal Commission, for the proposed subdivisions, uses, and improvements; (6) a Design Review Permit, pursuant to Section 6565.3 of the Zoning Regulations, for proposed structures and associated grading; (7) a Grading Permit, pursuant to Section 8600 of the San Mateo County Ordinance Code, to perform 735 cubic yards (cy) of cut for utility trenching and to place 16,400 cy of imported gravel, and (8) a draft Development Agreement to allow project construction over 15 years. The project involves the development of the north parcel (APN 047-311-060) with an Office Park, including five buildings containing a total 162,000 sq. ft. of industrial/office/storage uses; a 3-building Wellness Center consisting of 70,500 sq. ft. of affordable housing and associated uses with a maximum of 57 bedrooms for a maximum of 50 developmentally disabled (DD) adults and 20 staff and 27,000 sq. ft. of industrial/office/storage uses; and a total of 554 private parking spaces, as well as the development of the south parcel (APN 047-312-040) with a boat storage lot and 92 coastal access public parking spaces, proposed on two undeveloped parcels.

With a vote of 4 in favor and 1 opposed (Commissioner Kersteen-Tucker), the Planning Commission made the following decisions:

1. Certified the Addendum to the Certified 2010 EIR



2. Approved a Use Permit for the modern sanitarium component of the Wellness Center, outdoor parking uses in the AO Zoning District, and an Outdoor Boat Storage Use;
3. Approved a Major Subdivision to subdivide the northern parcel into seven lots with up to 108 business condominium units and a Minor Subdivision to subdivide the southern parcel into two lots;
4. Approved a Coastal Development Permit, appealable to the California Coastal Commission;
5. Approved a Design Review Permit for proposed project structures and associated grading; and
6. Approved a Grading Permit to perform 735 cubic yards (cy) of cut for utility trenching and placement of 16,400 cy of imported gravel, by making the required findings, and subject to the conditions of approval, as revised during the meeting and listed in Attachment A; and
7. Recommended that the Board of Supervisors approve the draft Development Agreement, as revised during the meeting, to allow project construction in phases over a 15-year term.

Any interested party aggrieved by the determination of the Planning Commission has the right of appeal to the Board of Supervisors within ten (10) business days from such date of determination. The appeal period for this matter will end at 5:00 p.m. on January 29, 2015.

The approval of this project is appealable to the California Coastal Commission. Any aggrieved person may appeal this decision to the California Coastal Commission within 10 working days following the Coastal Commission's receipt of the notice of Final Local Decision. Please contact the Coastal Commission's North Central Coast District Office at 415/904-5260 for further information concerning the Commission's appeal process. The County and Coastal Commission appeal periods are sequential, not concurrent, and together total approximately one month. A project is considered approved when these appeal periods have expired and no appeals have been filed.

Please direct any questions regarding this matter to Camille Leung, Senior Planner, at 650/363-1826 or Email: cleung@smcgov.org. To provide feedback, please visit the Department's Customer Survey at the following link: <http://planning.smcgov.org/survey>.

Sincerely,

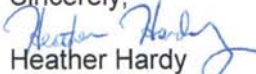

Heather Hardy
Planning Commission Secretary

HH:pac - HKHZ0089_WPN.DOCX

Attachment A: Findings and Conditions of Approval

cc: Department of Public Works
Building Inspection Section

Environmental Health Division
County Geologist
Coastside Fire Protection District
County Airports
Parks Department
City of Half Moon Bay
Local Agency Formation Commission
California Coastal Commission
Montara Water and Sanitary District
Granada Sanitary District
Midcoast Community Council
Committee for Green Foothills
Princeton Citizens Advisory
TRA Environmental Sciences
Surfrider Foundation
Sierra Club
League for Coastside Protection
Scott Holmes
David J. Byers
Stephen St. Marie

Note: Letter provided without attachments. See Attachment A for approved findings and conditions, including minor revisions to conditions shown in track changes format.