



Using Cognitive Responses to Assess and Improve Vehicle Brake Light Designs

Final Report

Prepared by

Investigators: Palaniappan Ramaswamy, Ian McLoughlin and Howard Bowman

Research Assistants: Surej Mouli and Evangelia Fringi

School of Computing, University of Kent

For ROAD SAFETY TRUST PROJECT RST 90_4_18

21 December 2020 (revised 6 July 2021)

Executive Summary

Over half of all road accidents are caused by either lack of driver attention or insufficient gap between vehicles, with collision from the rear being the most common cause in the UK. Yet these accidents should be among the most avoidable since brake lights are designed to clearly indicate to a following driver that a vehicle is slowing down or stopping.

Brake lamps historically used incandescent bulbs, but LEDs are attractive to manufacturers and are becoming increasingly common. Vehicles are increasingly being fitted with unusual and interesting shapes and patterns for their brake lamps. However very little research has been conducted to date on assessing the effectiveness of brake light design, and almost none have considered the effect on brain perception. Since a brake light must be noticed before it can be acted upon, and with so many accidents caused by inattention, the perception of new light designs is an extremely important and timely study, which this research has addressed.

The aim of the research project was to therefore evaluate the effectiveness of existing vehicle brake light designs in particular comparing conventional bulb and recent LED based brake lights. This research also provided an augmented method for evaluating brake light efficacy, taking into account not only the braking time latencies that a pair of brake lights can elicit, but also the time latencies of the event-related potentials that are perceptually evoked in the brain signal of a driver.

The experimental study required electroencephalogram (EEG) data collection, time stamps for brake light turning on events, and time stamps for brake pedal press events. To meet these requirements, we developed a custom hardware platform with multiple event marker generation using a 32-bit microcontroller. A driving environment was simulated using a video projected behind the brake lights. For the simulation of brake lights, the ten different brake lights were fitted (two 23 from conventional bulb and eight from LED, one at a time) on two adjustable stands to model the actual horizontal distances in cars. EEG data was measured from channel Pz (an area of brain which is known to be involved in decision making).

Each session was designed as a simulated driving paradigm with the brake light assembly in front of the participant representing a leading vehicle. Those brake lights were activated at random intervals. Subjects were instructed to continuously depress the accelerator pedal until they perceived an activation of the brake light in the simulated leading vehicle. At that point they were told to immediately release the accelerator and depress the brake pedal. Data was recorded from a total of 22 volunteers. All possessed valid UK driving licenses and had normal or corrected-to-normal vision. Half of the subjects were classed as experienced drivers, with more than four years of driving experience. Ethics approval for all experiments were obtained from the Faculty of Science Research Ethics committee at the University of Kent.

The first data analysis was based on reaction time latencies evoked by the different brake lights, while the second data analysis was based on brain responses (known as P3) evoked by the different brake lights simulation. Timing results indicate that versions of brake lights containing incandescent bulbs were slower than all the eight LED lights (and this result was statistically significant). It is known that bulbs taken longer to light up (for example, there is usually no discernible light output until up to about 50 ms, after power is applied) but the cognitive reaction time delay was about 170 ms when comparing a bulb and its LED equivalent, which

shows that LEDs have the ability to evoke brain responses quicker. Within LED, there were differences statistically as detailed further in the final report.

Comparing the age of participants, it did not show any difference, but driving experience mattered. An unique approach for the timing analysis was used to identify the cognitive response after seeing the brake light and lifting the foot from the accelerator which would assist in understanding the influence of cognitive action component of raising the accelerator pedal after seeing the brake light. This analysis showed that at the slow end of the reaction time, inexperienced participants are especially slow. Given that hazard perception test is now commonly included for learner drivers, it is recommended to increase the amount of training in this regard to enable quicker cognitive perception. EEG analysis showed statistical differences in latencies from different brake lights. The bulbs were statistically slower than LED. Within LED lights though, EEG analysis did not clearly indicate difference which could be due to noise being present in the brain signals and implementing advanced noise reduction methods may reveal differences similar to timing analysis.

In conclusion, although the subject pool was small and real-road traffic conditions were not tested, the strong statistical difference between LED and bulb based brake lights for every tested participant with both timing and cognitive responses, show that LED based brake lights have a clear advantage in their effectiveness to draw quicker response from participants and it is our recommendation that bulb based brake lights should be phased out.

Contents

1	Introduction	1
2	Background	1
3	Methodology	9
3.1	Aim and Objectives	9
3.2	Methodology	10
3.3	Experimental Hardware	10
3.4	Experimental Setup	11
3.5	Experimental Protocol	13
4	Timing Analysis	14
4.1	Results (Timing Analysis)	14
4.2	Conclusion (Timing Analysis)	23
4.3	EEG Analysis	24
4.4	Results (EEG Analysis)	25
4.5	Conclusion (EEG Analysis)	28
4.6	Final conclusion from WP2	29
5	Future Directions	29
5.1	WP3 Suggestions	29
5.1.1	Hardware prototype and firmware development	30
5.1.2	EEG hardware and electrode setup	32
5.1.3	Data acquisition	32
5.1.4	Data analysis	33
5.2	WP4 Suggestions	33
6	Contributions	33
7	Final Conclusion	35

1 Introduction

Recent reports from the World Health Organization (WHO) have highlighted a rise in reported road traffic accidents, reaching 1.35 million in 2016 [1]. According to the National Highway Traffic Safety Administration, rear-end crashes accounted for 33.4% of the total crashes in the USA in 2015 [2]. Department for Transport (DfT) statistics in the UK report that there were 13,374 slowing or stopping car accidents in 2017 [3]. Fig 1 shows the accidents involving car occupants reported in 2019, which accounts for 43% of total fatalities according to the annual report published by DfT [4].

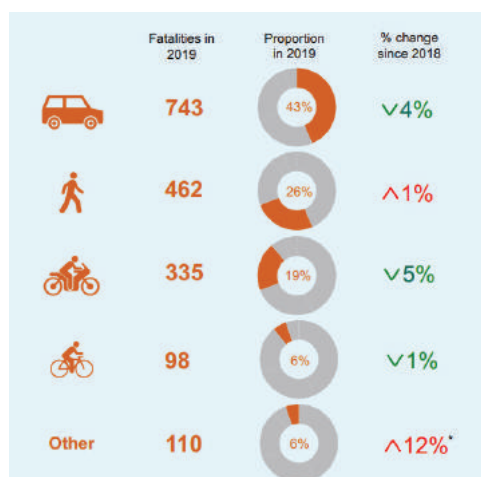

Figure 1: Reported road casualties in 2019 in UK ([4])

The major causal factor of rear-end collisions occurs when a following driver does not react correctly to the behaviour of the leading vehicle due to inadequate or late detection of leading vehicle deceleration. Many research studies have examined different ways of alerting drivers to avoid rear-end crashes by improving technology either inside or outside the driver’s vehicle [5–10].

2 Background

A driving simulation study by Li and Milgram (2008) used a dynamic brake light system, which used the concept of ‘optical looming’ from which the luminance continuously and gradually expands outwards from the brake light enclosure as shown in Figure 2 [9]. This manipulation helped participating drivers brake sooner when the lead vehicle’s lights were positioned further apart, while expanding in luminance improved operating in low visibility conditions.

The effectiveness of a Graded Deceleration Display (GDD) at reducing rear-end collisions was investigated by Stanton et al. in which a rear centre high mounted stop lamp was replaced with a graded illumination that changed size to match the deceleration. This produced more accurate behavioural responses during deceleration, reduced collisions and also encouraged a safer following distance from the leading vehicle than the traditional

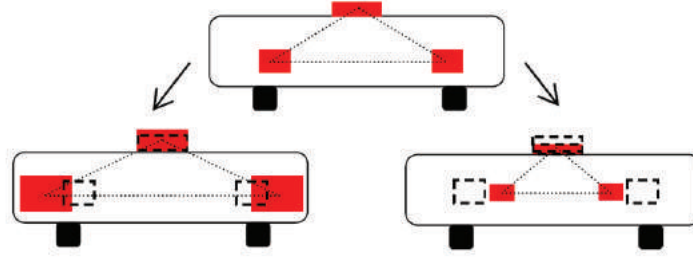

Figure 2: Optical Looming concept – Top represents normal brake light pattern, bottom left illustrates the expanded brake light pattern and bottom right the contracted brake light pattern

binary brake light system (Fig. 3) [11]. GDD elicited more accurate deceleration information that drivers could follow, and gauge the deceleration change from the lead vehicle.



Figure 3: Graded Deceleration Display

An imminent warning rear light concept was explored by Weirwille et al. (2006) in a real-world study, which intended directing the following drivers' visual glance to the lead vehicle as it brakes rapidly to stop or slow down [12]. The system was developed using a high-intensity narrow beam that passes over the face of the following driver when the lead vehicle brakes. Results showed improvements of 0.25 to 0.35s in brake activation times when compared to traditional rear lighting.

A 100-car naturalistic driving study (real-world study) conducted by Virginia Tech Transportation Institute and National Highway Traffic Safety Administration, USA discovered nearly 80% of all crashes and 65% of near-crashes involved lack of driver attention prior to (within 3 seconds) the onset of the event [13]. The investigation included 109 primary drivers for a period of 13 months, collecting 42,300 hours of driving data [14]. Data analysed from driver attention revealed visual attention was a contributing factor for 93% of rear-end striking crashes. Driver distraction duration was also a major cause of the increase in reaction time, with other factors having indirect effects mediated by dis-

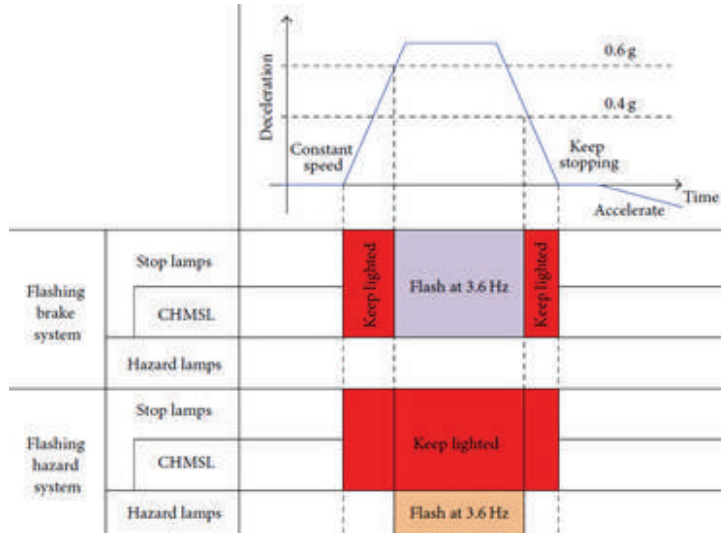

Figure 4: Enhanced flashing system

traction duration. Unsurprisingly, they found that engaging in an auditory-visual-manual secondary task tended to result in longer reaction times [6].

A majority of the brake light modification suggestions are based on the landmark field study (real-world study) conducted in 1974 using a fleet of San Francisco taxi cabs, where a number of the fleet were equipped with a deceleration warning light system, centre mounted on the rear of the vehicle [15]. The warning light was activated using the brake pedal and pulsed at a rate that increased exponentially with the increase in gravity force generated by the deceleration. Studies conducted over a 12-month period saw a decrease in the rear-end collision rate, from 8.91 collisions per million miles over a total of 7.2 million miles for the control group without the warning light, to 3.51 collisions per million miles over a total of 12.3 million miles for those fitted with the warning light. Later, this concept was tested on a larger scale by the U.S. National Highway Traffic Safety Administration by modifying the flashing light to become a spot light termed a centre high mounted stop light (CHMSL). Since 1986, a CHMSL has been standard safety equipment on all new passenger cars in the USA. In the US, most cars have red turn signals and it is not compulsory to have amber turn signals, as such CHMSL would be advantageous in such cases. Most developed countries have also made CHMSL mandatory, for example in Europe since 1998 based on UN regulation 48.

While CHMSLs are effective, they do not relay information to the following driver on the intensity of braking in the lead car. Even though the initial evaluation suggested a 50% reduction in relevant rear-end collisions in the vehicle with CHMSLs, the reality is that its effectiveness has decreased around 4.3% over time [16].

Studies have also explored various lamp types that are used for stop lamps [17–19]. Reaction time varies by the type of lamp used for brake lights. Popular automotive stop lamp types are incandescent, sweeping neon and LED. Bullough et al. evaluated the three variants of automotive stop lamps used for CHMSLs (incandescent, LED and neon), finding that incandescent lamps had the highest reaction time compared to the others. This may be because incandescent lamps do not emit measurable light until about 50ms

after activation, and take around 250ms to reach 90% of their steady state brightness [20]. An LED CHMSL, compared to neon, has a shorter reaction time, probably because an LED consists of a high-luminance point source that can provide a stronger stimulus than the more diffuse neon lamp [18].

The effectiveness of flashing brake and hazard systems in avoiding rear-end crashes was investigated in a driving simulator study which revealed that this reduced the driver’s brake response time by between 0.14 and 0.62s for the various situations tested [8]. To put this in context, if a driver’s response time could be reduced by 0.2s, the stopping distance can be reduced by approximately 4.4m for an initial velocity of 80km/h and deceleration of 0.8g.

The experimental design had two enhanced flashing systems, as shown in Fig 4. For the flashing brake system, both the stop lamps and the CHMSL were illuminated when the lead vehicle started to decelerate. When the vehicle’s deceleration first exceeded 0.6g, both sets of lamps would be triggered to flash at 3.6Hz until the deceleration of the lead vehicle was less than 0.4g. The flashing duty-cycle (proportion of on-time) was set to 50%. The selection of frequency at 3.6 Hz could be due to studies on distraction that have reported the existence of theta oscillations in the frontal lobes that relates to cognitive control, i.e. being focused or not on the current task [21].

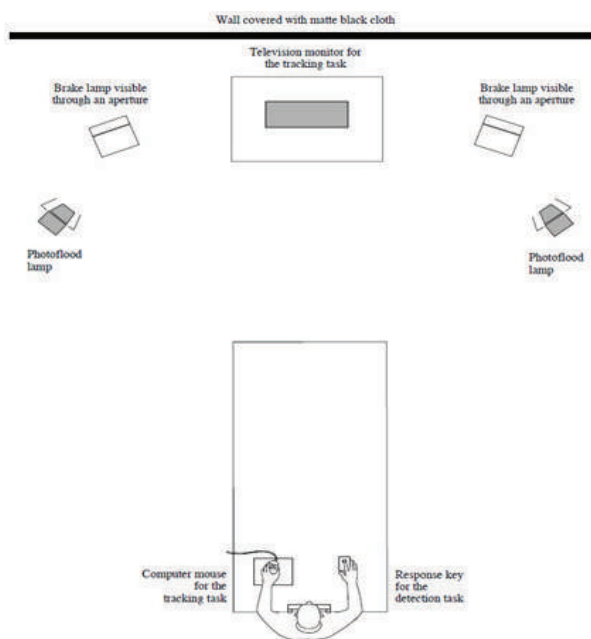

Figure 5: Experimental setup by Sivak et al., 1994 [19]

Sivak et al. evaluated the reaction times for incandescent, fast incandescent lamp, neon and LED lamps using simulation [19]. To enhance the reaction time for the incandescent lamps and to make the reaction time less, the researchers created a ‘fast incandescent lamp’. This involved connecting a standard incandescent lamp to a constant power source that continuously applied a low voltage to the bulb filament to keep it active but just below a visible intensity, then delivering a brief overvoltage at the time of brake activation. This process would reduce the time taken for the lamp to reach a visible or steady-state output, thus reducing the response time. In the experimental

Table 1: Mean reaction time by lamp

Lamp	Mean reaction time (<i>ms</i>)
Standard incandescent	662
Fast Incandescent	527
LED	503
Neon	489

study, subjects performed two concurrent tasks. The first was to press a response button as soon as either of two brake lamps was turned on. The lamp was turned off as soon as the response was made, so the subject received immediate feedback. The second task was to control a compensatory tracking task designed to approximate the perpetual and motor work load of driving. The tracking task was a dynamically simulated road scene on a computer-driven monitor, and the subject’s task was to keep the road centred on the monitor. The experimental setup is shown in Fig 5, where the subject sat 4m from a 27” television monitor that displayed the tracking task. Subjects moved a computer mouse left or right with their left hand to control the driving task. They used their right index finger to press a response button when either brake lamp was energised. Eye position was kept approximately constant across subjects by having them place their chins in a chin rest at a fixed position. The brake lamps were positioned to either side of the tracking task monitor such that the visual angle from the centre of either lamp to the centre of the monitor was 20°. Incandescent photoflood lamps were placed on each side of the table to illuminate the face of the brake lamps at approximately 5,500lx to simulate daytime driving conditions. Sixteen subjects participated in the study, and the reaction times for all the lamp types are shown in Table 1. The neon, LED and the fast-incandescent lamps yielded faster reaction times than the standard incandescent lamp while LED and neon yielded faster reaction times than the fast-incandescent lamp. The difference between LED and neon reaction time was not statistically significant.

A majority of traffic safety studies have used driver’s reaction time (RT), which is a concept that traffic safety researchers have repeatedly made use of in various models when designing experimental studies and analysing driver behaviour close to crashes [22]. The RT usually represents the time duration from the appearance of a potential hazard, such as a lead vehicle’s brake lights activating, until the driver initiates some form of evasive response (Society of Automotive Engineers, 2015). Considering the braking responses, the effectiveness has been traditionally measured using the brake reaction times (BRTs) with the influential factors being driver’s age, gender, cognitive load and various stimuli that the driver needs to consider [23–25].

An EEG based study to explore the impact of an auditory secondary task on drivers’ mental states during a primary driving task reveals that brake reaction times increases significantly while driving with an auditory secondary task as opposed to driving without one [26]. This study comprised 25 participants and was conducted on a non-public test track in an unused military training area in Germany. Participants were instructed to always prioritise the primary task and to drive in accordance with official traffic regulations around three loops of a 37km test track. The setup consisted of two cars; the lead car was navigated by an investigator, and the following car was driven by the participant. The participant’s car was instructed to follow the lead car at a constant distance of approximately 20m at a maximum speed of 60km/h. Fig 6 shows the test procedure

for the experiment.

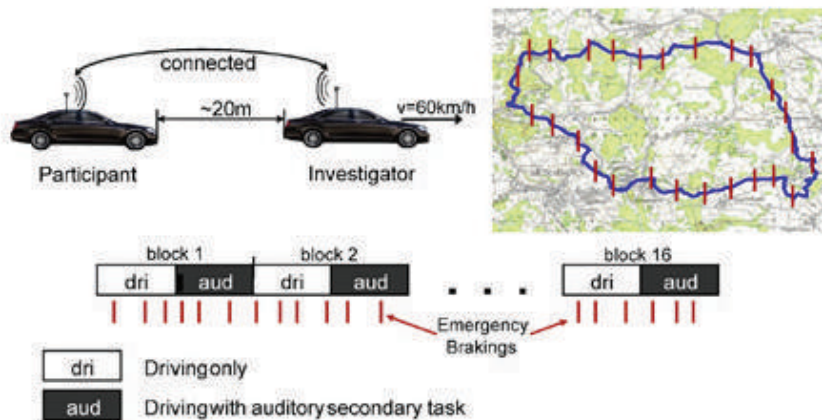

Figure 6: Test procedure of the car following task (Sonnleitner et al., 2014) [26]

The data collected in the experiment was from a 32 electrode-cap from ActiCap. A set of 25 electrodes was positioned according to the international 10-20 system. Muscle activity from the right foot was measured with two electrodes, positioned at the right musculus tibialis anterior and on the right thigh. The eye movements for the horizontal and vertical motions were measured using four electrodes positioned about 2cm above and below the right and left eye and right outer canthi. An ECG was recorded with one electrode above the cardiac apex. Before commencing the experimental data collection, all participants completed a supervised baseline where ocular artefacts were recorded to train a method for online eye blink artefact correction. This study identified a significant increase in brake reaction times, EMG reaction times and alpha spindles, for driving with an auditory secondary task, compared to driving without a secondary task.

Detection of braking intention in diverse situations based on EEG feature combination was explored by [27] using simulated driving. They were able to identify a broad range of possible emergency situations and could distinguish the sudden stop of a preceding vehicle, sudden cutting-in of a vehicle from the side and the unexpected appearance of a pedestrian [27]. Fifteen individuals participated in that study using a virtual driving environment displayed on a screen, simulating an urban neighbourhood without traffic lights, with autonomous vehicles and a vehicle to be steered by the participant. The participants' task was to drive a virtual vehicle using the accelerator, brake pedals and steering wheel; the virtual vehicle was equipped with a virtual automatic transmission. Three kinds of braking situations were studied based on braking intensity, and for an emergency braking situation. When participants depressed the brake pedal sharply, this was termed sharp braking, but when they performed spontaneous braking to decrease the vehicle's speed gradually, this was termed as soft braking. Finally, in various situations, participants did not need to decrease the speed of their vehicle, for example in a normal driving situation when a faraway vehicle braked abruptly and they did not require a corresponding change of speed, this was termed as no braking. For all the stimuli, the inter-stimulus interval was between 4 and 18s and drawn randomly from a uniform distribution as shown in Fig 7. For analysis, EEG signals were recorded using a multi-channel

EEG acquisition system from 64 scalp sites based on the international 10-20 system with actiCAP hardware. EMG signals were acquired using a unipolar montage at the tibialis anterior muscle. The EEG and EMG data were amplified and digitised using BrainAmp hardware.

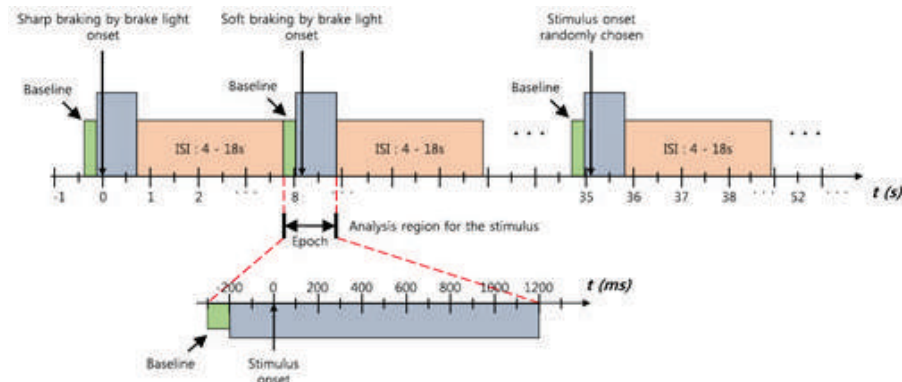

Figure 7: Timing scheme for the experimental paradigm (Kim et al., 2014) [27]

This study based prediction system used only EEG based feature combination, and could robustly classify the braking intention in all of the simulated traffic situations. It could demonstrate the possibility of better prediction of emergencies by detecting the braking intention of the driver in several types of driving conditions.

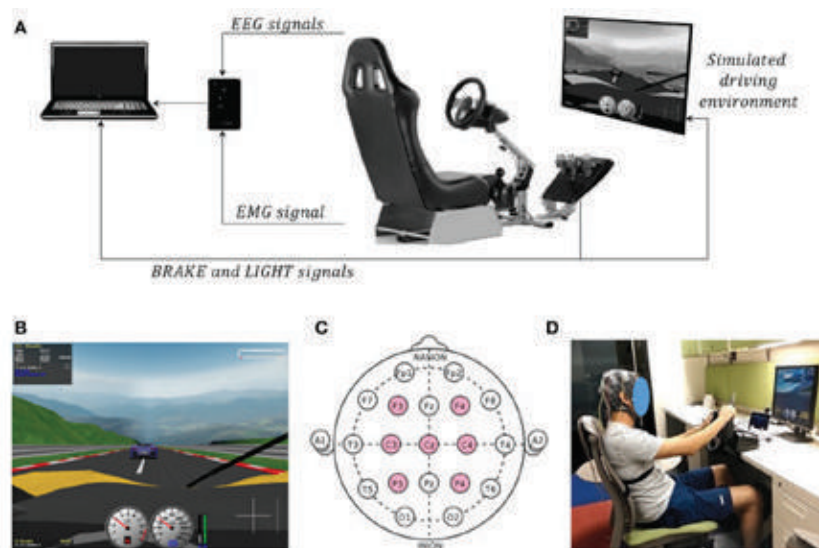

Figure 8: Virtual driving environment (Hernández et al., 2018) [28]

Investigation on detection of braking intentions under different car driving conditions was also explored by [28] using EEG. The study showed the feasibility of incorporating recognisable driver bioelectrical responses into advanced driver-assistance systems to carry out early detection of emergency braking situations, which could be useful to reduce accidents [28]. Their experimental platform consisted of a simulated driving environment as shown in Fig 8. EEG and EMG activity were recorded during execution of the experiment using an 8-channel wearable device using the 10/20 international system for EEG. EMG signals were recorded from the anterior tibial muscle from the right leg using a

monopolar montage. Participants were seated, and the experimental task was to drive the participant's vehicle while following the guide vehicle at a constant and fixed distance of 10m. The guide vehicle was driven autonomously at a constant speed of 100km/h and performed unexpected and sudden speed reduction of 60km/h. The braking actions were accompanied by the switching-on of the rear brake lights, providing a visual stimulus to the participants who were asked to avoid any collision by applying the brake pedal. After 3s, the guide vehicle would accelerate gradually again until it reached 100 km/h. During the execution of the experiments, participants were exposed to different combinations of the absence or presence of stress, workload and fatigue.

The collected data was analysed for brake reaction times for each emergency braking situation simply as the difference between the response time and stimulus time. The results showed the feasibility of using EEG to recognise an intention to perform emergency braking in driving conditions where the drivers experience realistic cognitive states including stress, workload and fatigue.

Up to now, investigations on brake light effectiveness have used the brake reaction time (BRT) metric. Drivers react differently in various situations; slower at lower speeds, faster in a real emergency, and their response is affected by issues such as driver height, shoe design, pedal location, seat placement, etc. To decouple those environmental effects from the influence of brake design, it is necessary to separately measure how quickly the driver perceives the brake signal, and then how quickly s/he responds to it.

The influence of visual perception is very important in the detection of brake lights and to minimise the reaction time. To explore this further, the existing vehicle brake lights need to be assessed in terms of their ability to evoke the necessary response or awareness from drivers. Eye tracking technology has also been used to study the effectiveness of brake lights, but suffers from spontaneous responses of the vision system that do not involve cognitive perception [29] (e.g. when an eye glances across a brake light but the driver is still not aware that it has activated).

Brain signals measured by EEG are more appropriate than reaction times, given that any signal must be firstly recognised by the brain, before a reaction can be made. It is generally known that there is a specific component in the EEG called P3b that "reflects a process that mediates between perceptual analysis and response initiation". In our case, this 'cognitive' component would relate to the recognition (i.e. awareness) of the brake light, which would then be translated as appropriate into braking action. The visual/perceptual components in EEG (known as N1-P1, which occurs earlier than the P3b by around 100ms) is related to the perception of the visual stimulus only, so a distraction (such as a dazzling brake light) will increase this component but not necessarily result in increased P3b (i.e. not necessarily in better recognition of the brake light). The influence of LED visual stimulus brightness was also confirmed by our previous research, where we compared the stimulus effect of different levels of LED brightness [30]. The study investigated the brain responses by evoking steady state visual evoked potentials using LED visual stimuli at brightness levels of 25, 50, 75 and 100% of maximum for a particular light. EEG recordings from five participants over five trials for different luminosity levels were analysed, the results indicated a luminosity of 75% of the full brightness gave a significantly higher response for all participants when compared to other levels, but with

reduced visual fatigue. The orientation of the light is also an influential factor for early detection of warning lights. Studies on brain responses from visual stimuli using horizontal and vertical orientated LED arrays shows higher brain responses for visual stimuli in a horizontal orientation than in a vertical orientation [31]. LED arrays in horizontally and vertically orientations were used as visual stimuli, and EEG was recorded from participants, and the differences in the responses were found to be statistically significant. In addition to the measured response efficiency of the horizontal orientation, participants reported that they subjectively felt a horizontal layout to be visually comfortable than a vertical one.

Automotive stop lamps have traditionally been based on incandescent lamps, which require approximately 85ms to reach 95% of full light output when power is applied [32]. This delay causes an increase in reaction time for the following vehicle driver to apply their brakes in an emergency. The delay could be mitigated with LED based stop lamps, which can be customised in shape according to the requirement of a manufacturer.

The first LED lamp was created in 1969 and since had seen a continuous improvement in design, ability to generate various colours, luminance, shape and power efficiency. This has resulted in LEDs becoming a better choice for lighting applications in the car industry than traditional bulbs. The main advantages of LEDs are as follows [33, 34]:

- Light up to maximum intensity quickly, improving the reaction time for the following vehicle driver to apply brakes;
- LED light sources can improve recognition response times associated with vehicle braking compared with incandescent bulb lights;
- LEDs can more efficiently generate light of appropriate saturated colour than filtered incandescent lamps;
- LED-enhanced brake signal lights can produce optimum flash frequencies as compared to incandescent lamps;
- Directional light capabilities allow the lights to produce focused rays;
- Being a semiconductor with no wear-and-tear parts, the life span is improved.

NHTSA investigated the crash-reduction benefits of LED brake lights and CHMSL and compared the crash rates for models of car which changed to LEDs from incandescent bulbs before and after the change [35]. The analysis showed a significant overall 3.6% reduction in rear-impact crashes with LED brake lamps. Those stop-lamps also had the advantage of high reliability, high and adjustable brightness, custom shapes and multi-functional ability.

3 Methodology

3.1 Aim and Objectives

The aim of the project is to evaluate the effectiveness of existing vehicle brake light designs, and identify factors that promote faster perception of the braking event. With this aim, the objectives are:

1. To develop electroencephalogram (EEG) response protocols and measurement algorithms that correctly represent visual stimuli recognition from LED brake light designs;
2. To evaluate existing LED brake light designs using the measure developed from objective 1;
3. To validate their performance under real driving conditions;
4. To analyse the differences in EEG (from objectives 2 and 3) between experienced and novice drivers to better understand the influence of experience in the braking response;
5. To publish LED brake design characteristic factors that promote faster driver perception, allowing manufacturers to develop new LED designs in future that are safer;

Although the study could involve any vehicle, we limit the scope to assessing brake light designs from cars. With the above aim and objectives, there are five workplans:

- WP1: Literature review
- WP2: EEG collection and analysis from existing LED based brake light designs
- WP3: Real life EEG data collection and analysis
- WP4: Improved LED brake light pattern design
- WP5: Directions for future work (academic collaboration and commercial exploitation)

As we will explain in later sections, due to the restructuring at University of Kent which caused a major shortage of staffing for the project and due to the Covid pandemic which cause a failure to obtain the necessary ethics for WP3, we have had to stop the project at WP2. This report presents our work for WP1 and WP2 but also our planned work packages for WP3 and WP4. We are hoping that interested parties would be able to pick up where we have left and continue the work - we would be pleased to work with any such like minded researchers. To this end, we have also uploaded the anonymised dataset that may encourage more work in this area.

3.2 Methodology

Experimental hardware and software were constructed to present random brake light events to subjects in a simulated setting, while recording the EEG and responses from a number of associated sensors. The experimental data was recorded in a quiet room of size 7.12×14.96 m with a projection screen at one end sized 5.00×3.75 m for replaying a highway traffic simulation video. Participants for the experiment were seated in an automotive-style chair at a distance of 5 m facing the screen as shown in Figure 9. Height and gap between brake lights was designed from averaged physical layout of cars.

3.3 Experimental Hardware

Experimental stimulator hardware was designed using a custom 32-bit microcontroller system [36] connected to the pedal switch sensors and two sets of MOSFET driver circuits as shown in Figure 10. Maximum turn-on delay for the MOSFET was negligible

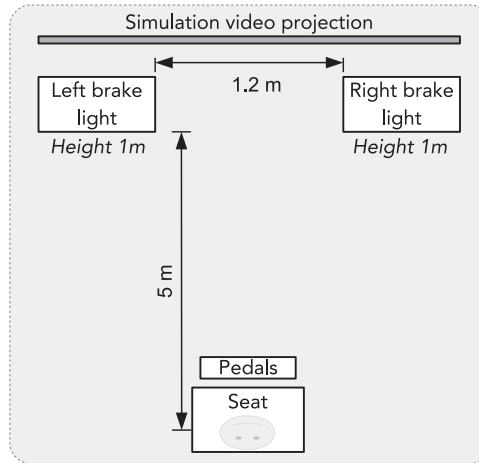

Figure 9: Physical layout of the simulation experiments

at only 55 ns. One set of MOSFETs was used to drive the brake lights and the other was used for activating two yellow circular rings which were deployed as a distractor. The firmware for the system was developed to generating brake light events randomly, while the yellow distractor rings were also illuminated at random intervals, more frequently than the brake lights, but not simultaneously.

The yellow ring was included to improve the elicitation of the P3 component and to minimise the expectation of the brake light, the yellow rings were introduced to flash randomly when the brake lights were not activated (the firmware was developed to flash only one set of light at any instance - both the brake lights and the distractor yellow rings were activated with random ON times). This also minimised the situation that the participants directly stare at the brake lights waiting for them to light up, which would not occur in reality. With the introduction of random flashes generated by the 100mm diameter yellow rings to distract the attention of the participants, the brake light stimulation introduced more unpredictability, as it would in a real-world situation.

An event recorder captured all of the timestamped signal information for later analysis. The collected information consisted of time-stamped brake activation, as well as times from the two foot pedal switches. Further details on the hardware can be found from the project website (<https://brake-light.uk>) and in Appendix C.

3.4 Experimental Setup

Volunteers were seated in an automotive style car, with an accelerator and brake foot pedal assembly (QLOUNI Industrial Foot-switch Momentary Metal Foot Pedal, part number: 611702431551), mounted in front of the seat as shown in Figure 9. The custom stimulator hardware was programmed to generate 45 brake light events to turn on (and then off) the brake lights, and similarly to activate the 100 mm diameter yellow distractor rings in random order. Brake light activation occurred at random times, and for random periods of between 2 to 4 s, with the distractor activation being at random times, illuminated for between 3 and 5 s each time, with the constraint that the distractors and brake

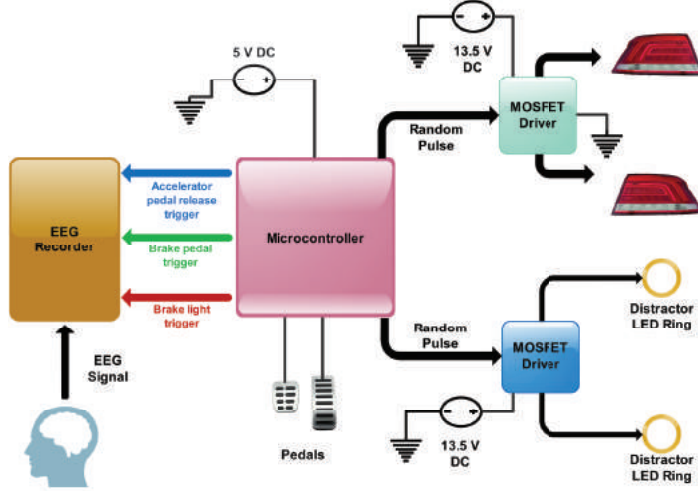

Figure 10: Brake light stimulator hardware design blocks.

lights were not activated simultaneously. EEG was recorded using OPENBCI hardware kit with eight channels based on the international 10/20 standard at locations F3, Fz, F4, C3, Cz, C4, Pz and Oz, although only channel Pz is used in the analysis here.

Ten sets of physical brake light assemblies from different car manufacturers, selected to represent a range of distinct light shapes from common models, were used in the experiments. Table 2 lists the part numbers of the assembly units and bulbs while Figure 11 shows one of the light pairs mounted for this study. Figure 11(a) shows the distractor rings when illuminated, while Figure 11(b) shows the activated brake light.

Table 2: Details of brake light assemblies used in the experiments

Manufacturer	Vehicle	Part number	Bulb type
Ford (Bulb)	Focus (2018)	1825320	Red 1490659
		1825318	
Fiat (Bulb)	Fiat 500 (2007)	OEN 52007424	OSRAMTAIL B001497
		OEN 52007422	
Audi (LED)	Q5 (2016)	8R0945093C	Audi-LED
		8R0945094C	
Fiat (LED)	Fiat 500 (2007)	OEN 52007424	82CRCANR-1
		OEN 52007422	
Ford (LED)	Focus (2017)	1825320	82CRCANR-1
		1825318	
Honda (LED)	Civic (2015)	ULT514226	PY21W LED
		ULT514202	
Mercedes (LED)	CLS-218 (2015)	OEN A2189067800	Benz-LED
		OEN A2189067700	
Alfa Romeo (LED)	Mito (2019)	LL0604	LED P21W
		LL0605	
Nissan (LED)	Leaf (2010)	OEN 265503NL0A	Nissan-LED
		OEN 265553NL0A	
Volkswagen (LED)	Golf (2017)	5G0945208C	VW-LED
		5G0945207C	

Eight of the light assemblies contained LED sources, while the remaining two employed incandescent bulbs. In order to make the LED/bulb comparison fairer, we included two same-vehicle model assemblies with different bulb types. Specifically, these were two sets of Ford Focus hatchback and Fiat 500 units. For both models, we tested one pair of lights that contained incandescent bulbs and another set that used LED sources, but were otherwise identical in size and shape.

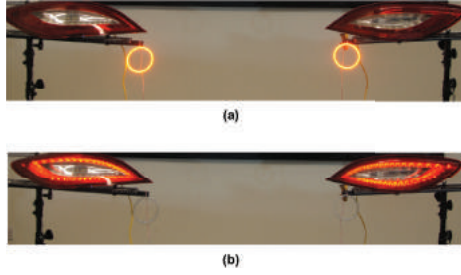

Figure 11: Experimental design: (a) Yellow distractor ring with unlit Mercedes brake light (b) Mercedes brake light activated and distractor rings unlit.

3.5 Experimental Protocol

The particular brake light unit pair under test were fitted to the mounts, aligned and tested before experimental subject were seated as shown in Figure 9. All experiments were conducted in daylight. A motorway (UK highway) video was projected on the screen, accompanied by the natural traffic and vehicle sounds as recorded – including tyre, engine and wind noise from the interior of the simulation vehicle as well as from passing vehicles. Subjects were given a task during the test, with the aim of keeping their attention focused on the road. Specifically, they were asked to keep count of the number of times brake lights were illuminated by other vehicles during the session.

Each session was designed as a simulated driving paradigm with the brake light assembly in front of the participant representing the *leading vehicle*. Those brake lights were activated at random intervals as noted above. Subjects were instructed to continuously depress the accelerator pedal until they perceived an activation of the brake light in the simulated leading vehicle. At that point they were told to immediately release the accelerator and depress the brake pedal. They were asked to ignore any flashes or activations of the yellow distractor rings.

The experiment consisted of two sessions, taking place on separate days, each evaluating the efficacy of five different brake light configurations. The sequence in which the lights were presentation to subjects within sessions was randomised.

Data was recorded from a total of 22 volunteers (age 27.4 ± 5.9 years, gender balanced). All possessed valid UK driving licenses and had normal or corrected-to-normal vision. Half of the subjects were classed as experienced drivers, with more than four years of driving experience. All volunteers were naive to the study and recruited from the local area, and were compensated with £100 (£50 for each session) in gift vouchers for their time. Ethics approval for the protocol was obtained in advance from the University of Kent Faculty of Science Research Ethics committee. We asked subjects to participate in the study only if they were alert and monitored the subjects during experiments and found that all subjects completed every opportunity of braking, i.e. not a single event was missed thereby indicating that the subjects were alert.

Table 3: Mean latency and standard deviation (*BrakeAcc*, *AccPdl*, in seconds) for each brake light from all subjects

Subject	Bulb		LED							
	Ford	Fiat	Audi	Fiat	Ford	Honda	Mercedes	Alfa Romeo	Nissan	Volkswagen
Experienced	0.61 ± 0.17	0.59 ± 0.15	0.45 ± 0.08	0.45 ± 0.10	0.44 ± 0.09	0.44 ± 0.08	0.46 ± 0.08	0.45 ± 0.08	0.44 ± 0.08	0.47 ± 0.11
Inexperienced	0.63 ± 0.16	0.60 ± 0.17	0.48 ± 0.15	0.49 ± 0.11	0.46 ± 0.12	0.48 ± 0.17	0.51 ± 0.14	0.50 ± 0.18	0.49 ± 0.11	0.51 ± 0.15
All subjects	0.62 ± 0.16	0.60 ± 0.16	0.46 ± 0.12	0.47 ± 0.10	0.45 ± 0.11	0.46 ± 0.13	0.48 ± 0.12	0.48 ± 0.14	0.46 ± 0.10	0.49 ± 0.13
Subject	<i>AccPdl</i>									
Experienced	0.35 ± 0.14	0.34 ± 0.11	0.33 ± 0.12	0.32 ± 0.11	0.33 ± 0.10	0.33 ± 0.12	0.32 ± 0.12	0.32 ± 0.11	0.33 ± 0.11	0.32 ± 0.12
Inexperienced	0.35 ± 0.13	0.33 ± 0.17	0.31 ± 0.11	0.34 ± 0.12	0.32 ± 0.13	0.33 ± 0.15	0.33 ± 0.11	0.32 ± 0.16	0.32 ± 0.13	0.34 ± 0.12
All subjects	0.35 ± 0.13	0.33 ± 0.15	0.32 ± 0.11	0.33 ± 0.12	0.33 ± 0.11	0.33 ± 0.14	0.33 ± 0.11	0.32 ± 0.14	0.33 ± 0.12	0.33 ± 0.12

4 Timing Analysis

Data analysis was based on reaction time latencies evoked by the different brake lights. Calculations were based on three events; the time from brake light activation to accelerator release (*BrakeAcc*), the time from accelerator release to brake pedal depression (*AccPdl*), and the combined brake light activation to brake pedal depression (*BrakePdl*) duration.

BrakeAcc indicates the response time after the brake light appears and the subject releases their foot from the accelerator. This time can be considered to relate mainly to the cognitive element that starts as soon as the subject recognises the brake light, plus the time required to lift their foot from the accelerator. This is followed by the more automated reflex action where the subject moves their right foot from the accelerator to depress the brake pedal. That time is denoted as *AccPdl*. It is evident that the total reaction time from brake light flashing to brake pedal depression is $BrakePdl = BrakeAcc + AccPdl$.

As mentioned previously, each type of brake light was tested for a total of 45 onsets for each subject, providing 180 timing events, and thus 1800 timing events per volunteer.

The outputs of all analysis measures were subjected to Kruskal-Wallis tests (with $\alpha = 0.05$ as significance threshold) to gauge statistical significance, since the normality of data distribution was not assumed. Post-hoc Mann Whitney U testing with Bonferroni corrections were then applied where significant differences in the Kruskal-Wallis test was indicated, and thus determine any significant pair-wise differences. The overall hypothesis is that more efficient brake lights will induce shorter response times (i.e. lower latencies).

4.1 Results (Timing Analysis)

Tables 3 and 4 present the mean \pm standard deviation for *BrakeAcc* and *AccPdl* measurements, respectively. As can be observed from Table 3, experienced subjects responded quicker (i.e. released the accelerator pedal faster upon seeing the brake light activation) than the inexperienced subjects. Statistically, this was different for every brake light (all pairwise cases $p < 1e-3$) except the Fiat bulb unit ($U = -0.79, p = 2.13e-1$). This is in line with an expectation that experienced subjects might be more subconsciously assertive to the brake signal than inexperienced subjects.

Table 4: Mean latency and standard deviation (*BrakeAcc*, *AccPdl*, in seconds) from all brake lights for experienced drivers 1–11 (top) and inexperienced drivers 12–22 (bottom).

Subject	<i>BrakeAcc</i>	<i>AccPdl</i>
1	0.52 ± 0.10	0.46 ± 0.05
2	0.49 ± 0.11	0.25 ± 0.04
3	0.46 ± 0.13	0.31 ± 0.07
4	0.49 ± 0.10	0.47 ± 0.06
5	0.42 ± 0.08	0.22 ± 0.05
6	0.55 ± 0.13	0.34 ± 0.07
7	0.47 ± 0.12	0.49 ± 0.07
8	0.47 ± 0.14	0.32 ± 0.09
9	0.51 ± 0.15	0.22 ± 0.05
10	0.45 ± 0.07	0.20 ± 0.03
11	0.47 ± 0.14	0.34 ± 0.06
Average exp.	0.48 ± 0.03	0.33 ± 0.11
12	0.48 ± 0.10	0.29 ± 0.06
13	0.42 ± 0.09	0.24 ± 0.06
14	0.45 ± 0.12	0.44 ± 0.06
15	0.53 ± 0.11	0.24 ± 0.04
16	0.55 ± 0.17	0.32 ± 0.05
17	0.46 ± 0.11	0.32 ± 0.06
18	0.57 ± 0.11	0.37 ± 0.09
19	0.58 ± 0.21	0.55 ± 0.17
20	0.60 ± 0.18	0.22 ± 0.11
21	0.48 ± 0.16	0.35 ± 0.07
22	0.54 ± 0.19	0.30 ± 0.14
Average inexp.	0.52 ± 0.06	0.33 ± 0.10
Overall average	0.50 ± 0.05	0.33 ± 0.10

From Table 4, it can be seen that different brake lights also evoked different delayed responses from accelerator release to brake pedal depression (*AccPdl*). The abilities of experienced vs inexperienced subjects were mixed in this regard, showing that some brake lights have an influence on the speed of the subjects’ responses while some do not. Experienced subjects were quicker statistically in moving their foot from the accelerator to the brake pedal for the Ford bulb, Fiat LED and Volkswagen LED, but were slower for the Fiat bulb and Ford LED (all pairwise cases $p < 3e-1$).

Figures 12 and 13 show boxplots of latencies for *BrakeAcc* and *AccPdl*, respectively. It is evident from the figures that the median values of *BrakeAcc* were smaller for experienced subjects compared to inexperienced ones, which was true for every brake light (for *AccPdl*, it was mixed though). Figures 14 and 15 show the quantile-quantile (Q-Q) plot for *BrakeAcc* and *AccPdl* latencies for experienced vs inexperienced subjects. It can be seen that the inexperienced subjects had much longer *BrakeAcc* distributions (the distributions are similar early on, but diverge later). This showed that their overall medians were longer than for experienced subjects, but more importantly at the slow end of the reaction time distribution, inexperienced subjects were especially slow. This *slowness* in response is very important as it could be a causal factor in accidents; where drivers are slow to respond and thus crash into the car in front. However, this difference was not clearly evident for *AccPdl* latency, despite divergence later on showing the slowness of response for inexperienced subjects.

Comparing all the subjects (as shown in Figures 16 and 17), a statistical difference was also noted for both response latencies showing that subjects’ responses were dissimilar: *BrakeAcc*: ($H(9) = 2352.05, p = 0$), *AccPdl*: ($H(9) = 46.91, p = 4.08e-7$). The first 11 shown in the figures were experienced subjects with the rest being inexperienced.

Table 5: LED brake lights with the fastest and slowest response times for all subjects

Subject	<i>BrakeAcc</i> latency		<i>AccPdl</i> latency		<i>BrakePdl</i> latency	
	Fastest LED	Slowest LED	Fastest LED	Slowest LED	Fastest LED	Slowest LED
1	Ford	Volkswagen	Alfa Romeo	Volkswagen	Ford	Volkswagen
2	Fiat	Ford	Alfa Romeo	Ford	Fiat	Ford
3	Ford	Mercedes	Volkswagen	Honda	Volkswagen	Honda
4	Mercedes	Honda	Ford	Fiat	Ford	Nissan
5	Honda	Volkswagen	Audi	Nissan	Honda	Nissan
6	Nissan	Alfa Romeo	Alfa Romeo	Alfa Romeo	Honda	Alfa Romeo
7	Ford	Volkswagen	Ford	Honda	Ford	Volkswagen
8	Honda	Fiat	Mercedes	Honda	Mercedes	Ford
9	Ford	Fiat	Audi	Mercedes	Audi	Fiat
10	Alfa Romeo	Volkswagen	Volkswagen	Ford	Audi	Ford
11	Honda	Ford	Mercedes	Ford	Mercedes	Ford
12	Fiat	Mercedes	Alfa Romeo	Audi	Fiat	Audi
13	Alfa Romeo	Mercedes	Audi	Mercedes	Audi	Mercedes
14	Ford	Mercedes	Nissan	Honda	Ford	Fiat
15	Fiat	Mercedes	Fiat	Alfa Romeo	Fiat	Mercedes
16	Fiat	Honda	Honda	Fiat	Audi	Volkswagen
17	Audi	Mercedes	Audi	Volkswagen	Audi	Mercedes
18	Ford	Mercedes	Ford	Honda	Ford	Nissan
19	Honda	Alfa Romeo	Audi	Alfa Romeo	Audi	Alfa Romeo
20	Volkswagen	Alfa Romeo	Alfa Romeo	Volkswagen	Ford	Mercedes
21	Honda	Volkswagen	Ford	Mercedes	Ford	Volkswagen
22	Alfa Romeo	Volkswagen	Ford	Volkswagen	Ford	Volkswagen

Brake light reaction times for the 11 experienced subjects based on *BrakeAcc* and *AccPdl* are shown in Figure 18. As can be seen from the plot (the blue portion of the bars), both bulb versions of the brake assemblies from Ford and Fiat have the highest *BrakeAcc* response times (which was statistically significant from the eight LED lights, ($H(8), p = 0$) denoting that they were the slowest lights to draw a response. Between the two bulb units, there was no significant difference statistically ($U = -1.38, p = 0.16$). Among the LED brake lights, the slowest (i.e. the highest latency) was from Volkswagen which was statistically significant from every other LED light (all pairwise cases $p < 1e-9$), while the next slowest was Mercedes – however this was significant only compared to the Ford ($U = -3.84, p = 6.11e-5$) and Honda ($U = -3.81, p = 7.05e-5$) units.

The lowest *BrakeAcc* latency (i.e. the fastest light) were the Ford, Honda and Nissan units, although only Volkswagen and Mercedes indicated statistically significant differences in terms of the slower latencies as mentioned. This could possibly be due to their distinct characteristics: the Ford LED having the largest lit area, the Honda LED being the brightest, and the Nissan unit having the longest vertical lit dimension. Our previous studies based on brain response to LED light shapes revealed significant influence on cognitive responses for various shapes, orientations and brightness [30, 31, 37].

Considering the reaction times for the 11 experienced subjects based on *AccPdl* responses (the red portion of the bar), the general thought is that there should be no difference in terms of *AccPdl*. It should be relatively constant for each subject. However, the results indicated otherwise. The Ford bulb timings were significantly slower than for the Audi ($U = -2.86, p = 2.10e-3$), Alfa Romeo ($U = -3.72, p = 1.01e-4$) and Volkswagen ($U = -3.63, p = 1.41e-4$) LED units. Meanwhile the Fiat bulb timings were slower than the Audi ($U = -2.84, p = 2.20e-3$) and Alfa Romeo LED lights ($U = -3.74, p = 9.21e-5$). This indicated that the bulb had an additional negative effect which acted to reduce the reflex response component, in addition to the cognitive component. While we are analysing this effect further, we conjecture that the shape and/or

illumination level influences not only how quickly a subject can detect the brake signal, but how tentative or decisive the consequent response is.

Considering the total reaction time, *BrakePdl* (as shown in Figure 18, the full bars, both blue and red sections), in line with the other results, reports both the bulbs being statistically slower than any of the LED lights ($H(8), p = 0$). However, within the LED lights, there was no statistically significant difference between units ($H(7) = 4.99, p = 0.66$). However, from the plot we can see that Volkswagen LED tended to be the slowest, followed by the Mercedes unit.

The *BrakeAcc* responses from the inexperienced subjects is shown in Figure 19 (as the blue portion of the bars). The slowest responses were from both the bulbs ($H(8), p = 0$); between the bulb assemblies, the Ford was slower than the Fiat, ($U = 4.49, p = 3.62e-6$). Among the LED units, the slowest was from Volkswagen (statistically significant against all other LED units, ($H(7) = 72.83, p = 3.96e-13$)). This was followed by the Mercedes, which was statistically slower than the Audi ($U = 4.94, p = 3.97e-7$), Ford LED ($U = 6.38, p = 9.14e-11$) and Honda LED ($U = 4.78, p = 8.61e-7$). The fastest light was the Ford LED (which was statistically different from all but the Audi ($U = 1.19, p = 1.17e-1$) and the Honda unit ($U = 1.36, p = 8.66e-2$)).

In terms of *AccPdl* (shown in Figure 19 as the red portion of the bars), the expectation is again that there should not be any difference between the lights since the reflex response is what is being analysed. However both the Ford bulb and Volkswagen LED are statistically slower than the Alfa Romeo and Nissan LED units (all pairwise cases $p < 1e-5$)).

As expected from analysis of *BrakeAcc* and *AccPdl*, both the bulbs were slower than any of the LED lights when considering the total reaction times (the full bars in Figure 19) ($H(8), p = 0$). Among the LED units, there were more differences exhibited than there were for the experienced subjects. For example, the Volkswagen was statistically slower than the Audi, Nissan, Alfa Romeo, Ford, and Honda units (all pairwise $p < 1e-4$). Meanwhile the Ford LED unit was quicker statistically than those from Mercedes and Fiat (all pairwise $p < 1e-4$)).

Figure 20 compares the *BrakeAcc*, *AccPdl* and *BrakePdl* results (blue, red, full bars, respectively) for each brake light for all 22 subjects combined. Combining the *BrakePdl* analyses from both experienced and inexperienced subjects, both the bulbs are slower statistically than any of the LED lights ($H(8), p = 0$). The fastest LED was from Ford – statistically significant against all LED lights except the Audi and Honda (all pairwise $p < 1e-3$). The slowest was the Volkswagen unit (statistically significant from all other LED lights ($H(7) = 124.23, p = 1.00e-23$)), followed by the Mercedes LED (though it is statistically significant from the Audi, Ford, Honda and Nissan LED lights only (all pairwise $p < 1e-4$)).

Even though this study was focused on the cognitive response invoked by the various brake lights, interestingly the brake lights also influenced the reflex time taken for the foot to release from the accelerator and depress the brake pedal. Combining *AccPdl* from both experienced and inexperienced subjects, the Ford bulb was statistically slower than the Alfa Romeo, Mercedes, Audi and Nissan LED lights (all pairwise $p < 1e-4$) while

the Fiat bulb was slower than the Audi and Alfa Romeo LED lights (all pairwise $p < 1e-3$). Among the LED lights, there were some significant differences ($H(7) = 16.5, p = 2.09e-1$) with the Alfa Romeo being faster than the Honda ($U = 2.86, p = 2e-3$) and the Volkswagen units ($U = -3.26, p = 5.64e-4$).

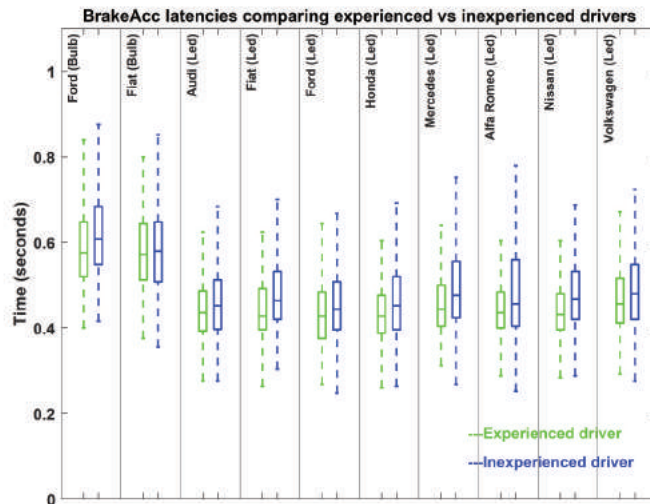

Figure 12: *BrakeAcc* latencies comparing experienced vs inexperienced subjects.

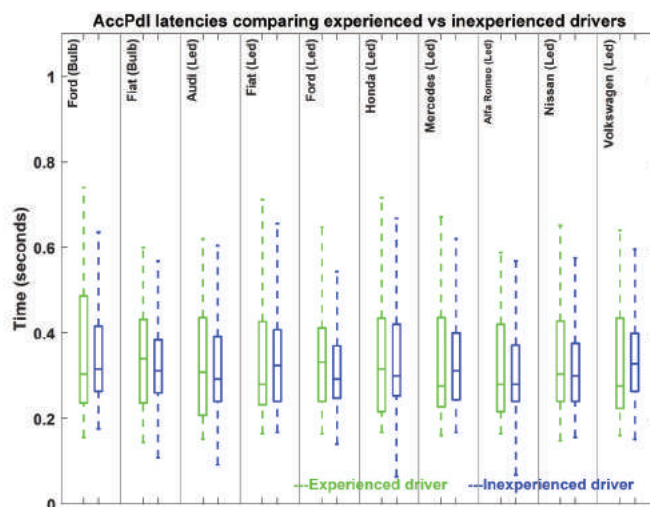

Figure 13: *AccPdl* latencies comparing experienced vs inexperienced subjects.

The full bars of Figure 20 present the total reaction timings for all subjects. *BrakePdl* for both bulbs was statistically slower than for any of the LED lights (all pairwise cases $p < 1e-53$). Among the LED units, the Volkswagen was slower than the Audi, Ford, Honda, Alfa Romeo and Nissan units (all pairwise cases $p < 5e-3$) while the Mercedes unit was slower than the Ford ($U = -4.53, p < 2.89e-6$). We speculate the results from the Volkswagen unit was at least partially a result of pattern in which it illuminates (see Section 4.2).

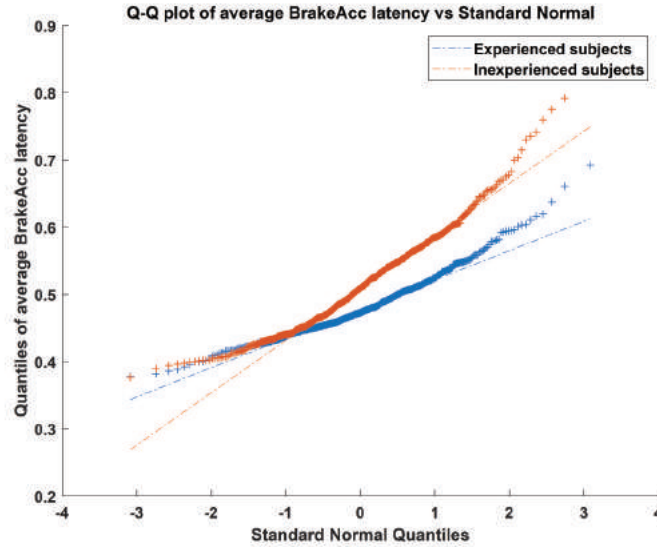

Figure 14: Accelerator release latency (*BrakeAcc*) subject wise for ALL brake lights.

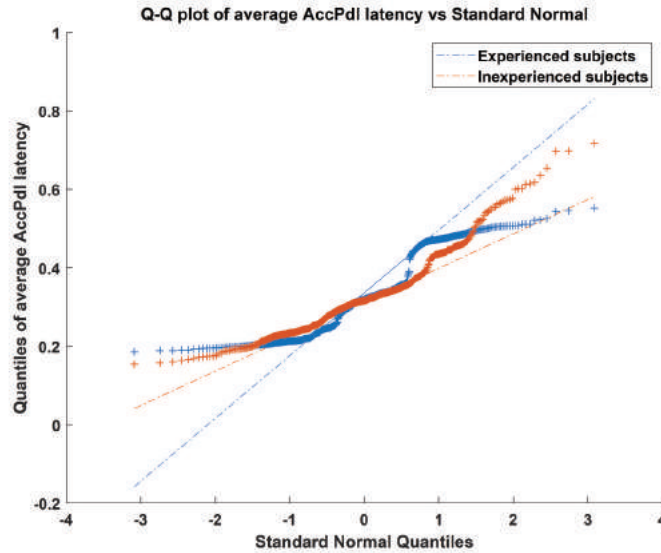

Figure 15: Accelerator release to brake pedal latency (*AccPdl*) subject wise for ALL brake lights.

The results also showed that *BrakeAcc* is statistically longer than *AccPdl* for every brake light (all pairwise $p = 0$, indicating that it took longer for subjects ($0.50 \pm 0.05s$) to act on the detected brake light illumination than to depress the brake pedal ($0.33 \pm 0.10s$). This indicated that more time was required by subjects to perceive the activation of brake lights, but they are generally quicker to act once brake light activation is recognised. Among the LED lights, the best and worst responses were mixed for each subject as shown in Table 5. Nevertheless, the results do indicate that the time between seeing the brake light illuminating, and releasing the accelerator, is the critical interval where the different types of lights can influence the speed of braking reaction.

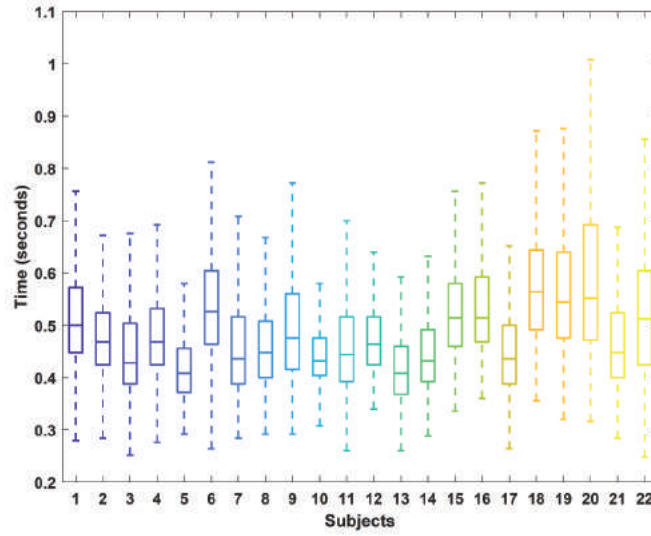

Figure 16: Accelerator release latency (*BrakeAcc*) subject wise for ALL brake lights (the first 11 subjects were experienced drivers).

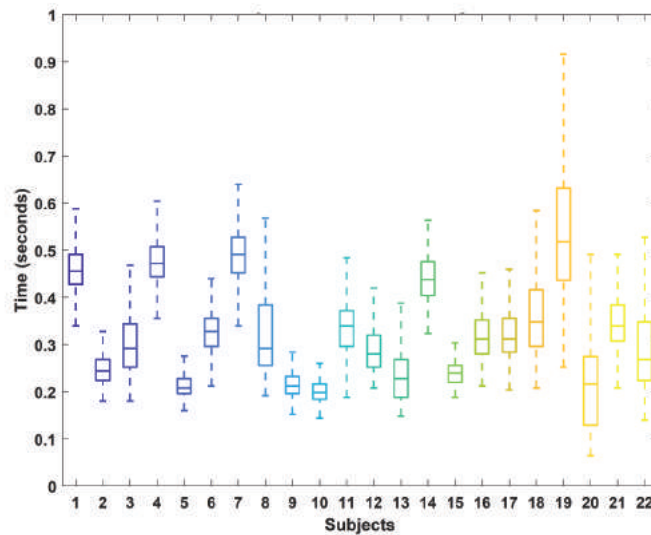

Figure 17: Accelerator release to brake pedal latency (*AccPdl*) subject wise for ALL brake lights (the first 11 subjects were experienced drivers).

Figure 21 shows the *BrakeAcc* latency versus the age of all the subjects (in years). There was no significant correlation ($r^2 = 0.0385, p = 3.82e-1$), indicating clearly that age, within the range tested, had no influence on the speed of recognition of the brake light activation.

Figure 22 plots *AccPdl* latency versus the experience of all the subjects (in months). There was no significant correlation statistically ($r^2 = 0.15, p = 7.52e-2$), although the small p value and $r^2 = 0.15$ do indicate that there is some correlation between driving experience and speed of recognition of the brake light activation, i.e. more experienced subjects are quicker to respond.

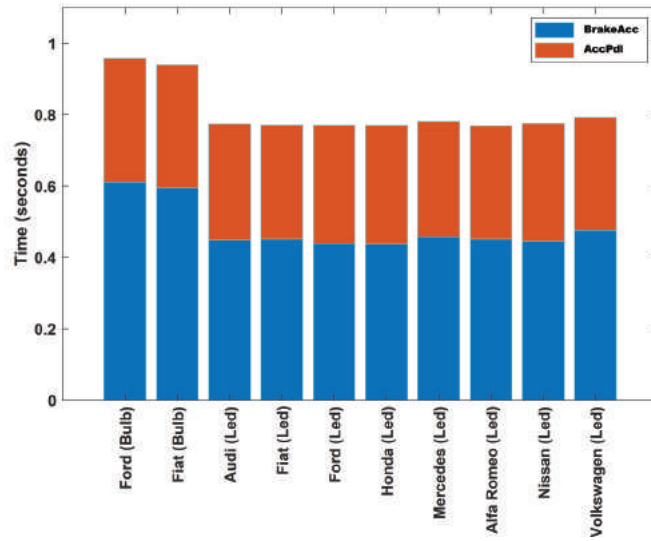

Figure 18: Mean latencies (*BrakeAcc*, *AccPdl*) for ALL brake lights (for the experienced drivers).

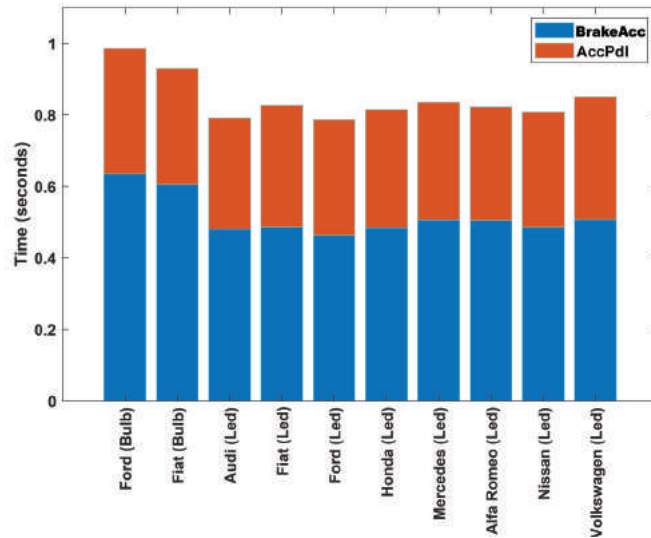

Figure 19: Mean latencies (*BrakeAcc*, *AccPdl*) for ALL brake lights (for the inexperienced drivers).

There was no significant correlation statistically when comparing *AccPdl* latencies with age ($r^2 = 0.0164, p = 5.70e-1$) showing that age does not have an influence on the reflex action. There was no significant correlation statistically when comparing *AccPdl* latencies with experience ($r^2 = 0.0648, p = 2.53e-1$) showing that age and experience do not have an influence on the reflex action, which could likely be more influenced by the subject's physical ability and innate speed of reflex movements.

The probability distributions for experienced and inexperienced subjects using averaged *BrakeAcc* latencies are shown in Figure 23. The dotted red lines indicate the normal distribution and it can be seen that there is greater variation for inexperienced subjects

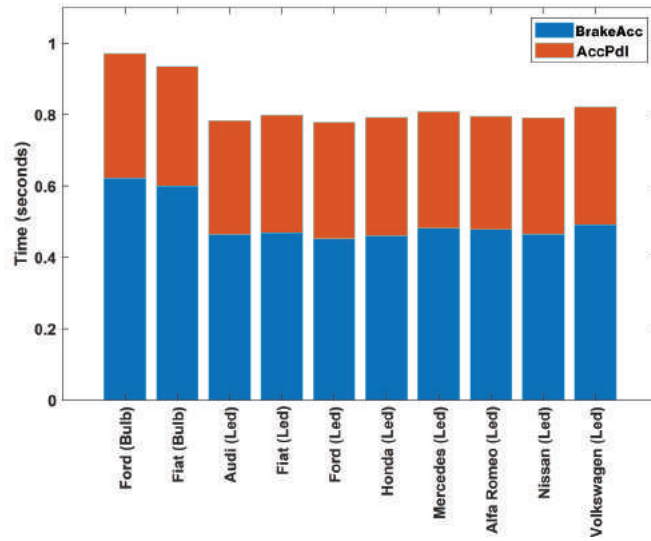

Figure 20: Mean latencies (*BrakeAcc*, *AccPdl*) for ALL brake lights (for ALL subjects).

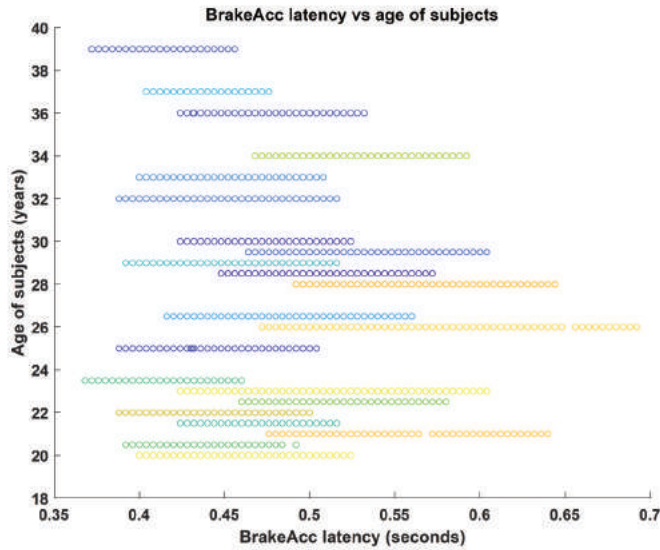

Figure 21: *BrakeAcc* latency with respect to subject age.

(shown with a less steep red line). For example at 0.95 probability (5%), we can see that experienced subjects took an average 0.56s to release the brake pedal while inexperienced subjects took an average of 0.65s.

Considering the three brake lights (slowest light overall, slowest LED and fastest light overall), Figure 24 shows the probability distribution for all the subjects in terms of total reaction latencies (*BrakePdl*). At 0.95 probability (5%), the latencies were 1.03, 1.14 and 1.36s for the Ford Bulb, Volkswagen LED and Ford LED unit. Considering the fastest speed of 1.03s, the probability would stand at 0.89 and 0.68 for the Volkswagen LED and Ford Bulb respectively. Thus, 6% more subjects were slower when comparing the Volkswagen and Ford LED lights and 27% more subjects were slower when comparing the Ford bulb and Ford LED.

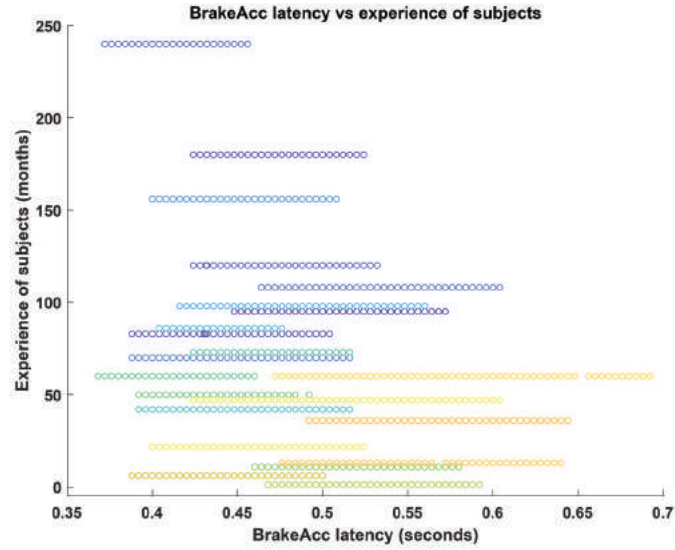

Figure 22: *BrakeAcc* latency vs experience level of subjects.

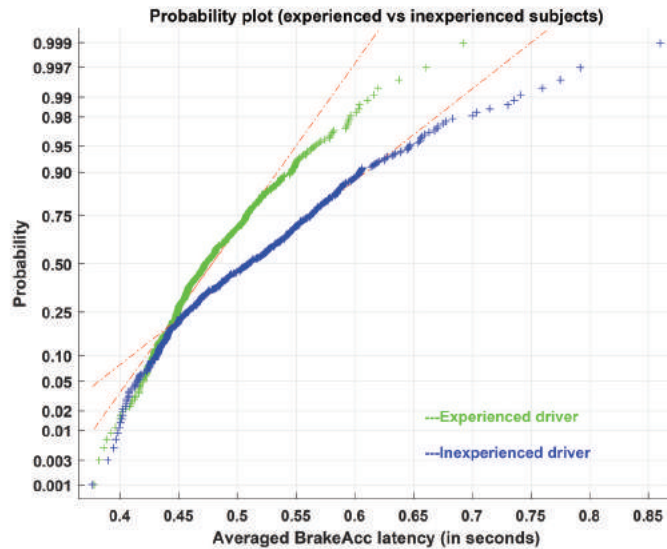

Figure 23: Probability plot (experienced vs inexperienced subjects).

4.2 Conclusion (Timing Analysis)

Reaction time data from 22 subjects for ten brake light assemblies were analysed statistically. Results indicate that versions of the brake lights containing incandescent bulbs (e.g. Ford and Fiat) induced statistically slower reaction times than all of the tested LED units. It is known that incandescent bulbs take longer to illuminate (generally no discernible optical output for around 50 ms post switch on), but the cognitive reaction time delay difference was found to be about 170 ms between the incandescent bulb and LED equivalents (e.g. between the Ford LED and bulb assemblies). This clearly reveals that LED units have the potential to evoke brain responses quicker.

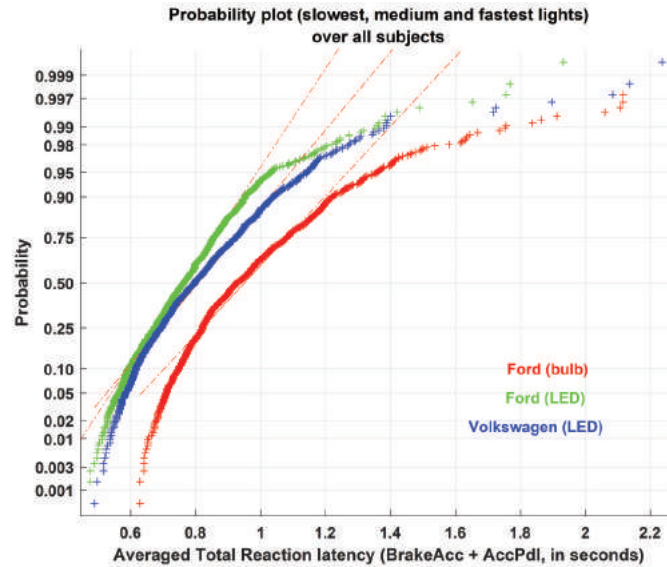

Figure 24: Probability plot (slowest, medium and fastest lights) over all subjects.

It was also shown that experienced subjects were quicker to realise the activation of a brake light, and hence release the accelerator quicker. A noteworthy finding here is that the brake light type also influenced the time between accelerator release and brake pedal depression. Furthermore, experienced subjects did not always act quicker than inexperienced subjects in this regard. These points are probably worthy of further analysis from the cognitive perspective, especially in terms of the relationship between shape and cognition.

The Ford brake light shell had a larger lit area than the other brake lights, which could have led to improved visibility. The Volkswagen brake light had a unique dispersed illumination pattern, with the major lit area being towards the exterior and less focused to the centre of the brake light unit. The Mercedes brake light also had an elliptical illumination pattern, with the centre of the light unit being unlit. Comparing the lights inducing the slowest response (the bulb units), both lacked illumination at the centre of the brake shells, which could contribute to the slower times.

In future, it is hoped that experiments could be run in real-life traffic conditions (i.e. live, on the road) to assess any deviation from the responses obtained in the laboratory environment.

4.3 EEG Analysis

Data analysis was based on brain responses evoked by the different brake lights simulation. The EEG data recorded from channel Pz was utilised for this purpose. The brain response component P3 (also known as P300) is evoked during decision making processes that occurs in the brain when the subjects decide to lift their foot from accelerator and depress the brake pedal. P3 component is maximal in mid-line parietal and hence the selection of Pz for the location.

The EEG data is filtered from channel Pz (for noise reduction) from 0.1 to 8 Hz using Infinite Impulse Response filter to remove the baseline noise and moreover as P3 is a low frequency component. Next, the EEG is segmented into 45 segments, each corresponding to one brake light activation (as there were 45 brake light activations per brake light for each subject). Each segment of 1.2 seconds is obtained for the period of 0.2 seconds before the brake light onset and 1 second afterwards, which is sufficient to capture the evoked brain responses. The segments are averaged to reduce EEG components that are not time-locked to the brake light cognitive processing. Figures 25 and 26 show examples of the averaged brake light from one subject from Ford bulb and Ford LED, respectively. In this figure, the evoked P3 component can be seen as marked, with the latency (time delay) indicated by the double arrow. It is also possible to see that Ford LED's P3 latency is lower compared to Ford bulb.

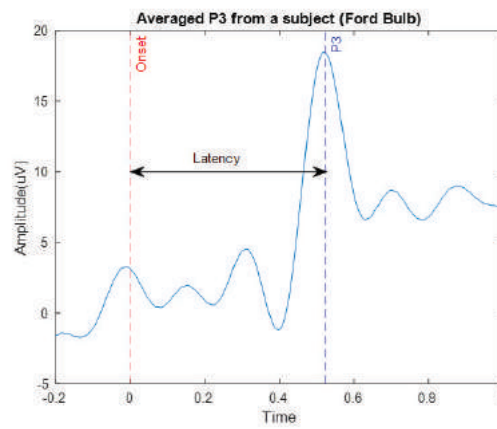

Figure 25: Averaged P3 plot from a subject for Ford Bulb.

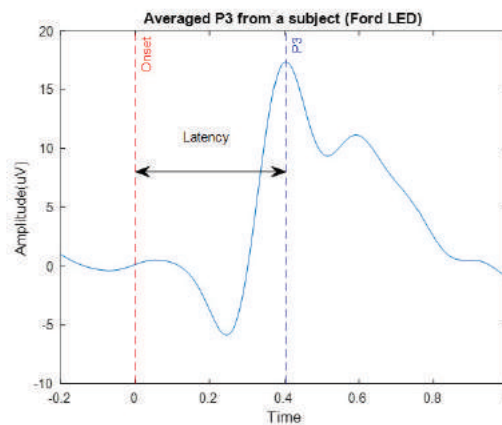

Figure 26: Averaged P3 plot from a subject for Ford LED.

4.4 Results (EEG Analysis)

Figure 27 shows the latency of P3 components from EEG for all the brake lights. There was statistical difference between the P3 latencies from the different brake lights (Kruskal-Wallis, $H(9)=84.09, 2.48 \cdot 10^{-14}$). The bulbs were statistically slower than LED (using

averages of the two bulbs and averages of the eight LED lights, Mann-Whitney U, $Z=5.32$, $p=4.94e-8$).

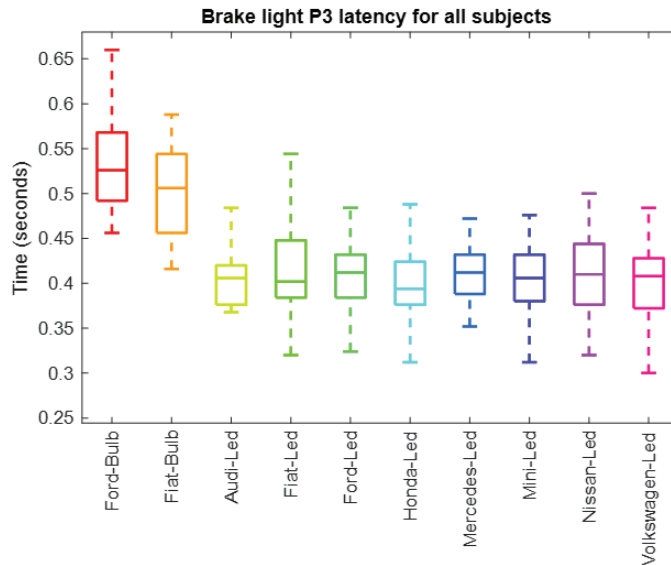

Figure 27: Latency of P3 components from EEG for all brake lights.

Within the bulbs, Fiat bulb had lower P3 latency than Ford bulb (Mann-Whitney U, $Z=1.72$, $p=0.04$). Ford bulb had the highest P3 latency of all the lights, i.e. Ford bulb was the slowest of all the lights.

Within the LED lights, there were differences but not statistically significant ($H(7)=1.81$, $9.7e-1$). We speculate this could be due to the noise in the P3 response, where the cognitive component related to the perception and recognition of the brake activation might be confounded with movement-related artifact as subjects were lifting the leg from the accelerator and depressing the brake pedal. Nevertheless, the fact that there is a strong statistical difference between the bulb and LED brake lights for the P3 latency does show that LED-based brake lights have a clear advantage in their effectiveness to draw a quicker response from subjects.

Table 6: Mean and standard deviation of P3 latencies for the different brake lights

Subjects	Bulb		LED							
	Ford	Fiat	Audi	Fiat	Ford	Honda	Mercedes	Alfa Romeo	Nissan	Volkswagen
Experienced	0.53 ± 0.06	0.51 ± 0.05	0.42 ± 0.05	0.41 ± 0.06	0.41 ± 0.05	0.41 ± 0.02	0.41 ± 0.03	0.42 ± 0.03	0.42 ± 0.06	0.41 ± 0.03
Inexperienced	0.54 ± 0.05	0.50 ± 0.05	0.40 ± 0.07	0.41 ± 0.04	0.40 ± 0.06	0.39 ± 0.05	0.41 ± 0.04	0.41 ± 0.08	0.41 ± 0.07	0.40 ± 0.08
All subjects	0.54 ± 0.05	0.50 ± 0.06	0.41 ± 0.05	0.41 ± 0.05	0.41 ± 0.05	0.40 ± 0.04	0.41 ± 0.03	0.41 ± 0.06	0.42 ± 0.07	0.41 ± 0.06

Although there was no difference statistically between the experienced and inexperienced subjects (Mann-Whitney U, $Z=1.21$, $p=8.87e-1$), Figure 28 shows the probability plot which indicates that inexperienced subjects are much slower to respond (indicated by the smaller gradient of the normal red line) as compared to the experienced subjects. This is as expected.

Figure 29 shows the P3 latency versus the driving experience of the subjects (in months). There is no significant correlation between the P3 latency and experience,

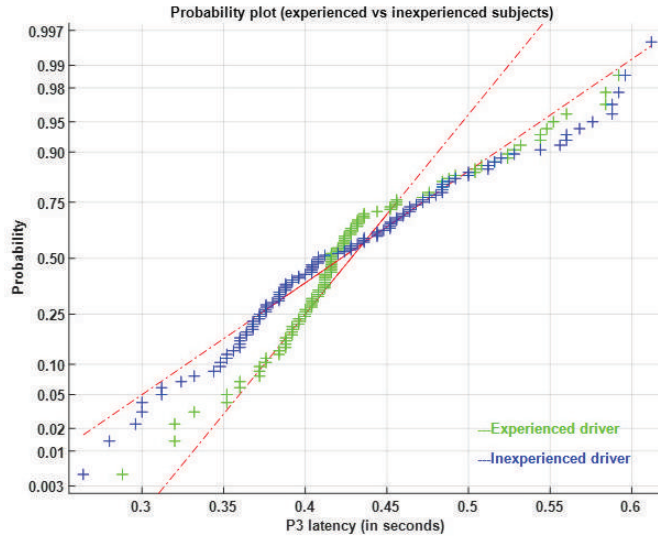

Figure 28: Probability plot of P3 latencies (experienced vs inexperienced) for all brake lights.

which could be due to the artifact issues mentioned earlier (adjusted $r^2 = -0.04$, $p = 0.665$). Similarly, Figure 30 shows the P3 latency versus the age of the subjects in years where there is no significant correlation as well (adjusted $r^2 = -0.05$, $p = 0.85$).

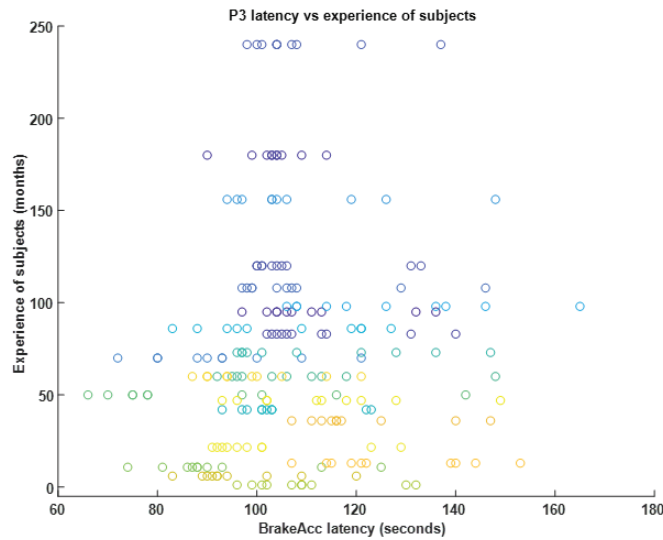

Figure 29: P3 latencies versus driving experience of subjects for all brake lights.

Figure 31 shows the P3 latencies subject wise where the first 11 are experienced subjects. There are significant differences between subjects ($H(21)=75.29$, $4.87e-8$), between experienced subjects ($H(21)=27.4$, $2.22e-3$) and inexperienced subjects ($H(21)=43.59$, $3.91e-6$). Comparing inexperienced subjects, experienced subjects have less difference amongst them as indicated by the higher p value in the Kruskal-Wallis statistical test. This is as expected as inexperienced subjects will tend to have larger variance amongst their abilities to respond to the brake lights.

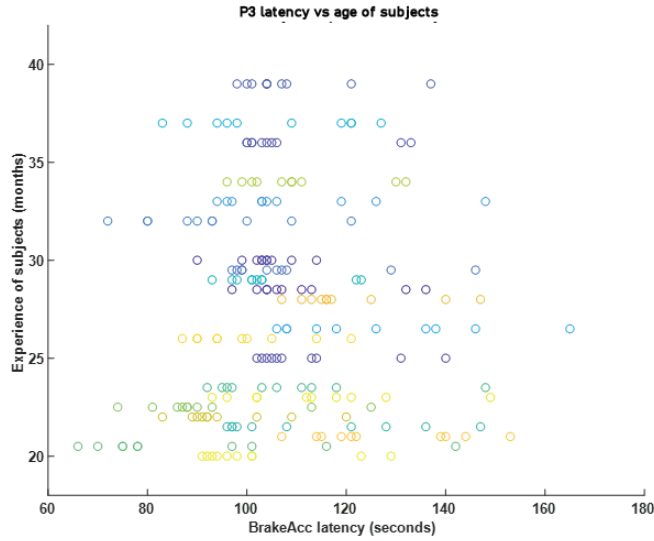

Figure 30: P3 latencies versus age of subjects for all brake lights.

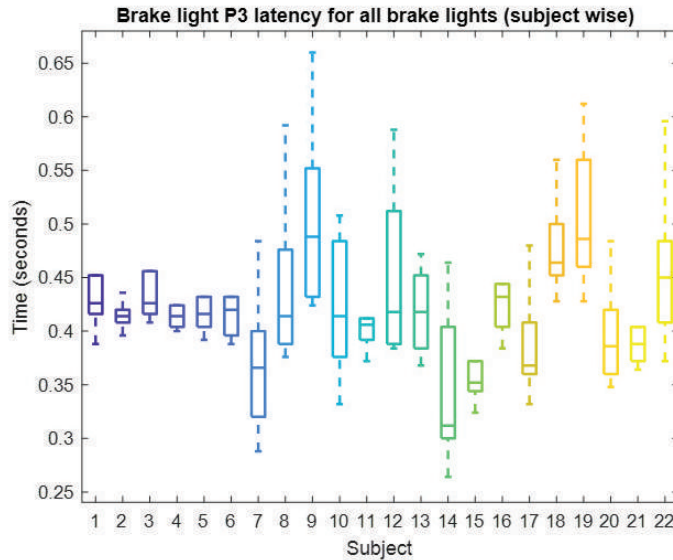

Figure 31: P3 latencies for all brake lights subject wise.

Table 6 shows the mean and standard deviation of P3 latencies from all the brake lights. The slowest light is Ford bulb, which was also indicated by the timing analysis. The fastest according to the P3 latency is the Honda LED, although this was not statistically significant from other LED lights.

4.5 Conclusion (EEG Analysis)

P3 components have been analysed from channel Pz from 22 subjects from ten different brake lights and analysed for statistical differences in terms of the latency of the cognitive component from the brake light onset. It was found that both the bulb based lights were slower than all the LED lights but there was no statistically significant difference among

the LED brake lights. Ford bulb indicated to be the slowest from the P3 analysis. The lack of significant differences in the P3 latency for LED based lights could be attributed to the significant amounts of noise in the EEG caused by movement and other artifacts.

4.6 Final conclusion from WP2

Based on the data collected from 22 participants with various brake lights, the timing analysis showed bulb-based brake lights are slower than LED based brake lights. Within LED, there were differences with Ford LED being the quickest to draw responses. Comparing the age of participants, it did not show any difference, but driving experience mattered. Analysing the EEG, bulb-based lights had the slower response. Within LED lights though, EEG analysis does not show much difference. This might be due to noise present in the signal and implementing advanced noise reduction methods may reveal differences. Analysis on the age, experience, gender and their influences on the brake lights could also be done in the future work.

5 Future Directions

For the immediate future work (hopefully by other parties with our involvement), development of noise reduction algorithms would be required to analyse the actual cognitive responses from the braking events using electroencephalogram (EEG) signals in real-life traffic conditions (i.e. live, on the road) as this would allow to understand the brain processes involved in the recognition of the lights and the corresponding braking actions. In the next subsections, we describe possible plans for WP3 and WP4.

5.1 WP3 Suggestions

WP3 will focus on obtaining responses from participants outside the lab on the real road using specifically chosen brake lights that have shown significant differences in WP2. The aim of this work plan would be to identify if the results obtained in the lab environment are replicated in the real-world and to study on any deviations to incorporate in work plan 4.

The WP3 experimental paradigm involves: hardware design for inter-car communication to send and receive braking event triggers; EEG data collection procedures; fixtures for temporary brake light mounting; travel route specification and safety procedures. The WP2 results using reaction time (RT) from ten sets of brake lights with 22 participants identified the Ford LED as the most responsive brake light with minimum reaction time for both cognitive and reflex elements. The other brake lights with slightly higher RT than Ford were Audi LED and Honda LED. The highest RT (i.e. slowest light) observed in the LED category was from Volkswagen.

For this experiment, we recommend three lights with the lowest RTs and one with the highest RT (namely Ford LED, Audi LED, Honda LED and Volkswagen LED) for

the real-world study. The chosen brake lights are all LED types, since the incandescent lights have shown statistically higher RTs than any LED types for every subject and in our WP2 report, and are hence not recommended for use as brake lights if LED bulbs are available. However further exploration is needed into the difference between the narrow spread of LED light results. As such, we suggest not to use any incandescent bulb based lights in WP3.

The recommended experimental paradigm for this study would require two cars with customised hardware installed for data collection as shown in Figure 32. Both cars would participate in the data collection simultaneously. The leading car would be fitted with the brake lights for evaluation, while the following car would have the participant with EEG hardware connected. The hardware development, firmware development and data collection procedures are discussed in the sections below.

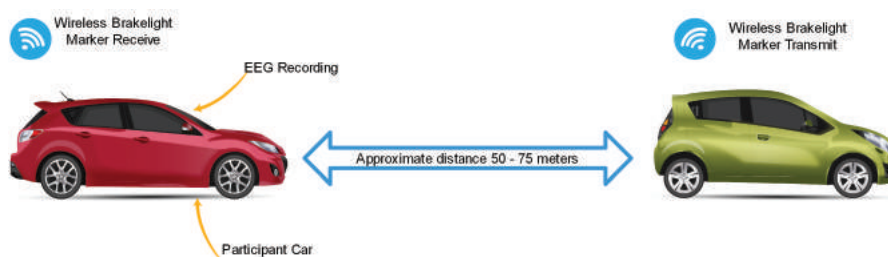

Figure 32: Leading and trailing cars in the experiment

Since there is not brake light simulation in this real world study, the brake lights that needs to be tested should be mounted on the leading car. We recommend the leading car would be fitted with a cycle carrier with customised mounting brackets for the selected brake light pairs and would be wired directly to the existing wiring loom of the factory fitted brake light. The factory fitted brake light would be temporarily disconnected for the duration of the experiment. When the brake pedal is pressed, the brake light under test would be illuminated rather than the factory fitted brake light. The test brake light connectors would be customised to be modular to be easily swapped. To create an event trigger for the brake light activation and to reduce the noise, we suggest usage of an opto-isolator connected to the wiring loom that would send an active state alert to the microcontroller. The block diagram for the event transmitter is shown in Figure 33.

Similarly, the following car, which would be driven by the participant, would contain receiver hardware to receive the event trigger from the leading car and time stamps the event along with the EEG being recorded from the participant. The proposed hardware would record the brake light events from the participant’s car, similarly using an opto-isolator connected to the existing brake light wiring loom and tags it along with the EEG data as shown in Figure 34. The various time stamps could be used later in the analysis to investigate the influences of selected brake lights on reaction time.

5.1.1 Hardware prototype and firmware development

Unlike the highly controlled laboratory environment, where the brake light distance was always fixed, the real-world experiment will have more variability, including the distance

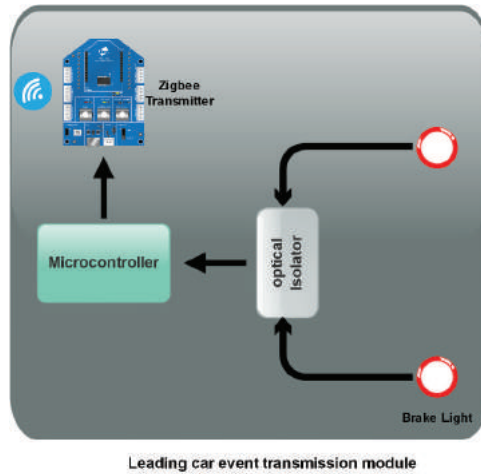

Figure 33: Brake light event transmission block diagram

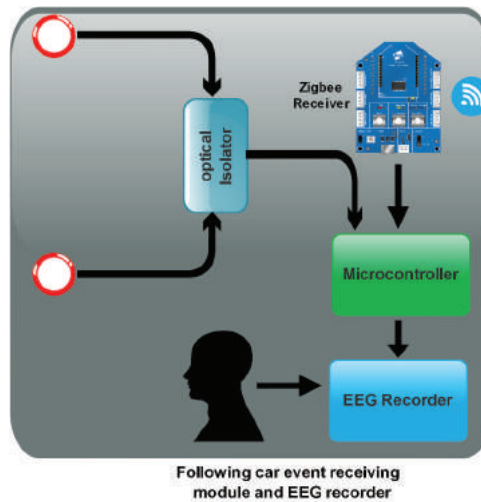

Figure 34: Brake light event reception block diagram

between cars, partial obstructions when the leading car takes a turn and so on. This leads to potential hardware issues in the real environment, as well as removing any possibility of wired links (as in the lab). To mitigate these issues and ensure reliable communications, robust wireless transmission and reception hardware is necessary. The wireless communication links we are developing use industry-standard programmable Xbee RF modules which include microcontrollers. A pair of Xbee devices, with an outdoor communication range of at least 1000 meters, would be used to transmit and receive event markers. The hardware prototype will be based on an ARM M4 microcontroller as shown in Figure 35. For improved time accuracy, both the microcontroller units will be equipped with real-time clock (RTC) modules and be synchronised for millisecond accuracy. The event triggers transmitted and received would have time stamps for transmission and reception.

Custom firmware to be developed for both transmitter and receiver modules separately. The transmitter module would send a single event every time the leading car brakes, whereas the receiver module should have two functions; first to receive the above

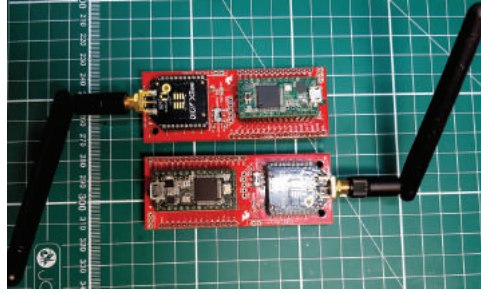

Figure 35: Event trigger transmitter and receiver

data and time stamp it alongside the recorded EEG stream, and secondly capture braking event from the participant car, and time stamp this for recording along with the other. The complete unit should be battery powered to minimise any interference inside the cars from automotive electrics.

5.1.2 EEG hardware and electrode setup

EEG recordings were conducted in a laboratory environment where body movement was minimal with little noise interference corrupting the data. For this real-world experiment, an active electrode EEG hardware recorder should be used to minimise the interference. This would also reduce any interference from the car electrics as well as enjoy the benefit of better scalp conductivity which can be monitored in real time throughout the experiment (i.e. even while on the move). The electrode layout is shown in Figure 36.

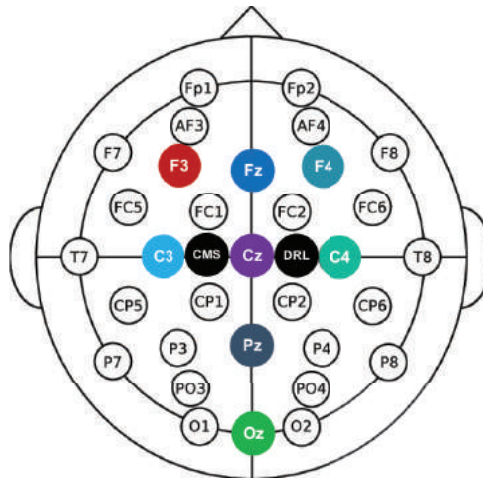

Figure 36: EEG electrode layout

5.1.3 Data acquisition

We recommend that the study should focus on exploring the differences between the laboratory and real environments in this phase. When setting up the experiment, EEG caps would be fitted on each participants head and gel would be applied to the electrodes. The contact quality would be characterised to ensure data reliability. Both the cars would

travel on a predefined route for approximately 10 - 12 minutes, which would generate 40 to 50 braking events. The participating driver would be instructed to drive normally, while following the leading car at a roughly specified distance, braking as and when required. The participant car's braking events, other than acting as tagged events to determine the timing with respect to the leading car, will not be considered for data analysis. After each trial, the brake light under test should be replaced with a new set of lights, and the same trial performed again.

5.1.4 Data analysis

In terms of EEG data, we expect to see a lot of noise interference due to subject movement (i.e. muscle artefacts and associated preparatory potentials in the brain). Although the active electrodes reduce contamination of EEG with noise, complete removal of noise components is still likely to be a challenge. Analysis should use validated pre-processing pipeline, which uses blind source separation techniques (e.g. independent component analyses) and statistical characterisation of bad channels (e.g. kurtosis and Hurst exponent), to reduce the noise and extract appropriate cognitive patterns related to braking events that could be analysed.

The data analysis should be able to explore any variations between data obtained in WP2 and WP3. These findings could be then incorporated into WP4 to ensure that the developed brake lights would show statistically validated improved response times.

5.2 WP4 Suggestions

Based on the results from WP3, the experimental paradigm for WP4 could be developed for developing efficient brake lights. We propose the use of Neo-Pixel LED Matrix panels that could be cascaded to build a 50cm X 50cm matrix which could be programmed to display the brake lights using different patterns similar to the brake lights from various car manufacturers. This platform would also have the benefit of not changing the brake lights to analyse a different shape or illumination intensity. Since this is based on LED lights, the delay would also be minimal. Cognitive responses for different light patterns could also be explored using the same hardware prototype.

6 Contributions

Contributions of the project could be summarised as follows.

1. **Literature review:** A complete updated literature review.
2. **Research findings:** Based on the data collected from 22 participants with various brake lights, the timing analysis showed bulb-based brake lights are slower than LED based brake lights. Within LED, there were differences with Ford LED being the quickest to draw responses. Comparing the age of participants, it did not show

any difference, but driving experience mattered. We have used the unique timing analysis to identify the cognitive response after seeing the brake light and lifting the foot from the accelerator which would assist in understanding the influence of cognitive action component of raising the accelerator pedal after seeing the brake light. This analysis showed that at the slow end of the reaction time, inexperienced participants are especially slow. Analysing the EEG, bulb-based lights had the slower response. Within LED lights though, EEG analysis does not show much difference. This might be due to noise present in the signal and implementing advanced noise reduction methods may reveal differences. Further analysis on the age and experience, and their influences on the brake lights are also included.

3. **Data (including manual):** The web page (<http://www.brake-light.uk>) developed have all the data collected (EEG plus timing data). The data have been anonymised so no subject related information is present (other than gender, age, experience). This will be a very useful data set given that there were 22 participants and 10 different brake lights.
4. **Experimental methodology:** We have developed significant amount of hardware for triggering the brake light randomly and to capture the events along with the EEG data for analysis. All the details (including circuit diagrams) is included in this final report.
5. **Unique timing analysis:** We have also looked at the timing from brake light event to accelerator lift, which is unique and assists in understanding the influence of cognitive action component of lifting the accelerator pedal after seeing the brake light. Majority of the existing studies look at the timing from brake light event to brake light depression, not including the intermediate accelerator lift action thereby coming up with possibly incorrect conclusions.
6. **Real-world methodology plan:** Based on our experience designing and implementing different experimental protocols, a plan for real-world methodology for efficient EEG data collection and associated hardware development is presented in this final report.
7. **Publications:** Open access papers which could be used as reference for future studies:
 - (a) R. Palaniappan, S. Mouli, E. Fringi, I. McLoughlin, H. Bowman, “Incandescent Bulb and LED Brake Lights: Novel Analysis of Reaction Times,” IEEE Access, vol. 9, pp: 29143 – 29152, 2021, Available: <https://ieeexplore.ieee.org/document/9351984>
 - (b) R. Palaniappan, S. Mouli, H. Bowman, I. McLoughlin, “Investigating the cognitive response of brake lights in initiating braking action using EEG,” IEEE Transactions on Intelligent Transportation Systems, Avail-

8. **Future work suggestion:** A section for future research directions is included in the final report (with design experimental protocols, hardware implementation, and EEG data collection guidelines).

7 Final Conclusion

After the completion on WP2, mechanical activation and EEG data from 22 participants over ten brake light sets was analysed statistically. Results indicate that versions of brake lights containing incandescent bulbs (namely Ford and Fiat) are slower than all the eight LED lights (and this result is statistically significant). It is known that bulbs taken longer to light up (for example, there is usually no discernible light output until up to about 50 ms, after power is applied) but the cognitive reaction time delay was about 170 ms when comparing a bulb and its LED equivalent (measured for the Ford LED and incandescent lights), which shows that LEDs have the ability to evoke brain responses quicker. The best performing LED light overall was the Ford LED while the worst overall was the Volkswagen LED followed by that from Mercedes.

Ford brake light shell had larger lit area as compared to other brake lights, which could have led to improved the visibility. The Volkswagen brake light had a unique light up pattern and the major lit area was towards the exterior and less focused at the centre of the brake light unit. Mercedes brake light also had an elliptical light up pattern, and the centre of the light unit were not lit. Comparing the least performing lights (i.e. the bulbs), both units lacked illumination at the centre of the brake light units, and that could be the reason for causing longer delays.

EEG analysis based on the P3 component shows statistical differences in latencies from different brake lights. The bulbs were statistically slower than LED. Within the bulbs, Fiat bulb had lower P3 latency than Ford bulb. Ford bulb had the highest P3 latency of all the lights, i.e. Ford bulb was the slowest of all the lights. Within LED based lights, there were differences but was not statistically significant. This could be due to the noise in the P3 response with movement related artifact while the participants were lifting the leg from the accelerator and depressing the brake pedal. Comparing the LED and bulb based brake lights, there is strong statistical difference between both for the P3 latency and LED based brake lights have a clear advantage in their effectiveness to draw quicker response from participants.

We could not fully complete the project but had to stop prior to commencing WP3. We had a number of issues:

1. **Staffing issues** - Major loss of staffing due to the restructuring exercise at University of Kent which meant that there were very little human resources left to carry on the project. Moreover, some the staff who left had specialised expertise in the area which could not be replaced.

2. **Pandemic situation** - WP3 involves the real world study that would require multiple people inside the car (participating driver, safety marshall and EEG data recorder handling person). Safe distancing would not be possible according to the government guidelines and that is one main issue with this WP3 phase going forward.
3. **Ethical approval** - Due to the current pandemic situation, ethical application was not approved for WP3 plan by the University of Kent Ethics committee.

Road Safety Trust had on numerous occasions agreed for revisions to the proposal, which we are grateful but the complications were too serious and the project could not continue. We hope that this report will encourage involvement of other parties to continue the project from where we have left off. We would be inclined to work together with any like minded parties in continuing with the outcomes.

Acknowledgement

We acknowledge the support of the Road Safety Trust (RST 90.4.18) in funding this study. The research was conducted with the aim of increasing road safety, and did not have the involvement of any manufacturer. We note that only one type of light assembly from a single vehicle within each manufacturers range was assessed, and results are therefore not to be interpreted as applying to any other vehicles or brake light assemblies, and certainly not as any endorsement or otherwise of a particular manufacturer. We also acknowledge that the sample sizes here are quite small, so it would be appropriate for replications of the work to confirm the findings.

References

- [1] World Health Organization, “Global status report on road safety 2018: Summary,” tech. rep., WHO/NMH/NVI/18.20, 2018.
- [2] National Highway Traffic Safety Administration, “Traffic safety facts 2017 Washington, DC: US department of transportation, national highway traffic safety administration,,” tech. rep., DOT HS 812 806, 2019.
- [3] D. Robineau, M. Dark, P. Baden, A. Bhagat, A. Dhani, and H. Mann, “Reported road casualties in Great Britain: 2017 complete report,” tech. rep., Department for Transport, 2018.
- [4] Murphy, A., “Reported road casualties in Great Britain: 2019,” tech. rep., Department for Transport, 2019.
- [5] J. D. Bullough, J. V. Derlofske, and M. Kleinkes, “Rear signal lighting: From research to standards, now and in the future,” in *SAE Paper 2007-01-1229*, Warrendale, PA: Society of Automotive Engineers, pp. 61–69, SAE International, 2007.
- [6] J. Gao and G. A. Davis, “Using naturalistic driving study data to investigate the impact of driver distraction on driver’s brake reaction time in freeway rear-end events in car-following situation,” *Journal of Safety Research*, vol. 63, pp. 195 – 204, 2017.
- [7] R. B. Isler and N. J. Starkey, “Evaluation of a sudden brake warning system: Effect on the response time of the following driver,” *Applied Ergonomics*, vol. 41, no. 4, pp. 569 – 576, 2010.
- [8] G. Li, W. Wang, S. E. Li, B. Cheng, and P. Green, “Effectiveness of flashing brake and hazard systems in avoiding rear-end crashes,” *Advances in Mechanical Engineering*, vol. 6, p. 792670, 2014.
- [9] Z. Li and P. Milgram, “An empirical investigation of a dynamic brake light concept for reduction of rear-end collisions through manipulation of optical looming,” *International Journal of Human-Computer Studies*, vol. 66, no. 3, pp. 158 – 172, 2008.
- [10] Q. Luo, X. Chen, J. Yuan, X. Zang, J. Yang, and J. Chen, “Study and simulation analysis of vehicle rear-end collision model considering driver types,” *Journal of Advanced Transportation*, vol. 2020, 2020.
- [11] N. Stanton, R. Lew, N. Boyle, R. J. Hope, B. P. Dyre, and E. A. Bustamante, “An implementation of a graded deceleration display in brake light warning systems,” *Proceedings of the Human Factors and Ergonomics Society Annual Meeting*, vol. 55, no. 1, pp. 1573–1577, 2011.
- [12] W. W. Wierwille, S. E. Lee, M. C. DeHart, and M. Perel, “Test road experiment on imminent warning rear lighting and signaling,” *Human Factors*, vol. 48, no. 3, pp. 615–626, 2006.

- [13] NHTSA, “The 100 car naturalistic driving study - phase-ii,” 2006.
- [14] NHTSA, “The 100 car naturalistic driving study - phase-i,” 2002.
- [15] J. Voevodsky, “Evaluation of a deceleration warning light for reducing rear-end automobile collisions.,” *Journal of Applied Psychology*, vol. 59, no. 3, p. 270, 1974.
- [16] C. J. Kahane, *The long-term effectiveness of center high mounted stop lamps in passenger cars and light trucks*. National Highway Traffic Safety Administration, 1998.
- [17] J. D. Bullough, P. R. Boyce, A. Bierman, K. M. Conway, K. Huang, C. P. O’Rourke, C. M. Hunter, and A. Nakata, “Response to simulated traffic signals using light-emitting diode and incandescent sources,” *Transportation Research Record*, vol. 1724, no. 1, pp. 39–46, 2000.
- [18] J. D. Bullough, J. V. Derlofske, and H. Yan, “Evaluation of automotive stop lamps using incandescent and sweeping neon and led light sources,” in *SAE Paper 2001-01-0301, Warrendale, PA: Society of Automotive Engineers.*, pp. 12–19, SAE International, 2001.
- [19] M. Sivak, M. J. Flannagan, T. Sato, E. C. Traube, and M. Aoki, “Reaction times to neon, LED, and fast incandescent brake lamps.,” *Ergonomics*, vol. 37 6, pp. 989–94, 1994.
- [20] M. Flannagan and M. Sivak, “An improved braking indicator,” *SAE Transactions*, pp. 284–288, 1989.
- [21] Y.-K. Wang, T.-P. Jung, and C.-T. Lin, “Theta and alpha oscillations in attentional interaction during distracted driving,” *Frontiers in Behavioral Neuroscience*, vol. 12, p. 3, 2018.
- [22] G. Markkula, J. Engström, J. Lodin, J. Bårgman, and T. Victor, “A farewell to brake reaction times? kinematics-dependent brake response in naturalistic rear-end emergencies,” *Accident Analysis Prevention*, vol. 95, pp. 209 – 226, 2016.
- [23] G. V. Barrett, “Feasibility of studying driver reaction to sudden pedestrian emergencies in an automobile simulator,” *Human Factors*, vol. 10, no. 1, pp. 19–26, 1968.
- [24] H. Jeong and P. Green, “Forward collision warning modality and content: A summary of human factors studies,” tech. rep., Technical Report UMTRI-2012-35, 2012.
- [25] N. Schweitzer, Y. Apter, G. Ben-David, D. G. Liebermann, and A. Parush, “A field study on braking responses during driving. ii. minimum driver braking times,” *Ergonomics*, vol. 38, no. 9, pp. 1903–1910, 1995.
- [26] A. Sonnleitner, M. S. Treder, M. Simon, S. Willmann, A. Ewald, A. Buchner, and M. Schrauf, “EEG alpha spindles and prolonged brake reaction times during auditory distraction in an on-road driving study,” *Accident Analysis & Prevention*, vol. 62, pp. 110–118, 2014.

- [27] I.-H. Kim, J.-W. Kim, S. Haufe, and S.-W. Lee, “Detection of braking intention in diverse situations during simulated driving based on eeg feature combination,” *Journal of Neural Engineering*, vol. 12, no. 1, p. 016001, 2014.
- [28] L. G. Hernández, O. M. Mozos, J. M. Ferrández, and J. M. Antelis, “EEG-based detection of braking intention under different car driving conditions,” *Frontiers in Neuroinformatics*, vol. 12, p. 29, 2018.
- [29] Y.-C. Hsiao, H. Kitagawa, and J. Watada, “Studies on eye tracking and brainwave measurement,” in *2015 10th Asian Control Conference (ASCC)*, pp. 1–6, IEEE, 2015.
- [30] S. Mouli and R. Palaniappan, “Eliciting higher SSVEP response from LED visual stimulus with varying luminosity levels,” in *Proc. International Conference for Students on Applied Engineering (ICSAE)*, pp. 201–206, 2016.
- [31] S. Mouli, R. Palaniappan, I. P. Sillitoe, and J. Q. Gan, “Quantification of SSVEP responses using multi-chromatic LED stimuli: Analysis on colour, orientation and frequency,” in *Proc. 7th Int. IEEE Conf. Computer Science and Electronic Engineering Conference (CEEC)*, pp. 93–98, 2015.
- [32] J. Bullough, M. Rea, R. Pysar, H. Nakhla, and D. Amsler, “Rear lighting configurations for winter maintenance vehicles,” in *IESNA Annual Conference: Ottawa, ON, Canada*, pp. 87–94, 2001.
- [33] ROSPA, “The royal society for the prevention of accidents,” 2018.
- [34] W. Young and W. Wilson, “Efficient electric vehicle lighting using LEDs,” in *Southcon/96 Conference Record*, pp. 276–280, IEEE, 1996.
- [35] N. K. Greenwell, “Effectiveness of LED stop lamps for reducing rear-end crashes: Analyses of state crash data,” tech. rep., 2013.
- [36] S. Mouli and R. Palaniappan, “Radial photic stimulation for maximal EEG response for BCI applications,” in *2016 9th International Conference on Human System Interactions (HSI)*, pp. 362–367, 2016.
- [37] S. Mouli, R. Palaniappan, I. P. Sillitoe, and J. Q. Gan, “Performance analysis of multi-frequency SSVEP-BCI using clear and frosted colour LED stimuli,” in *Proc. 13th Int. IEEE Conference on BioInformatics and BioEngineering*, pp. 1–4, 2013.
- [38] S. Pal, D. Mallikarjunareddy, S. Saha, and A. Sharma, “Design and develop a novel brake lighting mechanism for intensity of braking: automobile applications,” *Materials Today: Proceedings*, vol. 5, no. 5, Part 2, pp. 13069 – 13078, 2018. International Conference on Materials Manufacturing and Modelling, ICMMM - 2017, 9 - 11, March 2017.
- [39] N. Huda, S. Kaleg, A. Hapid, M. Kurnia, and A. Budiman, “The influence of the regenerative braking on the overall energy consumption of a converted electric vehicle,” *SN Applied Sciences*, vol. 2, 03 2020.

- [40] A. J. Godfrey and V. Sankaranarayanan, “A new electric braking system with energy regeneration for a bldc motor driven electric vehicle,” *Engineering Science and Technology, an International Journal*, vol. 21, no. 4, pp. 704–713, 2018.

Appendix A - Brake Light Trends

Recently, German car manufacturers Audi and BMW started designing car brake light modules with Organic LED (OLED) based panels, which are completely different from the technology used in LED light arrays. Those panels are fully customisable for colour, shape, pattern, etc. Figures 37, 38, 39, and 40 show various design concepts from those manufacturers. While cars with those specific types of brake panel have yet to appear on the roads, they could be popular in the future given that OLEDs are likely to become much cheaper in the future.



Figure 37: OLED Panel Audi (AUDI, 2018)



Figure 38: OLED Panel Audi Exploded view (AUDI, 2018)



Figure 39: OLED Panel Audi (AUDI, 2018)

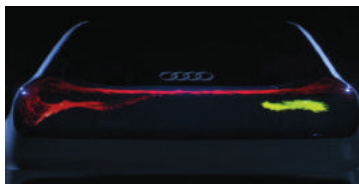

Figure 40: OLED Panel Audi (showing full panel) (AUDI, 2016)

Appendix B - Regenerative Braking

Regenerative braking is an energy recapture mechanism allows slow down the vehicle by converting the kinetic energy into other useful energy that could be stored until required [38]. Regenerative braking concept is a major part of electric vehicle and the primary function is to slow down the vehicle. This concept is becoming more popular due to the higher demand and production of electrical vehicles. Depending on the car manufacturers specification the brake lights automatically come on based on the rate of deceleration without pressing the brake pedal [39]. The amount of energy generated by the regenerative braking system could also be linked with the level of brake pedal depression [40]. The brake depression level could also be used as an indicator to show the intensity of braking by varying the illumination level of brake lights.

There is a fair amount of literature relating to vehicle brake lights, reaction times, and various kinds of bulb, shape and pattern, but little research relating to the perception of these, and in particular the brain response. Furthermore, we have been unable to identify literature relating to the rate, duty cycle and dynamic shape or pattern of lights and their effect on human perception. On the other hand, the cost benefits of LEDs, allied with their power efficiency, flexibility and reliability, have made them increasingly attractive to automotive manufacturers. We are highly likely to encounter more unusual patterns, shapes, and LED deployments in future.

Appendix C - Hardware Setup and Experimental Paradigm (in detail)

Hardware Setup - Pilot Study

The experimental study required EEG data collection, time stamps for brake light ‘ON’ events, and time stamps for brake pedal press events. To meet these requirements, we developed a custom hardware platform with multiple event marker generation using a 32-bit microcontroller. The design was revised several times to accommodate additional requirements while performing trial experiments. A driving environment was simulated using a video (specifically <https://www.youtube.com/watch?v=qm0yhtBHIi0>), projected behind the brake lights. The firmware was developed for generating 35 to 40 random brake light events within a time duration of five minutes. Figure 41 shows the hardware functional blocks for event generation, event trigger and EEG recording. Other than the microcontroller, the hardware has a MOSFET driver circuit to activate the currently installed brake light whenever a brake light event is generated, with a working voltage of 13.5v DC. Four different event triggers are programmed in the microcontroller, based on the input received from the pedals and simulation. A brake light trigger is generated and transferred to the EEG stream as an event, corresponding to when the microcontroller outputs a random pulse for energising the brake lights. The pedals operation events are also sent as triggers in the EEG stream whenever the participant performs an action.

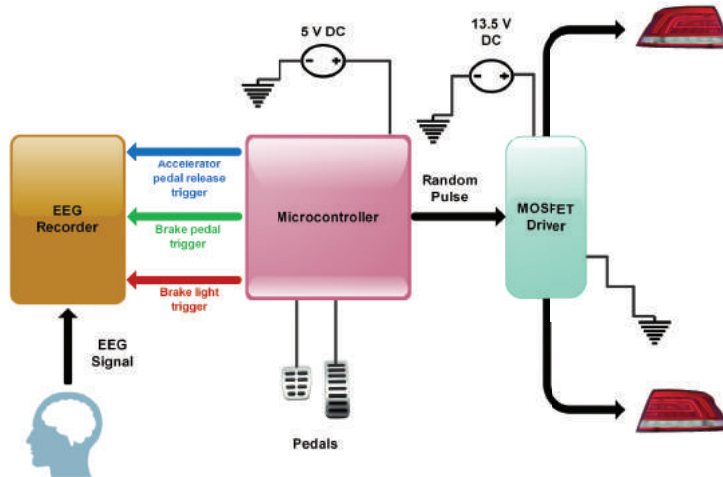

Figure 41: Control blocks for generating brake light events

Figure 41 also shows the hardware used for simulating the brake light events and triggers during pilot study. The system was externally powered using a stabilised power supply for continuous operation throughout the experimental procedure. The foot pedals used for the experiment are shown in Figure 42, which are heavy duty single-pole-double-throw (SPDT) switches wired to the controller board.



Figure 42: Pedal board

Hardware Schematic and Design

The core of the hardware is the microcontroller, which is a Cortex M4, with a clock speed of 72 MHz. It has multiple input/output ports, which are programmed for the experimental requirements. The hardware design has gone through many iterations with trial experimental recordings. The initial hardware design scheme (version 1.1) is shown in Figure 43, and consists of a single marker sent to the EEG recording system. The brake light simulation consists of left, right and the centre high mount stop lamp (CHMSL). The data recording platform was based on BioSemi, which accepts only one USB trigger channel.

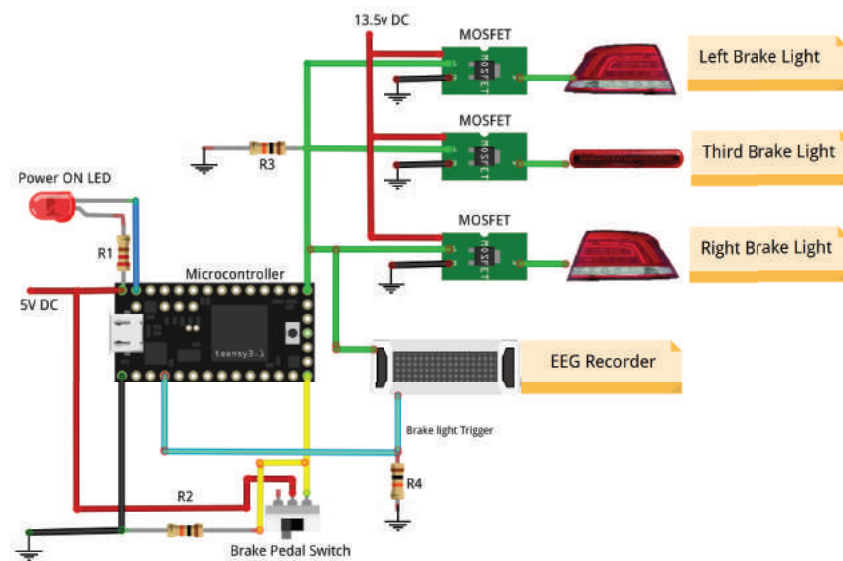

Figure 43: Brake light simulator and event marker prototype version 1.1

Experimental data recorded with the single trigger was unable to set time stamps for the brake pedal press events for the corresponding random brake light events. For this reason, the EEG recording platform was changed to OPENBCI from BioSemi for more hardware flexibility in design. The OPENBCI platform has five individual input digital trigger channels, which can record each trigger separately along with the EEG stream. Trigger time stamps are recorded for all the trigger events simultaneously and the recorded data can then be analysed with higher accuracy.

For use with OPENBCI, the hardware platform was improved as shown in Figure 44, to include additional trigger data from the brake pedal activation along with the EEG stream. Trial data recorded using this platform could identify the time delay between the brake light activation and when the user engages the brake pedal. The trial study also observed that with the CHMSL the real performance of different brake lights could not be evaluated with precision, and it was therefore excluded from further trials.

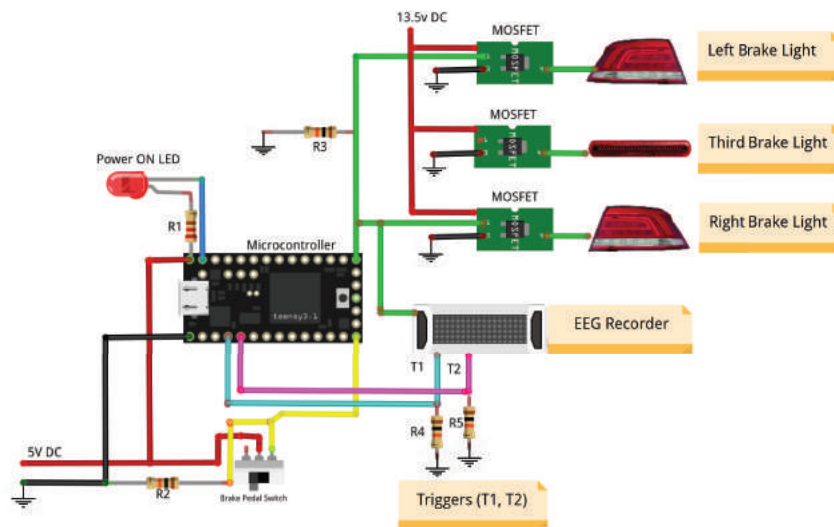

Figure 44: Brake light simulator and event marker prototype version 1.2

Following analysis of trial recordings, it was decided to introduce two pedals to more accurately simulate real driving conditions – where a participant will typically lift their foot from the accelerator pedal before engaging the brake pedal. The hardware was updated to include one more trigger, and the firmware developed accordingly. The trials recorded with the improved design include three trigger channels (namely: brake light active, brake pedal pressed, and accelerator released). These new triggers can identify when the brake light is active as well as the time delays (reaction time) in lifting the foot from the accelerator and pressing the brake light. Figure 45 shows the update hardware. The cognitive responses for each set of lights were recorded in two sessions, one with the pedal action and the second just observing the lights. For the second session, an additional marker was required to ensure the correct time stamp for the start instance of the experiment to precisely define the EEG data length for analysis. This was achieved by using the accelerator press instance and assigning that as a trigger to be included in the EEG stream. The first instance of this trigger would be taken as the start of the experiment time stamp when the data is analysed. The hardware was modified for the additional trigger as shown in Figure 46 and the firmware was developed for the required time stamps.

Figures 47 and 48 show the events from all four channels. The recorded data can be examined to identify the time delay between the brake light event and brake pedal activation in the simulation. The four columns shown receive the triggers from the hardware which are marked in different colours based on the events received. The first column records the trigger stamp when brake lights are energised. From Figure 47, the brake lights are active yet for a few milliseconds, the brake pedal is not activated. The

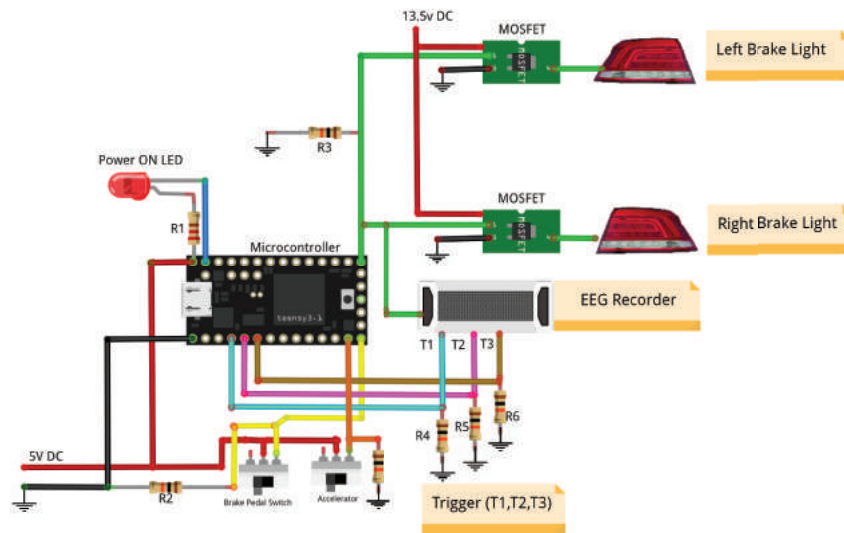

Figure 45: Brake light simulator and event marker prototype version 1.3

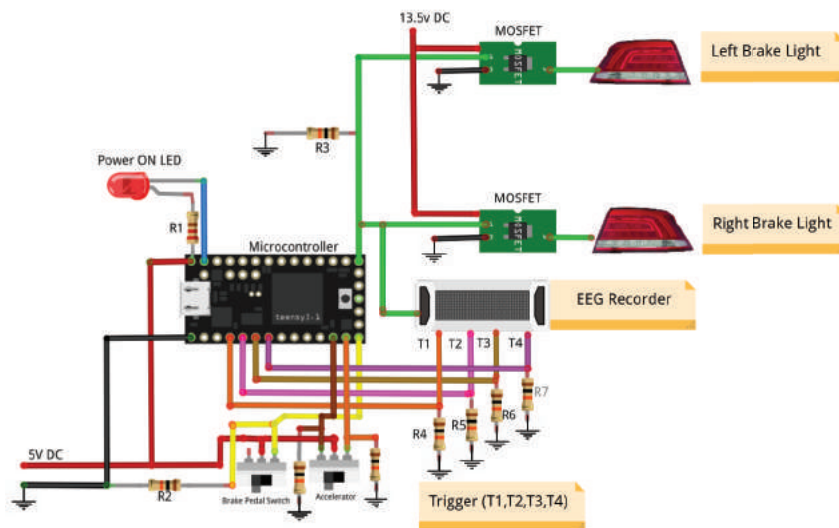

Figure 46: Brake light simulator and event marker prototype version 1.4

reaction time delay for physically engaging the brake pedal can be calculated between the first trigger stamp of the brake light activation and the time stamp when the brake pedal pressed event occurs. From Figure 48, the brake light is active for a few milliseconds, and the participant did not release the accelerator immediately. We attribute this delay to the time required to energise the incandescent brake light bulb, which activates much slower than in an LED system.

Apart from the brake light simulation and event markers, we assessed brake lights from different manufacturers. Brake lights from various car manufacturers differ in the wiring cluster, which are mainly controlled through the *CAN* bus. The wiring harness and control cannot be interfaced directly to the existing microcontroller for generating brake light events. For this experimental study, a custom interface was built to accommodate various types of LED brake light clusters, which were controlled via the microcontroller. The brake lights used for this study have a working voltage of 13.5v DC which was

a high-current fast switching *MOSFET* (switching time less than 17ns) to minimise any working delay. Each brake light requires one *MOSFET* based driver circuit. The revision four hardware prototype used for the pilot study is shown in Figure 49.

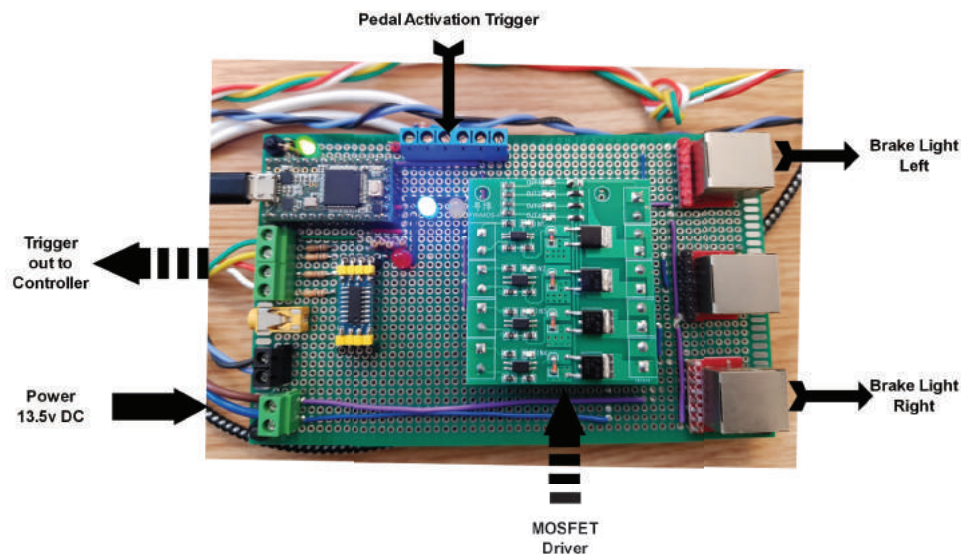

Figure 49: Event trigger data with delayed reaction time

The peripheral devices were wired directly to the prototype board. The pedal switches were mounted on an inclined wooden board as shown in Figure 42 and wired to the control board. From the brake pedal, only the brake press instance event is recorded, whereas from the accelerator pedal both press and release events are recorded. The four trigger event outputs from the microcontroller were connected to the OPENBCI platform to be recorded along with the EEG readings.

EEG electrode setup

For the data collection, EEG information was recorded using eight channels based on the standard 10/20 system with channels highlighted in Figure 50. The midline channels Fz, Cz, Pz and Oz along with F3, F4, C3 and C4 were used with ground and reference on both ears (based on previous research studies in this area [28]). The electrodes used were gel based, and the impedance was kept below 5kOhm throughout the experiment. The recording hardware used was based on OPENBCI, which can record up to 16 channels simultaneously with a sampling rate of 250 Hz. The OPENBCI platform is highly customisable for hardware interfaces as compared to other commercial systems and can take up to five different digital input triggers, which was one of the main requirements for this experimental study. Each trigger channel is stored as a separate column along with the recorded data. The event markers are stored as '1' for an active event when the event was triggered as shown in Figures 47 and 48.

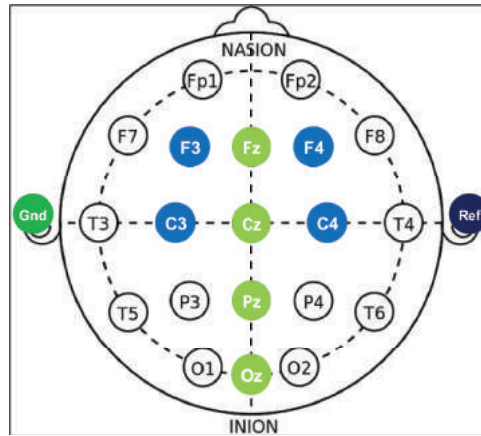

Figure 50: EEG electrode layout

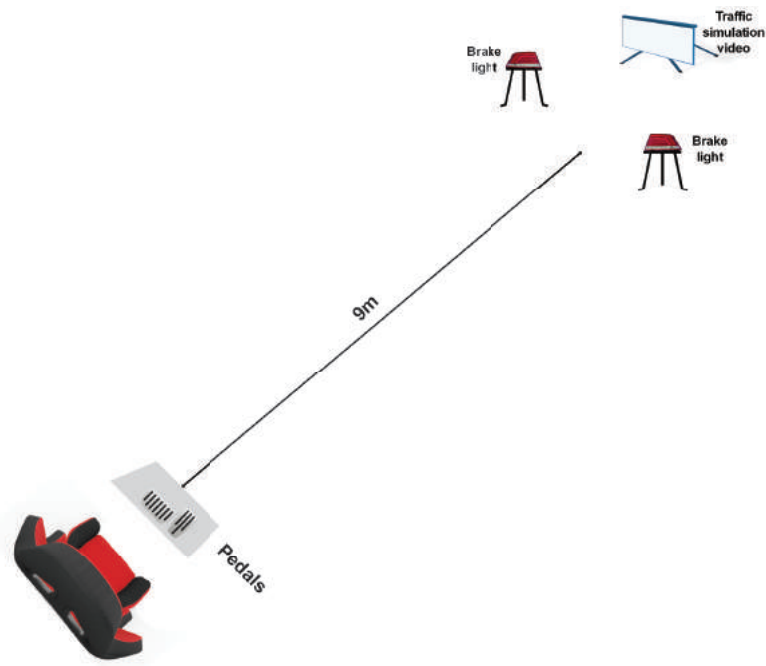

Figure 51: Experimental layout

Experimental paradigm

For the simulation of brake lights, the brake lights were fitted on two adjustable stands equipped with small wooden mounting platforms of adjustable height. The lights were separated with an inner end-to-end distance of 120 cm, and at a height of 100 cm for all the different brake lights used in the experiment. A motorway video was projected along with sound behind the lights for road traffic simulation. Each participant was seated 9m from the brake lights in a daylight setup as shown in Figure 51. The connection for the brake lights was designed to be modular to quickly swap the light assemblies to a different pair during the experiment. Participants were asked to count the number of bridges during their simulated journey, or the number of different colour cars or the

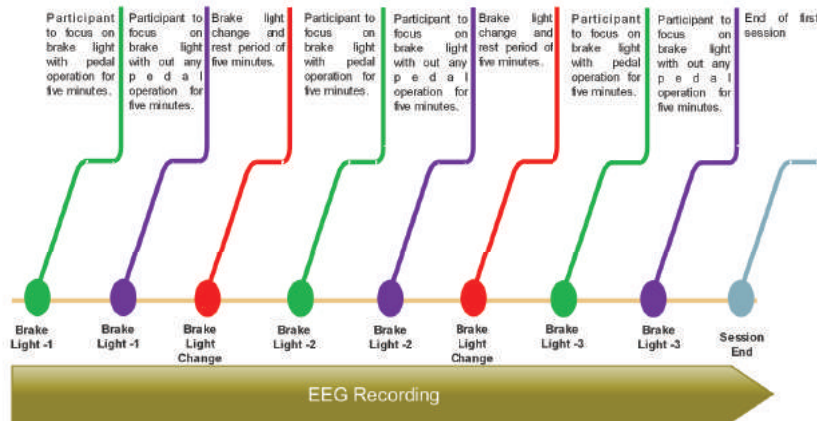

Figure 52: Experimental protocol

number of direction markings, which appeared during the simulation video. The aim was to keep their attention on the road while the brake lights activated at random intervals.

The experimental protocol is shown in Figure 52. Each recording session lasted 5 minutes for each pair of brake lights, which were chosen in a random order. The participants were chosen from expert and novice drivers, between 18 and 60 years with a mean age of 30.5 and $SD \pm 10.1$. Ethical approval for this study was granted by the Faculty of Sciences Ethics committee at the University of Kent.



Figure 53: Simulation and data recording

To start the experiment, a participant was comfortably seated as in Figure 53 and the pedal board placed at a convenient distance from the chair. The EEG cap was fitted, and the electrodes wired to the selected locations. Electrode gel was applied, and the impedance was checked using the EEG recording software. The required trigger lines were checked for the correct function. The session started with a selected pair of brake lights mounted on the stand, and the hardware activated for the simulation while the EEG was recorded. During the first five-minute simulation, the participant operated the pedals whenever the brake lights were illuminated. An event marker was sent to the EEG software when the participant pressed the accelerator, and this event was taken as the start of the session. This was followed by a two-minute break, and the simulation continued for another five minutes while the participant sits idle after

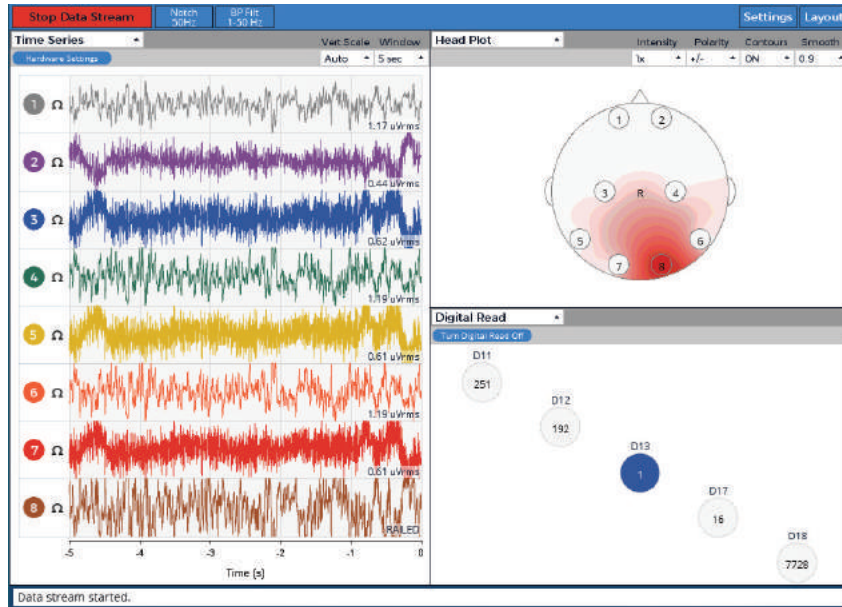

Figure 54: Sample EEG recording

pressing the accelerator for initiating the start event, while the brake light illuminates randomly. After a break of five minutes, another pair of brake light were mounted, and the experiment was repeated. The sample EEG recording, and the digital event markers are shown in Figures 54 and 55.

EEG Channels (μV)								Trigger Channels			
Fz	Cz	Pz	Oz	F3	C3	F4	C4	Brake Light Active	Brake Pedal Pressed	Accelerator Released	Accelerator Pressed
5477.83	9182.34	6613.95	3514.52	4869.39	7122.74	8404.9	5867.98	1	0	1	0
5487.55	9190.57	6649.93	3536.14	4887.52	7169.41	8415.88	5883.03	1	0	1	0
5402.22	9148.84	6630.18	3507.75	4841.48	7196.46	8344.42	5844.89	1	0	1	0
5317.21	9104.45	6579.39	3459.16	4785.44	7175.87	8265.32	5787.74	1	0	1	0
5365.16	9126.02	6563.95	3461.68	4801.06	7123.32	8302.85	5801.19	1	0	1	0
5484.07	9185.7	6617.14	3521.74	4871.18	7125.24	8413.11	5871.98	1	0	1	0
5486.32	9187.48	6647.9	3538.59	4881.31	7168.83	8421.76	5832.4	1	0	1	0
5401.37	9145.73	6628.95	3508.89	4838.44	7197.24	8339.57	5841.02	1	0	1	0
5314.33	9098.57	6577.81	3458.55	4781.44	7172.58	8254.48	5783.42	1	0	1	0
5358.18	9117.81	6561.2	3457.61	4794.72	7116.24	8291.65	5791.29	1	0	1	0
5479.89	9183.75	6618.55	3516.67	4870.24	7125.56	8409.69	5863.35	1	0	1	0
5491.44	9195.26	6657.33	3541.19	4891.37	7179.18	8424.69	5883.74	1	1	1	0
5403.96	9151.32	6633.35	3504.22	4844.94	7204.15	8341.25	5837.81	1	1	1	0
5319.47	9107.02	6580.78	3456.16	4789.29	7178.24	8258.61	5780.97	1	1	1	0
5371.03	9132.14	6568.19	3463.38	4808.64	7126.18	8306.49	5793.11	1	1	1	0
5495.65	9199.04	6627.02	3525.59	4886.63	7136.11	8426.09	5874.98	1	1	1	0
5500.05	9202.73	6658.12	3541.16	4903.1	7184.39	8437.02	5890.89	1	1	1	0
5399.15	9147.23	6624.27	3498.79	4844.47	7198.74	8343.86	5835.64	1	1	1	0
5307.87	9098.9	6568.57	3447.22	4780.28	7168.05	8252.98	5775.61	1	1	1	0
5352.08	9117.59	6552.03	3447.11	4792.64	7108.75	8292.34	5784.59	1	1	1	0
5472.24	9181.94	6610.73	3509.13	4866.51	7117.47	8405.69	5859.04	1	1	1	0
5484.02	9194.52	6654.25	3538.57	4887.95	7175.25	8421.33	5885.01	1	1	1	0
5392.81	9147.58	6629.48	3500.19	4837.54	7198	8338.97	5839.35	1	1	1	0
5304.85	9096.56	6570.83	3440.45	4775.43	7166.37	8256.87	5777.01	1	1	1	0

Figure 55: Sample EEG data and event markers

The recorded EEG signal was processed based on the four trigger stamps for analysing the cognitive responses for different types of brake lights. For the analysis, thirty random

brake light events were considered for both trials from each set of brake light simulations, one with the participant activating the brake pedal and the second, while the participant was sitting idle observing the lights flash randomly.

Data Analysis (Pilot study)

The data analysis was carried out in two ways, firstly, with respect to timing information and subsequently with respect to EEG information. In the first case, the reaction time latencies evoked by the different brake lights were calculated between three pairs of events: brake light activation and accelerator release, accelerator release and brake pedal pressing, and brake light activation and brake pedal pressing. These were employed to draw a comparison between the three types of brake lights used in the experiments, namely Audi LED, Ford Bulb, and Ford LED. The Wilcoxon test for statistical significance was used to compare the brake lights in sets of two. The initial hypothesis was that the Ford bulb brake light would be the least efficient, resulting in higher reaction times than the other two. The results follow in the next section.

The EEG analysis was conducted with reference to the P300 wave, an event related potential component (ERP) which emerges approximately 300ms after a subject is exposed to a stimulus. The P300 is meaningful in the context of brake light testing, as it indicates conscious perception and categorisation of a stimulus and can be thus used as a measure of how prompt and impactful each brake light is. After high pass and low pass filtering of the EEG data (at 0.5 and 8 Hz respectively), the timing and amplitude of the P300 events were computed. The mean signal from 200ms prior to each brake light onset was calculated and subtracted from a 1s epoch following the brake light onset. The resulting signals were subjected to peak detection, with each peak corresponding to a P300 event. The timing and amplitude of these events were calculated and used in the analysis. The Wilcoxon test for statistical significance was applied on both measures. The data included in this analysis was extracted from two experimental conditions, one where the subject was instructed to press the brake pedal as soon as the brake light is on, and the other where the subject was instructed to abstain from movement and only observe the brake lights in an attentive manner. The hypothesis here is that more efficient brake lights will induce shorter latencies and higher amplitudes, both in the brake pedal pressing condition and in the attention-only condition. Again, the Ford Bulb light was expected to be outperformed by the LED light units. Unfortunately due an issue in the trigger, the EEG data was not usable. Hence, we present here the results of the timing analysis from the pilot study only.

Results - Pilot study

Latency between brake light activation and accelerator release: Table 7 features the mean latency values for each participant across the three brake light conditions: Audi LED, Ford Bulb, and Ford LED. Each latency is calculated as the time interval between the brake light onset and the moment the accelerator is released by the participant. All values are represented in seconds (with the recording sample rate being 250 Hz). Figure

56 is a graphic illustration of the contents of this table. As it can be seen, for most participants, the Ford Bulb light produced the higher latencies, with the two LED lights exhibiting similar values across all participants, with the Audi LED unit being in the lead for half the instances, and the Ford LED unit being in the lead for the other half. Table 8 presents the results from the Wilcoxon test for statistical significance comparing pairs of conditions across participants. A 5% criterion was applied to determine cases where the first of the two conditions elicited a significantly higher value, and a 95% criterion were applied to determine cases where the second condition elicited the significantly higher outcome. Values in bold correspond to the 5% criterion, and highlighted values to the 95% criterion. The Ford Bulb appeared to produce significantly higher latencies than the Audi LED in 8 out of 10 cases, and significantly higher latencies than the Ford LED in 9 out of 10 cases. This agrees with the initial hypothesis. Moreover, in 4 out of 10 participants, the Ford LED produced significantly higher values than Audi LED, while the reverse only occurred for one participant.

Table 7: Mean Latency between brake light activation and accelerator release (in seconds)

Mean Latency	Audi LED	Ford Bulb	Ford LED
Participant 1	0.43	0.67	0.38
Participant 2	0.29	0.37	0.32
Participant 3	0.35	0.39	0.44
Participant 4	0.95	0.7	0.57
Participant 5	0.36	0.48	0.37
Participant 6	0.39	0.49	0.37
Participant 7	0.4	0.49	0.44
Participant 8	0.56	0.36	0.3
Participant 9	0.4	0.53	0.43
Participant 10	0.6	0.49	0.38

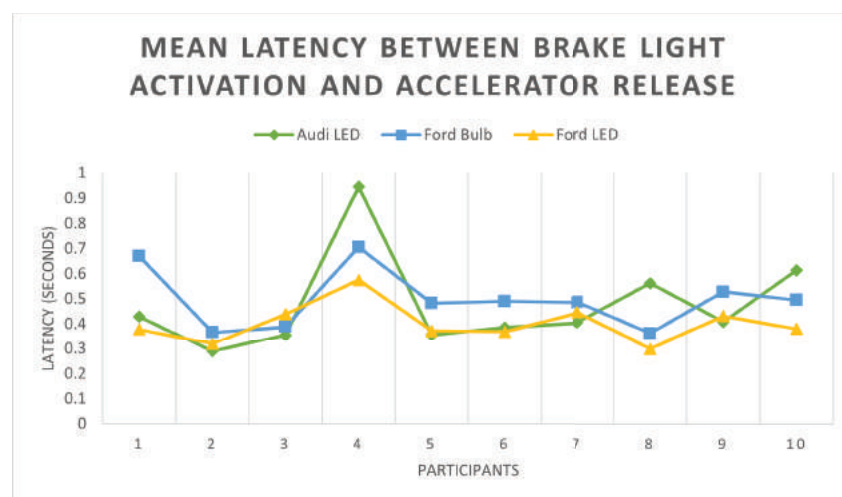

Figure 56: Mean latency between brake light activation and accelerator release

Latency between accelerator release and brake pedal pressing: Similarly, to the previous section, Table 9 presents the mean latency values for each participant across the three brake light conditions, while Figure 57 is a graphic representation of them. This time, each latency is calculated as the time interval between the moment the accelerator is released, and the brake pedal is pressed by the participant. Table 10 again displays statistical significance results. As it is observed, there is no pattern of high latencies

Table 8: Statistical significance (p-value) of brake light activation and accelerator release

Statistical Significance	Audi LED Vs Ford Bulb	Audi LED Vs Ford LED	Ford Bulb Vs Ford LED
Participant 1	9.9E-01	9.6E-01	1.2E-03
Participant 2	1	9.1E-01	9.5E-03
Participant 3	9.8E-01	2E-01	5.3E-03
Participant 4	5.7E-01	4.7E-01	4.4E-01
Participant 5	1	9.9E-01	4.5E-08
Participant 6	1	1.3E-01	6.2E-06
Participant 7	9.9E-01	9.9E-01	6.5E-03
Participant 8	9.9E-01	0.6E-01	0.3E-03
Participant 9	9.9E-01	9.8E-01	3.7E-03
Participant 10	9.4E-01	1.3E-03	5.9E-07

Table 9: Mean Latency between accelerator release and brake pedal pressing (in seconds)

Mean Latency	Audi LED	Ford Bulb	Ford LED
Participant 1	0.57	1	0.73
Participant 2	0.71	1.19	0.84
Participant 3	0.26	0.29	0.52
Participant 4	0.76	0.65	1.59
Participant 5	0.34	0.42	0.37
Participant 6	6.28	1.77	1.64
Participant 7	0.3	0.31	0.31
Participant 8	1.6	0.31	0.72
Participant 9	0.37	0.4	0.46
Participant 10	1.6	0.48	0.77

attributed to any one specific condition, with 3 participants exhibiting higher values for Audi LED, 3 participants exhibiting higher values for Ford Bulb, and the remaining 4 participants displaying higher values for Ford LED. Statistical significance revealed no pattern either, with most pairs showing significant differences, which balance each other out. These results could be interpreted as a lack of effect (specific to the type of brake light) on the execution of the braking action, indicating that it is the interval between the brake light activation and accelerator release, which makes all the difference when it comes to prompt braking.

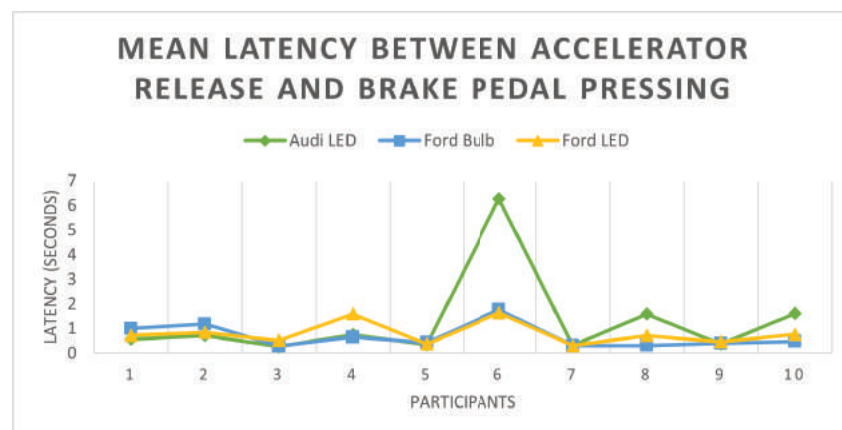

Figure 57: Mean latency between accelerator release and brake pedal pressing

Latency between brake light activation and brake pedal pressing: Finally, Tables 11 and 12 as well as Figure 58, present the same relationships as those in the previous two sections did, only in this case the featured values correspond to the time interval between the moment of brake light onset and the moment of brake pedal pressing by the participants. Here, the way the mean latencies relate to each other mirrors that in the previous section, with 5 out of 10 participants displaying the highest values for the

Table 10: Statistical significance (p-value) accelerator release and brake pedal pressing

Statistical Significance	Audi LED Vs Ford Bulb	Audi LED Vs Ford LED	Ford Bulb Vs Ford LED
Participant 1	8.2E-01	9.9E-01	8.5E-01
Participant 2	9E-02	4E-02	2.3E-01
Participant 3	9.9E-01	9.5E-01	1E-02
Participant 4	4.6E-03	9.2E-01	9.9E-01
Participant 5	1	9.9E-01	4.4E-07
Participant 6	7.2E-01	5.3E-01	3E-01
Participant 7	2.4E-01	8.2E-01	9.1E-01
Participant 8	3E-02	4.7E-05	6E-04
Participant 9	9.7E-01	9.9E-01	7.1E-01
Participant 10	6E-01	1.7E-01	3.2E-01

Table 11: Mean Latency between brake light activation and brake pedal pressing (in seconds)

Mean Latency	Audi LED	Ford Bulb	Ford LED
Participant 1	1	1.67	1.1
Participant 2	1	1.55	1.16
Participant 3	0.62	0.68	0.95
Participant 4	1.7	1.36	2.17
Participant 5	0.7	0.91	0.74
Participant 6	6.66	2.26	2.01
Participant 7	0.71	0.79	0.75
Participant 8	2.16	0.67	1.02
Participant 9	0.78	0.93	0.89
Participant 10	2.23	0.97	1.15

Ford Bulb light. The significance test points again to the Ford bulb for higher latencies than both other LED lights, with significantly higher results in 6 participants over Audi LED, and in 8 participants over Ford LED. In addition, latencies evoked by Ford LED were significantly higher than those by Audi LED in the cases of the same 4 participants who have been observed in previous section.

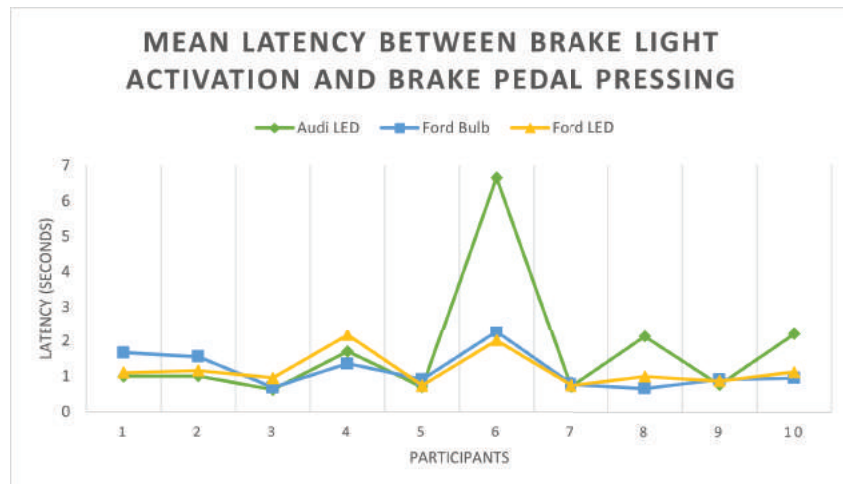

Figure 58: Mean latency between brake light activation and brake pedal pressing

Pilot study conclusion

Overall, these results hint that, as hypothesised, the light unit containing an incandescent bulb is less efficient at evoking a fast braking response than the two LED ones, and

Table 12: Statistical significance (p-value) of brake light activation and brake pedal pressing

Statistical Significance	Audi LED Vs Ford Bulb	Audi LED Vs Ford LED	Ford Bulb Vs Ford LED
Participant 1	9.9E-01	9.9E-01	5.5E-01
Participant 2	9.9E-01	7.4E-01	3.2E-02
Participant 3	9.9E-01	3.8E-01	8.9E-03
Participant 4	2E-02	8.3E-01	9.9E-01
Participant 5	1	9.9E-01	4E-08
Participant 6	7.3E-01	5.6E-01	5E-02
Participant 7	9.9E-01	9.9E-01	9.6E-03
Participant 8	7.6E-01	3E-04	2E-04
Participant 9	9.9E-01	9.9E-01	2.7E-02
Participant 10	9E-01	6E-02	8.9E-03

between the two LED units, the Audi device elicits a faster response, which we hypothesise is due to the longer horizontal light compared to Ford. Moreover, it is observed that the time between seeing the brake light lighting up, and releasing the accelerator, is the critical interval where the different types of lights can influence the speed of braking reaction.

WP2 Main Experiment

In the report, the main experimental hardware platform was reported - this hardware was enhanced with additional functionality to improve the data collection. The primary addition was a set of yellow LED circular distractor rings placed near to the brake lights [1] to improve the elicitation of the P300 component (a type of response we are measuring from the brain, which was found to be weak in the preliminary experiments reported in the second interim report). The response weakness was likely due to the predictable nature of braking simulations in the experiment, i.e. participants could stare directly at the brake lights waiting for them to light up, a situation that would not occur in real life, when drivers would divide their attention much more widely. With the introduction of random flashes generated by the 100mm diameter yellow rings to distract the attention of the participants, the brake light stimulation introduced more unpredictability, as it would in a real-world situation. This was found to improve the strength of the P300 response. The enhanced hardware is shown in Figure 59.

Furthermore, the number of trials for each set of brake lights was increased to 45 - this was to ensure that we would have sufficient clean data (since some may need to be discarded, particularly portions that are contaminated by eye blinks). The time required to complete the test for each set of lights varied between 12 and 18 minutes, and was followed by a rest period of 5 minutes. The hardware platform was also improved to incorporate an LCD screen to display the brake light count (something useful to the person running the test). Figure 60 shows more detail on the improved hardware, including the LCD and the distractor rings. The improved prototype controller is shown in Figure 61 while Figure 62 shows an active distractor rings located near to the brake lights.

An additional marker was required to ensure the correct time stamp for the start instance of the experiment to precisely define the EEG data length for analysis. This

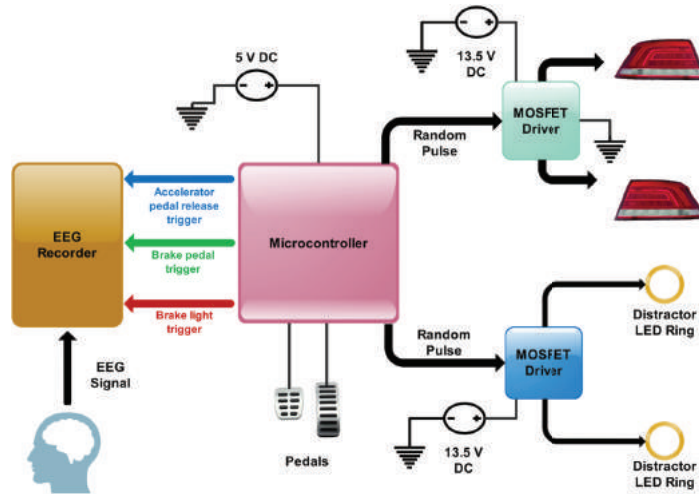

Figure 59: Control blocks for generating brake light events with distractor rings

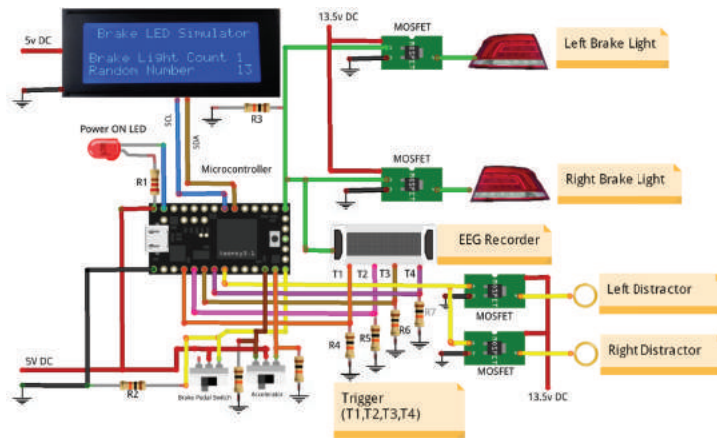

Figure 60: Brake light simulator, event marker and distractor ring prototype version 1.5

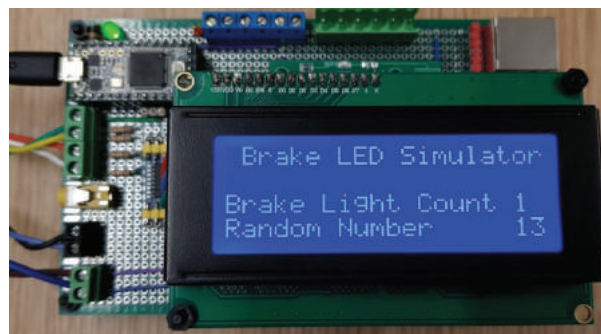

Figure 61: Prototype controller version 1.5

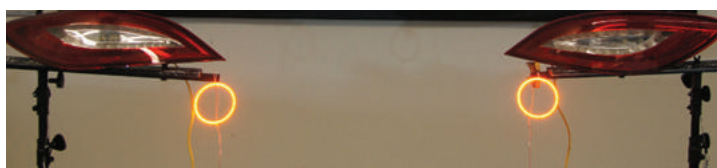

Figure 62: Distractor rings located close to the brake lights

was achieved by using the accelerator press instance and assigning that as a trigger to be included in the EEG stream. The first instance of this trigger would be taken as the start of the experiment time stamp when the data is analysed. The hardware was modified for the additional trigger and the firmware was developed for the required time stamps.

The brake light simulation and event markers tests utilised brake lights from different manufacturers. The brake lights used in this experimental study are Audi (Q5 2016), Fiat (Fiat 500 (312) 2007, LED and Bulb), Ford (Ford focus hatchback 2018, LED and Bulb), Honda (Civic 2015), Mercedes (CLS w218 -2015), Alfa Romeo (Mito hatch 2019), Nissan (Leaf 2010) and Volkswagen (VW Golf 2017). These lights were chosen as they were quite recent and could be found on the road vehicles plus due to their varying shapes and design.

Experimental Paradigm

For the simulation experiment, the brake lights were fitted on two adjustable stands equipped with small wooden mounting platforms of adjustable height. The lights were separated with an inner end-to-end distance of 120cm, and at a height of 100 cm for all the different brake lights used in the experiment. A motorway video was projected, accompanied by sound, behind the lights for road traffic simulation. Each participant was seated 5 m (the feedback from pilot study was that the distance from participants to brake lights was too far) from the brake lights in a daylight setup as shown in Figure 65. The connection for the brake lights was designed to be modular to quickly swap the light assemblies to a different pair during the experiment. Participants were asked to keep count of the number of times the brake lights flashed with the aim of keeping their attention on the road while the brake lights activated at random intervals.

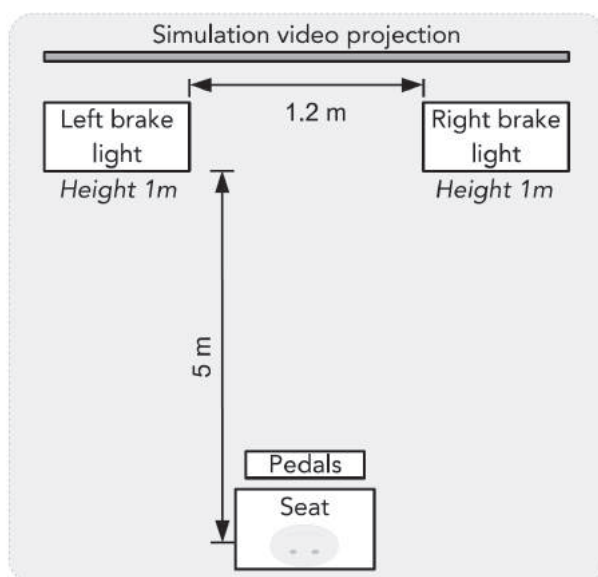

Figure 63: Experimental layout

Ten sets of brake lights from different car manufacturers with distinct light shapes have been used in the experiments. Eight of the light sets employ LEDs, while the remaining



Figure 64: Alpha Romeo LED



Figure 65: Audi LED



Figure 66: Fiat LED



Figure 67: Ford LED



Figure 68: Honda LED



Figure 69: Mercedes Benz LED

two sets employ incandescent bulbs. In order to make the LED/bulb comparison fairer, two same-vehicle model lights with different bulb types were compared, i.e. two sets of Ford and Fiat units with identical exterior shapes, but using different bulb technologies.

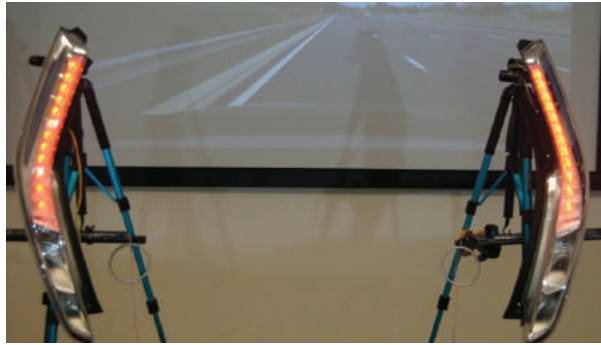

Figure 70: Nissan LED



Figure 71: Volkswagen LED



Figure 72: Fiat Bulb



Figure 73: Ford Bulb

The different brake light models in an active state are shown in Figures 64 - 73. All brake lights from each manufacturer are tested as matching pairs.

Appendix D - Box Plots from all participants combined

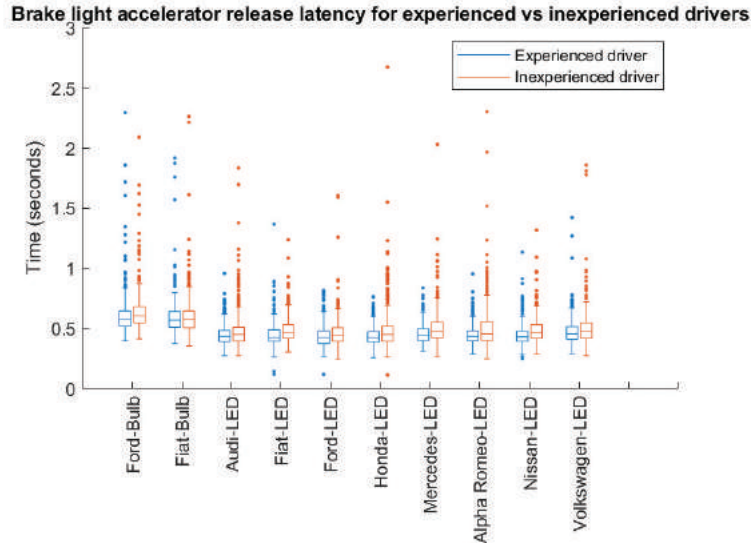

Figure 74: Brake light accelerator release latency (BrakeAcc)

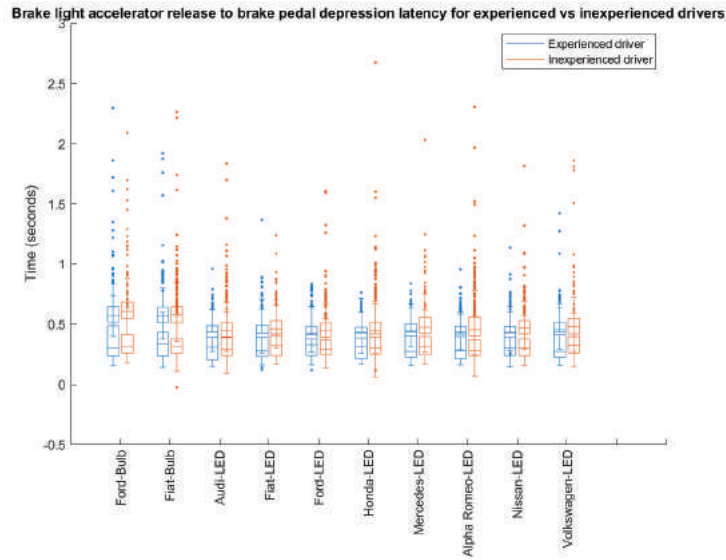

Figure 75: Brake light accelerator release to brake pedal depression latency (AccPdl)

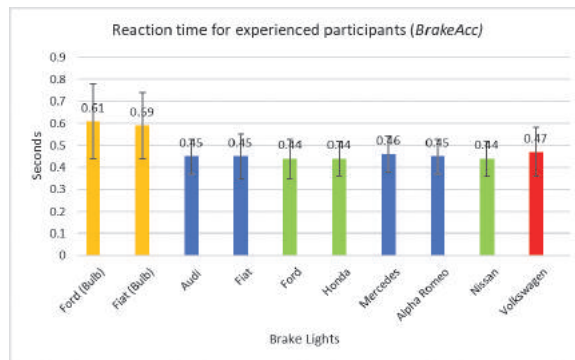

Figure 76: BrakeAcc timings for 11 experienced participants (mean±standard deviation)

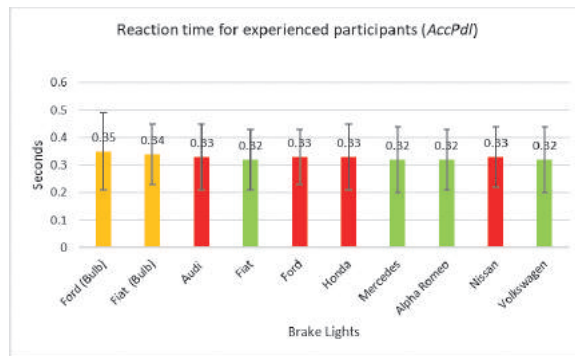

Figure 77: Plot for 11 experienced participants based on AccPdl timings (mean±standard deviation)

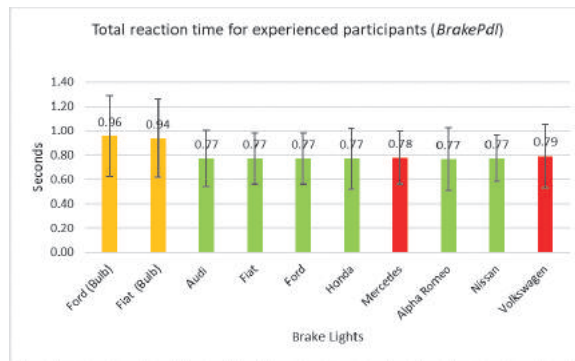

Figure 78: Plot for 11 experienced participants based on total reaction timings (BrakePdl, mean±standard deviation)

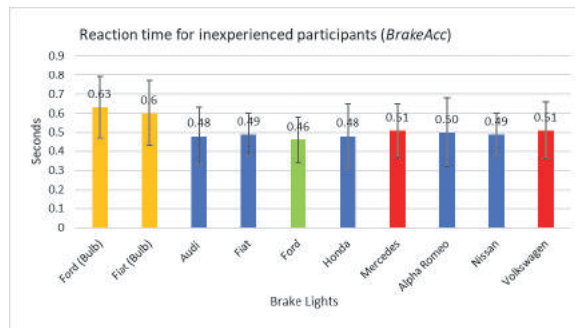

Figure 79: Plot for 11 inexperienced participants timings based on BrakeAcc (mean±standard deviation)

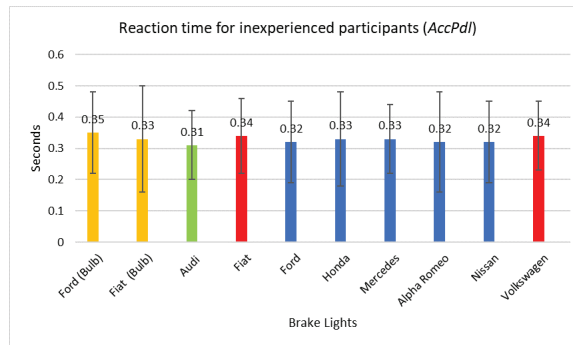

Figure 80: Plot for 11 inexperienced participant timings based on AccPdl (mean±standard deviation)

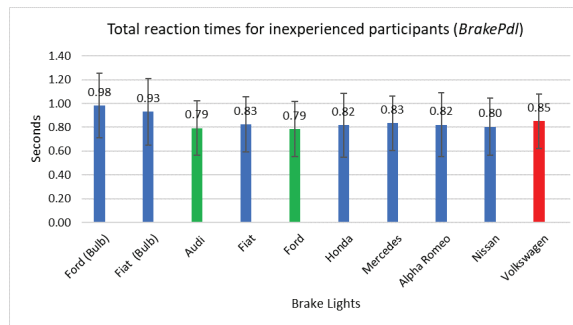

Figure 81: Plot for 11 inexperienced participants based on total reaction times, BrakePdl (mean±standard deviation)

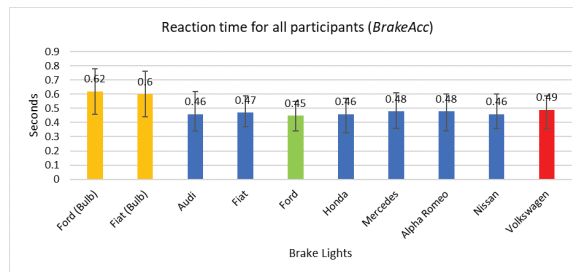

Figure 82: Plot for all 22 participants based on BrakeAcc responses (mean±standard deviation)

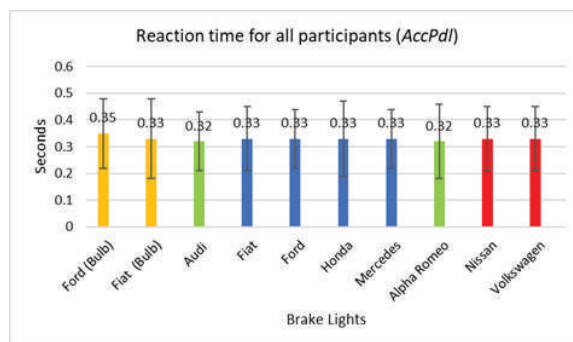

Figure 83: Plot for all 22 participants based on AccPdl timing responses (mean±standard deviation)

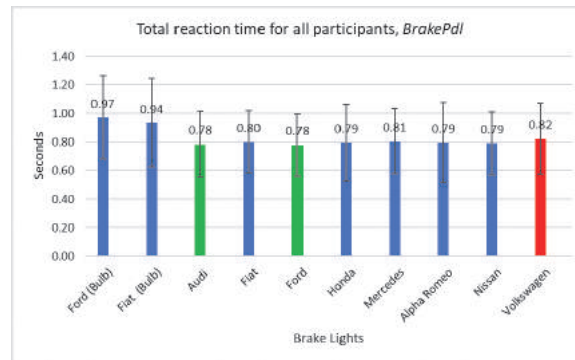

Figure 84: Plot for all participants based on BrakePdl timing responses (mean±standard deviation)

Appendix E - BrakeAcc (plots from all subjects)

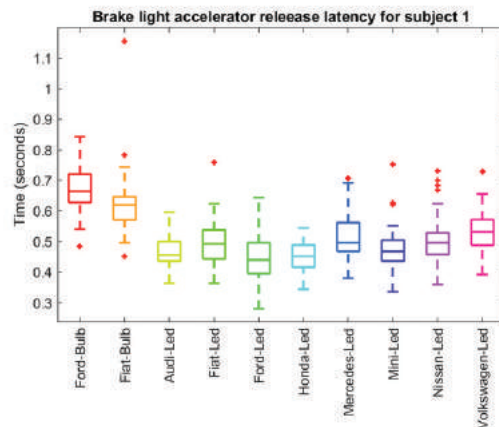

Figure 85: BrakeAcc latency for Subject 1

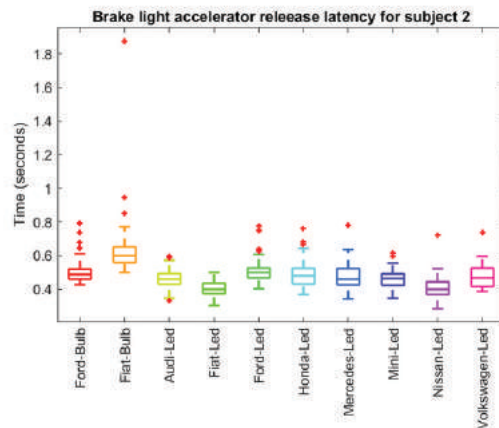

Figure 86: BrakeAcc latency for Subject 2

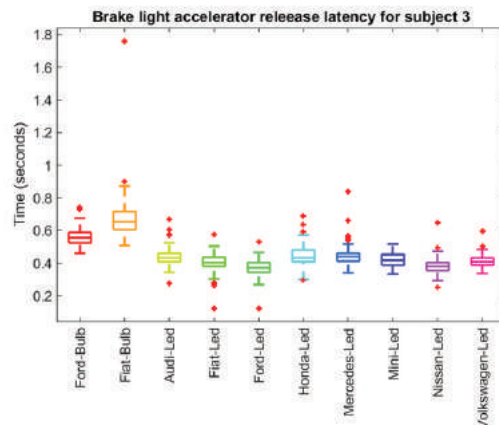

Figure 87: BrakeAcc latency for Subject 3

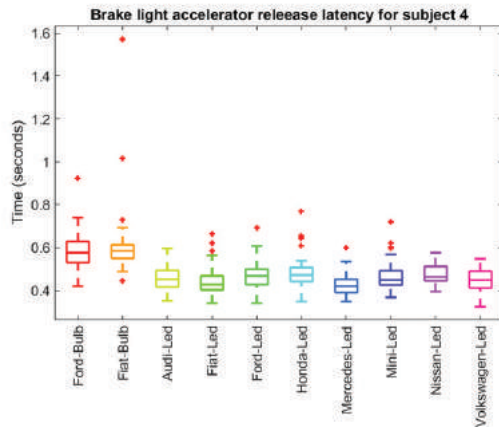

Figure 88: BrakeAcc latency for Subject 4

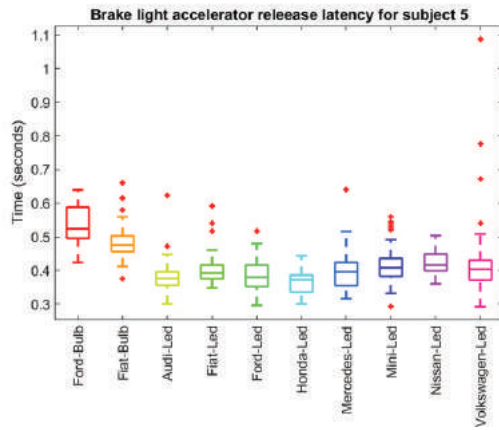

Figure 89: BrakeAcc latency for Subject 5

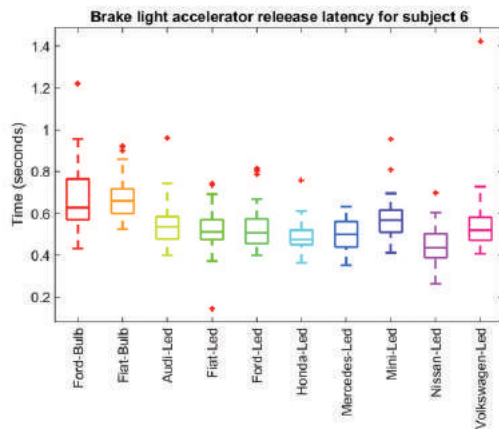

Figure 90: BrakeAcc latency for Subject 6

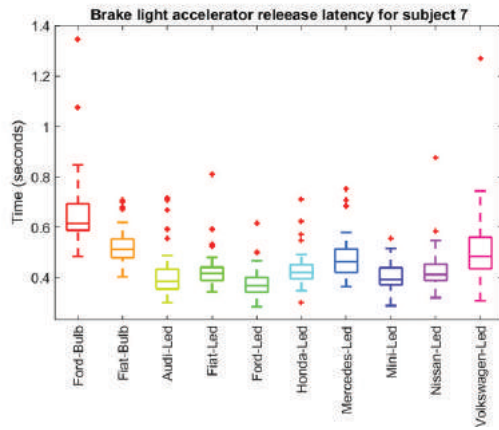

Figure 91: BrakeAcc latency for Subject 7

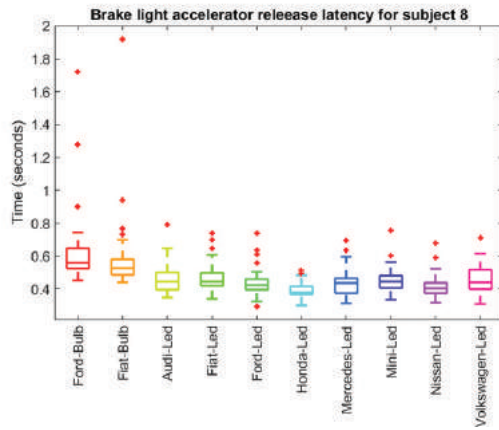

Figure 92: BrakeAcc latency for Subject 8

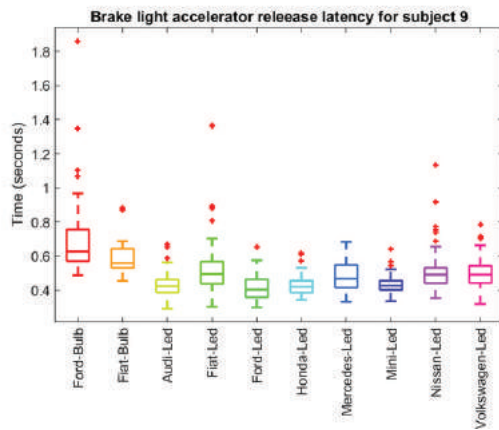

Figure 93: BrakeAcc latency for Subject 9

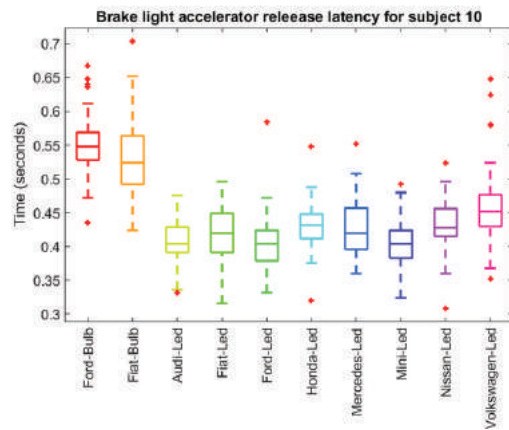

Figure 94: BrakeAcc latency for Subject 10

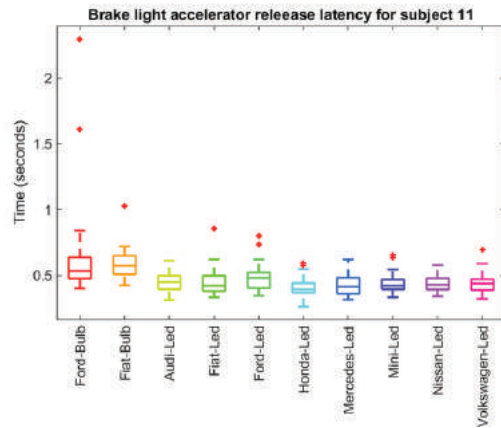

Figure 95: BrakeAcc latency for Subject 11

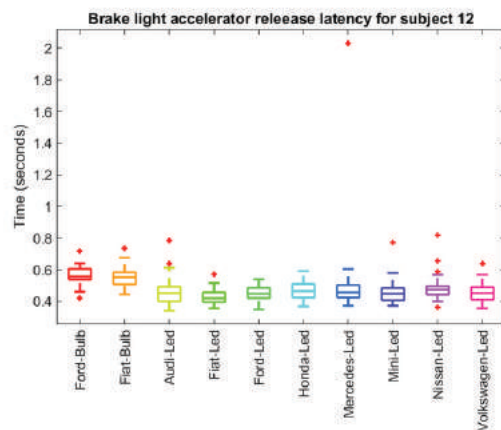

Figure 96: BrakeAcc latency for Subject 12

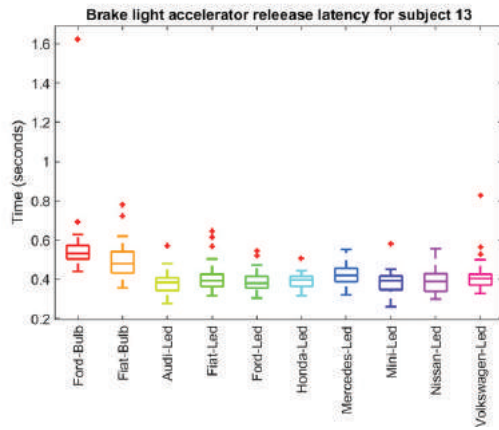

Figure 97: BrakeAcc latency for Subject 13

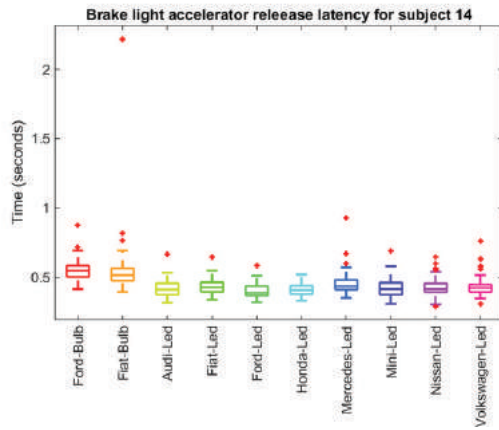

Figure 98: BrakeAcc latency for Subject 14

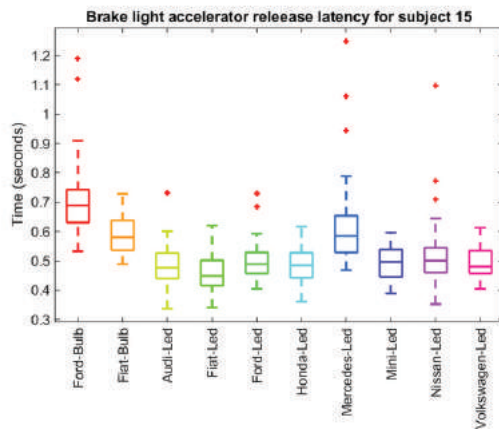

Figure 99: BrakeAcc latency for Subject 15

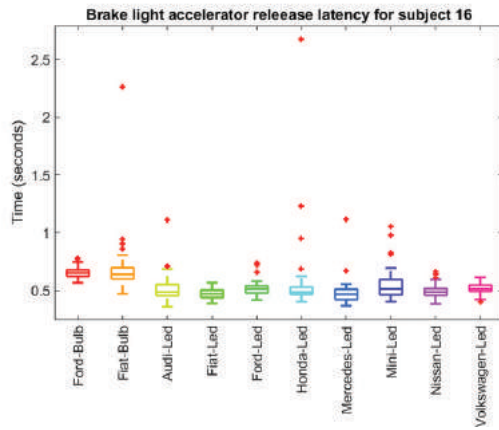

Figure 100: BrakeAcc latency for Subject 16

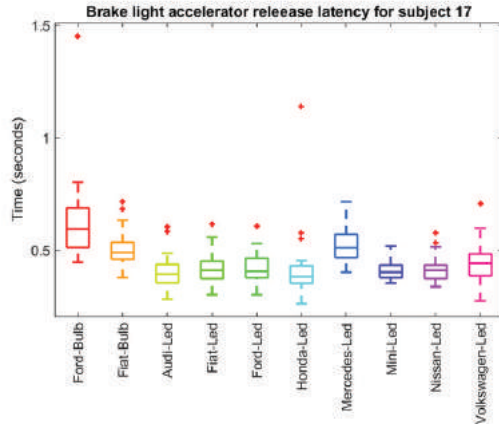

Figure 101: BrakeAcc latency for Subject 17

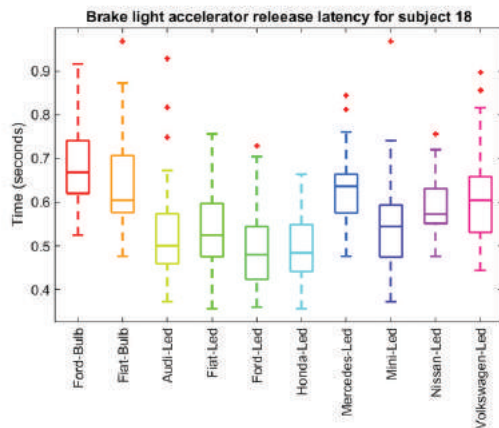

Figure 102: BrakeAcc latency for Subject 18

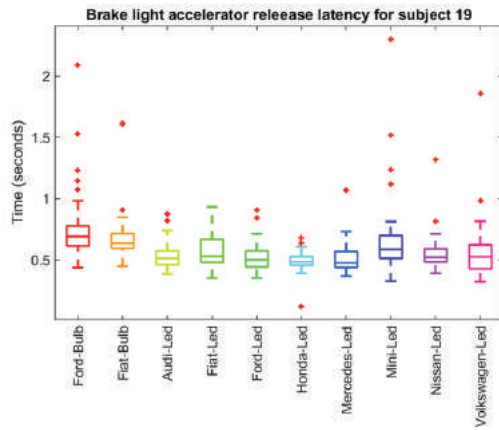

Figure 103: BrakeAcc latency for Subject 19

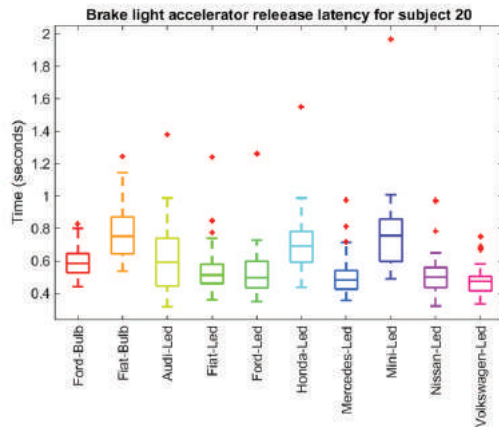

Figure 104: BrakeAcc latency for Subject 20

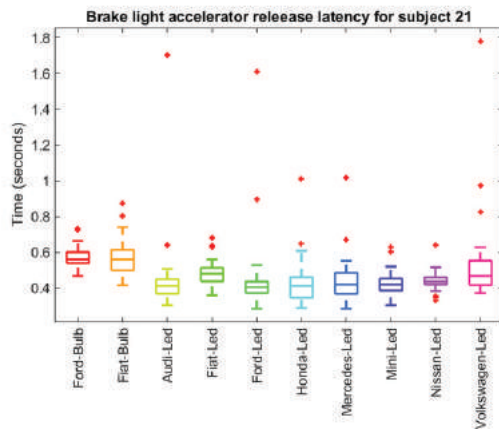

Figure 105: BrakeAcc latency for Subject 21

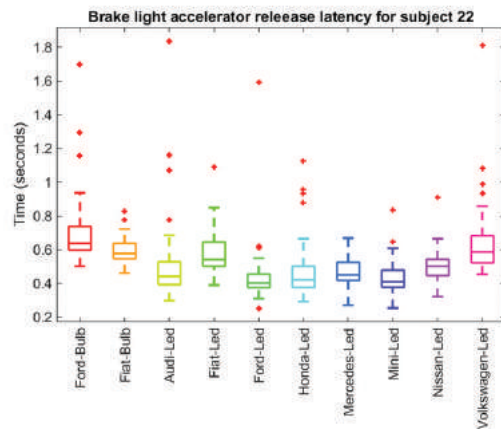

Figure 106: BrakeAcc latency for Subject 22

Appendix F - Accpdl (plots from all subjects)

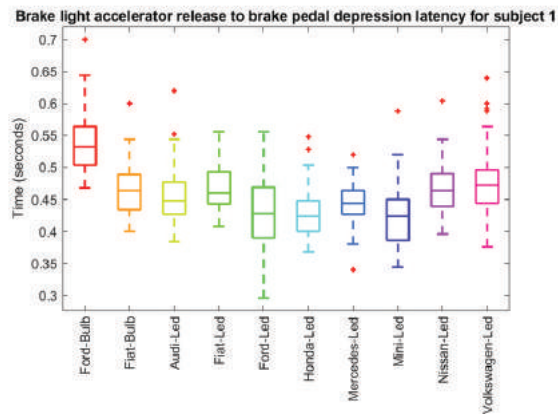

Figure 107: AccPdl latency for Subject 1

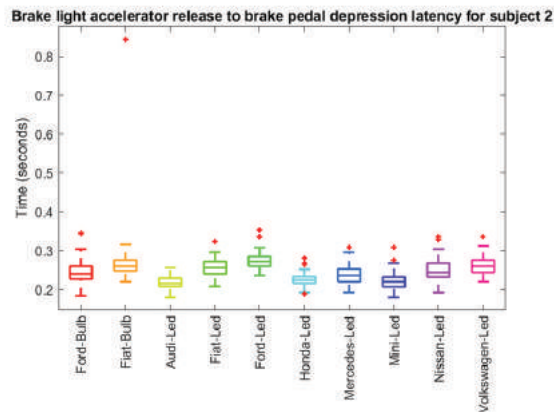

Figure 108: AccPdl latency for Subject 2

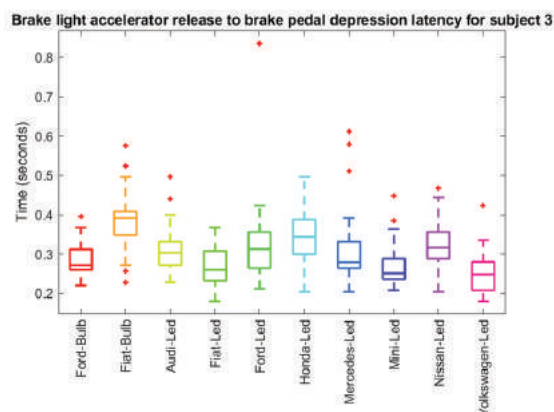

Figure 109: AccPdl latency for Subject 3

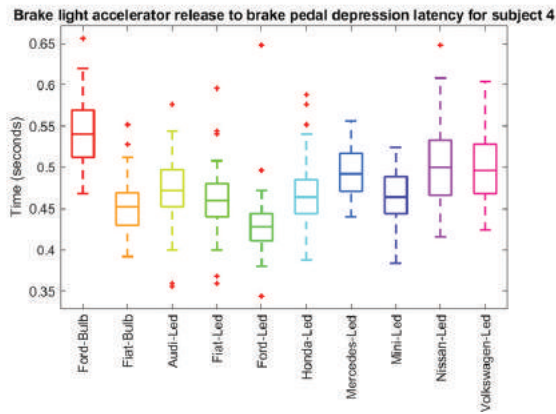

Figure 110: AccPd latency for Subject 4

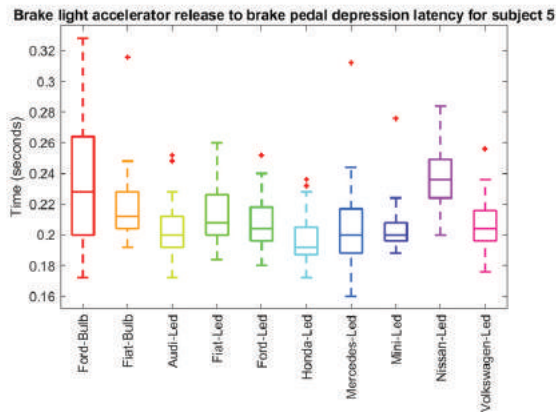

Figure 111: AccPd latency for Subject 5

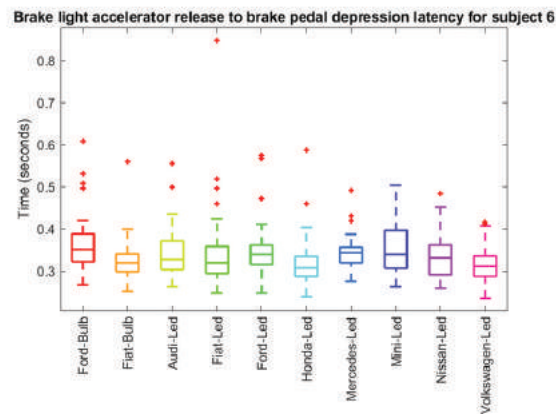

Figure 112: AccPd latency for Subject 6

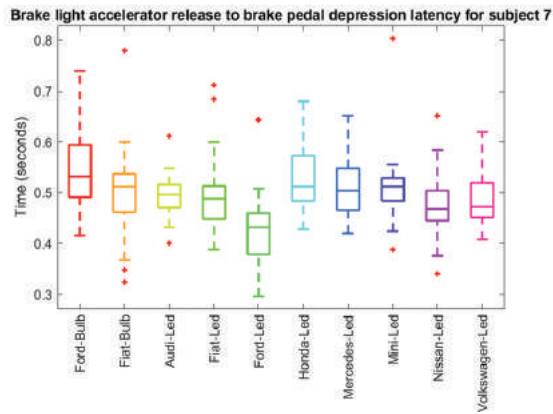

Figure 113: AccPdl latency for Subject 7

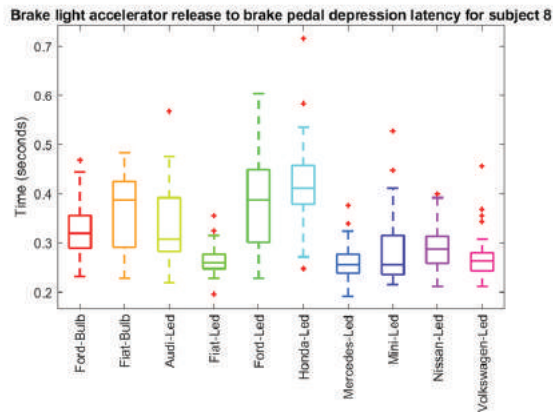

Figure 114: AccPdl latency for Subject 8

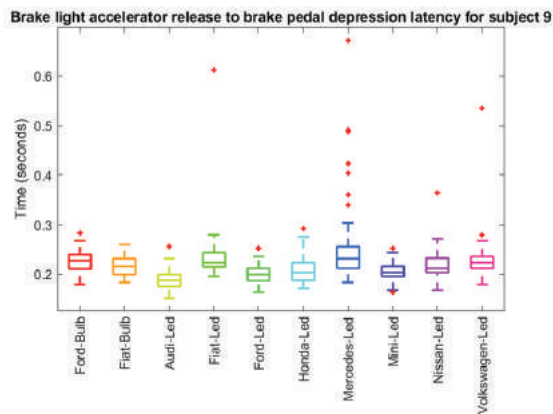

Figure 115: AccPdl latency for Subject 9

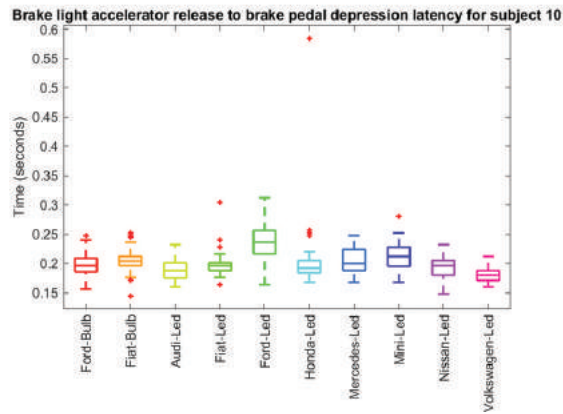

Figure 116: AccPdl latency for Subject 10

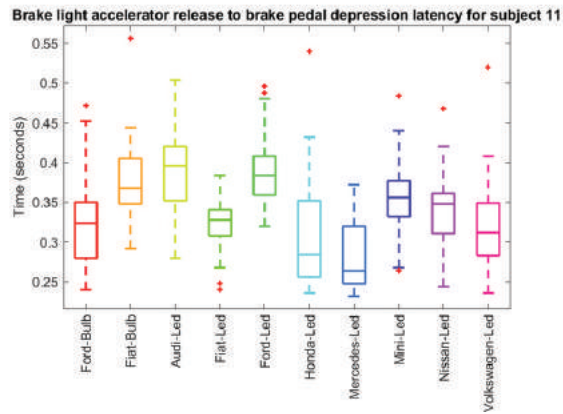

Figure 117: AccPdl latency for Subject 11

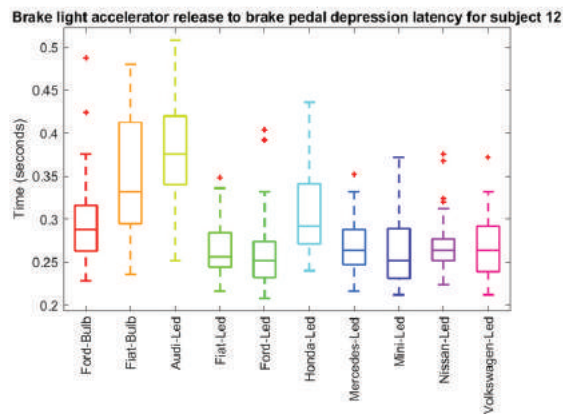

Figure 118: AccPdl latency for Subject 12

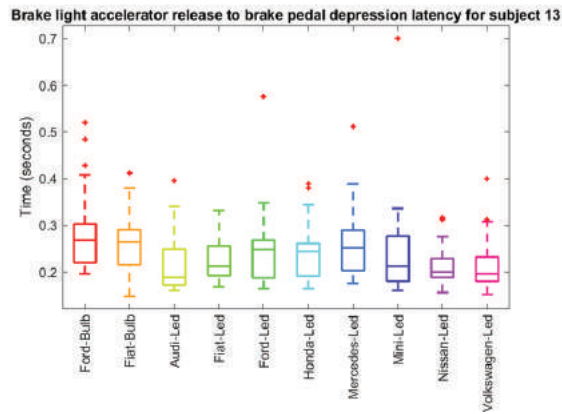

Figure 119: AccPdl latency for Subject 13

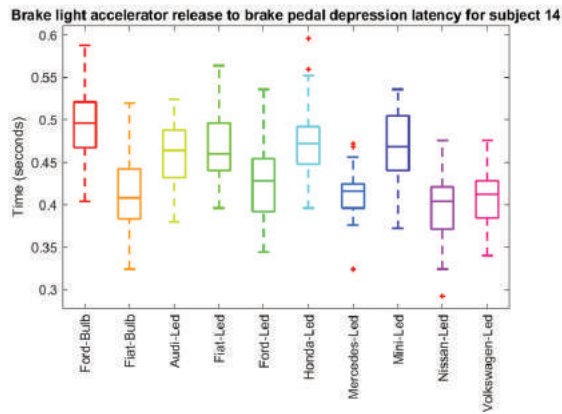

Figure 120: AccPdl latency for Subject 14

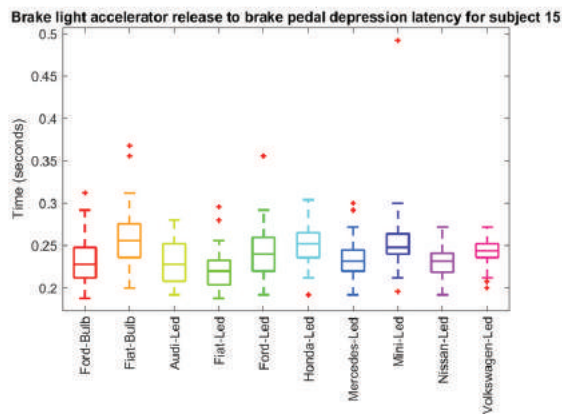

Figure 121: AccPdl latency for Subject 15

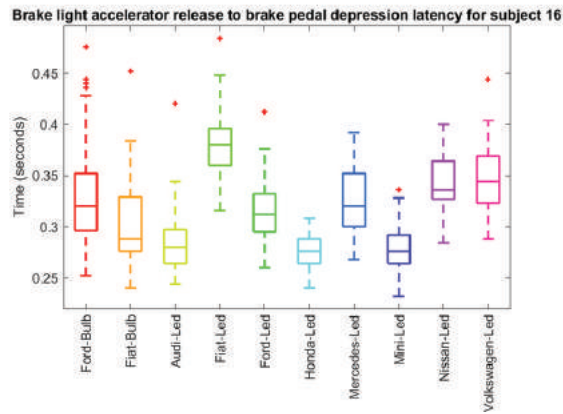

Figure 122: AccPdl latency for Subject 16

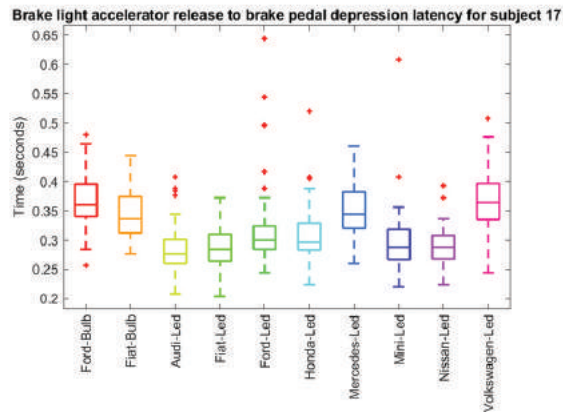

Figure 123: AccPdl latency for Subject 17

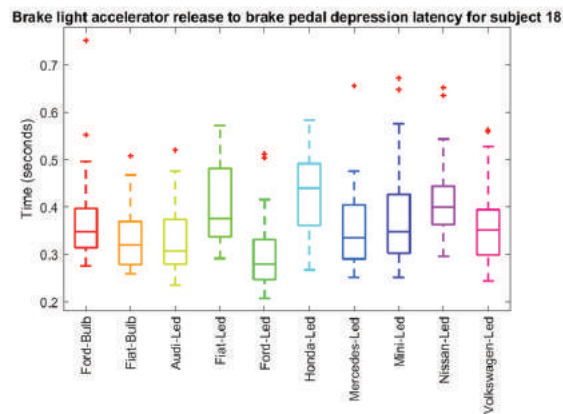

Figure 124: AccPdl latency for Subject 18

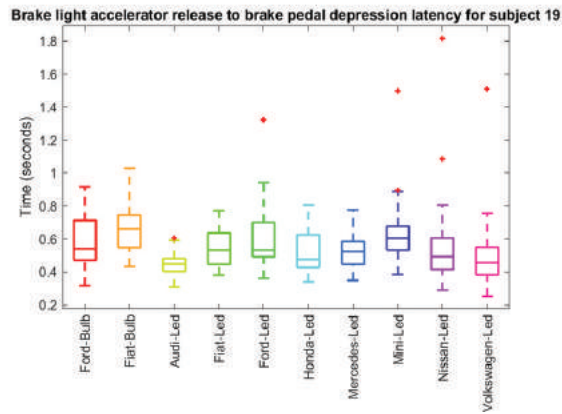

Figure 125: AccPdl latency for Subject 19

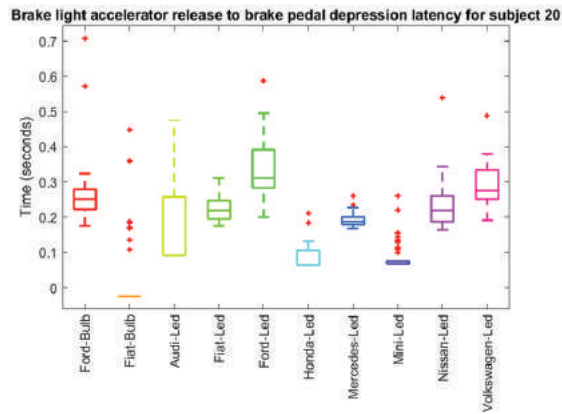

Figure 126: AccPdl latency for Subject 20

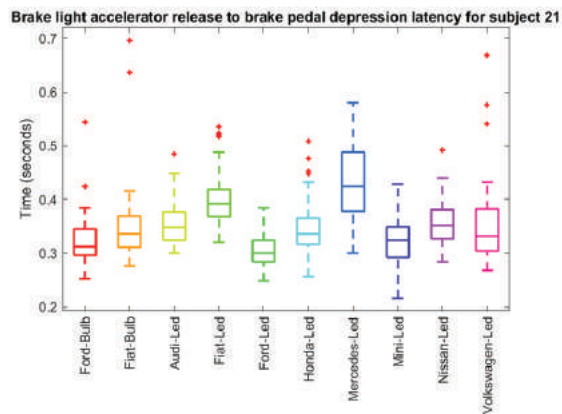

Figure 127: AccPdl latency for Subject 21

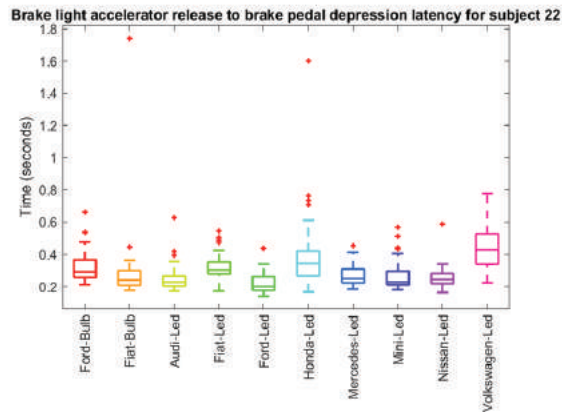

Figure 128: AccPdl latency for Subject 22

Appendix G - Experimental Driving Route for WP3

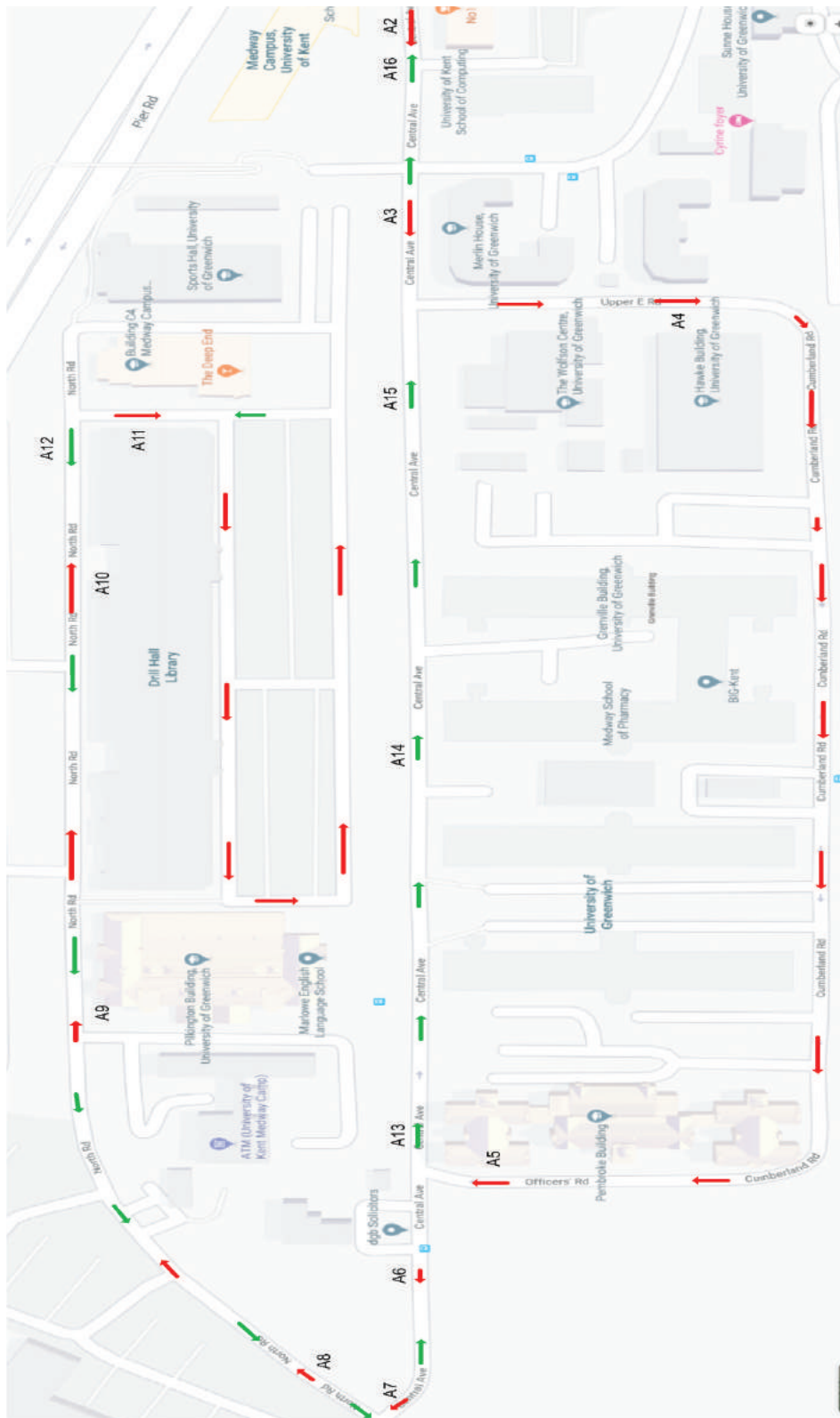

Figure 129: Driving Route