

TABLE OF CONTENTS

1. Cover Letter
 2. Fire Hazard Assessment
 3. Personal Comments & Suggestions
 4. Introduction
 5. Fire Behavior
 6. Fire Risk Evaluation
 7. Site Location
 - a. Topography
 - b. Driveways, Roads & Access
 8. Defensible Space
 9. Structure Design
 - a. Vents, Eaves & Soffits
 - b. Windows & Glass
 - c. Doors
 - d. Roofs
 - e. Decks
 - f. Walls & Siding
 - g. Fireplace Chimneys & Stovepipes
 - h. Other Design Considerations
 10. Plants for FireWise Landscaping
 - a. Flowers
 - b. Shrub
 - c. Large Trees
 11. Closing Comments
-
-

[REDACTED]
Lostine, Oregon 97857

[REDACTED]

I would like to thank you for allowing me to spend some time in evaluating your property. And it is my hope that the information that I provide to you in this report will help you to decide what recommendations work best for the way you choose to make your property as fire safe as possible. In this report I have provided a copy of my basic "Fire Hazard Structure Assessment Score Sheet". This score sheet gives you a score on how I rated your structure on the day I arrived. As you will see the lower the score the less Risk/Hazard I viewed your structure. Likewise the higher the score the more concerns I would have for your structure. I also have included with the score sheet my observations and recommendations. Please remember that my recommendations are given with the assumption that the property owner would do little or no work that may be recommended by ODF "Oregon Department of Forestry". With regards to vegetative fuel deductions within the 100 radius of your home. Thus, if you do incorporate recommendations of ODF you may be able to do less of my recommendations and still be able to have a relatively safe structure in the face of an oncoming wildfire. You will also find in this report a lot of additional information that I hope you find useful in preparing your property for wildfire. If you have any questions concerning this report or would like to discuss other options please feel free to contact me at any time. It is my goal to help all my neighbors to make their properties as fire safe as possible. And in turn assure that the beautiful Lostine Canyon will continue to be a GREAT place to live.

Gary L. Willis



Chairman
Fire Preparedness Committee

FIRE HAZARD ASSESSMENT /STRUCTURES

Building Construction:

A. Material (predominate)

- | | | |
|---|----|---------|
| 1. Noncombustible/ fire-resistant siding, eaves, and deck | 0 | _____ |
| 2. Noncombustible/ fire-resistant siding, eaves, and combustible deck | 10 | _____ ✓ |
| 3. Combustible siding, eaves and deck | 20 | _____ |

B. Screening

- | | | |
|---|----|---------|
| 1. All opening to the inside of the structure properly screened, (Eaves, foundations Vents, Etc.) | 0 | _____ |
| 2. Opening to the inside of the structure not properly screened | 10 | _____ ✓ |

Roof Material:

- | | | |
|--|----|---------|
| 1. Class "A" Roof (Metal, Composition/ Asphalt, Slate, Tile, Clay) | 0 | _____ ✓ |
| 2. Class "B" Roof (Pressure-Treated shingles & Shakes) | 5 | _____ |
| 3. Class "C" Roof (Plywood, Particle board, & wood shingles) | 20 | _____ |
| 4. NO Rating | 25 | _____ |

Placement of Gas and Electric Utilities: (Check all that apply)

- | | | |
|--|----|---------|
| 1. Both Underground | 0 | _____ ✓ |
| 2. One Underground & One Aboveground | 1 | _____ |
| 3. Both Aboveground | 5 | _____ |
| 4. Propane Tank less than 30 feet from structure | 10 | _____ |

Private Road Accessibility:

- | | | |
|--|----|---------|
| 1. Dead end road of 100 feet or less or loop driveway | 0 | _____ |
| 2. Dead end road of 150 feet or less/with turnarond | 5 | _____ |
| 3. Dead end road of greater than 200 feet but less than 500 Feet /with turnaround and pullout, | 10 | _____ |
| 4. Dead end road greater than 500 feet/ with turnaround and pullouts | 15 | _____ ✓ |
| 5 Dead end road greater than 500 feet with No turnarounds or pullouts | 25 | _____ |

Address and Road Signage:

- 1. Present & Readable 0
- 2. Not Present or Unreadable 5

Fire Protection Water Source:

- 1. Hydrant or other water source within 500 feet of the house 1
- 2. Hydrant or other water source within 750 feet of the house 5
- 3. Hydrant or other water source within 1000 feet of the house 10
- 4. Hydrant or other water source further than 1000 feet from house 15
- 5. Water source more than 20 minutes round trip from the house 25

Fire Station Location:

- 1. Fire Station less than (5) five miles from structure 1
- 2. Fire Station more than (5) five miles from Structure 5

Fixed Fire Protection:

- 1. NFPA Sprinkler System or Home Hose System 0
- 2. None 5

Primary Fuel Break Area/ Defensible Space:

- 1. 30-50 feet around structure/ free of all material that would be flammable 0
- 2. 30-50 feet around structure / free of all material that would produce
Flame length of over (1) one foot. 10
- 3. 30-50 feet around structure contains various material that if ignited would cause
Flame length of over (1) one foot. 20
- 4. No effort made to develop 30-50 foot Defensible space around structure. 30

NAME: _____

ADDRESS: _____

CITY/STATE: LOSTINE, OREGON

DATE OF ASSESSMENT: 2/11/18

TOTAL SCORE: 55

HAZARD ASSESSMENT

TOTAL POINTS

Low Hazard	>40
Moderate Hazard	40-60
High Hazard	60-90
Extreme Hazard	<90

SCORE IS BASED ON LOG HOME ONLY

COMMENTS / SUGGESTIONS

1. Though log structures can and will burn the large diameter logs tend to be quite fire resistant and unless you have heavy fire contact directly onto the logs for several minutes they usually will not catch fire. However EXTREME care should be taken when applying preservatives to your logs during normal summer maintenance as many products are very flammable. And having your logs exposed to a wildfire within weeks of one of these preservatives being applied to your home would be problematic.

2. One major concern I seen while at your home is the soffits need to be enclosed and properly vented and screened as soon as possible to keep potential sparks from a wildfire from entering your home and attic space. (Please refer to page 15 of the supporting material provided for further information)

3. I found all windows to be at least double pane and this is good. However I would suggest checking the caulking around windows for areas where sparks can settle and smolder into a fire. Pay attention to windows on the East, North, and West sides of your home. (Also please refer to page 16-18 of supporting material provided for further information)

4. Make sure all foundation vents are screened properly preferably down to 1/8 inch and that winter covers are in tack and are able to be closed in case of a summer wildfire.

5. The roof is metal and this is GREAT. If you have any exposed screws have them checked at least every two years to make sure they have not loosen up as this can add to areas sparks can enter. Also if roof edge is not enclosed sparks can blow in under the metal roof. You can install a wood piece that closes off the gap and sparks cannot get in.

6. All decks were made of wood thus care should be done to close in around the bottom edge of the decks so animals and birds don't deposit flammable material under the deck that sparks can ignite. Also on eastside deck I suggest you caulk between the deck and the wall of your home. Simply adding a little gravel on the south and west corners of the other deck is all that would be needed.(Refer to pages 22-23 of supporting information for further help in this area)

7. Check Dryer vent to assure it is operating properly as to not allow sparks through a malfunctioning flipper vent. Sparks into dryer lint is a great place for a fire to get started.

8. Also remember wood patio furniture is a prime starter of home fires especially in the face of a wildfire. Consider replacing it or have a plan to move it to a safe place before you evacuate your home.

9. Your storage shed northwest of the house has T-1-11 siding thus it is flammable. In order to protect this structure more, I suggest trimming ladder fuels as high as possible. Clean all flammable material from around the perimeter . And add some more gravel around the building to about 10 feet. This structure would also benefit by the elimination of a couple of trees, but that is a ODF topic.

10. Your other woodshed that is southeast of the house is a nondefendable structure. And it is far enough away from your home that even if it was to catch fire during a wildfire event the home should not be threatened.

11. And finally your driveway has some concerns for me. It is a long driveway at 850 feet. Depending on wildfire activity in the area, a fire taskforce leader may or may not put a crew at your home. The problem is, a crew could get trapped in there by a spot fire and not be able to get out. Your turnout just below your home is good but it needs to be brushed back and a little gravel applied. The turnout about 250-300 feet below that on the first curve is good. But I would suggest brushing it back as well to allow a radius of 30-40 feet and put in baserock and gravel. Your road width is at around 15 feet which is ok if I could get 20 feet that would be better, but I understand the limitations in the area. It's just a little tight for large fire trucks but it can be done especially with the improvements to the turnouts. It would also help if the fire department ever needed to do tandem pumping up your driveway. Make sure the overhead clearance is kept at 14 feet or better. (Please refer to page 7 of the included information for further guidance). The suggestions I have made here are not only for wildfire access but also to help get larger firetrucks to your home in case of a structure fire or medical emergency. I would like to see all residents consider putting in large address numbers that reflect at night. This will help find you in the dark. { If we can't find you we can't help you }.

12. I believe you have done a very good job in preparing your property for the day wildfire strikes our community. But because of your location I strongly suggest that you go above and beyond to self prepare your property the best you can. Knowing what I know, if fire is really bad in the Lostine Canyon. I don't know any taskforce leader that would put a crew up a long driveway with only one way out. If they got here quick enough they would at least go up and triage your home and do what they could and then leave. But if you have already done things properly you will be far better off. Remember even in best of conditions when wildfire hits we will be basically on our own for the first 24-48 hours. And if we have done our jobs ahead of time we can use that time to safely get our loved ones out of harms way.

13. The rest of this report will be information I have gathered together to hopefully help you prepare your home and property for the wildfire event. If you need anything else please let me know.

INTRODUCTION

What I would like to do now is offer some strategies that I believe can minimize property losses from wildland fires in the Lostine Canyon. This information is intended for our neighbors in the Lostine Canyon or anyone considering building or modifying any structure in a Wildland-Urban Interface environment. A Wildland-Urban Interface (W-UI) area is a geographical area where structures and other human development meets or intermingles with wildland or vegetation fuels. Basically, W-UI is any area or location where fire involving wildland fuels (trees, shrubs, vegetation) can potentially ignite combustible homes and structures.

When the hot dry south winds blow down the Lostine Canyon lead to an afternoon thunderstorm and lightning strike don't expect a fire engine to park in front of your home to protect your family and possessions. There just aren't enough firefighting resources to protect every home in the canyon. In a matter of minutes a wildfire can jump from a burning hillside, race through our neighborhood and destroy your home and property.

Instead of all fire protection responsibilities residing with fire agencies in Wallowa county, homeowners must take responsibility for assuring FireWise conditions and the initial fire defense of their residences/property before and during wildland fires. Wallowa County Fire agencies are a community partner that provides information, coordinates and assists in meeting FireWise requirements, and provides fire suppression assistance in the event of a fire.

The problem is the suppression of wildland fires and other mitigation efforts have greatly reduced the occurrence of fires and subsequent destruction of vegetation and property. But on the other side are the problems of increased population in the W-UI areas, the increased number of structures and increased density of vegetation for fuel. One might argue that preventing wildfires would prevent W-UI fire destruction. But we know that wildland fire is historically a naturally occurring process that the forest depends on to maintain good health. By suppressing fires to protect our homes we have interfered with the process. Wildland fires will always occur in the Lostine Canyon and thus will have an impact on people, property and resources. We may have some choice of when and where we have wildland fires, but we do not have the choice of not having wildland fires. W-UI fire-loss mitigation should concentrate on the residence and its immediate surroundings rather than attempting the elimination of wildland fire encroachment.

The following information that I have collected for you to use offers measures for reducing the fire risk , recognizing that you can "trade-off" various design features of your homes exterior and its surroundings to meet FireWise requirements, depending on the property owners goals for their property. Leaving the surrounding area in its natural state can mean that the structure needs to be nearly fireproof, usually much too expensive to build. And even if you have already built, Creating a surrounding defensible space large enough to protect a typical combustible structure may not be practical or desirable. Choosing the best combination of these two strategies for a particular site will provide a more comprehensive solution to your desired outcome.

I would like you to consider a two part approach to solving this problem:

1. Reduce the Hazards of Forest fuel loads on your property.
2. Build structures that are more fire resistant.

I am not suggesting any one or all of the applications that I have have discussed here are absolutely necessary. Rather I offer them to give you a better understanding of how structures in the wildland interface ignite during a wildland fire so you can make a better choice for yourself. It is my sincere hope that the information you are about to read will make you more FireWise.

Gay
?

FIRE BEHAVIOR

WILDFIRE DOES NOT DISCRIMINATE!

Research shows that a FIREWISE prepared house with a surrounding FIREWISE zone is 85% more likely to survive a wildfire than one that is not prepared.

Understanding fire behavior, especially how hot a fire will be and how long it will be at the building site, will help homeowners and builders decide how *defensible* a house needs to be, and what actions need to be taken to make the building site more fire-resistant.

Three primary factors always affect wildland fire behavior:

1. FUEL

The type and density of the surrounding vegetation provides the fuel to keep the fire burning. Not all plants and trees burn the same way. Some almost never burn, some burn at different times of the year, and others can burn almost anytime. A wildland fire considers homes and structures as just more fuel.

2. TOPOGRAPHY

The fire is affected by the steepness of slopes, valleys, saddles, ridges, and other land features in and around the building site. Natural vegetation varies widely between the extremes of south facing and north facing slopes.

3. WEATHER

Wind, temperature and humidity conditions affect each fire, and is highly variable in terms of time and location. Extended periods of low moisture increase the possibility of wildfire. Low humidity and high winds increase and intensify fire behavior, and wildland fires will often create their own internal weather conditions.

We have never been able to control the *weather* factor. But we *can* modify or accommodate *topographical features*, we certainly *can* control the existing *vegetation (fuel)* on and around the property, and we *can* build or modify *structures* to minimize their potential for ignition.

Remember . . .
most houses
are just trees in
another form!



Fires do not spread by flowing over the landscape, and high intensity fires do not engulf objects like avalanches and tsunamis. All fires spread by meeting the requirements for combustion—that is, a sufficiency of fuel, heat, and oxygen.

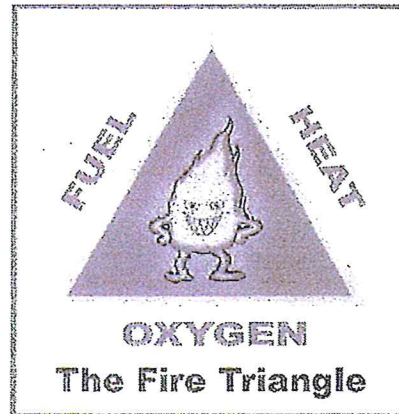

The fire triangle—fuel, heat, and oxygen represents the critical factors for combustion. Fires burn and ignitions occur only if a sufficient supply of each factor is present.

In the context of **severe** wildland-urban fires, oxygen is not a limiting factor, so this type of fire spreads according to a sufficiency of fuel and heat. Homes and vegetation are the fuel, and the heat comes from the flames and/or firebrands (airborne burning embers) from the surrounding fires.

Wildland-urban fire becomes a problem when a fire burning in wildland vegetation fuel gets close enough with its flames and/or firebrands to potentially create ignition of *residential fuels* (homes & structures). Reducing home & structure losses due to wildland fire then involves mitigating the fuel and heat components sufficiently to prevent ignitions.

Vegetation management, on the other hand, cannot be extensive enough, in a practical sense, to significantly reduce firebrand ignitions. Therefore, the structure and its immediate surroundings should be the focus for activities intended for improving structure ignition risk.

MECHANICS OF HEAT TRANSFER FROM FIRE

Structure Ignition:

In order to improve structure survivability we need to understand how fire ignites buildings, fire behavior, how hot it will be, and how long it will be at a building site. This will help us decide how fire resistive a structure needs to be so we can make better choices in our building techniques to maximize the structure's ignition resistance.

Four principal factors are responsible for structure ignitions:

- * Indirect heating by convection
- * Firebrands (airborne burning embers)
- * Indirect heating by radiation
- * Direct flame contact or impingement

Convection:

As a fire burns it releases hot gasses that rise, from the combustion of vegetation and structures, causing strong horizontal wind and strong vertical air currents as air rushes in to replace the rising air.

The vertical air currents also carry partially burned materials, *firebrands*, into the air and carry them horizontally long distances from the fire. Once out of the rising air currents, the firebrands fall back to the ground onto horizontal surfaces such as roofs, decks, and dry vegetation around the structure.

The same superheated convective air dries and heats all fuels ahead of the fire, making any combustible materials ready to ignite when the fire gets closer.

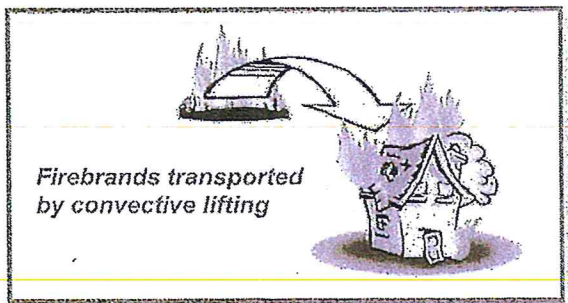

Radiation:

The fire also creates large amounts of radiant heat, similar to heating from the sun. Radiant heat transfers on a straight line and its effect can be reduced by barriers. Radiant heat sources also dry and heat the vegetation and structures in the fire's path, making them more easily ignited when the flames come in contact.

Vertical surfaces like wood siding can ignite from this effect well before the fire actually reaches the structure.

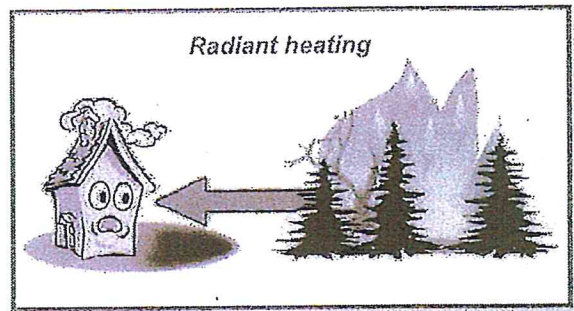

Direct Flame Contact:

Continuous and abundant vegetation, like those found in un-managed natural areas, provide a direct path for a fire to contact a structure. Creating a defensible space and fuel breaks around a structure is intended to reduce this exposure.

External sources of burning materials, excluding firebrands, and the site characteristics influence the amount of heat transferred to the structure. For example, burning trees, shrubs, and wood piles at various distances from the structure determine how much the exterior is heated. When there is burning material down-slope from the structure, the intensity of convective heating is increased.

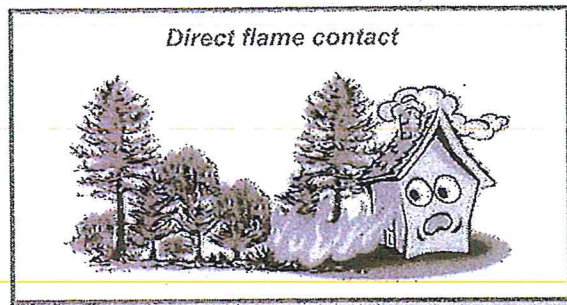

FIRE RISK EVALUATION

You can begin to determine the fire exposure risk to your structure with this short evaluation, based on the "Wildland Home Fire Risk Meter" developed by the National Wildfire Coordinating Group.

First, evaluate the vegetation for at least 100' from the structure

Vegetation	Score
* Open water, bare rock, watered lawn, cultivated field, etc.	0
* Continuous grass, weeds, shrubs less than 2', few trees, (very open).	1
* Evergreen (conifer) or hardwood (maple, oak, hickory) forest, with many tops touching (closed), with only leaf or needle litter, but no vegetation that allows fire to spread from lower vegetation to the tree tops (ladder fuels).	1
* Grasses/shrubs/young evergreen trees/dead branchwood 2-4 feet; open forest, very few tree tops touching.	2
* Dense young green shrubs with no dead branchwood.	2
* Medium dense evergreen forest having some tree tops touching, lower vegetation comprised of live and dead herbaceous with patches of young evergreens.	3
* Medium dense shrubs 2-6' tall, tree density varies from open to many trees touching.	3
* Dense evergreen forest having many tree tops touching with lower vegetation that will carry fire into the tree tops.	4
* Thick, tall grass over 3'.	4
* Dense mature shrubs 6 or more feet tall with dead branchwood.	4

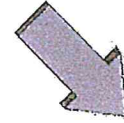

Then, measure the Slope of your site

Slope	Score
Level	0
0° - 10°	1
10° - 20°	2
20° - 30°	3
30° +	4

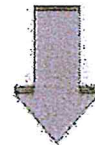

Finally, Add the Slope and Vegetation Scores to get the Hazard Rating

Scores	Hazard Rating
0	0
1 - 2	low
3 - 4	medium
5 - 6	high
7 - 8	very high

FIRE RISK EVALUATION

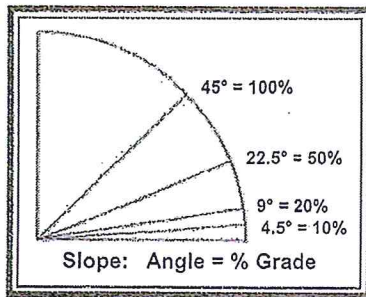

Slope is the angle of the ground relative to the horizon, and is measured in either degrees or as a percent. Slope topography shows the steepness of the slope and the shape of the land. The steeper the slope, the more quickly a fire moves, and the hotter it burns. For example, a fire will spread twice as fast on a 30% slope than it will on level ground. So, owners of structures located on steep slopes will need to consider more fire resistance protection.

The National Fire Protection Agency (NFPA) also published a detailed "Hazard Assessment Form" in the NFPA 1144 Standard for Protection of Life and Property from Wildfire, 2002 Edition. (See page 30). Another evaluation tool is published in the 2003 International Urban-Wildland Interface Code, Appendix C, "Fire Hazard Severity Form" (see page 28).

TOPOGRAPHY AND ITS EFFECT ON FIRE BEHAVIOR

Site Suitability:

The location or site of a structure will influence the intensity and duration of the fire to which it is exposed. The surrounding topography and vegetation characteristics directly affect how a fire will react and burn. When choosing a suitable site for a new home, (or renovating, or adding to an existing structure) be sure to consider the slope of the terrain.

Build on the most level portion of the property because the fire path is less predictable on sloping sites. Fire spreads rapidly and with more intensity up slopes, even minor slopes. The direction of a fire on a flat site is somewhat unpredictable, but will usually be determined by the prevailing winds.

Aspect:

Aspect is the direction the *slope faces*. Natural vegetation varies widely between the extremes of south facing and north facing slopes.

South facing slopes have the least vegetation because they dry out faster and have less available moisture. Because of their dryness and temperature, south slopes are most likely to ignite and burn.

East and West slopes generally have more vegetation than south slopes. They are more prone to drying out in the summer, so the fire potential increases during summer months.

North slopes typically have the most dense vegetation and higher moisture content. Fires occur there less frequently, but when they do they burn with more intensity because there is so much more fuel.

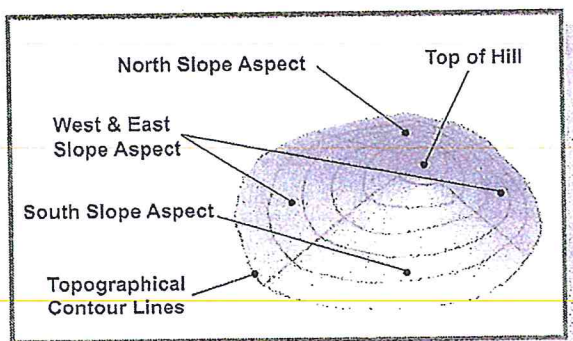

Aspect Ratio:

Aspect Ratio is the ratio of the structure dimensions between the geographical north-south axis and the east-west axis. In our climate it is generally better if the structure is longer on the east-west axis. The structure then presents its widest side to the winter sun and its narrowest side to the probable fire path. In our area prevailing winds and the fire path are typically from the southwest. This ratio also provides a more favorable energy relationship with the climate, and the benefits of passive solar heat from the sun.

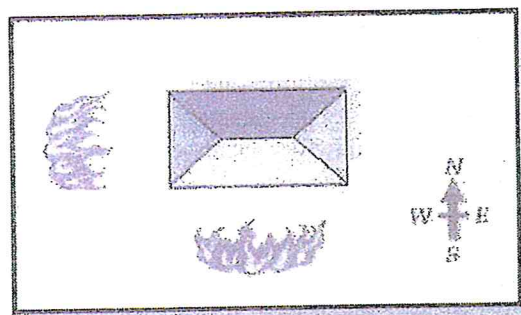

However, if a structure presents its widest exterior to the direction from which a fire is likely to come, it will be more vulnerable and more fire resistive materials will be needed on that side.

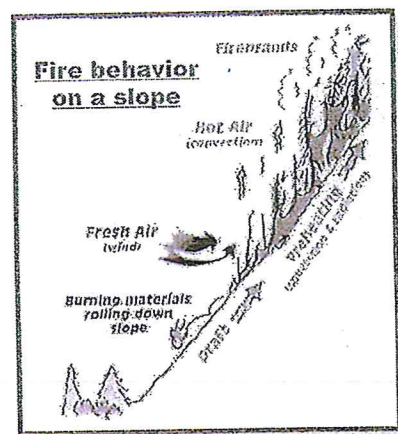

A new home should be located (set back) at least 30 feet from the edge of any ridge, cliff or top of a slope to avoid the problem of a fire moving up the ridge or cliff and prevent the exposed structure from being hit directly by flames and heat traveling up the hill. For homes higher than one story, increase the distance from the edge of the cliff.

SITE LOCATION

DANGEROUS TOPOGRAPHIC AREAS OF HIGHER FIRE BEHAVIOR

Some topographic features can be dangerous areas in which to build structures. Steep slopes, canyons and valleys will channel a fire like a “chimney”, and increase its intensity and rate of spread. A level site is much safer and easier to manage than a sloped site.

When a valley crosses a ridge it creates a *saddle* between the higher parts of the ridge. Like a valley, saddles will channel, intensify and speed-up fire behavior. Saddles tend to be common structure sites because they offer some shelter and flat areas. It is important to recognize that saddles are natural fire paths where fire will travel first and with more intensity.

A *valley* is a concave form and tends to collect and concentrate wind. As a wildland fire moves through such an area, its intensity increases. If the valley is narrow with steep sides, like a *canyon*, this “chimney” effect is even more intense.

Ridges experience more wind because they are elevated above the surrounding land. When a fire moves up a slope toward a ridge, it gathers speed and intensity. As the wind crosses a ridge it rolls around exposing all sides of the structure to wind and fire. There are usually no flat or protected areas on ridges.

Natural barriers and buffer zones are created by existing topographical features, and can actually reduce fire behavior and provide increased protection to the structure. Some examples of these features and barriers are natural rock outcroppings, wetlands, streams, lakes or ponds, and aspen groves or other naturally fire resistive vegetation. If possible, locate the structure to take advantage of these features so that the natural barrier is between the structure and the anticipated path of a wildland fire.

Of course many other factors such as privacy, views, access, and aesthetic values will affect your decision about structure location. Fire is just one of those factors. How high the fire hazard is, will determine whether fire is your primary consideration. The site’s physical features will determine the probable fire intensity, and dictate what combination of site modifications and building materials is necessary to compensate for the anticipated fire hazard. Existing structures should increase their **DEFENSIBLE SPACE** to compensate for nearby ridges, canyons, slopes and saddles.

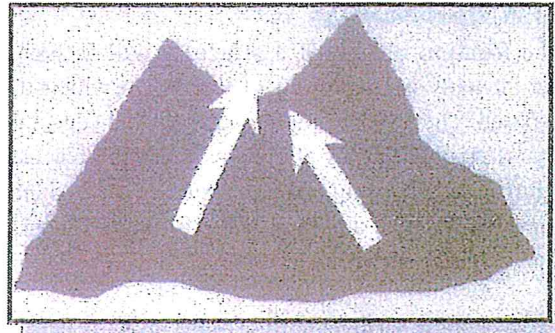

Saddle, low area on ridge

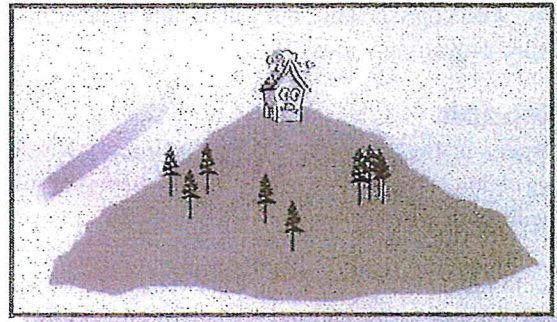

Ridge, with wind exposure

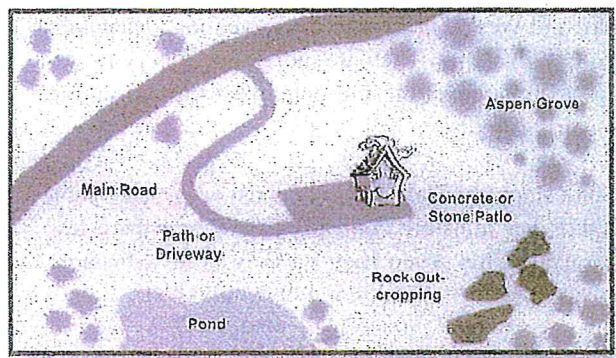

House location relative to natural fire barriers

SITE LOCATION

DRIVEWAYS, ROADS & ACCESS

We can follow all the guidelines and recommendations for site location and fire resistive building materials, but in the event of a wildland fire, *we also need to ensure that firefighters can find our home, they have access to defend it, and that we can safely evacuate the location if necessary.*

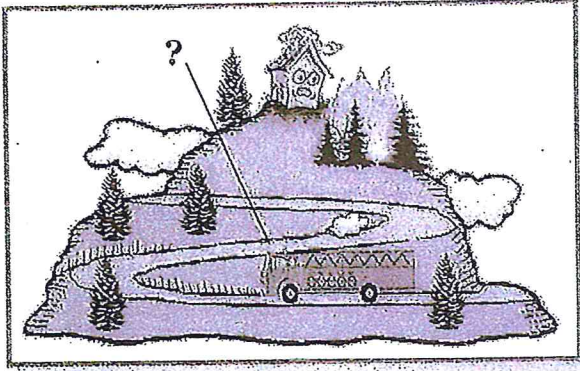

Keep your driveway as short as possible, and a minimum of 12-14 feet wide. If your driveway is 150 feet long or longer, provide a 45 foot turnaround or loop road, and a turn-out somewhere near the middle. Make sure any road leading to your house allows two-way traffic, is not too steep, and does not have curves that are too sharp to accommodate fire trucks. Ideally, your home site will have two routes of entrance and exit, for your safety and the safety of firefighters.

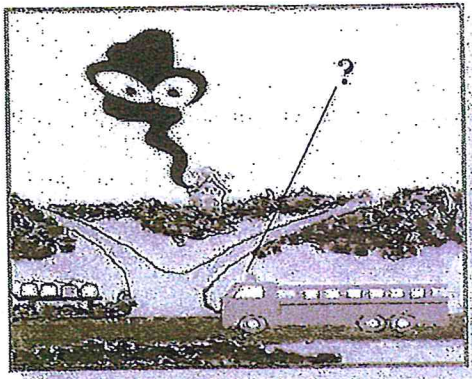

Access roads and driveways should be a minimum of 20 feet wide, with a slope of less than 12%. Clear vegetation back from the road and driveway at least 15 feet. Branches that overhang the access road or driveway should be pruned-up to 14 feet vertical clearance. Check power or telephone lines that run near or over driveways or access roads and ensure there is at least 15 feet minimum clearance to drive fire trucks underneath. If not, contact your utility company.

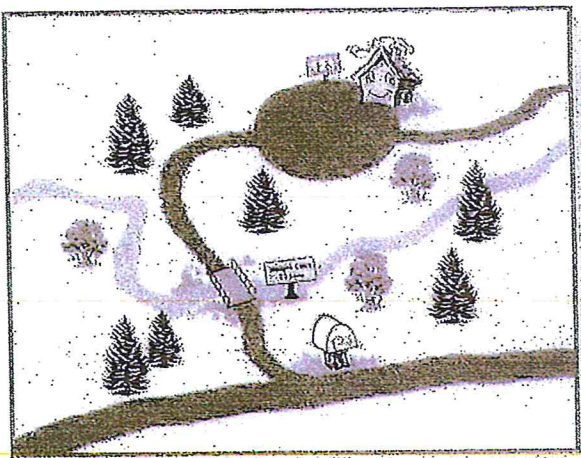

Bridges should be strong enough to support a fire truck weighing about 18 tons. If not, post the weight limit on both ends of the bridge. If you lock your entrance gate, leave a key with your local fire department.

Address numbers should be 4 inches tall, in reflective numerals, visible and legible from a moving vehicle on the roadway, day or night. If the house cannot be seen from the road, the address should be at the driveway entrance or on the mailbox. The home itself should have the address prominently displayed in large numbers which contrast with the house colors.

DEFENSIBLE SPACE

CREATING DEFENSIBLE SPACE

The most important person in protecting your home & structures from wildfire is not the firefighter: it is the property owner and the action the property owner takes before there is a fire.

Once you have evaluated the fire hazard rating of your site, and have taken advantage of the natural barriers available, you need to develop a plan to manage the surrounding area and forest. In other words, *create your defensible space*.

Defensible Space is usually defined as the first 30 foot area around the structure (Zone 1), if the property is flat. Depending on the *slope* of the property that area could increase up to 200 feet or more, because wildfires will travel much faster upslope.

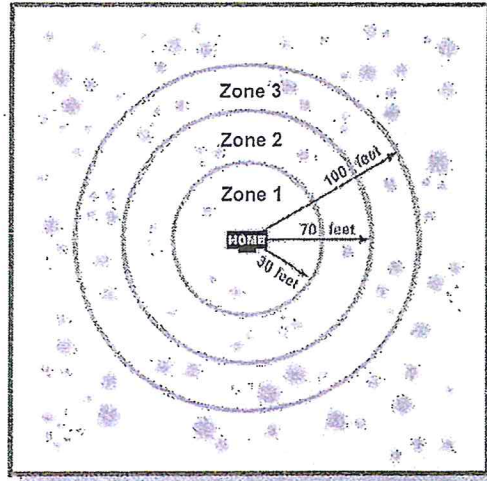

One of the key elements a fire needs is *fuel*. On your property, that *fuel* is the vegetation around your home. But, *Effective Defensible Space* doesn't mean *bare ground*. The following tips, and those on the next page, can create an attractive, well vegetated, yet *defensible* area around your home. This space should be designed taking into consideration the slope, aspect, the kinds of fuel, and the density of the fuels.

- ✦ Clean the area of dead trees, fallen branches, twigs, leaves, dead shrubs and trash.
- ✦ Replace native plants with ornamental landscaping plants or shrubs that are fire resistant. Space shrubs 15 feet apart and no higher than 18 inches.
- ✦ Stack firewood and scrap woodpiles 30 feet from, and uphill from any structure.
- ✦ Consider providing an emergency water supply of 1,500 to 10,000 gallons, with a gasoline powered pump in case electrical power is lost.
- ✦ If your water supply is a well, consider a gasoline powered electrical generator for the well pump in the event of power failure.
- ✦ Cut grass to a maximum of 3" and keep well watered.
- ✦ Clear a 10 foot area around LPG tanks and gas barbecue grills. Locate propane tanks 50 feet from structures, and on the same level with, or down-hill from structures.
- ✦ Driveways and access roads should be 12-14 feet wide. Keep clear, and trim overhanging branches up 14 feet.

DEFENSIBLE SPACE

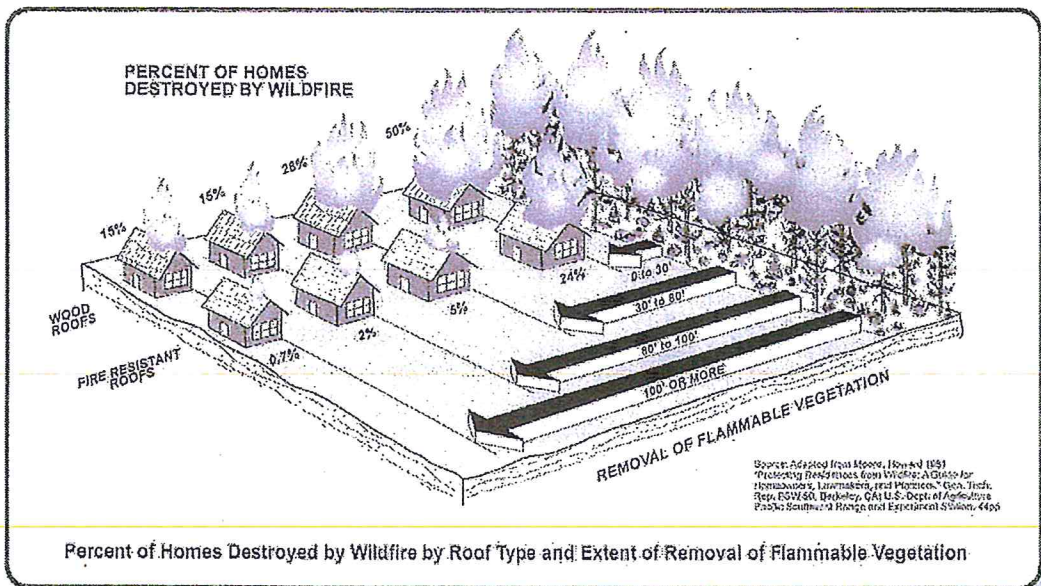

Percent of Homes Destroyed by Wildfire by Roof Type and Extent of Removal of Flammable Vegetation

DEFENSIBLE SPACE

DEFENSIBLE SPACE is the *Zone 1* area between a structure and an oncoming wildfire, where the vegetation should be modified to reduce the threat, slow down and cool the approaching fire, and provide an opportunity and space for firefighters to effectively defend the structure. The next 70 to 100 feet, *Zone 2 & Zone 3*, around the structure should also be examined for mitigation opportunities.

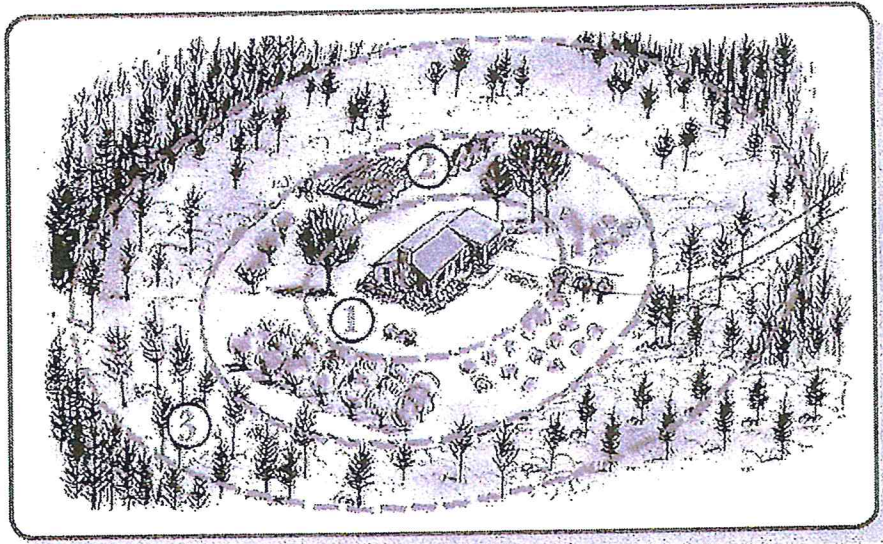

Zone 1: "Defensible Space"

This is the most important 30' space around your home. It is your yard and should be landscaped for leisure and fun, but at the same time as a potential barrier to the spread of fire.

- ◆ A good place for grass lawn and stone or concrete patios.
- ◆ Ornamental shrubs should be fire resistant and no taller than 18".
- ◆ Use fire resistant broadleaf trees for shade. Isolate trees.
- ◆ Prune lower limbs up to 10' above ground level.
- ◆ Eliminate foundation conifers such as junipers.
- ◆ Avoid using bark or wood chips for landscaping in this area.
- ◆ Crown spacing between trees should be at least 10'.

Zone 2: The Mid Zone

The next 40' (from 30'-70') space around your home. This is an area for landscape trees and shrubs, orchards and gardens, but not for wild, dense woodland vegetation.

- ◆ Maintain space between ornamental or wild shrubs at least twice as wide as their diameter.
- ◆ Prune lower limbs of trees up to 10' above ground level.
- ◆ Ideally, use only fire resistant trees and shrubs in this zone.
- ◆ Clean-up dead limbs and remove ladder fuels (see page 10).
- ◆ Cut or mow grass to a maximum of 8" high.
- ◆ Crown spacing between trees should not be less than 8'.

Zone 3: The Outermost Zone

The next 30' (from 70'-100') space around your home. This is the wild forest area, but precautions are still in order.

- ◆ Thin forest trees so that crowns are separated by at least 6-8'.
- ◆ Prune lower limbs of trees up to at least 6'-10' above ground level.
- ◆ Prevent ladder fuel from developing.
- ◆ Occasionally dead trees for wildlife are important, but accumulations of dead woody material on the ground, high or dense slash, or patches of dead trees should be kept to a minimum or eliminated.
- ◆ Clean-up dead limbs and remove ladder fuels.

During a wildland-urban fire, a home ignites from two possible sources: directly from flames (radiation and convection heating) and/or from firebrands accumulating directly on the structure. Reducing home ignition potential then suggests a twofold management approach:

1. Vegetation management - create Defensible Space around the structure to limit the amount of heat the structure will be exposed to, and to limit the time the structure is exposed to heat.
2. Application of Firewise structure design and use of fire resistant construction materials.

DEFENSIBLE SPACE

Firewise thinning and pruning can help your home survive a wildfire.

Managing the *crown spacing* between trees, *pruning* up limbs, and eliminating *ladder fuels* will keep a wildland fire on the ground. A fire on the ground is easier to control than one in the tree crowns, and will cause less damage to your trees.

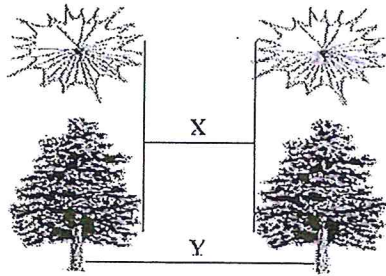

X = Crown Spacing
Y = Stem Spacing

Do not measure between stems for crown spacing. Measure between the edges of the tree crowns.

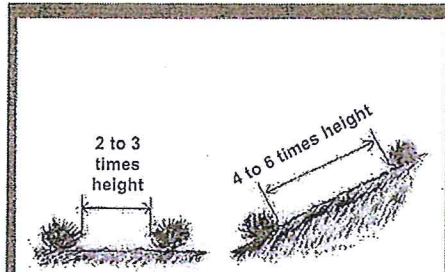

Maintain adequate cleared space between ornamental or wild shrubs.

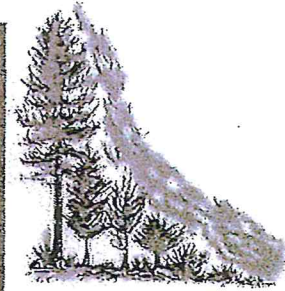

Ladder fuels are created when vegetation of different heights is close enough to allow a ground fire to climb up into tree tops.

PRUNING

- 🌳 In Zone 1, prune lower limbs up to 10' above ground level, with crown spacing of 10'.
- 🌳 In Zone 2, prune lower limbs of trees up to 10' above ground level, with crown spacing of 8'.
- 🌳 In Zone 3, prune lower limbs of trees up to at least 6'-10' above ground level, with crown spacing of 6-8'.
- 🌳 Prune tree branches around the structure to provide a 10 foot clearance from the roof and 15 feet from chimney.
- 🌳 For trees taller than 20 feet, prune the lower branches within ten feet of the ground.
- 🌳 For trees less than 20 feet, prune no more than 1/2 the total height of the tree.
- 🌳 In any case, never prune up more than 1/2 the total height of the tree.
- 🌳 Never cut into the collar around the branch at the trunk of the tree.
- 🌳 Do not cover wounds on branches.
- 🌳 If you are unsure about pruning on your property, ask your local Forester or Master Gardener.
- 🌳 If your property is in a Homeowner Association, be sure to check any covenants which might apply before modifying existing vegetation.

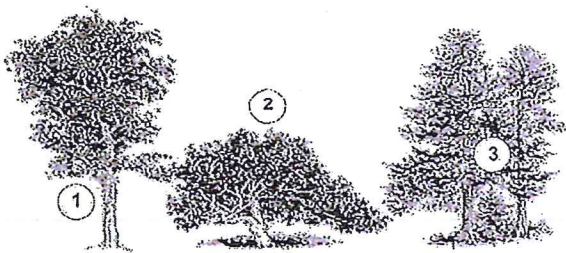

1. This tree has been trimmed so that no branches are close to the ground.
2. This small tree is close to the ground and can be more easily ignited from burning grasses.
3. Small trees growing underneath larger trees provide "ladder fuels" which allow grass fires to jump to the branches of the larger trees and spread even more rapidly.

LADDER FUELS

- 🌳 Thin trees to prevent interlocking crowns.
- 🌳 Remove or modify ground fuels so they cannot produce flame lengths more than six feet.
- 🌳 Remove "ladder fuels" - shrubs, brush, tall grass, dead vegetation, trash, and small trees underneath or close to large trees.
- 🌳 Shrubs and brush (fine) fuels have similar characteristics - all burn rapidly with high intensity.
- 🌳 Stack firewood and scrap woodpiles at least 10 feet from any structure.

DEFENSIBLE SPACE

FIREWISE LANDSCAPING

A well designed landscape around your home is the first step toward reducing risk from wildfire. *Maintaining* it is the second step. *All* vegetation is potential fuel for fire. There are no truly "fire proof" plants. All will burn if the conditions are right. There are, however, plants that are FIRE-PRONE, and those that are FIRE-RESISTANT.

FIRE-PRONE PLANTS

Traits include:

- needle-like or other fine leaves.
- resinous, oily or waxy foliage or wood.
- loose or papery bark.

Examples:

Most conifers
Common Juniper
Rocky Mountain Juniper

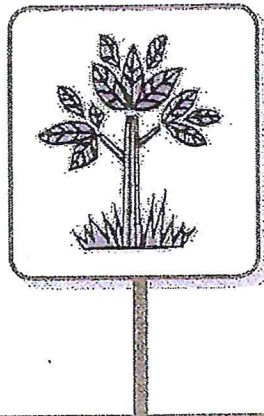

FIRE-RESISTANT PLANTS

Traits include:

- little or no seasonal accumulation of dead leaves.
- non-resinous wood and leaves.
- high moisture content of leaves.

Examples:

Cottonwood Aspens
Roses Red-osier dogwood
Ashes Littleleaf sumac
Lilacs Chokecherry

Plants for a FIREWISE LANDSCAPE have one or more of the following characteristics:

EXAMPLES:

- | | | |
|---|---|--|
| • They grow without accumulating large amounts of combustible dead branches, leaves or needles. | S | • Aspen. |
| • They have open, loose branches with a low volume of total vegetation. | S | • Currant, mahogany, mountain maple. |
| • They have low sap or resin content. | S | • Many deciduous species: Aspen, Cottonwood, Mountain Ash. |
| • They have high moisture content. | S | • Succulents, some herbaceous species. |
| • They grow slowly and need little maintenance or frequent pruning. | S | • Ash, Cottonwood. |
| • They are short and grow close to the ground. | S | • Wildflowers and groundcovers. |

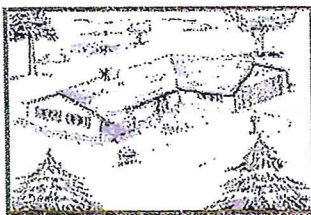

Design your landscaping to include a combination of fire-resistant plants/trees and noncombustible *hardscape* materials, such as decorative stone/brick walls, patios, decorative stone borders around the foundation, stone or brick fences, or a stone or brick pillar in a wood fence separating the fence from the house.



Any structures attached to the house, such as decks, porches, fences, outbuildings and sheds *should be considered part of the house*. These structures can act as fuses or fuel bridges, especially if constructed from flammable materials. Look at existing natural firebreaks on your property and incorporate them into your design. Examples include utility rights-of-way, roads, trails, meadows, rocky areas and streams.

STRUCTURE DESIGN

BUILDING MATERIALS

Ratings

In discussing building materials and components we make frequent references to ratings. Various national organizations provide ratings or evaluations for the fire resistivity of materials or building assemblies by testing them. A building assembly is a combination of materials forming a component of a building such as a roof or wall. Ratings are based on the assembly and layering of those building materials and the *burn time* before ignition, and are divided into classes:

Classes: A (the best— 2 to 4 hrs)
B (1hr)
C (20 min)

Material Class is also categorized by composition, or resistance to fire (combustible vs noncombustible).

Material Classification (in general):

Class A Inorganic materials (metal, brick, tile)
Class B Whole wood materials (usually pressure treated, or thick diameter)
Class C Reconstituted wood (plywood, particle board, hardboard etc.)

Class A has the highest resistance; Class C has the least resistance. However, Class A materials generally need an underlayment of additional materials to obtain Class A *Ratings*. This is because Class A materials conduct heat beyond the exterior.

The organizations that provide these ratings are: the International Code Council (ICC) International Code Council (ICC) through its publication the International Building Code (IBC); the International Conference of Building Officials (ICBO) through their publication, the Uniform Building Code (UBC); the Building Officials and Code Administrators International, Inc. (BOCA); the Southern Building Code Congress International (SBCCI); the American Society for Testing and Materials (ASTM); the Underwriters Laboratory (UL); and the National Fire Protection Association (NFPA).

The difference between a noncombustible material and a rated material or assembly is the surface resistance to ignition versus the protection afforded the building behind it. A good example of a non-combustible material is metal roofing and siding. Metal is non-combustible, but an excellent conductor of heat. If the fire remains present long enough, the heat will be conducted through the metal and ignite the material behind it.

An example of a fire rated assembly is wood siding applied over gypsum sheathing. This assembly is rated as one hour. The surface can ignite but the building is protected from the fire for one hour. The importance of this is the difference between intensity of fire and the amount of time the surface is exposed to the fire. The ratings were established originally for commercial buildings in urban settings, but have been expanded to incorporate residential structures and structures in a wildland-urban interface area. For example the wall between a garage and a house must be rated as one-hour fire resistive, and the door between the garage and the house must have at least a C label rated for twenty minutes with an automatic closer.

The two main fire resistance tests used today for roofing materials include: ASTM E108 and UL 790. There are three levels of classification awarded under the test protocol; A, B, and C, with A being the most fire resistant. Some chemically treated wood shake shingle products have ratings of Class C or better. Over time, the effectiveness of this chemical is reduced by weathering before the end of the product's useful life and may leave your roof unprotected. If your roof needs to be re-covered consider installing a Class A roof covering.

Materials ratings for the wildland-urban fire environment have been directly addressed by the ICBO, through a subsidiary, the International Code Council and its publication, the *2003 International Urban-Wildland Interface Code*, and the National Fire Protection Association (NFPA) *Standard 1144*. These publications also address other issues covered in this publication, such as access, utilities, and water supplies for fire suppression. Much of what is contained in this publication is based on, or refers to these publications.

STRUCTURE DESIGN

STRUCTURE DESIGN

DESIGN CONCEPTS

So far we have discussed basic fire behavior and how to manage the wildland or forested area surrounding your structure. The second part of our approach will focus on learning about Firewise structure design and fire resistant materials.

The most important consideration in the design for a new structure or remodeling project, *is the site itself*, and all of the features incorporated in that site that we previously discussed.

Each site is **UNIQUE**; unique in its topography, slope, aspect, vegetation, weather exposure, and the individual goals of the property owner for that location and structure. The site must be viewed from its own unique perspective as the first step in the design process. So, there really is no "cookie-cutter" approach, or "one-size-fits-all" design criteria.

However, we will recommend several Firewise design concepts and construction materials that have been tested and proven to make structures more ignition resistant in the event of a wildland fire. Remember that ignition is a function of the amount of heat applied to a structure and the length of time that heat is applied.

Simple or Complex Designs:

Simple structure designs have less surface area relative to the volume of the building. Complex designs have much more surface area relative to the volume of the building. Simple designs are generally less expensive to build, more energy efficient, and easier to protect from wildland fires. There is simply less exterior surface area to protect.

Complex designs not only increase the surface area of the structure, but they create shapes that trap the effects from a fire. These are called *heat traps*. Transitions from horizontal to vertical surfaces, inside corners, abrupt intersections of solid planes, all form air pockets where wind speed drops and eddy currents form.

When wind speed falls, it usually drops more of the burning embers it carries at these heat trap locations. Parapet walls, solar collectors, roofs that intersect walls, roof valleys, and decks are just some examples of heat traps.

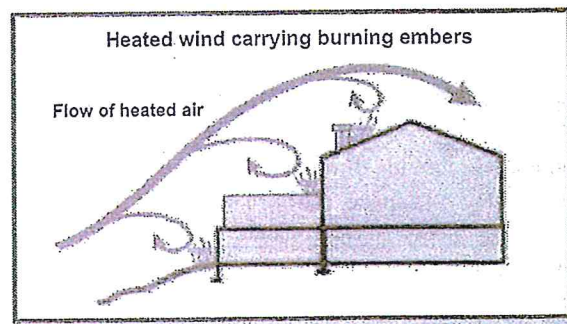
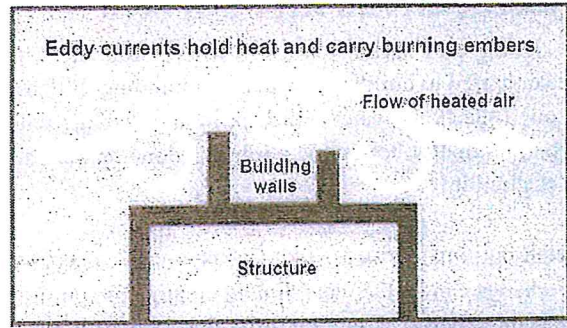

Of course, you can't avoid some of these shapes and forms, but those heat trap locations will require much more fire resistive materials. Roofs are very susceptible to firebrands, especially in a wind driven fire. A simple roof, like a hip or straight gable, is best and creates the least exposure. Complicated roofs with intersecting planes, valleys and angles, form these dead air pockets and eddy currents.

This is not intended to discourage the use of complicated designs, but rather to highlight the potential dangers and the importance of a fire resistive roof and roofing materials. Your structure design can vary from these principles, but then more fire resistive materials and components must be applied when simple forms and optimum aspect ratios cannot be used.

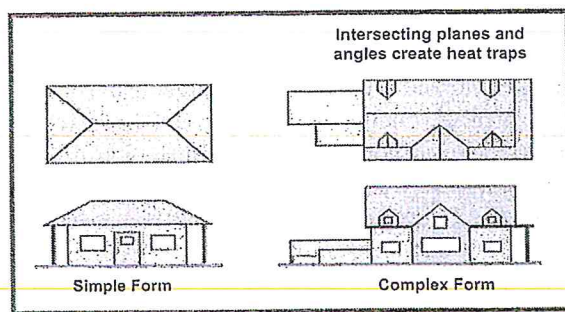

STRUCTURE DESIGN

VENTS, EAVES AND SOFFITS

VENTS, EAVES AND SOFFITS

Designing and building a fire resistive structure can be compared to building a watertight building. If there is one little hole, water will leak in and damage will occur, no matter how good a job was done on the rest of the building.

Small building elements like soffits, vents, eaves and overhangs can be the weak link in creating an ignition resistant structure, allowing fire to find its way through these areas and the structure can burn down from the inside out.

Roof, Attic & Foundation Vents

Wind or direct contact with a fire's convective heat can push firebrands through vents into the structure's basement, crawl space, roof or attic.

Building codes typically allow alternatives to traditional vents. In some cases louvered vents are permitted. These can be closed when moisture is not a problem. (Fire season is usually the dry season.)

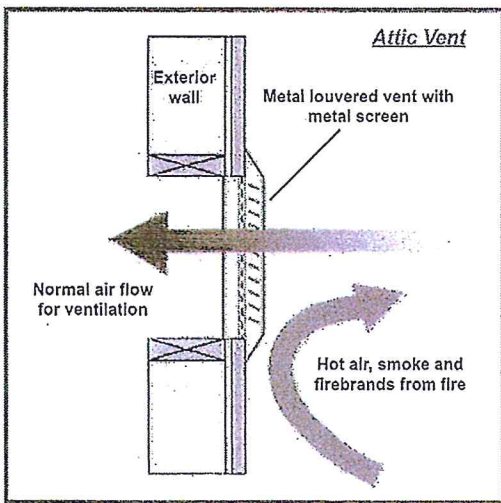

Vent openings should be covered with metal screen to prevent firebrands or other objects larger than 1/4 inch from entering your home. Both the vents and screens, louvers, and vent covers/frames should be constructed of materials that will not burn or melt when exposed to radiant or convective heat or firebrands. Vent materials should also be corrosion-resistant to help minimize required maintenance.

All crawl spaces under wood floors are also required to have ventilation. Since these vents are typically located near the ground, care should be taken to not have any combustible vegetation immediately next to them. Vents located on the downhill side of the house should have landscaping elements, like stone patios or fire resistant walls that can block the direct path of the fire.

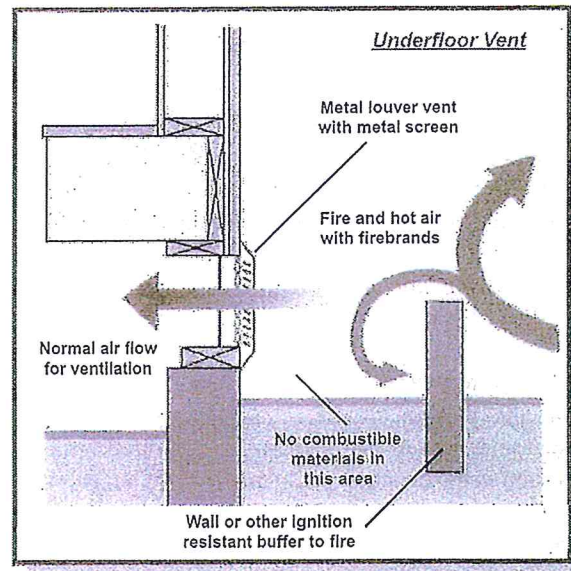

The 2003 *International Urban-Wildland Interface Code* states for Class 1, Class 2 and Class 3 Ignition Resistant Construction, "Attic ventilation openings, foundation or under floor vents, or other ventilation openings in vertical exterior walls, and vents through roofs shall not exceed 144-square inches each. Such vents shall be covered with noncombustible corrosion-resistant mesh with openings not to exceed 1/4 inch. Underfloor ventilation openings shall be located as close to grade as possible."

"8.2.2 Vents shall be screened with a corrosion-resistant, non-combustible wire mesh with the mesh opening not to exceed nominal 6.3 mm (1/4 in.) in size. Vents should be located in walls that do not face slopes or heavy fuels." *NFPA 1144, Standard for Protection of Life and Property from Wildfire, 2002 Edition*

Vents are required by most building codes to allow internal air circulation and prevent the accumulation of water vapor. Most building codes require all attic spaces and roof cavities to have ventilation - one square foot of vent for every 300 square feet of roof.

STRUCTURE DESIGN

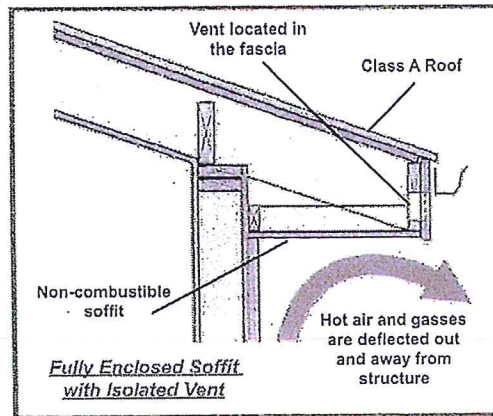
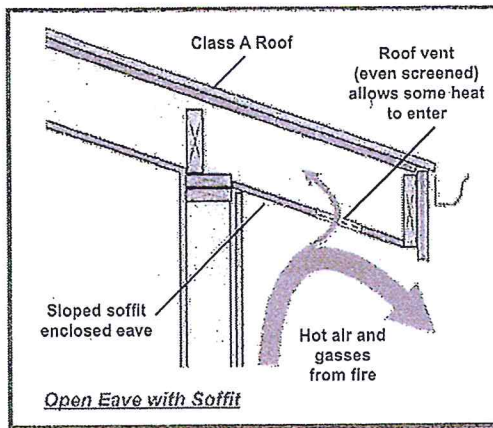
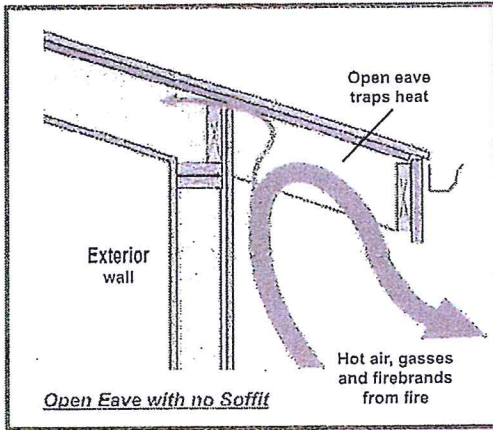

near the roof line and close to the fascia. The vent can also be placed in the fascia.

Eaves, Fascias and Soffits

The eaves are the part of the roof that overhangs the structure walls and provide weather protection for the siding. Wide eaves provide additional protection from sun, rain and snow. But they are also particularly prone to ignition because they interrupt wind flow, creating eddies that have the potential to trap convective heat and burning embers. As fire approaches the building, the exterior wall deflects the hot air and gasses up into the eave. If the exterior wall is combustible this effect is amplified.

The solution is to "box" or enclose the eave with a soffit. Eaves, fascias and soffits should be noncombustible materials. If the soffit is applied directly to the rafter eave, it forms a sloping soffit. This still makes a pocket that potentially can trap fire. A better detail is to form a flat soffit that allows the building to more readily deflect fire outward. The soffit material should be at least 3/4 inch plywood in low fire hazard areas, noncombustible in moderate and high areas, and one-hour rated material in very high hazard areas.

A final consideration is the air space between the insulation and the inside of the roof. Burning embers and hot gasses can be drawn into this space through vents and possibly ignite the insulation. The solution is to ensure the insulation is fire resistive. Check with the insulation manufacturer to obtain material classification and fire resistance ratings.

The 2003 *International Urban-Wildland Interface Code* calls for, "Protection of eaves. Eaves and soffits shall be protected on the exposed underside by materials approved for a minimum of 1-hour fire-resistance-rated construction. Fascias are required and must be protected on the backside by materials approved for a minimum of 1-hour fire-resistance-rated construction or 2-inch (51 mm) nominal dimension lumber."

Vents for roof ventilation are often found in the soffit or under eaves. Placing vents in these locations creates a perfect path for fire to enter the roof structure. If the vent must be in this location, it should be placed as far from the wall as possible (nearest the rafter ends),

"8.2.3 Eaves shall be boxed in with 15.8 mm (5/8 in.) nominal sheathing or noncombustible materials." *NFPA 1144, Standard for Protection of Life and Property from Wildfire, 2002 Edition*

STRUCTURE DESIGN

MECHANICAL VENTILATION

Window Fans

Permanently mounted or temporary window fans usually draw air in rather than exhaust air. In a wildfire situation, the former could draw firebrands in, while the latter would suck firebrands in through unscreened fresh air intakes, wherever they are. All exhaust or intake openings should be covered with screen as described earlier.

Whole House Air-Conditioners, Heat Pumps, Window or Through-The-Wall-Air-Conditioners

Typically, no openings exist directly between the outside and inside. If the fresh air intake (make-up air) option is running, smoke can be drawn into the structure, but drawing-in firebrands is not likely.

Evaporative Coolers (Swamp Coolers)

Except for a closed interior louver (usually made of plastic), the wood excelsior or fiber material which provides the evaporative surfaces are the only barrier between the outside and inside. If these pads are dry, they might ignite. If the system is running, firebrands will be blown into the structure. Even if not running, burning pads or pads already burned could allow embers into the structure. Rooftop units are especially vulnerable. Screening (as discussed earlier) should be installed between the pad and the heavy wire pad keeper.

Whole House Fans

Typically, these fans exhaust heated inside air through the attic, drawing outside air (make-up air) through open windows or other vents. Some fans are controlled by a thermostat which turns the fan on when the attic temperature reaches a certain point. If the windows and vents are screened, only smoke will be drawn into the structure. If not screened, firebrands and embers can be drawn-in and the draft created by the fan will rapidly spread the fire inside. Metal, self-closing louvers should be installed along with a sensing switch that would turn the fan off at high temperatures.

Turbine Ventilators

Rooftop turbine ventilators should be removed and wire screen installed under the turbine. In new construction, installing the screen on the roof under the turbine flashing may be easier.

WINDOWS & GLASS

No material is "fire proof." However, the proper use and assembly of fire-rated building materials can reduce a fire's spread, and extend the amount of time it takes for a home to ignite and burn. Windows are the weakest component of your home in relation to wildfire. They usually break and dislodge before the building ignites, providing a direct path for flames and firebrands to reach the building interior.

Glass provides only a partial barrier to fire, and only for a short time. Regular plate glass often breaks due to rapid changes in temperature, or bombardment by windblown projectiles. It fractures in the presence of heat and, in the case of a wildland fire, this will happen in about five minutes. Glass deflects most of the convective energy, but not the radiant energy of the fire. This applies to glass in windows, doors and skylights.

Convective Energy is hot air and gasses. About 70% of the heat is deflected away by window glass, about 20% of the heat is absorbed, and 10% of the heat is transmitted to the interior of the building.

Radiant Energy from a fire is infrared light energy, like the energy we experience from the sun. Of the radiant energy from a fire, 70% is transmitted through the glass to the interior of the building, about 10% is reflected, and about 20% is absorbed by window glass.

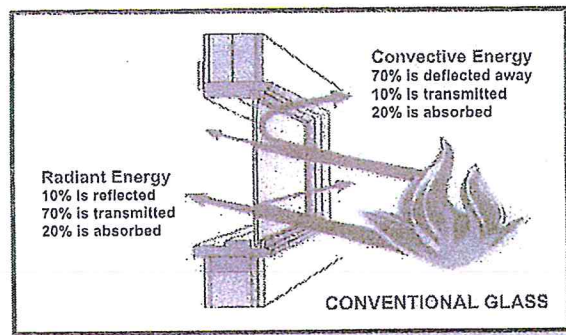

"Single-pane, plate-glass windows can thermally fracture and fall out at fire exposures insufficient to ignite exterior wood materials. A window opening provides an entry point for firebrands, greatly increasing the chances for ignition. Double-pane, plate-glass windows also fracture and fall out, but they can be exposed to heat for longer periods before potential

window collapse. Importantly, experiments showed that tempered glass has a much higher resistance to heat fracturing than plate-glass window glazing." (*Structure Ignition Assessment Can Help Reduce Fire Damages In The W-Ul*, Jack Cohen and Jim Saveland, 1997)

Low E and Tempered Glass

Tempered glass is resistant to high impact and high heat, while Low E (low emissivity) glass stops the transfer of radiant heat beyond its exterior. The combination of the two provides the best protection in a wildland fire.

Low E Glass

Low E stands for low emissivity. This is an ultra thin, several microns thick, metallic coating on glass that appears white or reflective to infrared and ultraviolet light. It is used in windows for energy efficiency because they hold more heat in during the winter and keep more heat out during the summer. It also protects fabrics from fading and wood from yellowing. This glazing option is widely used in windows today and costs about 10% more than standard double glazed units.

The advantage of this glass in a wildland fire is that it stops the radiant energy transfer to combustible materials that are behind the glass such as drapes or wood furniture and walls.

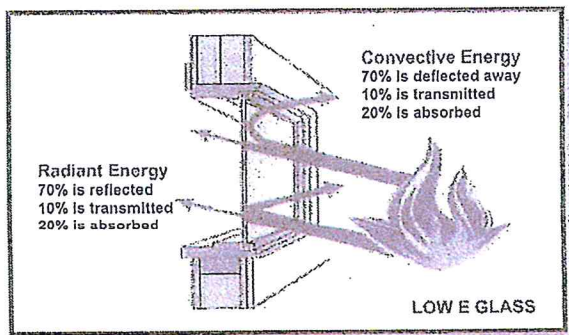

Tempered Glass is both resistant to high impacts and high heat. Most of us are familiar with it. Most building codes require that tempered glass be used in patio doors (sliding glass doors) and all areas subject to human impact. It is also the glass used in front of fireplaces.

Tempered glass will usually stay in place and intact through a wildland fire event. Windows with tempered glass typically cost 25-50% more than regular glass.

Existing windows can be easily be retrofitted with tempered glass where they are most likely to be exposed to a wildfire. Another consideration, if this proves too costly, is Firewise landscaping around the window to avoid direct contact by flame.

The combination of low E and tempered glass features for windows provides the best possible solution for windows in a wildland fire. The glass will generally stay intact throughout the fire event and it will transfer less radiant energy to combustibles behind it.

Thermopane or Double Glazed Windows

Because of current energy codes, most glass today is double glazed or Thermopane. Thermopane or double-glazed glass, with air space in between the two pieces of glass, will last twice as long as conventional glass windows (ten minutes). The same effect of convective and radiant energy apply, but, because there are two layers, the second pane is protected until the glass on the first has completely failed and fallen away.

As shown earlier in the fire behavior section, the duration of a fire at a site is dependent on the slope and the fuels and can be as short as ten minutes in the case of a grass slope fire.

If the duration of the fire is any longer than ten minutes because there is a good fuel supply around the house, or preheating from a fire approaching from below, additional protection will be necessary to prevent glass failure and fire entering the house.

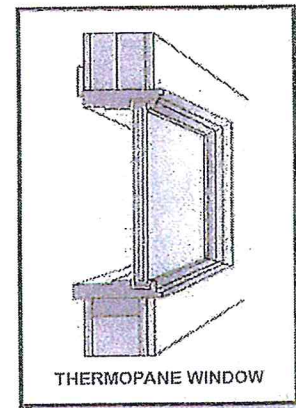

Glass Block

Glass block is the most fire resistive glass available in that it has the highest fire resistive glass rating of 90 minutes. It has an excellent appearance but provides a poor view. It does not have the Low E option. A good use may be in a situation where only day-lighting is needed, a view is not a factor, and the orientation of the window may be towards a very high fire hazard.

STRUCTURE DESIGN

Large vs. Small Windows

Both the radiant and convective energy heats the glass but the perimeter of the glass is covered and protected by a sash. This causes a differential heating of the glass, stresses the glass, and causes it to crack.

If fractured glass stays in place during a fire it can continue to shield hot gasses (convective energy), firebrands and open flame from entering your home. However, radiant energy can eventually ignite combustible materials behind the window even with glass in place.

Small windows, less than two feet on a side, will keep fractured glass in place better than larger windows, because the size of glass held in place by the sash is relatively small with little weight.

Large windows (more than two feet on a side) cannot keep the fractured glass in place because the size and weight of glass in relationship to the length of the sash is too great.

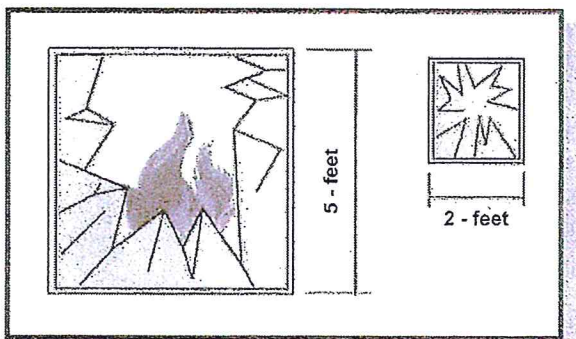

"Exterior glazing. Exterior windows, window walls and glazed doors, windows within exterior doors, and skylights shall be tempered glass, multi-layered glazed panels, glass block or have a fire protection rating of not less than 20 minutes." 2003 International Urban-Wildland Interface Code - 504.8

Windows and glass do not have "Material Classification" labels that other building materials have, but the same concept applies. Understand the difference between material *Class* and *Rating*, and use this knowledge when upgrading around your home.

Frames and Sashes

Windows with improved glass technology will only work as long as the glass remains in place. The glass is held by the frame so the frame needs to also withstand the fire.

Wood frames will burn. Since they have a high surface to volume ratio they will not only readily ignite, but will also burn freely. They are not a good choice.

Vinyl frames seldom ignite, and if they do, the combustion rate is very slow and does not contribute to the combustion of the house. The problem is that vinyl frames melt and structurally fail, allowing the glass to fall away. They are not a good choice either.

Aluminum clad wood. The aluminum cover on a wood frame delays the ignition of the wood window. It does not completely protect the window because the aluminum conducts the heat to the wood, but this delay is usually enough in most wildland fires.

All-aluminum frames are even better. Since there are no combustible materials, they remain fully intact during a fire. These frames are available with a thermal break, a plastic spine that connects the interior frame to the exterior frame, which makes its thermal performance nearly as good as wood frames.

Exterior Window Covers, Shutters, Screens

Only an additional ten to twenty minutes of protection is necessary for a window to survive a fire. Exterior window covers, such as in-place shutters that only need to be swung into place, can add this time. Shutters originated in New England as protection from storms when the wind would break the glass, and are now readily available in the Florida area for hurricane protection.

Wood shutters are the most common and economical, but they will ignite within five minutes. However, as shown in the fire behavior section, if the wildland fire duration is short enough, an additional five minutes of protection may be all that's needed. Also, even though fire departments may use foam to protect structures, foam will not stick to glass, so shutters may still be advisable.

STRUCTURE DESIGN

Better still are *metal shutters*. They will protect the window long enough to last through the fire event, and will not ignite.

The disadvantage of shutters is that they are not completely passive, that is, they require intervention on the part of the homeowner or the fire department to be effective.

Permanently placed *metal screens* eliminate the deployment problem. Exterior screens are not going to protect the window as much as a solid cover, but as mentioned before, only five to ten minutes of additional protection may be needed, and they provide a surface for foam to adhere to. These screens cannot be used with outward acting windows, like casement or awning windows, but they can be used with horizontal sliding and double hung windows.

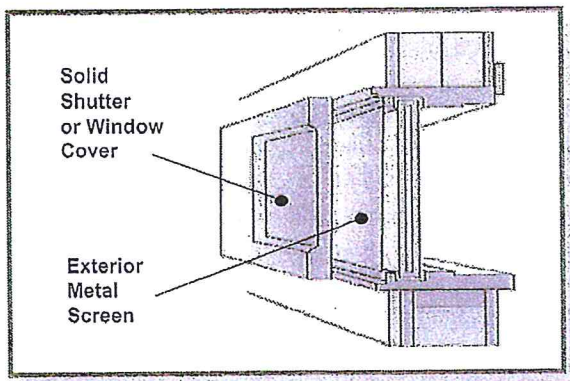

Skylights can also be a potential entry point for fire. Plastic skylights can melt under the intense heat and flying embers.

One significant way to protect the structure in the event of a wildfire is to cover windows and skylights with non-flammable screening and shutters.

In general, the structure should have at least two ground level doors for safe and easy exit, and at least two means of escape (doors or windows) in each room.

"8.6.1 Exterior windows and glazed doors, windows within exterior doors, and skylights shall be tempered glass, multilayered glass panels, glass block, or have a fire-resistance rating of no less than 20 minutes." NFPA 1144, Standard for Protection of Life and Property from Wildfire, 2002 Edition

DOORS

Exterior doors are how you get into and out of the structure. They can also be how a fire gets inside.

Wood Doors

Residential buildings typically use wood doors with glass inserts. The same fire issues related to window glass apply to glass in doors. An un-rated wood door is typically 1-1/2 to 2 inches thick, and can readily ignite and burn through in only ten minutes, much faster than the rest of the structure will burn.

Wood doors are available with a class C, 20-minute rating. These doors are typically used between the garage and the house and are a good solution in moderate fire hazard situations. But in very high fire hazard situations, they may not be appropriate because the door will burn according to its rated time. This may be long enough to ignite other exterior building components.

Metal Doors - Steel and Aluminum

Metal doors are non-combustible and available with 20-minute, 45-minute and 1-1/2 hour ratings, which makes them the most appropriate solution for very high hazard situations. Glass sizes are restricted in these doors. The surfaces are available with embossing to simulate wood grain and raised panel designs.

Just as in energy conservation, a good fire resistive door requires adequate weather stripping so that the seal prevents hot gasses or burning embers from entering through gaps around the door.

"504.9 Exterior doors. Exterior doors shall be approved non-combustible construction, solid core wood not less than 1-3/4 inches thick (45mm), or have a fire protection rating of not less than 20 minutes. Windows within doors and glazed doors shall be in accordance with Section 504.8. Exception: Vehicle access doors." 2003 International Urban-Wildland Interface Code

"8.6.2 Exterior doors shall be approved noncombustible construction, solid core wood no less than 44.5 mm (1.75 in.) thick, or have a fire protection rating of no less than 20 minutes." NFPA 1144, Standard for Protection of Life and Property from Wildfire, 2002 Edition

DOORS

STRUCTURE DESIGN

ROOFS

The roof is the most vulnerable part of the structure to wildfires. During a wildfire, firebrands can fall on the roof, landing in nooks and crannies where a fire can easily start. Once the roof covering does ignite, chances are very good that the rest of the structure will follow. The best way to avoid this situation is to make sure the roof is fire-resistant.

No material is "fire proof," however, proper use and assembly of fire-rated building materials can reduce a fire's spread and extend the amount of time it takes for a home to ignite and burn. (Structural assembly is the process of layering materials when building exterior walls and roofs). A fire-resistant sub-roof will provide additional protection needed without sacrificing anything in the design. The roof is vulnerable to wildfire because it is the largest exposed surface area of the structure. Since most roofing has a rough surface and numerous cracks, it can trap wind blown embers and firebrands. Simple roof forms are easier to protect than complex ones due to less surface area and intersections, which may create heat and burning ember traps.

The two main fire resistance tests used today include: *ASTM E108* and *UL 790*. There are three levels of classification awarded under the test protocol, A, B, and C. Material Class is categorized by composition or resistance to fire (combustible or noncombustible). Class A has the highest resistance, Class C has the least resistance.

However, Class A materials generally need an underlayment of additional materials to give it an A rating, because Class A materials conduct heat beyond the exterior. Class C is the minimum level required by law. Contact the local fire department and building codes for area specific roofing guidelines and requirements.

Material Classification Examples

Class A - Brick, Concrete Tile, Slate, Clay, Asphalt, Metal, Fiber-cement, Terra-cotta Tile

Class B - Pressure-treated shakes and shingles

Class C - Wood shakes and shingles, Plywood, Particleboard

"Section 504 - Class 1 Ignition-Resistant Construction: 504.2 Roof covering. Roofs shall have a Class A roof covering or a Class A roof assembly. For roof coverings where the profile allows a space between the roof covering and roof decking, the space at the eave ends shall be firestopped to preclude entry of flames or embers". 2003 International Urban-Wildland Interface Code

Wood Shakes and Shingles

They are thin, 1/2 to 1 inch thick, with a very rough surface and many cracks. The thin physical make-up and surface structure of wood shakes and shingles are readily combustible. Some treated wood shake shingle products have ratings of Class C or better. Pressure treatment with chemicals can change wood shingles to a class B or C roof. Chemically treated cedar roofs built with a gypsum underlayment can have a class A assembly rating. Over time, the effectiveness of this chemical is reduced by weathering before the end of the product's useful life and may leave the roof unprotected, unless it is routinely retreated.

Another important characteristic of wood roofs is that they dry out in climate of low humidity, high winds, elevated ultraviolet radiation and extreme temperature variations. When a wood roof burns it also lofts burning embers, contributing to the spread of fire. Other fire resistant products are described in this section that are available and simulate the look of wood shakes.

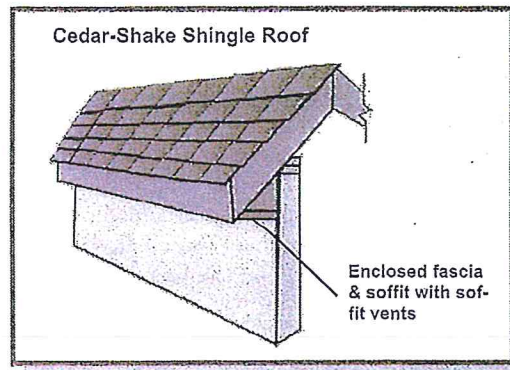

Asphalt Shingles

Asphalt shingles are probably the most economical way to roof a building, especially in terms of dollars spent per years of guaranteed life. Conventional mineral reinforced asphalt shingles have been available for more than 60 years.

STRUCTURE DESIGN

They are normally guaranteed for 10 to 20 years, and usually have a class C rating. Mineral reinforced shingles have gradually been replaced by fiberglass reinforced asphalt shingles. These offer guarantees of 20 to 40 years and are a class A material. They are available in many colors and textures and can even imitate wood or slate shingles.

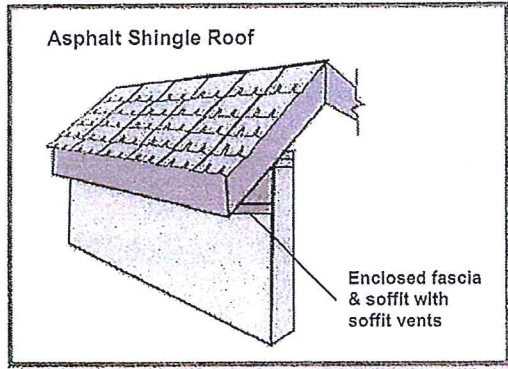

Metal - Sheets and Shingles

The advantage of metal roofing is that it is sturdy, very lightweight, and non-combustible. It is available in sheet form in many colors. It usually has standing seams or ribs. Metal roofing comes in the form of painted galvanized steel, painted aluminum, stainless steel, and copper. The most common metal roof is galvanized steel with factory-applied paint (usually a two-part epoxy type, not too different from automobile paint). Metal roofing is also available as an imitation wood shingle, made by stamping a texture and shape on the metal and then applying the appropriate color. This imitation is so good that at a distance of 100 feet or more it is difficult to tell the difference between it and a wood shingle. It requires a gypsum underlayment in order to have a Class A assembly rating. Guarantees start at 20 years and go to 50 years.

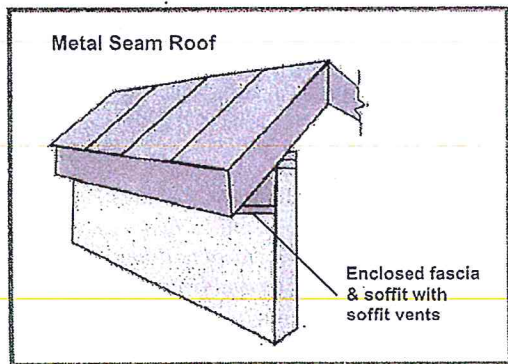

Fiber-Cement Shingles

These synthetic shingles are manufactured with a mixture of cement and fiberglass, or cement and wood. Like the metal shingle, they are made to imitate a wood shingle's texture, shape and color. The cement in these products is altered with polymers to make it less brittle. They are a noncombustible material, but require a gypsum underlayment for a Class A assembly rating.

Membrane Roofs

These hard or semi-solid materials are usually applied to flat roofs and are slightly combustible. These materials include both rubber and hot tar applied, bituminous saturated mineral felt for flat roofs. These materials are marginally combustible but are most often used with other covering systems like concrete. They can be applied over a gypsum underlayment for a class A assembly rating. Guarantees are only in the 10 to 20 year range, but these products can be considered permanent when covered with concrete.

Tile, Clay Tile, Concrete and Slate Shingles

These products provide the best fire-resistive roof, but can be more expensive than other roofing alternatives. They are 1 inch thick, heavy (10 pounds per square foot), noncombustible, Class A rated and usually come with 50 year guarantees. Concrete shingles can be manufactured to look like wood shingles. When installing a tile roof, the round openings of the tiles at the edge of the roof need to be enclosed.

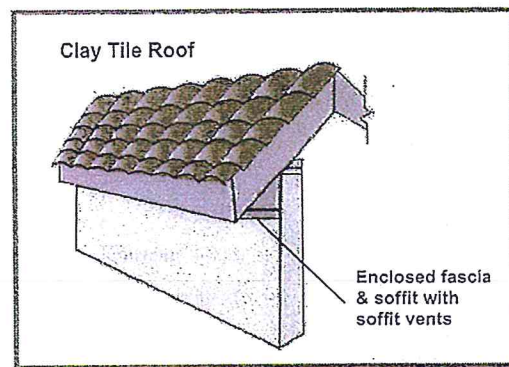

"8.2 Roof Design and Materials. 8.2.1 The requirements for roof covering assemblies shall be as follows: (1) Only roof covering assemblies rated Class A, B, or C shall be used." NFPA 1144, Standard for Protection of Life and Property from Wildfire, 2002 Edition

STRUCTURE DESIGN

DECKS

Decks are a very popular, well-used feature of many homes. However, they often face downhill towards a fire's most likely up-slope approach. Decks are built perfectly to burn, almost as easily as wood stacked in a fireplace. When fire approaches, the wood quickly dries out and heats up. Ignition can occur very easily when either the radiant energy from the fire gets hot enough or a burning ember lands on it, often before approaching wildfire ever reaches the structure.

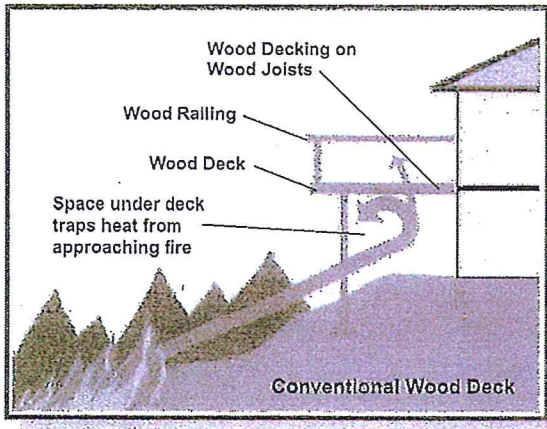

Conventional Wood Decks

Conventional wood decks are highly combustible. Typically, their constructional design makes them vulnerable to convective energy, wind blown embers, and trapped hot gasses. Components of conventional wood decking are made of two inch thick wood with high surface to volume ratios making them readily combustible and conducive to fire spread.

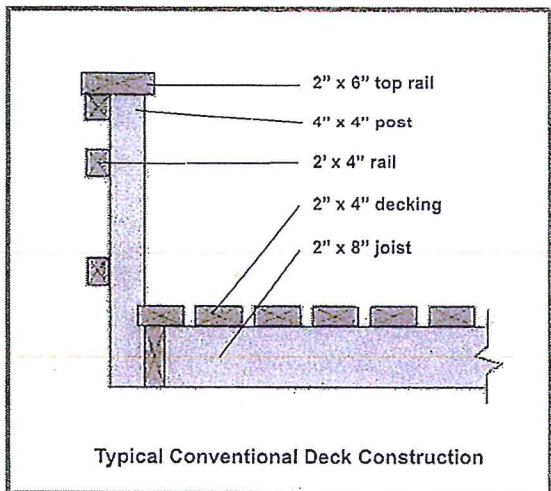

Heavy Timber Decks

In moderate fire hazard areas the use of heavy timber construction is acceptable. The low surface-to-volume ratio of heavy timber takes longer to burn. Minimum thickness for a heavy timber deck is 6 inches for the posts and structural members and 3 inches for the decking and rails.

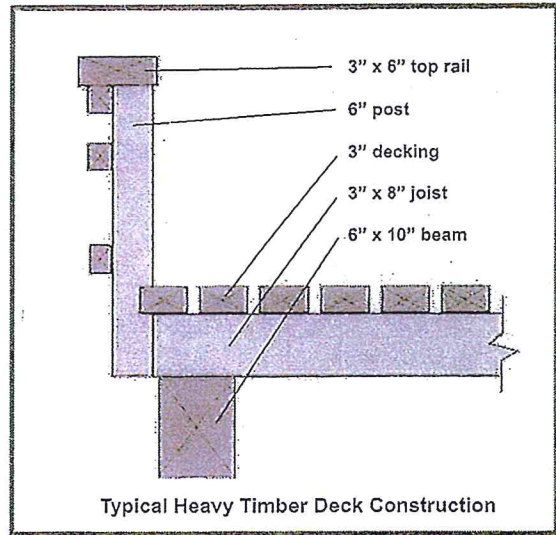

Isolate the deck from fire with a patio and wall. If possible isolate the deck from fuels and fire by building a noncombustible patio and wall below it. A patio will ensure that no combustible materials are below the deck. The wall will act as a shield, deflecting both radiant heat and hot gasses from the fire.

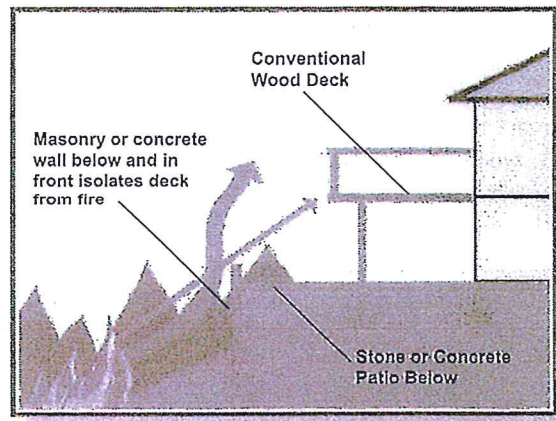

"8.3 Overhanging Projections. Porches, decks, balconies, and similar overhanging projections shall be constructed of heavy timber, as defined by local building standards, a 1-hour fire resistive-rated assembly, or noncombustible materials." NFPA 1144, Standard for Protection of Life and Property from Wildfire, 2002 Edition

STRUCTURE DESIGN

Fire-Resistive Decks

In the highest fire hazard areas, use noncombustible surfaces and fire-resistive building materials for a deck. Wood frame construction is permitted, but the surface should be noncombustible or one-hour rated materials. To build this type of surface, place a waterproof membrane over the top of the deck. This allows the use of fire-resistive soffit materials which cannot tolerate moisture.

The most common materials are cement fiber panels or metal (noncombustible), or gypsum (noncombustible and one-hour rated). Cover the membrane with decking; plastic wood has low combustibility, it will burn but only very slowly. A better material is 1 to 2 inches of concrete or stone. This surface is fireproof and protects the deck from air-borne firebrands. However, this covering material requires that the structure be strengthened to support the additional weight. Posts and railings can be economically built from steel. Wood posts near the ground can have stone, brick, or noncombustible coverings. Steel pipe, usually 1 to 2 inches in diameter, is very economical and easy to work with. Square steel shapes can look like traditional wood railings.

Fully Enclosed Decks

The best design is to convert the deck to a solid form by fully enclosing it. Enclose the undersides of balconies and decks on slopes with fire resistive materials, like non flammable siding backed by wire screen. This completely eliminates the heat trap and areas that can trap flames and burning embers. This form also complies with the 2003 Urban/Wildland Interface Code.

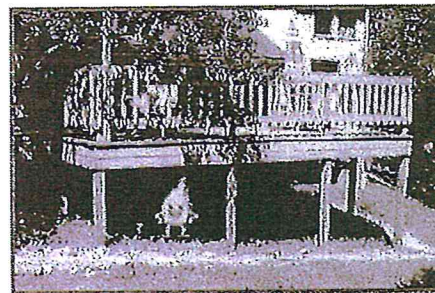
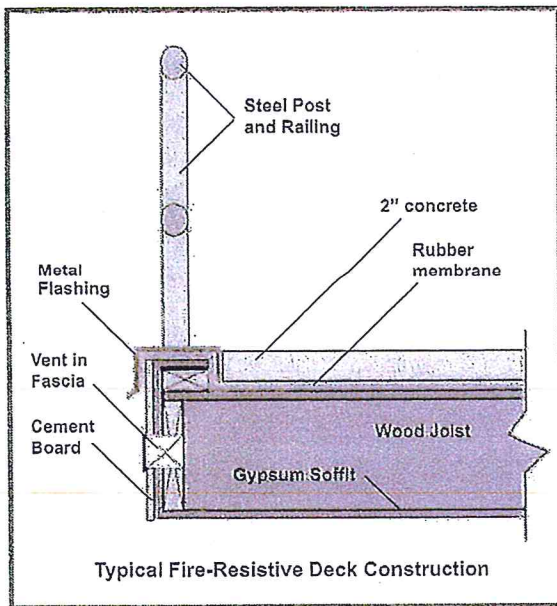
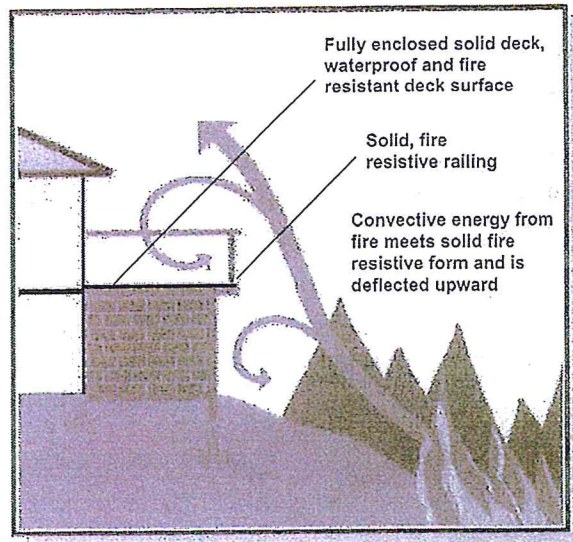

BEFORE

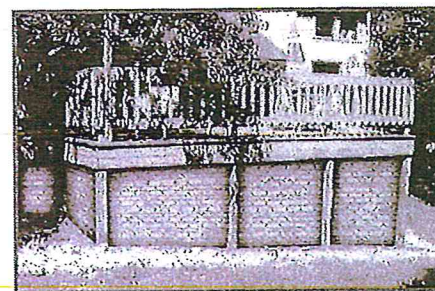

AFTER

STRUCTURE DESIGN

Composite Decking

Composite decking is a mixture of recycled contents (generally wood and plastic). It's very durable and has a high resistance to environmental weathering. It requires no sealants and is noncombustible. However, even though this material will not ignite, it can melt in a fire and cause the structural integrity of the deck to fail. Not all composite decking materials have been rated for fire resistance. Some ignite at fairly low temperatures, some just melt. No known tests have been done on the toxicity of fumes released by this melted material.

The same structural assembly rules apply with fire-resistive materials here as with home construction. The combination of noncombustible and rated materials can offer longer protection than a single material by itself. However, additional layering of materials will require a reinforced structural support.

Material Classification

Ratings are based on the assembly and layering of building materials and the burn time before ignition.

Class A (2-4 hours) & Class B (1-hour)

Heavy timber log (minimum of 6 inch diameter), Brick, Stone, Concrete, Concrete synthetic stone, Composition decking, Metal/steel, Membrane, Fiber cement

Class C (20-min.)

Wood panels and boards

"8.4 Overhanging Projections. porches, decks, balconies, similar overhanging projections shall be constructed of heavy timber, as defined by local building standards, a 1-hour fire-resistance-rated assembly, or noncombustible materials." NFPA 1144, Standard for Protection of Life and Property from Wildfire, 2002 Edition

"504.7 Appendages and projections. Un-enclosed accessory structures attached to buildings with habitable spaces and projections, such as decks, shall be a minimum of 1-hour fire-resistance-rated construction, heavy timber construction or constructed of approved noncombustible materials. When the attached structure is located and constructed so that the structure or any portion thereof projects over a descending slope surface greater than 10 percent, the area below the structure shall have all underfloor areas enclosed to within 6 inches (152 mm) of the ground, with exterior wall construction in accordance with Section 504.5." 2003 International Urban-Wildland Interface Code

Attached/Detached Structures

Overhangs and other attachments include any additional structures attached to a residence such as room pushouts, bay windows, decks, porches, carports and fences. These features can often be very vulnerable to convective heat exposures. Box in the undersides of the overhangs, decks and balconies with noncombustible or fire-resistant materials.

Any other structures attached to the house, such as decks, porches, fences, and outbuildings should be considered part of the house. These structures can act as fuel bridges, particularly if constructed from flammable materials. Therefore, if you wish to attach an all-wood fence to your structure, use masonry or metal as a protective barrier between the fence and structure. Use metal when constructing a trellis and cover it with high-moisture, low flammability vegetation. Screen or box-in areas below patios and decks with wire screen no larger than 1/8 inch mesh. Consider a terrace instead of a deck if located at the top of a hill in direct line of a fire moving up slope.

"504.11 Detached accessory structures. Detached accessory structures located less than 50 feet (15 240 mm) from a building containing habitable space shall have exterior walls constructed with materials approved for a minimum of 1-hour fire-resistance-rated construction, heavy timber, log wall construction or constructed with approved noncombustible materials on the exterior side. When the detached structure is located and constructed so that the structure or any portion thereof projects over a descending slope surface greater than 10 percent, the area below the structure shall have all underfloor areas enclosed to within 6 inches (152 mm) of the ground, with exterior wall construction in accordance with Section 504.5 or underfloor protection in accordance with Section 504.6. Exception: The enclosure may be omitted where the underside of all exposed floors and all exposed structural columns, beams and supporting walls are protected as required for exterior 1-hour fire-resistance-rated construction or heavy timber construction." 2003 International Urban-Wildland Interface Code

"8.8 Accessory Structures. Outbuildings, patio covers, gazebos, and other accessory structures shall be constructed to meet the requirements of this chapter or shall be separated from the main structure by a minimum of 9.14 m (30 ft)." NFPA 1144, Standard for Protection of Life and Property from Wildfire, 2002 Edition

WALLS & SIDING

Exterior walls are most affected by wildfire's radiant and convective heat, and by the direct impingement of the fire. It is recommended to use a *minimum* of a *Class III Flame-Spread-Rated* siding material. The most widely accepted flame-spread classification system appears in the *National Fire Protection Association Life Safety Code, NFPA No. 101*. The *Fire Resistance Directory*, published by the Underwriters Laboratory, lists many examples of accomplishing one-hour fire-resistant exterior wall construction.

Although a fire on an exterior wall may not penetrate inside the structure, the fire can 'bridge' to other vulnerable areas such as eaves, soffits, vents and windows. Wall materials that resist heat and flames include cement, plaster, stucco and concrete masonry such as stone, brick or block. Though some materials may not burn, such as vinyl, they may lose their integrity when exposed to high temperature and fall away or melt, providing the fire with a direct path inside the home.

Wood Panels and Boards.

Wood panels and boards are the most common and economical forms of siding, but they are very combustible. This siding is usually about 1/2 inch to 3/4 inch thick, and can burn through to the structure behind it in less than 10 minutes. A one-hour rating *can* be achieved by adding gypsum sheathing behind the siding. However, this addition has limited value because the siding can still ignite, and the fire can spread to other parts of the building such as the eaves, windows and roof above the exterior wall.

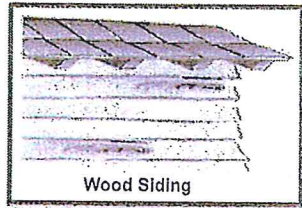

Fiber Cement Panels, Boards and Shingles

These products are noncombustible, but they may not be rated and may need gypsum sheathing to achieve a one-hour rating. They are very economical and cost just a little more than wood products. When these products are applied with gypsum sheathing they offer the most economical

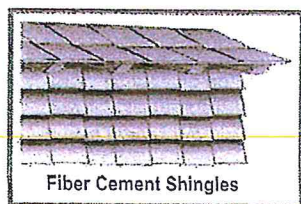

way to side a house that will resist almost all fire hazard conditions. They are virtually permanent on a vertical surface, and usually have a 50 year guarantee. Some need to be painted and some can take a stain with satisfactory results. They are also available with textures molded to imitate wood grain.

Metal: Galvanized Steel, Aluminum, Boards, Panels and Shingles

Like their counterparts in roofing, these products are available in either flat sheets with seams, a stamped board or shingle that imitates a wood product. They are factory painted with two-part epoxy paint and usually have a 50 year guarantee.

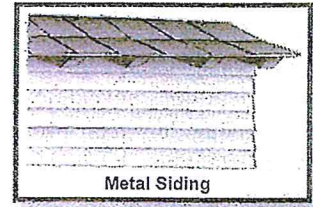

Unlike the fiber cement product, the paint on this product is usually a part of the guarantee; making it is an almost permanent, non-maintenance material. It is noncombustible, but like other metal products, it needs a gypsum sheathing to achieve a one-hour rating.

Heavy Timber or Log Construction

This wood product has a minimum thickness of 6 inches for frame members and exterior siding, and 3 inches for decking and steps. Heavy timber is recognized by building codes as a separate fire-resistive category.



Even though heavy timber is combustible, the low surface-to-volume ratio causes it to burn very slowly. This makes it applicable for medium and high fire risk situations.

"Real" Stucco

Real stucco, as base material, is 3/4 inch to 1 inch thick cement and gypsum. The stucco is applied in two or three coats with metal mesh reinforcing. If the color is integrated into the final coat it lasts a very long time. Guarantees are usually 10 to 20 years. It is both a non-combustible and one-hour rated material, which makes it a very good material for high hazard areas. However, Real Stucco tends to be expensive and is also prone to cracking if not applied absolutely correctly.

STRUCTURE DESIGN

Synthetic Stucco:

Exterior Insulating Finish System (EIFS)

This product is a 1/8 inch thick acrylic cement finish on fiberglass mesh. It is applied to the top surface of 1 to 2 inches of expanded polystyrene (EPS). The color, like real stucco, is in the cement coat and is long lasting. This is the preferred stucco method because it takes less labor and is less expensive. The foam insulation isolates the stucco finish from the building, which virtually eliminates cracking.

The surface is noncombustible and has no rating by itself. This product significantly delays a fire due to the insulation quality of the rigid foam and the fact that the system does not ignite; it will fail and fall away. This product has application in moderate to high fire hazard situations. It can obtain a one-hour rating with gypsum sheathing.

Concrete Synthetic Stone

These products are cast concrete with integral color, forming the texture and shape of the stone being imitated. They are modular shapes that have consistent dimensions with flat backs, which will reduce installation labor costs. Synthetic stone is reinforced with fiberglass and steel mesh making it very resistant to cracking. It is fully noncombustible and is usually rated as a one-hour material.

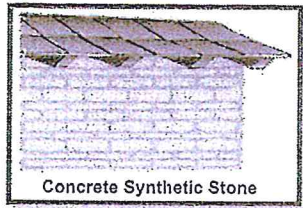

Brick, Stone and Block

These materials are both permanent and fireproof. Ratings are usually two hours. These are the best products to use in regard to fire resistivity but are the most expensive and may require additional reinforced structural support.

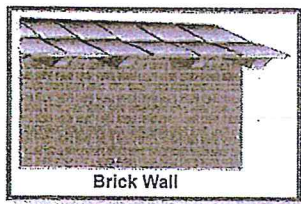

Material Classification Examples

Class A (2-4 hours) & Class B (1-hour)

Heavy timber log (minimum of 6 inch diameter), Brick, Stone, Block, Concrete synthetic stone, Gypsum

sheathing, Metal, Stucco, Synthetic stucco, Fiber cement panels, boards & shingles.

Class C (20-min.)

Wood panels and boards

"8.5 Exterior Vertical Walls. Exterior vertical walls shall be constructed of heavy timber, as defined by local building standards, or by a 20-minute fire-resistive-rated assembly on exterior walls potentially exposed to a wildland fire unless the wildland fire risk and hazard severity assessment requires greater protection." NFPA 1144, Standard for Protection of Life and Property from Wildfire, 2002 Edition

"504.5 Exterior walls. Exterior walls of buildings or structures shall be constructed with materials approved for a minimum of 1-hour fire-resistance-rated construction on the exterior side or constructed with approved noncombustible materials. Exception: Heavy timber or log wall construction. Such material shall extend from the top of the foundation to the underside of the roof sheathing." 2003 International Urban-Wildland Interface Code

FIREPLACE CHIMNEYS

Windblown embers can access the structure through the fireplace's chimney flue. Once inside, the firebrands can collect on flammable objects greatly increasing the chance of combustion. The situation can also be reversed: embers from the fireplace fire could fly out the chimney and start a fire on the structure roof or adjacent to the structure. To avoid this situation,

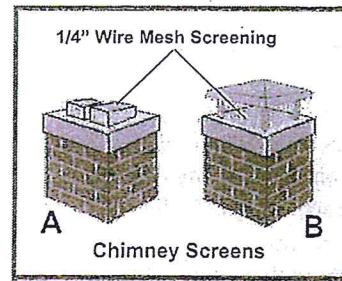

install a spark arrestor on the chimney or flue opening, made from welded wire or woven wire mesh with openings less than 1/4" wide. Installation B is better than A, because the horizontal screen mesh in A will burn-out and disintegrate from the fireplace heat after time, and must be inspected and replaced periodically.

"8.7 Chimneys and Flues. 8.7.1 Outlet Screen. Every fireplace and wood stove chimney and flue shall be provided with an approved spark arrestor constructed of a minimum 12-gauge welded wire or woven wire mesh, with the openings not to exceed 12.7 mm (1/2 inch)." NFPA 1144, Standard for Protection of Life and Property from Wildfire, 2002 Edition

OTHER DESIGN CONSIDERATIONS

SMOKE DETECTORS

Smoke detectors have saved many lives, and may save yours. More than 50 percent of fatal residential fires take place at night when people are sleeping. If a fire starts while your family is asleep, smoke detectors will wake you up. They can make the difference between life and death in a fire emergency.

Position smoke detectors on the ceiling just outside each bedroom. If you have a multi-level home, install a detector on every level. If you sleep with your bedroom door closed, place an additional detector inside your bedroom.

Before you buy a smoke detector, make sure it is listed and approved by an independent testing laboratory and the State Fire Marshal. Read the instructions enclosed with your smoke detector carefully to find out exactly how and where to install it. Be sure to test the smoke detector each month and change its batteries at least once a year. Smoke detectors with battery back-up or electrical back-up are highly recommended.

WATER SUPPLY

Water supply is an extremely important element to be considered during the construction design process. All potential water needs for the structure should be incorporated, especially for fire fighting. Local building codes and the fire marshal should be consulted for more information.

"7.1 - Minimum Water Supply Requirements

7.1.1 At a minimum, every building shall be provided with a water supply meeting the requirements of NFPA 1142, Standard on Water Supplies for Suburban and Rural Fire Fighting, for the purpose of fire fighting." NFPA 1144, Standard for Protection of Life and Property from Wildfire, 2002 Edition

"SECTION 404 WATER SUPPLY

404.1 General. When provided in order to qualify as a conforming water supply for the purpose of Table 503.1 or as required for new subdivisions in accordance with Section 402.1.2, an approved water source shall have an adequate water supply for the use of the fire protection service to protect buildings and structures from exterior fire sources or to suppress structure fires within the urban-wildland interface area of the jurisdiction in accordance with this section." 2003 International Urban-Wildland Interface Code

HOME SPRINKLER SYSTEMS

Home sprinkler systems are one of the most reliable and effective forms of protection from fire because they provide an immediate response to extinguish a fire inside your home. They also can extinguish a fire when you are asleep or when you are away. Sprinkler systems may require an independent water supply in some areas. Consult the local building codes, fire marshal and fire protection requirements for further information.

Self-contained home fire protection systems are available that are similar to those in commercial buildings (hotels, office buildings, etc.), but are compact and aesthetically designed. A cabinet, installed in the wall, usually contains a fire extinguisher and 70 to 140 feet of flat fire hose, connected directly to the home water system. Some are equipped with an independent high pressure pump. One of several typical products that are available is illustrated here.

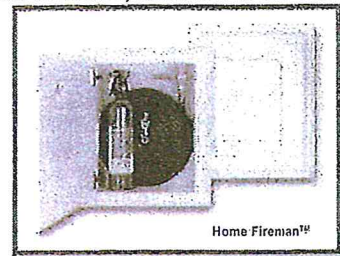

"SECTION 602 - AUTOMATIC FIRE SPRINKLER SYSTEMS. An approved automatic fire sprinkler system shall be installed in all occupancies in new buildings required to meet the requirements for Class 1 ignition-resistant construction in Chapter 5. The installation of the automatic fire sprinkler systems shall be in accordance with nationally recognized standards." 2003 International Urban-Wildland Interface Code

FIRE PROTECTION DURING CONSTRUCTION

Another important consideration to be included in the construction planning process is to ensure adequate fire protection is provided during the actual construction. Again, local building, construction and fire marshal requirements should be consulted.

"9.1 General Requirements. The provisions of NFPA 241, Standard for Safeguarding Construction, Alteration, and Demolition Operations shall apply in addition to the specific requirements of this section." NFPA 1144, Standard for Protection of Life and Property from Wildfire, 2002 Edition

PLANTS FOR A FIREWISE LANDSCAPE *

FLOWERS & GROWDCOVERS

Scientific Name	Common Name
<i>Achillea lanulosa</i>	Native yarrow
<i>Aconitum columbianum</i>	Columbian monkshood
<i>Allium cernum</i>	Nodding onion
<i>Allium geyeri</i>	Geyer onion
<i>Anaphalis margaritacea</i>	Pearly everlasting
<i>Antennaria parvifolia</i>	Small-leaf pussytoes
<i>Antennaria rosea</i>	Rosy pussytoes
<i>Aquilegia</i> spp.	Columbine
<i>Aquilegia coerulea</i>	Colorado blue columbine
<i>Arabis</i> sp.	Rockcress
<i>Artemesia frigida</i>	Fringed sage
<i>Artemesia ludoviciana</i>	Prairie sage
<i>Aster leavis</i>	Smoot aster
<i>Aster porteri</i>	Porter aster
<i>Calochortus gunnisonii</i>	Mariposa lily
<i>Campanula rotundifolia</i>	Common harebell
<i>Claytonia lanceolata</i>	Spring beauty
<i>Delphinium</i> spp.	Delphinium
<i>Dianthus</i> spp.	Pinks
<i>Epilobium angustifolium</i>	Fireweed
<i>Erigeron flagellarius</i>	Whiplash dairy, trailing fleabane
<i>Eriogonum umbellatum</i>	Sulphur flower
<i>Erysimum asperum</i>	Western wallflower
<i>Gaillardia aristata</i>	Blanket flower
<i>Galium boreale</i>	Northern bedstraw
<i>Geranium</i> spp.	Hardy geraniums
<i>Geum triflorum</i>	Prairie smoke
<i>Helianthella quinquenervis</i>	Aspen sunflower
<i>Helianthus pumilus</i>	Small sunflower
<i>Heuchera</i> spp.	Coral bells
<i>Ipomopsis aggregata</i>	Scarlet gilia
<i>Iris missouriensis</i>	Native iris
<i>Leucocrinum montanum</i>	Sand lily
<i>Liatis punctata</i>	Dotted gayfeather
<i>Linum lewisii</i>	Wild blue flax
<i>Lupinus argenteus</i>	Silver lupine
<i>Martensia lanceolata</i>	Narrow-leaved chiming bells
<i>Mimulus guttatus</i>	Yellow monkey-flower
<i>Monarda fistulosa</i>	Native beebalm
<i>Oenothera caespitosa</i>	White stemless evening primrose
<i>Penstemon caespitosus</i>	Mat penstemon
<i>Penstemon secundiflorus</i>	Sidebells
<i>Penstemon virens</i>	Blue mist penstemon
<i>Polemonium</i>	Jacobs ladder
<i>Potentilla fissa</i>	Leafy potentilla
<i>Ratibida columnifera</i>	Prairie coneflower
<i>Rudbeckia hirta</i>	Black-eyed Susan
<i>Scutellaria brittonii</i>	Skullcap
<i>Sedum</i> spp.	Stoncrop
<i>Sedum lanceolatum</i>	Yellow stoncrop
<i>Senecio spartioides</i>	Broom groundsel
<i>Solidago missouriensis</i>	Smooth goldenrod
<i>Thalictrum fendleri</i>	Fendler meadowrue
<i>Thermopsis divaricarpa</i>	Spring golden banner
<i>Tradescantia occidentalis</i>	Western spiderwort

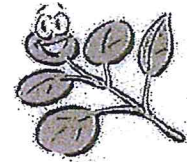

PLANTS FOR A FIREWISE LANDSCAPE *

SHRUBS

Scientific Name

Arctostaphylos uva-ursi
Betula ganulosa
Ceanothus fendleri
Cercocarpus intricatus
Cercocarpus montanus
Chrysothamnus spp.
Cornus stolonifera
Holodiscus dumosus
Jamesia americana
Mahonia repens
Philadelphus microphyllus
Psycocarpus monogynus
Prunus besseyi
Purshia tridentata
Ribes aureum
Rhus sp.
Rosa woodsii
Shepardia canadensis
Symphoricarpos spp.
Viburnum edule
Yucca glauca

Common Name

Kinnikinnick, bearberry
Bog birch
Buckbrush, mountain lilac
Little-leaf mountain mahogany
True mountain mahogany
Rabbitbrush
Redwig dogwood
Ocean spray, cliff/rock spirea
Wax flower
Creeping grape holly
Little-leaf mockorange
Mountain ninebark
Western sand cherry
Antelope bitterbrush
Golden currant
Sumac
Woods or native wild rose
Russet buffaloberry
Snowberry, coralberry
Highbush cranberry
Spanish bayonet, small soapweek,
Great plains yucca



LARGE SHRUBS AND TREES

Scientific Name

Acer ginnala
Acer glabrum
Acer grandidentatum
Acer tataricum
Alnus tenuifolia
Amelanchier alnifolia
Amelanchier utahensis
Betula nigra
Betula occidentalis
Cercocarpus ledifolius
Corylus cornuta
Crataegus spp.
Fraxinus pennsylvanica
Gleditsia triacanthos
Malus ssp.
Populus angustifolia
Populus tremuloides
Prunus americana
Prunus pennsylvanica
Prunus virginiana melanocarpa
Rubus delisiosus
Salix amygdaloides
Shepherdia argentea
Sorbus scopulina

Common Name

Amur maple, Ginnala maple
Rocky Mountain maple
Wasatch maple, Canyon maple
Tatarian maple
Thinleaf alder
Saskatoon alder-leaf serviceberry
Utah serviceberry
River birch
Western water birch
Mountain mahogany
Filbert, beaked hazelnut
Hawthorn (several native)
Green ash
Honeylocust
Crabapple
Narrowleaf cottonwood
Aspen
American wild plum
Pine/fire/wild red cherry
Western chokecherry
Boulder raspberry, thimbleberry
Peachleaf willow
Silver buffaloberry
Western mountain ash

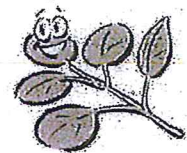

* Some plants, shrubs and trees will not grow at higher elevations.

Check with your State Forestry Office or Master Gardener before planting.



CLOSING COMMENTS

Congratulations, you made it to the end of your personalized report. I sincerely hope you found the information that I presented in this report, thought provoking and useful in your efforts to make your home as fire safe as possible. We will never make our homes absolutely fire proof. But with a little effort and determination we can move towards that idea. We have the pleasure to live in one of the most beautiful areas in Oregon. But along with that comes some responsibility to prepare ourselves for the chances of wildfire. Together as a community we can meet those responsibilities. And together as a community we can win the battle the day wildfire comes to Wallowa County. Thank you for your commitment to this challenge.

Regards

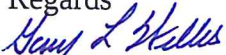
Gary L. Willis

DEFENSIBLE SPACE GUIDELINES

Defensible space refers to a minimum 30-foot area around houses and other buildings where vegetation has been significantly reduced or removed. The purpose of creating defensible space is to reduce the risk of losing homes and other property improvements to a wildfire.

HOW TO CREATE DEFENSIBLE SPACE

STEP 1 DETERMINE DEFENSIBLE SPACE DISTANCE. Use the table below to determine the minimum distance for defensible space, dependent upon slope and native vegetation type surrounding homes.

Standard Defensible Space Guidelines

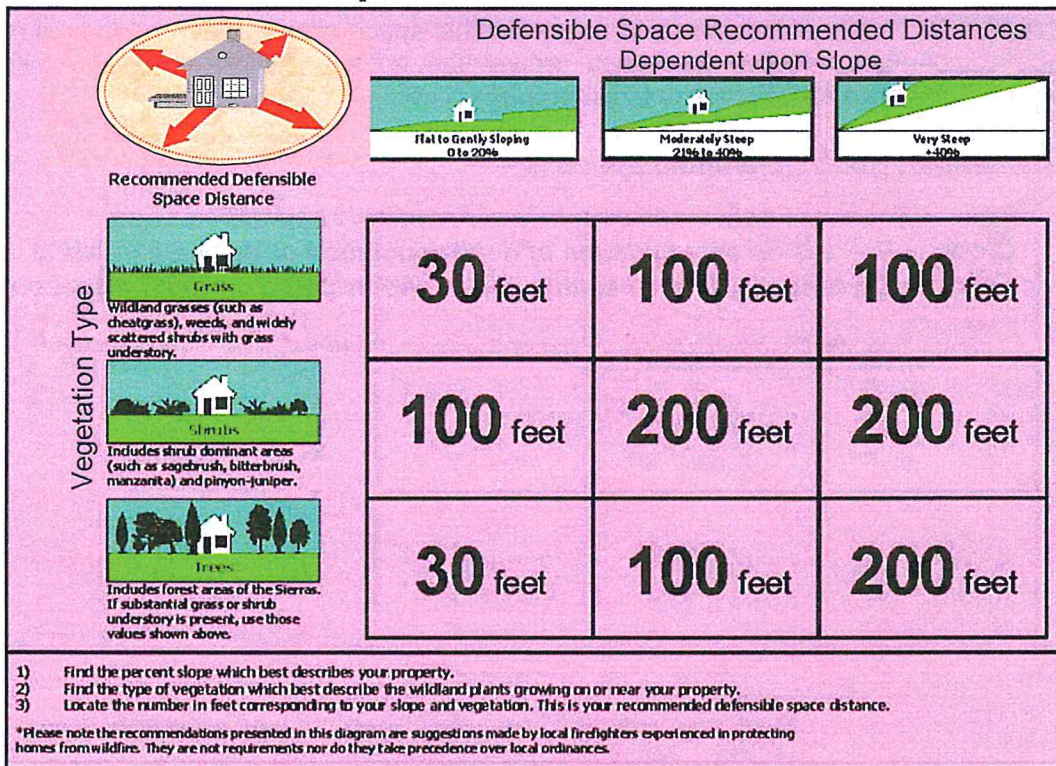

STEP 2 REMOVE. Cut and remove all dead, diseased or dying trees and shrubs from within the defensible space area. Remove selected trees and shrubs to eliminate continuous fuels extending up to the house. Also remove any flammable debris and firewood piles from within the minimum defensible space distance. Weeds or other dry vegetation should be removed from underneath porches and decks. Eliminate any flammable vegetation or debris within 10 feet of propane tanks. Remove leaves and debris from rain gutters.

- STEP 3 REDUCE.** Reduce vegetation height of shrubs under mature trees to decrease “ladder” fuels. Prune low tree branches to a minimum height of 4 feet and prune branches within 15 feet of structures and chimneys. Reduce accumulations of annual grasses (cheatgrass) through mowing or pre-emergent selective herbicide treatments in the fall. Reduce the accumulation of vegetation around wood fences through mowing or plant removal.
- STEP 4 REPLACE.** Substitute flammable vegetation such as juniper, sagebrush, and rabbitbrush with fire resistant plants. Replacement plantings may include low stature shrubs, decorative rock, lawn, flowerbeds, and succulent vegetation. Irrigation of vegetation throughout the fire season will decrease plant flammability.
- STEP 5 DISPOSE.** It is essential that all tree branches, shrubs, and other plant biomass be removed from the site immediately to a safe disposal area. This material dries rapidly and can contribute to the fire hazard problem if allowed to remain on the premises.
- STEP 6 MAINTAIN.** Maintenance of the defensible space area requires an annual review of fuel reduction guidelines around the home. Action should be taken to maintain an effective defensible space area.

Remember, good defensible space is –

Lean – There are only small amounts of flammable vegetation

Clean – There is no accumulation of dead vegetation or flammable debris

Green – Existing plants are healthy, green, and irrigated during fire season

(Source: Living With Fire...In the Big Sagebrush/Bitterbrush Environment. Nevada State Bureau of Land Management.
Produced by Ed Smith and JoAnne Skelly.)

Defensible Space

Wildland Fuels Reduction Maintenance: WHAT AND WHERE

For more information visit <http://firewise.org>

Outer defensible space: This area extends from the 30 foot "Lean, Clean and Green" area out to at least 100 feet, and up to 200 feet on steeper slopes with thicker vegetation. It usually lies beyond the residential landscape and often consists of naturally occurring plants, such as conifer and hardwood trees, brush, weeds, and grass.

Routine maintenance tasks in this zone:

- Remove dead vegetation, including dead shrubs, fallen branches, thick accumulations of needles and leaves, etc.
- Before fire season, mow grass to 4 inches or less in height.
- Thin out dense patches of trees and shrubs to create separation between them in order to slow the spread of fire.
- Reduce ladder fuels by removing low tree branches and shrubs growing directly under trees.
- Remove invasive weeds such as blackberries and Scotch broom.

Noncombustible Area: Create a Noncombustible Area at least 5 feet wide around the base of your home. This area needs to have a very low potential for ignition from flying embers. Use sufficiently watered, herbaceous plants such as lawn, ground cover, and flowers; that are recommended for southwest Oregon; rock mulches; or hard surfaces, such as brick and pavers, in this area. Keep this area free of woodpiles, wood mulches and flammable shrubs such as juniper.

Routine maintenance tasks in this zone:

- Remove any dead plant material that has accumulated such as leaves, needles, and twigs.
- Keep gutters and roofs cleaned of debris.
- Make sure any overhanging limbs are trimmed back at least 10 feet or more from the roof.

Lean, Clean, and Green Area: The portion of your property at least 30 feet from the home, should be a Lean, Clean, and Green area. Lean means that fire-prone, flammable vegetation is discouraged within 30 feet of the house, and any vegetation is maintained at a low density. Clean means there is no accumulation of dead vegetation or flammable debris within the area. Green denotes that plants located within this area are kept healthy, green, and sufficiently watered during fire season. For most homeowners, the "Lean, Clean, and Green Area" is the residential landscape. This area often has irrigation, contains ornamental plants, and is routinely maintained.

Routine maintenance tasks in this zone:

- Trim back fire-resistant shrubs annually.
- Limb up mature trees to at least 10 feet.
- Remove dead plant material such as leaves, needles, and twigs.
- Replace flammable plants with fire-resistant plants.
- Keep grass watered (green) and mowed to 4 inches.

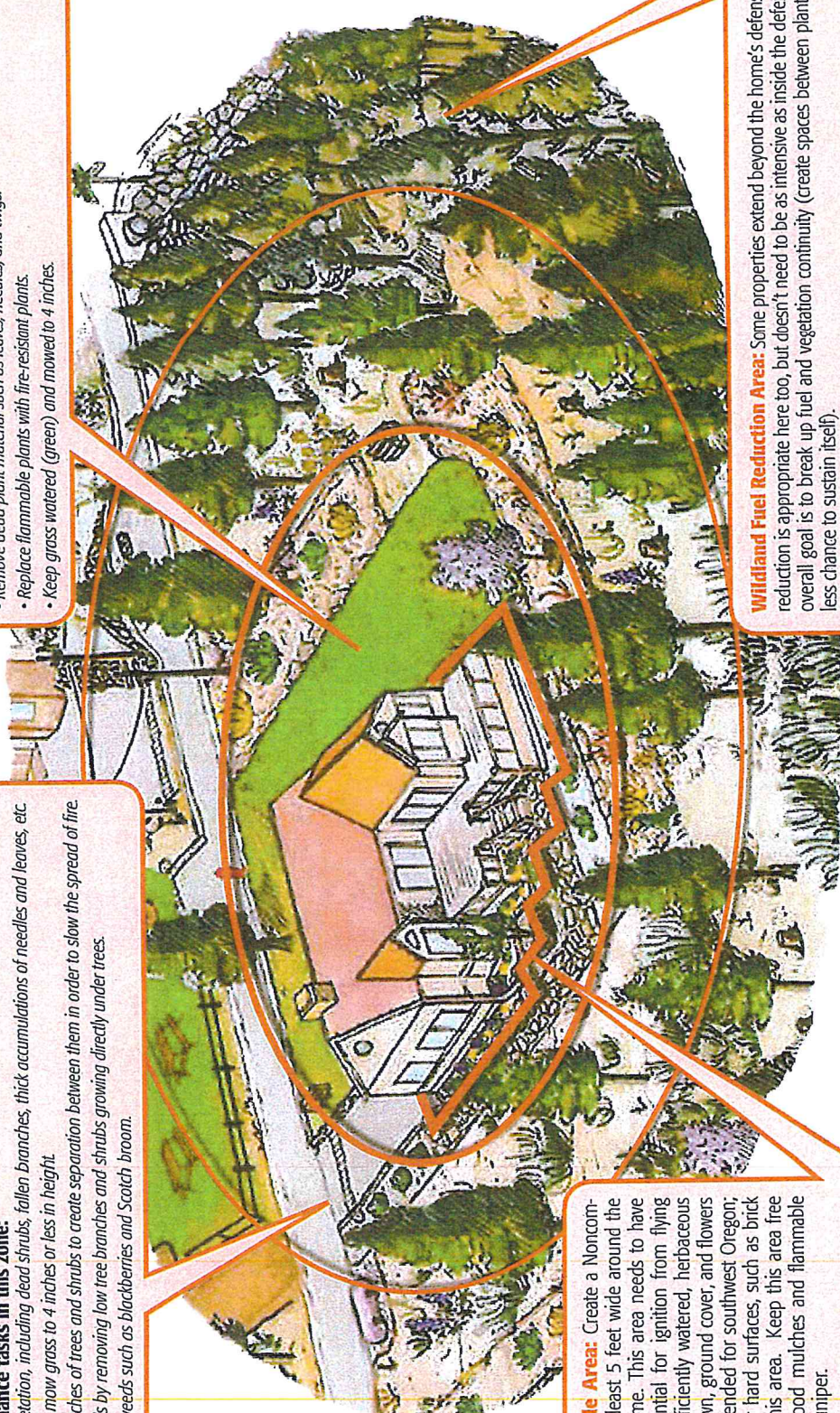

Wildland Fuel Reduction Area: Some properties extend beyond the home's defensible space. Fuels reduction is appropriate here too, but doesn't need to be as intensive as inside the defensible space. The overall goal is to break up fuel and vegetation continuity (create spaces between plants so that fire has less chance to sustain itself).

Routine maintenance tasks in this zone:

- Thin out dense patches of trees and shrubs to create separation between them.
- Reduce heavy accumulations of woody material (dead branches and twigs, slash, etc.)
- It's acceptable to leave some brush patches, downed logs, and dead trees for habitat and soil benefits OUTSIDE of your defensible space.