

# Main Street Design Guidelines

Gloucester, Virginia





# Main Street Design Guidelines

Gloucester, Virginia



For:

Gloucester Main Street Association  
Main Street Preservation Trust  
Cook Foundation and  
Gloucester County

Prepared By:



# Acknowledgements

## Design Committee

**Elizabeth Blackney**

*Executive Director, The Cook Foundation*

**Dave Brown**

*Co-Director, Fairfield Foundation*

**Jennifer Crittenden**

*Senior Vice President, Retail Alliance*

**Jennifer Dutton Haggerty**

*Executive Director, Gloucester Main Street Association*

**David Hudson**

*Financial Advisor*

**Dr. Adrienne Ryder Cook Joseph**

*Chair, Main Street Preservation Trust*

**Richard M. Wiatt Jr.**

*PLA*

## Main Street Preservation Trust Board

**Dr. Adrienne Ryder Cook Joseph,**

*Chair and Founder*

**Kim Hensley,**

*Vice-Chair*

**Dr. David Brown,**

*Secretary*

**David Hudson**

*Treasurer*

**Christina Cahill**

**Jenny Crittenden,**

**Debra Goodier**

**Cindy Jenkins**

**Dave S. Keel**

**Eugene Thompson**

**The Honorable Aubrey Layne**

**John Milner**

**Eugene Thompson**

**David Roddy**

**Diana West,**

*Executive Director*



Copyright © 2022 Frazier Associates, Main Street Preservation Trust, Gloucester Main Street Association, and Gloucester County. All rights reserved. No part of this book, including text, photographs, illustrations, cover design, and icons, may be reproduced or transmitted in any form, by any means (electronic, photocopying, recording, or otherwise) without the prior written permission of the publishers. This document may be reproduced in whole or part for use in matters related to the Gloucester Village Main Street Guidelines Project without prior written permission.

# Contents

- I. INTRODUCTION ..... 1
  - A. Context ..... 3
    - 1. Historic Context .....3
    - 2. Foundation for These Guidelines .....4
    - 3. Using These Guidelines.....5
  - B. Evaluating Your Property and Your Project ..... 6
    - 1. How to Approach Your Facade Improvement Project .....6
    - 2. Significance .....7
    - 3. Integrity and Alterations.....8
    - 4. Project Approach.....9
    - 5. Basis for the Guidelines .....10
  - C. Design Review Process..... 11
- II. COMMUNITY OVERVIEW.....13
  - A. Character of the Main Street Area ..... 15
  - B. Architectural Styles and Building Forms ..... 16
    - 1. Traditional Main Street Mercantile Form .....16
    - 2. Traditional Non-Mercantile Form .....17
    - 3. Residential Building Form.....18
    - 4. Auto-Oriented Building Form.....19

# Contents

- III. GUIDELINES FOR SITE ELEMENTS ..... 21
  - A. Introduction ..... 23
  - B. Front Setback Zone ..... 24
  - C. Walkways and Paths ..... 26
  - D. Parking Areas ..... 27
  - E. Plantings and Trees ..... 28
  - F. Fences and Walls ..... 30
  - G. Lighting ..... 32
  - H. Mechanical and Utilities Screening ..... 34
  - I. Accessibility ..... 35
  
- IV. GUIDELINES FOR EXISTING STRUCTURES — ELEMENTS ..... 37
  - A. Introduction ..... 39
  - B. Storefronts and Doors ..... 40
  - C. Windows and Shutters ..... 43
  - D. Cornices, Overhangs and Parapets ..... 48
  - E. Roof ..... 49
  - F. Rears of Buildings ..... 52

# Contents

- V. GUIDELINES FOR MATERIALS ..... 53
  - A. Introduction ..... 55
  - B. Wood ..... 56
  - C. Masonry ..... 58
  - D. Stucco ..... 62
  - E. Metal ..... 63
  - F. Glass ..... 64
  - G. Substitute Materials ..... 65
  - H. Paint and Color ..... 66
  
- VI. SIGNS ..... 69
  - A. Introduction ..... 71
  - B. Sign Types and Placement: On-Structure Signs ..... 72
  - C. Sign Types and Placement: Other Signs ..... 77
  - D. Number of Permanent Signs ..... 79
  - E. Graphic Design, Compatibility, and Execution ..... 79
  - F. Shape, Color, Materials, and Lighting ..... 80
  - G. Multi-Tenant Buildings ..... 82
  - H. Other Signs ..... 82
  - I. Sign Maintenance ..... 82

# Contents

---

- VII. AWNINGS & CANOPIES..... 83
  - A. Introduction ..... 85
  - B. Types ..... 86
  - C. Design and Placement ..... 87
  - D. Materials, Color and Lighting ..... 87
  
- APPENDICES ..... 89
  - A. References and Resources ..... 91
  - B. Glossary..... 95
  - C. Maintenance Checklist ..... 97
  - D. The Economic Impact of Building Improvements ..... 99



# Main Street Design Guidelines

Gloucester, Virginia

## INTRODUCTION I.





## A. Context

### 1. Historic Context:

Gloucester is the courthouse village for Gloucester County, one of Tidewater Virginia's earliest settlements. Named for Henry, Duke of Gloucester, third son of Charles I, Gloucester County figured prominently in the history of the colony and the Commonwealth of Virginia. It was here that Chief Powhatan's daughter, Pocahontas, saved Captain John Smith from a tragic death at the hands of the Indians according to his writings and thus entered the pages of Virginia's history.

Gloucester County was formed from York County in 1651 and consisted of four parishes: Abingdon, Kingston, Petsworth and Ware. The original courthouse was constructed in the central part of the county shortly thereafter. Besides a tavern and store, there was little development around the courthouse complex until the turn of the twentieth century when a bank building was constructed. Other retail establishments followed, and a small village grew around the courthouse area throughout the rest the century.

Within the past several decades, growth from the nearby Hampton Roads area has reached Gloucester County, and numerous new developments have appeared on former rural waterfront land and farms. New commercial development has grown along U. S. Route 17, the major north/south corridor of the county. Gloucester village has continued to grow, and physical improvements have been undertaken in the Main Street area.



Looking West on Main Street, this postcard view shows the C.S. Smith Office and the Tucker Store.



The establishment of the Bank of Gloucester ushered in a new era in the development of Gloucester and an increased scale for buildings on Main Street.



This undated postcard view shows the business section of Gloucester looking towards the Courthouse.

## A. Context, continued

### 2. Foundation for These Guidelines:

The extensive growth of Gloucester County and the surrounding region over the past several decades has resulted in growing concern over the long-term impact on the village character. It was in this context of concern for the future that the Main Street Preservation Trust (MSPT), a local foundation, was created by the late Edwin Joseph. His vision to create a trust to enhance Main Street is an important gift that will result in far reaching and positive economic benefits for the entire community.

To convert Mr. Joseph's vision into a plan, the Main Street Preservation Trust decided to request outside expert consultants to advise the MSPT how best to direct their resources on Main Street to the greatest advantage of the citizens of Gloucester. In addition, Gloucester County was also interested in obtaining outside expert advice in preparation of a Comprehensive Plan for the Village. Both parties decided to contribute funds to retain the services of Frazier Associates and Arnett Muldrow & Associates as consultants for this purpose, and the Gloucester Courthouse Village Plan was completed in 2009 and adopted by the County as part of their Comprehensive Plan. The Plan outlined a series of key projects and strategies for the revitalization of the Route 17 Business Corridor and Main Street through a broad and inclusive community process.

As part of the Gloucester Village Plan, Main Street was divided into sub-areas. The traditional commercial core, east of Courthouse Square, was named the Traditional Main Street Sub-Area and is the focus of these guidelines.

The recommendations of the Village Plan included the creation of a façade improvement program with a matching grant component. These guidelines have been developed as part of this recommendation and will serve as a guide for building owners who rehabilitate their buildings and sites, as well as a reference for the grant administration review committee (committee name to be finalized when process is finalized) that will be created. In addition, the expansion of the Gloucester Courthouse Historic District in the future could result in a historic overlay zoning, giving the County review authority over projects in the district. These guidelines will serve as the standard for design review if such an ordinance is adopted.

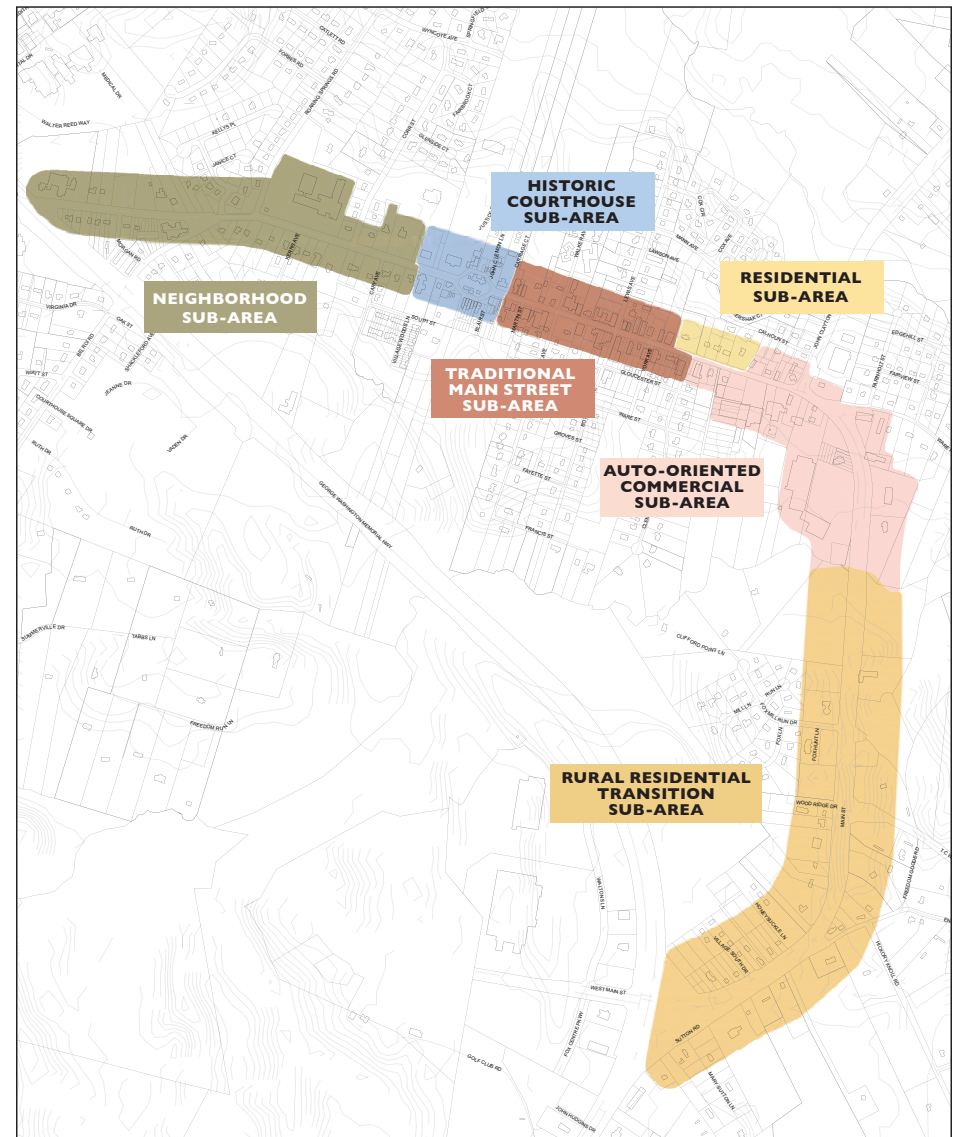

The Gloucester Courthouse Village Plan divided the village into sub-areas as shown on this map. The traditional commercial core, named the Traditional Main Street Sub-Area, is the subject of these guidelines.

### 3. Using These Guidelines:

The Gloucester Main Street Guidelines are organized into seven chapters. Illustrations and photographs provide examples of many of the items discussed. The first two chapters provide general information about the Village and the guidelines, and should be read before you begin your project. *Chapter 1: Introduction* outlines the purpose of these guidelines, the design review process, general background on the rehabilitation of historic structures, and the underlying basis for the guidelines. *Chapter 2: Overview* defines the character of the Main Street area and the typical building types and architectural styles found in the district.

The remaining chapters address specific elements and provide guidelines and maintenance information for each. *Chapter 3* covers site elements such as parking, landscaping, walks, and walls, and addresses accessibility issues. *Chapter 4* provides guidelines and maintenance information for existing building elements such as roofs, cornices, and storefronts. *Chapter 5* goes into more detail about the materials found in the district, with guidelines and maintenance information on each material. *Chapter 6* outlines guidelines for signs, and *Chapter 7* provides information on awnings.

The appendices provide helpful resources including a bibliography, a list of resource organizations, a glossary of terms and a building maintenance checklist.

Please note throughout this document that these guidelines are supplemental to the requirements for sites and buildings laid out in the zoning ordinance and the building code. Should historic district ordinances be adopted, it will be an overlay district and would/could have conflict with zoning and would require a higher standard.



Among the recommendations that came out of the Village Plan, streetscape improvements to enhance the safety of the pedestrian environment along Main Street played a large role. The photo-simulation on this page illustrates the impact of crosswalks and a change of materials at the median/turning lane.



## B. Evaluating Your Property and Your Project

### 1. How to Approach Your Facade Improvement Project

The appearance of a building in a Main Street commercial district can have a big impact on the viability of a business. While many other factors play a large part in the success of a Main Street business, appearance can help the visibility of a building and can help to attract customers. A facade improvement program that helps many merchants beautify their buildings can strengthen the entire Main Street.

Embarking on a facade improvement project can be a daunting task. Where do you begin? These guidelines are intended to help building owners make sense of their building, both its strengths and its problems, and outline a process for improving a building's appearance.

The approach to a building improvement project should begin by addressing basic maintenance issues, for instance, addressing peeling paint and leaking gutters. Next, repair the elements that are on the building: existing doors, windows, cornices, etc. Removing inappropriate elements that take away from the overall image of the building is the next priority, followed by rebuilding missing features, such as a cornice that has been removed. Finally, cosmetic improvements, such as highlighting architectural features through a new paint scheme, adding awnings, or replacing signs, should be undertaken as the final step.

These guidelines are organized in a similar way: begin with maintenance, then repair, remove, rebuild, and finally focus on cosmetic enhancements.



Early twentieth-century buildings on Main Street are a full two stories and are classically designed.

## 2. Significance

The preservation community recognizes different levels of significance for historic buildings and sites as identified through the Virginia Landmarks Register (VLR), National Register of Historic Places (NRHP), and National Historic Landmark (NHL) designation process.

The Virginia Landmarks Register (VLR) is the state's official list of properties and districts important to Virginia's history. By inclusion on this register, the state seeks to recognize and encourage the preservation of these important resources.

The National Register of Historic Places (NRHP) seeks to identify, evaluate and protect districts, sites, buildings, structures, and objects that are significant in American history, architecture, archeology, engineering, and culture. National Historic Landmarks are designated by the Secretary of the Interior because they possess exceptional value or quality in illustrating or interpreting the heritage of the United States.

Gloucester County currently has one district listed on the National Register of Historic Places, the Courthouse Square area, immediately adjacent to the Main Street area, as well as 22 individual properties throughout the County. The Gloucester Village Main Street area is eligible to become a separate historic district, and this process is currently underway. It is important to note, however, that listing on these registers does not provide any local protection or restrictions for the property or the district. The County's only regulatory authority comes from a local historic district zoning, which could be implemented once the National Register process is complete; one does not depend on the other. At that time, should the community desire, these guidelines can take on another purpose as the standard for the County's review of the historic district zoning.



Gloucester's Main Street area has many buildings that would potentially contribute to a historic district, such as the Bank of Gloucester building (above). All the buildings, while they may or may not qualify for contributing status, contribute to the character of the village.



## B. Evaluating Your Property and Your Project, continued

### 3. Integrity and Alterations

The physical character of a historic Main Street district comes from its location, design, setting, materials, workmanship, feeling, and association. Changes to a building may result in a loss of historic integrity to a structure, and when allowed on numerous structures, contribute to the loss of integrity of the district.

However, changes that were made to historic buildings after the original construction and more than fifty years ago may have achieved their own level of significance and generally should be preserved. It is also important to note that while not all the buildings in the Main Street area will be considered historic or contributing to a historic district, all the buildings along Main Street do contribute to the character of Gloucester's unique and intact downtown.



The Tri-County Furniture building provides an example of a potential facade rehabilitation. A historic photo (above left) shows the building as it was constructed in 1938, including the structural pigmented glass used to clad the storefront. Currently, the facade has fallen into disrepair (above). An illustration (left) shows how the facade can be rehabilitated. Solid panels that provide room for signage are placed where the original transom windows once were; glass or metal panels bring back the appearance of the structural pigmented glass; brick cleaning, glass repair, and sign restoration complete the project.



---

#### 4. Project Approach

Terms such as preservation, restoration, and rehabilitation are often used interchangeably; however, they mean different approaches to the work performed on a historic structure.

The treatments referred to in the following guidelines chapters are based on a rehabilitation approach.

##### **PRESERVATION**

Focuses on the maintenance and repair of existing historic materials and retention of a property's form as it has evolved over time.

##### **REHABILITATION**

Acknowledges the need to alter or add to a historic property to meet continuing or changing uses while retaining the property's historic character. This approach must not damage or destroy significant materials, features or finishes and requires that any changes be compatible with the building and its context.

##### **RESTORATION**

Depicts a property at a particular period of time in its history; retaining and restoring elements from that period while removing evidence of other periods.

##### **RECONSTRUCTION**

Re-creates vanished or non-surviving portions of a property for interpretive purposes.

##### **REMODELING**

Is the alteration of a structure in a way that may or may not be sensitive to the preservation of its significant architectural forms and features.

## B. Evaluating Your Property and Your Project, continued

### 5. Basis for the Guidelines

These guidelines are based on *The Secretary of the Interior's Standards for Rehabilitation*. First developed in 1979, the Secretary's Standards have been expanded and refined, most recently in 1995. They are used by the National Park Service to determine if the rehabilitation of a historic building has been undertaken in a manner that is sensitive to its historic integrity.

The guidelines are very broad by nature as they apply to the rehabilitation of any contributing building in any historic district in the United States.

*The Secretary Standards* and these guidelines express a basic rehabilitation credo of "retain, repair, replace." In other words, do not remove a historic element unless there is no other option, and do not replace an element if it can be repaired.

### THE SECRETARY OF THE INTERIOR'S STANDARDS FOR REHABILITATION ARE AS FOLLOWS:

1. A property will be used as it was historically or be given a new use that requires minimal change to its distinctive materials, features, spaces, and spatial relationships.
2. The historic character of a property will be retained and preserved. The removal of distinctive materials or alteration of features, spaces, and spatial relationships that characterize a property will be avoided.
3. Each property will be recognized as a physical record of its time, place, and use. Changes that create a false sense of historical development, such as adding conjectural features or elements from other historic properties, will not be undertaken.
4. Changes to a property that have acquired historic significance in their own right will be retained and preserved.
5. Distinctive materials, features, finishes, and construction techniques or examples of craftsmanship that characterize a property will be preserved.
6. Deteriorated historic features will be repaired rather than replaced. Where the severity of deterioration requires replacement of a distinctive feature, the new feature will match the old in design, color, texture, and, where possible, materials. Replacement of missing features will be substantiated by documentary and physical evidence.
7. Chemical or physical treatments, if appropriate, will be undertaken using the gentlest means possible. Treatments that cause damage to historic materials will not be used.
8. Archeological resources will be protected and preserved in place. If such resources must be disturbed, mitigation measures will be undertaken.
9. New additions, exterior alterations, or related new construction will not destroy historic materials, features, and spatial relationships that characterize the property. The new work will be differentiated from the old and will be compatible with the historic materials, features, size, scale and proportion, and massing to protect the integrity of the property and its environment.
10. New additions and adjacent or related new construction will be undertaken in such a manner that, if removed in the future, the essential form and integrity of the historic property and its environment would be unimpaired.

### C. Design Review Process

Upon the creation of a Facade Improvement Program, which will have a matching grant component, these guidelines will be utilized by the Design Committee, which will review the improvements a building owner would like to make and will determine which changes are eligible for grant funding.

The Design Committee is made up of representatives from the community, including business and property owners, as well as representatives from the Main Street Preservation Trust.

The application and review process is outlined in the flow chart at right; for more detailed information contact the Main Street Preservation Trust.

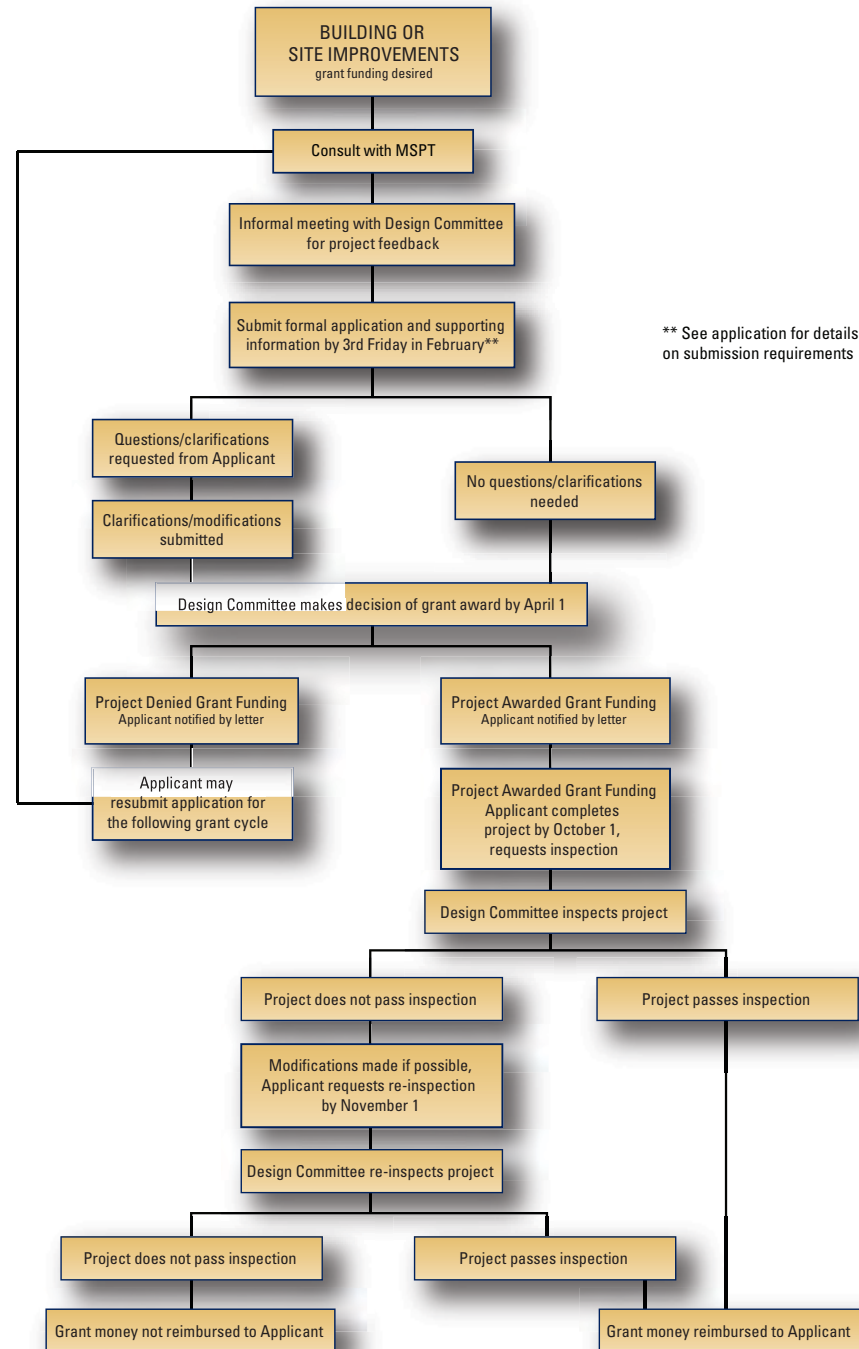



# MAIN STREET DESIGN GUIDELINES

GLOUCESTER, VIRGINIA

## COMMUNITY OVERVIEW II.





## A. Character of the Main Street Area

The traditional Main Street area of Gloucester Village extends eastward from the Courthouse Square toward the Route 14/Route 17 intersection. The character and scale are those of a traditional village – a mix of uses, a variety of building size, height, spacing and setbacks, and an eclectic collection of architectural styles create a unique and vibrant district. The variation of setbacks and spacing creates a sense of informality that is an important part of the unique village character. Building styles reflect two centuries of Gloucester’s history, with each generation leaving its imprint on the village in the form of diverse architectural styles and details.

These buildings sit in a context of recent streetscape improvements, including the addition of period lighting, exposed pebble-aggregate sidewalks, landscaping and special street identification signs. Landscape areas define on-street parking, and some private parking areas are found behind and beside buildings.



The variation of building size, setback, and style creates the unique village character that defines Gloucester’s Main Street.



A view of Main Street shows the character of the landscape as well as the buildings.



Recent streetscape improvements include period lighting, exposed aggregate and brick sidewalks, and street furniture.

## B. Architectural Styles and Building Forms

The building forms and architectural styles found throughout the village reflect two centuries of Gloucester's history. The styles range from early 1900s Classical Revival examples to simple early-to mid-twentieth century vernacular commercial buildings; from Art Deco structures to Colonial Revival buildings that are more residential in scale. Modern additions to Main Street's collection of buildings have recently added even more diversity in form and scale.

For the purpose of these guidelines, the buildings are grouped by form rather than style, as this impacts their relationship to their site and how they function in the district. The four main forms found in the Village are: the traditional Main Street mercantile form; the traditional non-mercantile form; the residential form converted to office or retail use; and the auto-oriented form.

### 1. Traditional Main Street Mercantile Form:

The majority of the retail buildings along Main Street have a traditional Main Street commercial building form. The most prominent feature of this type is the street level storefront with large display windows. It typically sits at the sidewalk, leaving little space for landscaping in front and directly engaging the pedestrian. Typically it has little side yard, sometimes none.

This form ranges in size from one to two stories and is found in many styles, including Art Deco, Moderne, early- to mid-twentieth century vernacular, and Classical Revival and late Victorian, as well as more modern examples.



The Traditional Main Street Mercantile Form is defined by the presence of a storefront and the lack of a setback; architectural styles and details vary greatly, as illustrated by these three examples.





The Bank of Gloucester is an example of the Traditional Non-Mercantile form.



Non-Mercantile Form buildings typically do not have a storefront and are more institutional in character.

## 2. Traditional Non-Mercantile Form:

Some of the earliest surviving buildings on Main Street date from the early 1900's, including the Bank of Gloucester, which provides a good Classical Revival example of this form. As a more formal building type, this form is often two stories with a gable front facing the street. These buildings do not have a storefront; they function as a commercial use but engage the street in a more institutional way.

This form is often Classical Revival in style, and the majority of these buildings feature a pedimented gable end and Classical detailing that may include large columns and a large Classical cornice with dentils or modillions.

## B. Architectural Styles and Building Forms, continued

### 3. Residential Building Forms:

A number of the buildings along Main Street have a residential building form. Some of these buildings have been converted to retail or office use from a residential building, while others have been built in this form to accommodate commercial uses. This type tends to have a larger setback from the sidewalk than the previous types discussed above, leaving space for some landscaping and sometimes a wall or fence. Buildings of this type are typically freestanding, leaving space for a driveway, parking, or side yard beside the building. Smaller windows provide limited display space; bay windows are a common feature on this type. Often this type has a gable roof parallel to the street adorned with dormer windows.

Stylistically this building type can fall into a range of categories, with Colonial Revival examples being most common.



This example of a residential building form is a former residence converted to a business use.



The gable parallel to the street in this example is a typical characteristic of the residential form.

#### 4. Auto-Oriented Building Form:

The final building form found along the Village Main Street is the auto-oriented form. Built to accommodate the car, these later additions to Main Street included service stations and retail and office buildings set back from the street to allow parking or a driveway in the front of the building. As Main Street progresses east from Courthouse Square and nears the intersection of Route 17 and Route 14, this type becomes more common.



Auto-oriented building forms are more common towards the east end of the Main Street area and sometimes include a porte cochere.



Auto-oriented buildings are often set back from the street to allow parking in the front of the building.



# Main Street Design Guidelines

Gloucester, Virginia

## GUIDELINES FOR SITE ELEMENTS III.





**A. Introduction**

Site design is a very important component in helping to define the village character of the Main Street area. Site design includes both natural elements such as plantings and manmade features like accessory structures and walkways.

In much of the Main Street area, the buildings cover most of the lot; and, therefore, provide limited opportunities for site improvements. Other buildings have some space between them that may be used as a parking area or driveway.

The setbacks of the buildings from the sidewalk vary; some buildings are at the sidewalk, leaving no room for site improvements in front of the building; others have a small amount of space for plantings, walkways, and sometimes a wall or a fence; in very few cases there is a substantial front yard. This variation from site to site is an important factor in the creation of the informal village character of Gloucester’s Main Street.



Site elements, including landscaping, paving, furniture, fences and walls, are an important component of the village character of the Main Street area.

## B. Front Setback Zone

Gloucester gets much of its village feel from the varied front setback along Main Street; this variation gives the district a sense of informality. While many of the traditionally mercantile buildings sit at the edge of the sidewalk, these buildings are interspersed with buildings that have a setback, which can vary from a few feet to more than 15 feet.

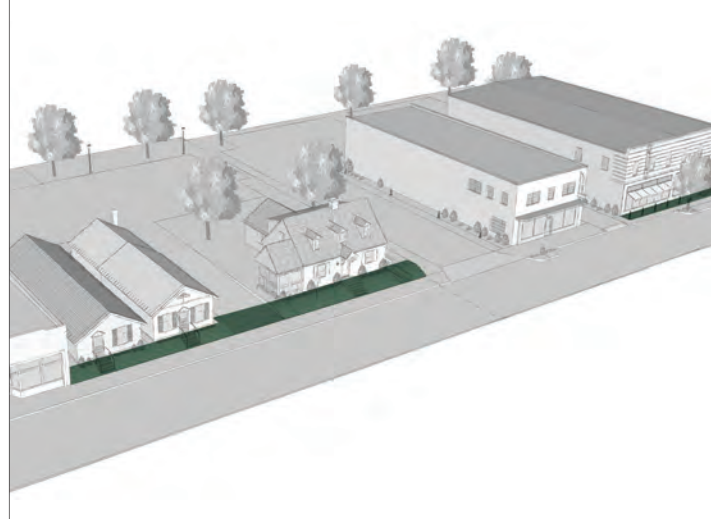

The setbacks along Main Street vary from building to building, allowing space for landscaping or paved areas in front of buildings on some sites.



A shallow setback from the sidewalk allows space for simple plantings.



Many traditional mercantile buildings have no setback.



Residential form buildings tend to have a deeper setback, which is often primarily landscaping with a narrow walk to the entrance. Here, a full-width porch extends into the setback zone.



This residential form building is set back further from the sidewalk than the neighboring mercantile form. This variation is one of the character-defining features of the Main Street area.



## GUIDELINES

- Retain existing front setback areas and their character-defining elements, such as walkways, plantings, walls, and bay windows.
- Appropriate uses for the front setback zone include plantings, signage, and possibly the addition of low walls, fences, paving, and site furniture.
- Refer to individual site elements below for specific guidelines on the elements contained within the front setback zone.



A common feature on many Gloucester Main Street buildings is the bay window, which extends into the front setback zone and provides a display area.



This row of buildings is set back enough to allow an outdoor seating area in front of the buildings, enclosed by a wall and planters. The setback zone also provides an ideal location for signage.



A paved setback area provides a location for outdoor seating.



The sidewalks throughout Gloucester are constructed of exposed aggregate concrete and brick; these materials are also appropriate for private walkways.



A private walkway blends with the sidewalk material and design.



Walkways and paths include access to front entrances as well as walks to access parking areas.



A brick walkway and steps lead to this storefront.

### C. Walkways and Paths

By the nature of the way Gloucester's buildings are sited on their lots, there is little room in most cases for walkways and paths. Buildings with shallow setbacks typically have a walkway leading to the front entrance; the most common materials for these walkways are exposed aggregate concrete and brick. These materials blend with the materials used in the public street improvements throughout the Village.

#### GUIDELINES

- Retain existing significant paving materials used in paths and walkways including brick and exposed aggregate concrete.
- Repair existing materials in kind by matching the materials and patterns of the existing paving.
- Ensure that new paving materials are compatible with the character of the area; brick and exposed aggregate concrete are the most appropriate materials in Gloucester.

## D. Parking Areas

On-street parking along Main Street is defined by landscaped areas and is supplemented by parking areas found to the side of and behind the commercial buildings, mostly in privately owned lots. These private parking areas are often the first impression a customer has of a business and should be designed and maintained with care.



Parking should be located behind buildings when possible, and screened from adjacent streets.



A planting strip should be provided along the street. This variety of plantings provides a good example.



Locate parking to the side and rear of buildings as shown here.



Screening parking from view from adjacent streets can be done with plantings and fences.

## GUIDELINES

- Locate parking to the sides and rear of buildings. Parking should not come closer to the street than the front face of the building.
- Install adequate lighting to provide security in evening hours. Select fixtures that are appropriate to the district.
- Avoid demolishing existing buildings for parking.
- Screen parking from view of public streets with plantings, low walls, or fences.
- Use a combination of low plantings and trees in order to screen parking, provide shade, and create continuity with adjacent sites, while maintaining visibility for security purposes.
- Provide landscape areas that cover ten percent of the parking area. This should include interior landscaping on large parking lots.
- Include a planting strip at least five feet deep adjacent to any walkway and parking area property line.
- Pave parking areas with appropriate materials to enhance the character of the district. Exposed aggregate concrete is the most common material; other possibilities include brick, brick edging along other materials, loose contained gravel, cobblestone, or stamped concrete or asphalt surfaces. Asphalt is also an appropriate parking surface.

## E. Plantings and Trees

While many of the buildings in Gloucester's Main Street area cover much of the lot and do not leave much space for landscaping, even small areas of landscaping help to define the character of the village. The amount of space that is available for landscaping varies with the building type, as does the appropriate style of landscape treatment. Buildings of the residential form may have space for trees or substantial planting beds in front of and beside the building, while the traditional mercantile buildings typically may have room only for some plants in pots. The traditional non-mercantile buildings, being more institutional in form, may have room beside the building or sometimes in front for more formal plantings, including small trees.



Retaining existing trees when doing site work is an important factor.



Opportunities for landscaping can be found in some front setback areas, as well as beside and behind buildings and around parking areas.



The village is defined by an abundance of landscaping, including mature trees behind and between buildings, streetscape elements such as street trees and hanging baskets, and decorative plantings.



Ground cover, combined with small decorative trees, define the front setback zone of this building.



Landscaping can be used to dress up a blank wall that is visible from the street or from a parking area. This well-designed planting strip creates an inviting entrance.



Small plantings can define the base of a building in the front setback zone.



Foundation plantings help to soften this parking area.

## GUIDELINES

- Retain existing trees and plants that help define the character of the district.
- Use trees and plants that are indigenous to the area and that thrive in urban areas; replace diseased or dead plants and trees with indigenous species.
- Choose ground cover plantings that are compatible with adjacent sites, existing site conditions, and the character of the building.
- Use a variety of plantings and ground cover for accent in parking areas. Plantings used for screening purposes should be evergreen.
- Select mulching and edging materials carefully and avoid plastic edgings, lava, crushed rock, unnaturally colored mulch or other historically unsuitable materials.



Landscape areas used to shield parking areas from the view of the street and sidewalk are recommended. This variety of plant sizes and types adds interest to the planting area.

## F. Fences and Walls

Fences and walls occur in the Main Street area occasionally, usually between buildings that do not have a setback but do have a side yard; occasionally fences and walls define a building's front yard space. The addition of low walls or fences as a tool for screening parking areas is also appropriate.

Walls in the district are constructed mainly of brick. Fences found include metal and wood examples. New fences and walls should be compatible in material with the materials used on the building.



The historic walls surrounding Gloucester's courthouse square provide a historic precedent and inspiration for walls throughout the Main Street area.



Fences and walls can be used to delineate front setback areas, to divide parking lots, as retaining walls at changes in grade, or as edges for ramps.



Brick piers combined with metal fencing enclose a courtyard space.



Wood posts support an iron decorative fence to provide an edge to a parking area.



Brick piers double as planters to define an outdoor seating area on Main Street.



Wood fences are also common in the Main Street area and have an informal style contributing to the village character.

## GUIDELINES

- Wrought or cast iron and wood fences can be found in the district, as well as brick piers with metal fence. These existing materials should be retained.
- When a portion of a fence needs replacing, salvage original parts for a prominent location from a less prominent location when possible. Match old fencing in material, height, and detail. If this is not possible, use a simplified design of similar materials and height.
- The design of new fences and walls should blend with materials and designs found in the Main Street area.
- Relate materials to those used elsewhere on the property and on the structure.
- The height of the fence or wall should conform to zoning regulations and should not exceed the average height of other fences and walls of surrounding properties.
- The scale and level of ornateness of the design of any new fences or walls should relate to the scale and character of the existing building. Simpler and smaller designs are most appropriate on smaller size lots.
- Avoid the use of concrete block walls and chain link fences where they would be visible from the street.
- Avoid the use of solid masonry walls that visually enclose the property from surrounding more open neighboring sites.
- Vinyl fences are generally not appropriate along Main Street when visible from a public street or from access from a parking area.

## G. Lighting

Traditionally, there is little or no site lighting on private sites along Main Street. Building lighting varies by building form, from wall-mounted carriage lights on residential forms and non-mercantile buildings to recessed ceiling fixtures at storefront entries on traditional mercantile buildings. Generally, the street lighting in the village provides sufficient lighting along the street.



Building lighting is the most common private site lighting along Main Street, but opportunities exist for site lighting along walkways and parking areas.



Wall-mounted lights beside a building entrance are common throughout the village.



A recessed or hanging fixture at the ceiling of a recessed storefront is an appropriate way to light a storefront entry.



The wall-mounted fixture above the door on the side entry of this building adds interest.



## GUIDELINES

- Significant existing building lighting should be retained when possible.
- New building lighting should be appropriate to the style of the building.
- Lighting at signs and to highlight building elements is appropriate.
- Lighting should be provided in parking lots. Shielded parking lights that focus light on the parking surface should be used; decorative pedestrian-scaled walkway lighting may also be appropriate.
- Avoid overly bright lights and floodlights.



Gloucester's historically styled street lights can provide inspiration for site lighting fixture selection.

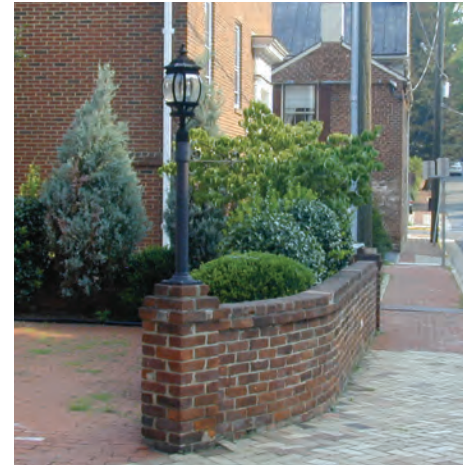

Pedestrian scale lighting can be used to light walkways or parking areas.



Traditional acorn style fixtures are used here to light a path through a courtyard space.



Site lighting can be incorporated into the design of walkways or steps, especially on residential form buildings.

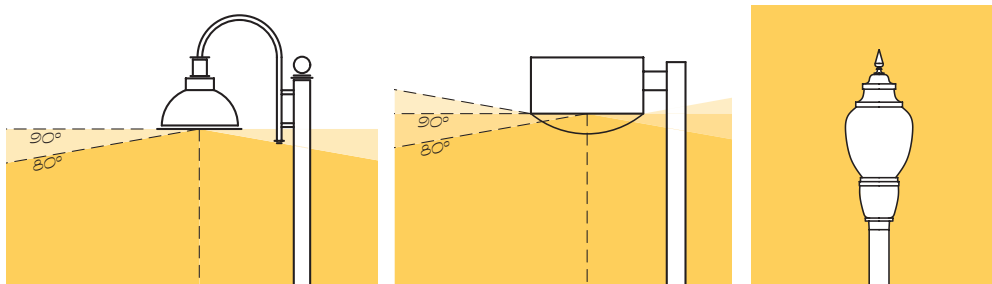

A full cut-off fixture (above left) does not allow any light to shine above the fixture. A semi-cut-off fixture (center) allows only minimal light to shine above the fixture. Traditional acorn-style fixtures (right) are usually non-cut-off but can be installed with interior caps so that light is directed downward.

## H. Mechanical and Utilities Screening

Site appurtenances, such as overhead wires, fuel tanks, utility poles and meters, antennae, exterior mechanical units, and trash containers are a necessary part of contemporary life. The placement of these items can either have a neutral impact on the character of the site and structure or detract from its historic appearance. Site features fall into two categories; those features that can be controlled by the property owner – antennae, satellite dishes, mechanical units, trash containers, etc.; and those that cannot – overhead wires, utility poles.

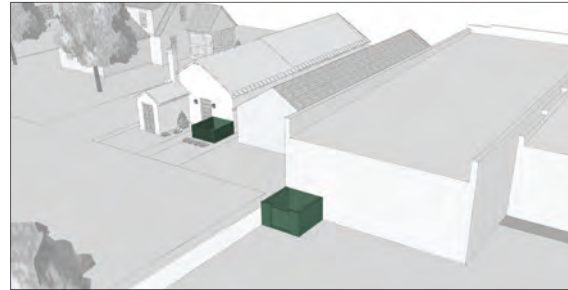

Screening should be used to shield appurtenances from the public view. The rear of the building is the most common location for utilities.



An existing business (top) planning to add mechanical equipment and using the rear entrance as access from parking can provide a painted wood and landscaped enclosure for utilities (above).



Using landscaping to screen equipment is appropriate.



A lattice fence provides a screen for mechanical units.



Screening built from wood and painted to coordinate with the building can be used to hide trash containers from parking areas.

### GUIDELINES

- Site appurtenances, such as heat pumps, should be placed in inconspicuous areas on the side and rear of the building and should be screened with appropriate plantings or fencing.
- Screening materials should match the materials of the building or be a compatible with the building's materials and style. Appropriate materials include brick and painted wood.
- Consider placing overhead utilities underground wherever possible.
- Place antennae and satellite dishes on inconspicuous rooftop locations.
- Screen any rooftop equipment from public view by placing units behind parapet walls or by providing screening with a material that coordinates with the building.

## I. Accessibility

Access ramps and lifts are a necessity for many older and historic buildings that were not built with at-grade entrances. The Americans with Disabilities Act (ADA) requires that public buildings be accessible to disabled users, or provide alternate accommodations. Similarly, work performed on existing commercial buildings will activate some accessibility requirements. Access ramps and lifts can usually be added to older buildings without substantially altering their significance if designed carefully and sensitively.

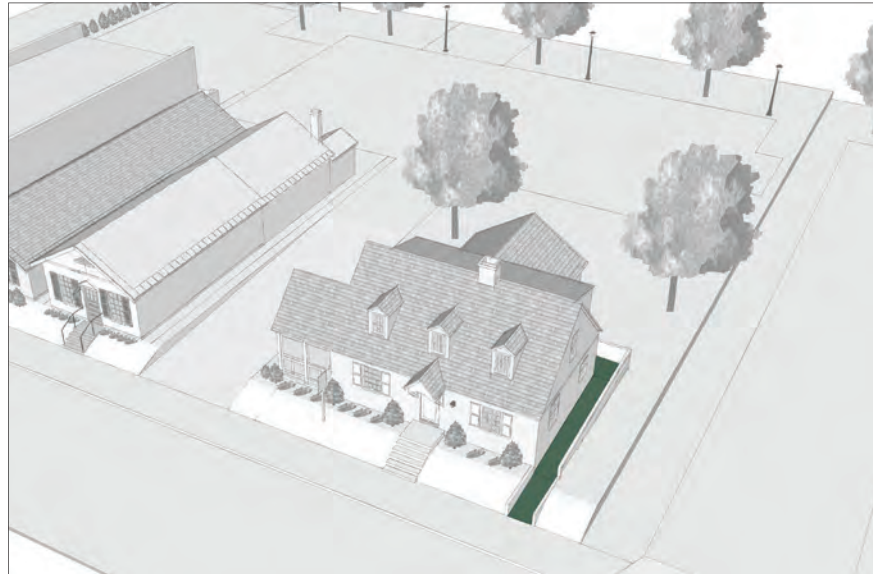

Accessible entrances for buildings with a raised floor level can be provided with a ramp that gives access to a side or rear entrance.



This ramp illustrates sensitive placement and design of handicap accessibility accommodations, allowing access through the side of the porch to the main entrance of the building. All new ramps must meet current building code.



An accessible entrance through a well-marked side entrance, directly from a parking area, is a good solution for many buildings.

### GUIDELINES

- Access should be located at a well-defined entrance to the building in such a way that will not cause permanent damage to character-defining features of the building. Often a secondary or rear entrance can be used as an accessible entrance.
- Design ramps to have the least visual effect on the building and site.
- Materials and details of ramps should be compatible with the materials and details of the existing building.
- When possible, use existing changes in grade to help achieve accessibility.



# Main Street Design Guidelines

Gloucester, Virginia

## GUIDELINES FOR EXISTING STRUCTURES—ELEMENTS **IV.**





## A. Introduction

A variety of building styles and forms contributes to the unique character of Gloucester’s Main Street. These styles and forms each have unique elements that define their particular character; the sum of these elements creates the cohesive environment of the Main Street area.

This chapter discusses the elements that comprise Gloucester’s Main Street buildings, beginning with storefronts and entrances, which are key to the district’s commercial character, and continuing with windows, architectural façade features such as cornices and parapets, and roofs. Finally, the treatment of the rears of buildings are addressed to guide building owners in dealing with secondary entrances, parking, and utilitarian issues that may not be visible from the street but are crucial to the function of a building.



The building forms in Gloucester vary from traditional mercantile to residential, resulting in a variety of building elements and styles.

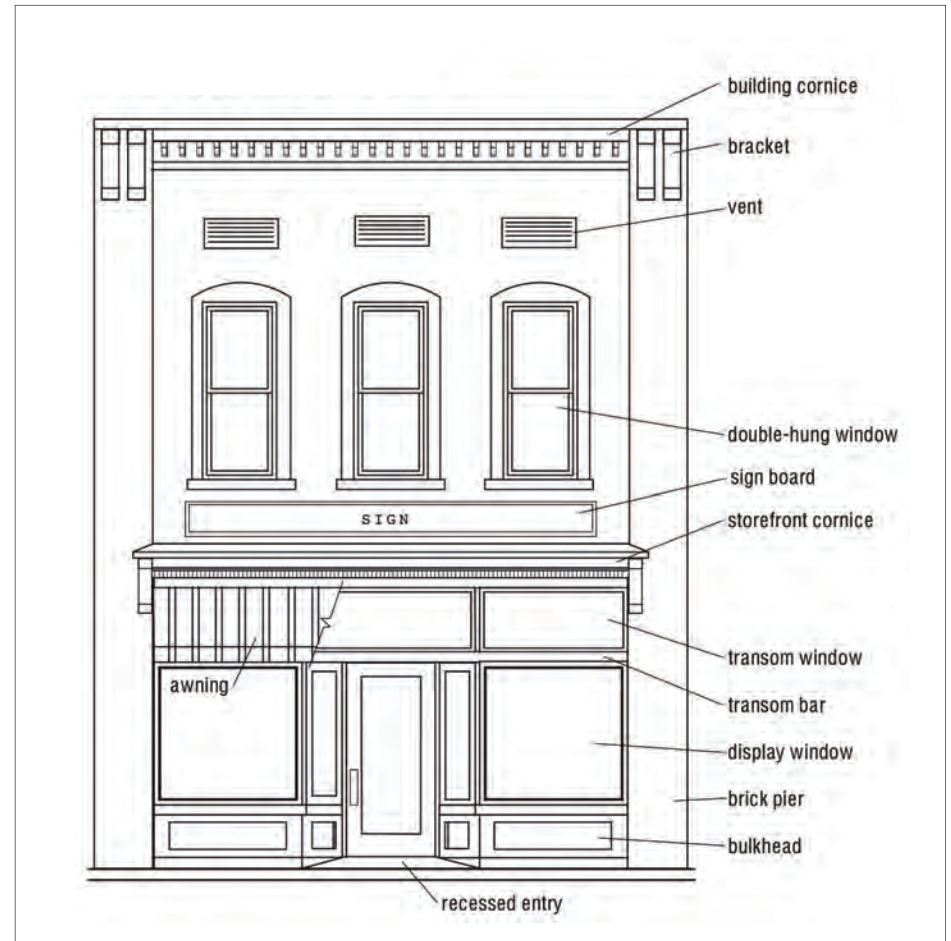

Typical downtown commercial buildings historically are made up of three parts: the cornice area, which can vary from simple to highly decorated; the upper facade, which may contain windows in multi-story buildings; and the storefront, which provides display space and an entrance.

**B. Storefronts and Doors**

The way in which a building opens to the street and greets and welcomes people is essential to its success as a commercial building. The majority of the buildings along Gloucester’s Main Street are of the traditional Main Street mercantile form and contain a ground floor retail or other commercial space that typically has display windows and an entrance door.

Historically, the primary street elevation of this building type has a predictable appearance with three distinct parts: the storefront, the upper facade area, and the cornice.

The upper façade area may contain windows on a two-story building. Many of Gloucester’s traditional mercantile buildings are one story; and in these cases, the upper facade may contain some decorative features or a sign area. Traditional mercantile buildings are generally built up to the property line and often adjoin neighboring buildings.

Gloucester’s non-mercantile and residential forms usually do not have a storefront. In these cases, the entrance door carries that importance as the first impression for a customer.



This traditional storefront has a recessed entry, decorative transom windows, and a storefront cornice.



The facades along Main Street vary in character. The view above shows buildings with a traditional storefront and a building with a more residential facade.



A historic view of Gloucester’s Main Street shows the scale of the village’s early buildings; storefronts were a typical feature on these commercial buildings. The Tidewater Telephone building is shown at left.



A more contemporary storefront is decorated with corbelled brick accents.



In addition to the two traditional front facades described on the previous page, Gloucester has a unique facade type that is distinct from these two standards: commercial buildings with large bay windows. Bay windows, typically a more residential architectural element, provide display space for retail uses and extend towards the sidewalk from the façade into the setback zone, reaching out into the public zone.

This use of the bay window, typical in Gloucester, adds another unique character-defining feature to the village feel. For the purpose of these guidelines, these bay windows should be treated similarly to storefronts.



A facade with multiple bay windows is a unique feature on Gloucester's commercial buildings.

Over time, commercial buildings and their storefronts are altered or remodeled to reflect current fashions or to eliminate maintenance problems. Sometimes these improvements are misguided and result in a disjointed, unappealing appearance. In other instances, improvements employ quality materials and sensitive design and may be as attractive as the original building. Often, in the latter cases, these changes should be retained.

The following guidelines will help determine what is worth saving and what should be rebuilt and provide guidance in the design, maintenance and treatment of storefronts and entrances.



Although some changes have been made to this storefront over the years, the basic design retains its integrity.



Full glass wood storefront doors are the most common and most appropriate doors in the Main Street area.



Aluminum storefront doors may be appropriate for modern buildings. Placement of wood doors with aluminum is not appropriate.



Decorative door trim, sidelights and transoms are character-defining features that should be retained.

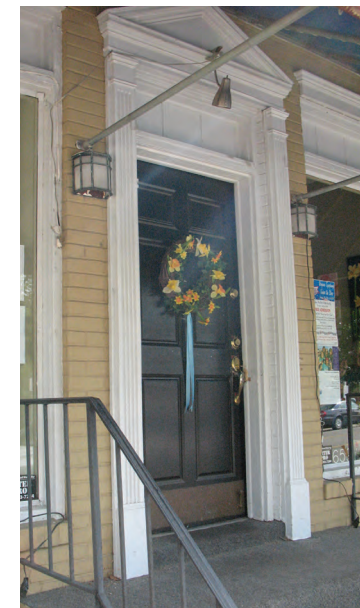

Solid six-panel doors are appropriate on residential form buildings.

## GUIDELINES FOR STOREFRONTS AND DOORS

- Before you begin making any changes to your building, conduct pictorial research to determine the design of the original buildings or early changes.
- Retain all storefront and bay window elements, materials, and features that are original to the building, are historically significant, or are sensitive remodelings. Provide maintenance as necessary.
- Repair as many original storefront and bay window elements as possible, particularly the glass, decorative details, and cornice.
- If your storefront has been covered with a newer material, carefully remove the new material to determine what original fabric remains and its condition.
- Remove any inappropriate materials, signs, or canopies covering the façade.
- Replace missing original elements, such as cornices, windows, and storefronts, if significant documentation is available to accurately reproduce these features. If not, design new elements that respect the character, materials and design of the building.
- Conform to the configuration and materials of traditional storefronts when designing new elements.
- Avoid creating false historical appearances, such as “Colonial,” “Olde English,” or other theme designs, that include inappropriate elements, such as mansard roofs, metal awnings, plastic shutters, inoperable shutters, or shutters on windows, where they never previously existed.
- Retain and repair significant existing doors, as well as any transoms, sidelights, fanlights, and surrounding trim.
- Replace doors that are beyond repair with a new or salvaged door of the same size, design, material and type as was used originally, or that is sympathetic to the building style, including number and orientation of any panels, and size and location of any glass. Replacing an early or original wood door with an aluminum storefront door is not appropriate.
- If a door is no longer needed, the door, trim, and hardware should be retained so that it appears to be a functional element of the building.

Elements of a Traditional Stile and Rail Door

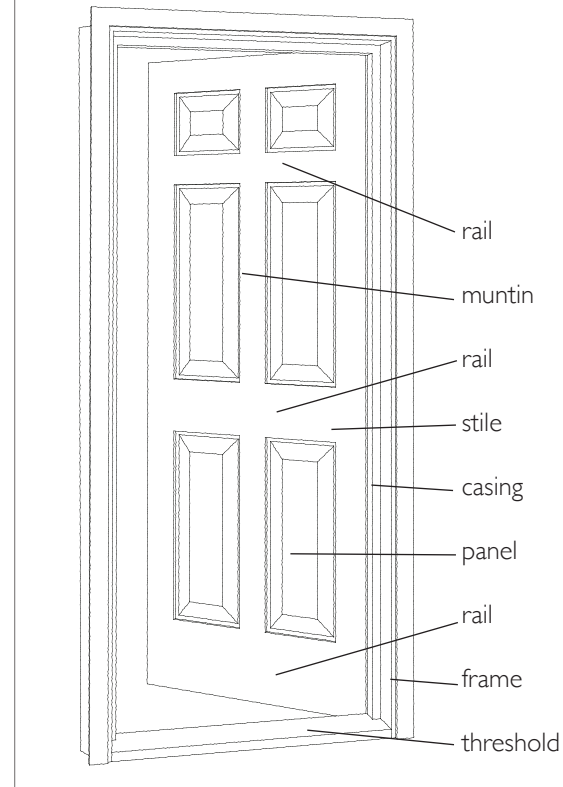

A traditional stile and rail door is appropriate for the residential building forms in the district.



A commercial door typically has a full glass panel for maximum transparency.

## C. Windows and Shutters

Windows add light to the interior of a building, provide ventilation, and allow a visual link to the outside. The window sash, framing and architectural detail surrounding the window plays a major part in defining a building's particular style, scale and character.

Because of the variety of architectural styles and building types in Gloucester's Main Street area, there is a corresponding variation of styles, types, and sizes of windows.

Windows are one of the major character-defining features on most buildings and can be varied by different designs of sills, panes, sashes, lintels, decorative caps, and shutters. They may occur in regular intervals or in asymmetrical patterns; bay windows are also common along Main Street. All of the windows may be the same in one building, or there may be a variety of types that give emphasis to certain parts of the building. Both wood and metal windows can be found in the Main Street area.



Windows vary in shape, type, and material throughout the Main Street area. Shutters are most common on residential form buildings.

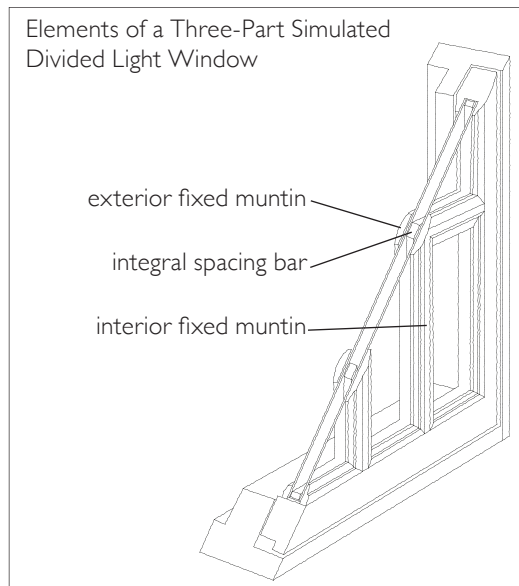

Elements of a Three-Part Simulated Divided Light Window

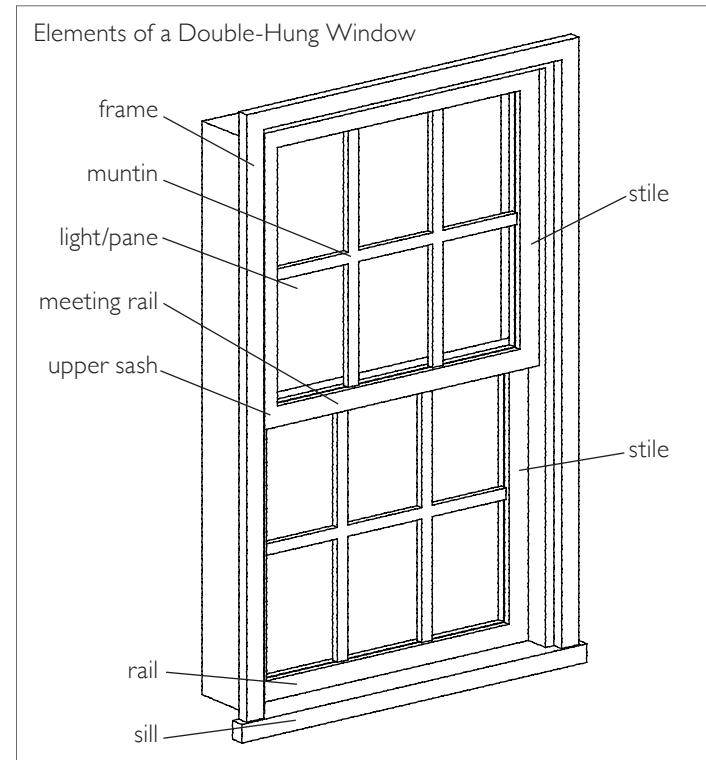

Elements of a Double-Hung Window

An example of a wood six-over-six divided light window is used to illustrate the parts of a typical window. The divided light patterns throughout the district vary by building style.



One-over-one double hung windows are common on some building styles. Here, a decorative fanlight transom adds interest.



Two-over-two double hung windows are typical of Victorian buildings. This pair exhibits some maintenance problems typical to wood windows which can be repaired.



Wood double-hung windows, such as this example with a six-over-six divided light pattern, are common.



Dormer windows are common on residential form buildings throughout the Main Street area. These dormers have six-over-six divided lights.

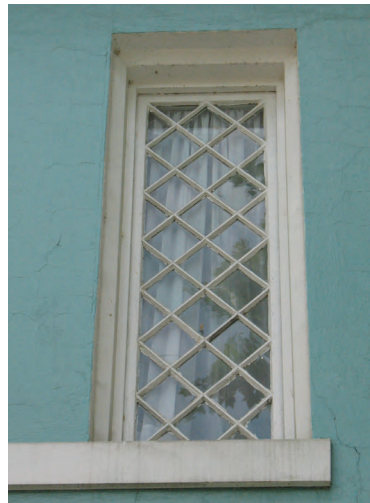

Decorative windows such as these shown here are important character-defining features of a building and should be retained.



## GUIDELINES FOR WINDOWS

- Retain and preserve original and historically significant windows that contribute to the character of a building, including their functional and decorative features, such as frames, sash, glass, muntins, sills, heads, moldings, surrounds, shutters, and hardware.
- Protect rare windows when possible, especially any original stained, leaded, etched, colored, or other specialty glass.
- Retain existing widow trim and preserve window trim details whenever possible. Sills and exterior frames should not be covered.
- Uncover and repair covered-up windows, and reinstall windows with their original dimensions where they have been blocked in.
- Repair original windows by patching, splicing, or consolidating such that existing material is retained to the highest possible extent. Wood that appears to be in poor condition because of peeling paint or separated joints often can be repaired, as can metal windows that appear to be in poor condition.
- If a window on the primary façade of a building must be replaced, consolidate with a window from a secondary elevation if possible.
- Replace windows and window features only if they are missing or beyond repair. If a window is badly deteriorated, replace only the sash if possible, retaining the frame and trim.
- Base reconstruction of missing windows on physical evidence or photographic documentation.
- If replacement of a significant deteriorated or missing window is necessary, replace the unit in-kind:
  - Match the existing window type (double hung, casement or otherwise) and opening height and width, and maintain the size and shape of window components.
  - Maintain the original number and arrangement of panes. True divided lights, or three-part simulated divided lights with integral spacer bars and interior and exterior fixed muntins are preferred.
  - Maintain the width, depth, and profile of existing rails, stiles, and muntins when possible.
  - Match the material of the original window.
  - Avoid the use of clip-in/false muntins and removable internal grilles. If the appearance of muntins and divided light windows is desired, the use of simulated divided light windows is recommended, with the muntins applied to the exterior and interior of the window to simulate the appearance of a true divided light window.
- Avoid cutting new openings and blocking in existing windows.
- If a window is no longer needed, the glass should be retained and the interior can be frosted, screened, or shuttered so that it appears from the outside to be in use.

**A GUIDE TO ENERGY CONSERVATION****Interior Storm Windows**

Storm windows made for interior use can be easily installed as an alternative to exterior storm windows and do not impact the appearance of a window from the street.

- Look for models with airtight gaskets.
- Ventilation holes and/or removable clips should be provided to ensure proper maintenance and avoid condensation damage.
- Avoid mullions, muntins or wide frames visible from the exterior of the building.

**Exterior Storm Windows**

An original wooden window with exterior storm window may provide as good of if not better insulation than a double-paned new window.

**Wood**

- Insulates better than metal.
- Can be painted to match trim.
- Easily repaired.
- Available with glass and screen inserts.

**Aluminum**

- Lighter weight than wood.
- Integrated glass and screen panels.
- Should be pre-painted to match the color of the window frame.

**Steps to Improve Thermal Efficiency**

- Weatherstripping
  - a. Rolled vinyl weatherstripping can be tacked in place on window frame.
  - b. Metal strips or plastic spring strips can be installed on rails and, when space allows, between sash and jamb.
  - c. Doors can be good insulators if they fit tightly and are weatherized. Install weatherstripping of spring bronze, felt, or new vinyl beading around the edges of the doorway.
- Sash Locks
  - a. Install on meeting rail to assure tight fit between upper and lower sash.
- Caulking, Putty
  - a. Caulk joints/seams around edges of window frame to avoid moisture penetration.
  - b. Replace deteriorated glazing putty and repaint to create weathertight seal.
  - c. Install new recessed metal tracks with springs to hold existing sash while providing a tighter fit to the frame on wood windows.

Elements of a Traditional Storm Window

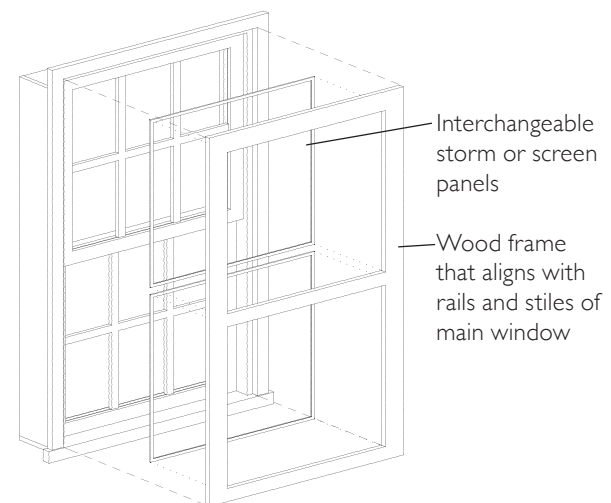



A louvered shutter on a brick building provides a good example of the proper mounting and hardware.



Shutters should be the same shape and size as the opening they are intended to cover.

## GUIDELINES FOR SHUTTERS

- Retain shutters, including original hardware, if they are original to the building.
- Repair existing shutters following the guidelines for wood found in Chapter 5: Guidelines for Materials.
- Replace shutters that are beyond repair with in-kind examples. Shutters should be operable or appear operable, should be mounted on hinges, and should be sized to fit the opening.
- Shutters should be constructed of wood, or a composite material that retains the characteristics of wood. Avoid vinyl and aluminum shutters.
- Avoid shutters on multiple or bay windows.

Three Typical Shutters

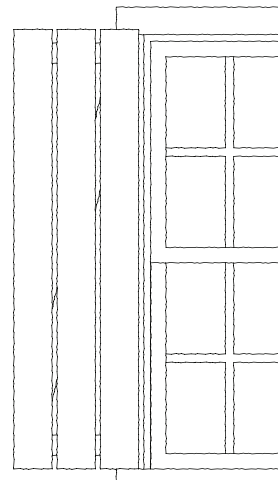

Board-and-Batten Shutter

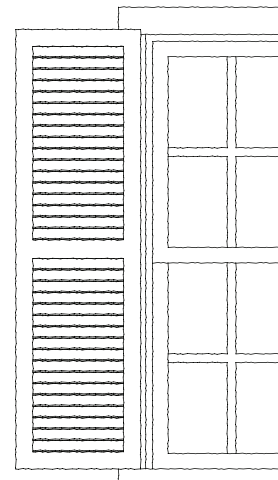

Louvered Shutter

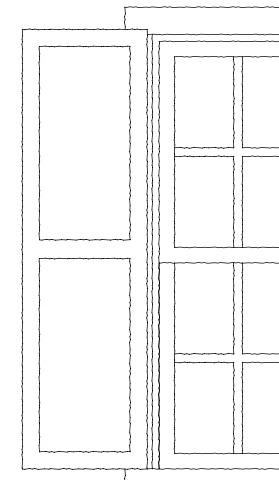

Paneled Shutter

## D. Cornices, Overhangs and Parapets

The cornice is the embellishment of the junction between the roof and the wall. Their material and design depend on the style and character of the building, and in Gloucester’s Main Street area can vary from a simple corbelled brick course on a vernacular commercial building to a heavy, detailed Classical cornice complete with dentils or modillions.

An overhang is the extension of the roofline past the wall plane and is often seen in Gloucester on buildings that are more residential in form, and can sometimes feature details such as exposed rafter tails.

Parapet walls are a common feature on Gloucester’s Main Street buildings, especially those that fall into the mercantile form. A parapet is the extension of the wall above the roof plane and can occur on one or multiple facades of a building. Parapets in the Main Street area vary from simple stucco walls to brick walls decorated with extensive corbelling.



Treatment of the junction between the roof and wall depends largely on the form of the building, as seen in the variety of types shown above.



Classically detailed cornices are typical on non-mercantile form buildings.

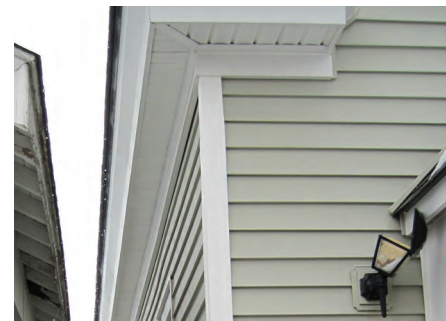

Exposed rafter tails, such as those visible on this overhang on the building to the left, are sometimes seen on residential form buildings in the district.

### GUIDELINES FOR CORNICES, OVERHANGS, AND PARAPETS

- Retain original cornices, parapets and eaves that define the architectural character of the building.
- Repair rather than replace existing features when possible. Match the original materials, details, and profiles.
- Replace a missing cornice, parapet or eave with one that is based on physical evidence or documentary photographs.
- Install new cornices and eaves with proper flashing and slope to ensure against water infiltration.
- Ventilate new cornices, parapets and eaves to protect against moisture buildup.
- Avoid replacing original trim with material that conveys a different period of construction or architectural style.



Parapet walls on mercantile form buildings can range from very simple (above left) to more decorative, such as the stepped, corbelled brick example at left.

A simply decorated boxed eave details a residential form building in the district (above).



## E. Roof

One of the most important elements of a structure, the roof serves as the “cover” to protect a building from the elements. Good roof maintenance is absolutely critical for the preservation of a roof and the rest of the structure.

Roof shapes in Gloucester’s Main Street area vary with the architectural styles and form of the buildings. Many mercantile buildings have flat or low-sloped roofs hidden behind parapet walls. Gable roofs are also common; hipped examples are less common.

Roofing materials vary from standing seam metal to various types of shingles, as well as flat roofing materials.

Roofing materials that are visible and significant should be retained and replaced in kind if necessary. Many of the roofs in the district are not visible, and the guidelines for appearance do not apply to these roofs.



Common roof forms include a mix of flat roofs hidden by parapet walls, gables perpendicular to the street, and gable roofs parallel to the street.



Roof forms and materials in the Main Street area vary greatly, creating a variety and texture that is unique to the village. In the top view above, many different forms can be seen; in contrast with the view below, a row of buildings with the same roof form creates continuity.

## GUIDELINES FOR ROOFS

- Retain original or significant roof materials, such as wood shingle, standing-seam metal, or slate whenever possible.
- Retain as much of a significant roof material as possible. Consolidate original roof materials to the most visible areas and use replacement materials on areas not in view from public ways.
- Preserve original roof shapes.
- Retain architectural features including roof cresting, finials, dormers, cornices, exposed rafter tails, and chimneys.
- Repair roof materials and elements in-kind with materials that duplicate the physical and visual characteristics of the original materials.
- Replace roof coverings when necessary, using new material that matches the original roof covering in composition, size, shape, color, and texture.
- Avoid replacing a deteriorated historic roof with a material that does not have the same visual qualities as the original.
- Repair and replace original decorative roof features in-kind using the original materials and historic photographs as a guide.
- Locate new skylights, solar panels, satellite dishes, vents and roof-mounted mechanical equipment to the rear or side of the roof where least visible from public roads, walkways and neighboring properties.
- Incorporate shingle-profile solar panels into a non-primary roof face when possible.
- Avoid adding dormers if they were not a part of the original design.



Typical roof forms (top to bottom): gable parallel to the street; end gable; gable behind a parapet wall; flat roof behind a parapet wall.

Roof materials (top to bottom): slate; wood shingles; standing-seam metal; asphalt shingles.

### TYPICAL ROOF MATERIALS AND MAINTENANCE

- *Slate*  
Although its use in Virginia is documented as early as Jamestown, slate was not easily shipped and did not enjoy wide popularity until canals and railroads made its transport more economically feasible in the mid-nineteenth century. Common types of slate found in Virginia include Buckingham slate, one of the hardest slates available, and Pennsylvania slate, noted for its variation in color. The life expectancy of Buckingham slate is approximately 150 years, whereas Pennsylvania slate will often start to delaminate in 75 years with a life expectancy of no more than 125 years.  
Faux slate is manufactured from recycled plastic and rubber and costs as little as one-third the price of natural slate and weighs less than half of the natural. When chosen carefully, these slates replicate the historic appearance of the real thing and can last up to 50 years.
- *Wood shingles*  
The availability of wood made this roofing popular with the first settlers, and regional stylistic characteristics developed over time. Although there was a decline in the use of wood shingles in urban communities in the nineteenth century due to fire concerns, wood shingle roofs endured in rural areas. In the early twentieth century, the Colonial revival, shingle and bungalow styles were responsible for a resurgence in the popularity of this material. Replacement roof shingles should replicate the appearance of the existing in material, thickness and shape. Longevity: 20-25 years.
- *Asphalt shingles*  
First produced in 1903 as individual shingles cut from asphalt roll roofing, these shingles were given a stone surface. By 1906, the multi-tab strip shingle was being marketed. By World War I, a number of factors, including its use of non-strategic materials, ease of transportation, fire retardant properties and lower costs, combined to increase its market share. Ceramic granules have replaced the original crushed stone, and fiberglass mats have replaced felt underlayment to improve this products durability. Longevity: 15-50 years depending on quality/warranty.
- *Copper*  
Among the first uses of copper roofing was the New York City Hall in 1764. It did not see widespread popularity until the latter part of the nineteenth century when large quantities of the metal began to be mined in Michigan. Due to high cost, it is more often used for flashing, gutters and downspouts. Since it does not need to be coated, copper weathers well and is easy to install. Longevity: 100 years.
- *Tin-plated iron*  
From its use at Thomas Jefferson's Monticello in 1800, this metal product was popular throughout the nineteenth century. As technology improved, the size of sheets grew from 10x14 inches in the 1830s to 20x28 inches in the 1870s.
- *Terne*  
The French word for dull, it was used to describe lead coated tin-plate patented in 1831. Less expensive than tin-plated iron, it became twice as popular by the end of the nineteenth century and was fashioned into shingles, sheets and standing-seam applications. A zinc-tin alloy on a steel substrate has now replaced the lead coated tinplate. Longevity: 30+ years.
- *Pre-finished Terne*  
Modern terne must be painted to ensure its life expectancy. This product comes pre-finished from the factory reducing later maintenance issues. Some suppliers have taken care to offer a color palette that approximates historic appearance rather than shiny coatings. Longevity: 30 years.
- *Terne-coated Stainless*  
This relatively new material consists of stainless steel to which has been applied a zinc-tin alloy. It does not need painting and can be worked in a manner to approximate historic standing-seam metal roof profiles. Longevity: 50-100 years.
- *Elastomeric roof coatings*  
These products can extend the life expectancy of a metal or built-up roof by reducing the roof's surface temperature and the harmful effects of solar radiation. These products should not be used to repair leaks. Leaks should be repaired using the original roofing material, roofing cement and reinforcing fabric. When used, an elastomeric coating should either match the paint color of the roof or a clear coating should be used with a matte finish. Longevity: 3-7 years.

## F. Rears of Buildings

The area behind commercial buildings is often forgotten and neglected. This area may be a utilitarian space for deliveries and storage of discarded goods. However, in some cases the rear of the building may provide the opportunity for a secondary entrance, particularly if oriented to a parking area.

The appearance of the back area then becomes important to the commercial district and to the individual business, as the rear entrance may be the first contact the customer makes with the business. Throughout the Main Street area there are buildings where the rear elevation is visible from a public street or used as a supplemental entrance.



A business's rear facade prior to construction.



A rendering illustrates potential improvements.



A photo of the completed project shows how an accessible entrance from the rear parking area has been made more inviting with restored doors, an enclosure for utilities, paint, and lighting.

### GUIDELINES

- Retain any original doors and windows that define the character of the building when possible. In general, avoid closing existing openings.
- Repair deteriorated windows and doors; add storm windows if necessary.
- Reopen blocked in windows when possible.
- If rear window openings need to be covered on the interior for merchandise display or other business requirements, consider building an interior screen while maintaining the character of the windows from the exterior.
- If security bars need to be installed over windows, choose a type appropriate for the window size, building style and required level of security. Avoid using chain link as a security cover over windows.
- Consolidate and screen mechanical and utility equipment in one location when possible.
- Install adequate lighting for customer and store security.
- Where a supplemental entrance is used at the rear of a building, or where the rear of a building is seen from a public street, consider adding walkways or paths that meet the same guidelines as those for the front entrance.
- Consider installing signs and awnings for rear entrances.
- Consider adding planters or a small planting area to enhance and highlight the rear entrance.
- Note building and ADA codes when, and if, changing the dimensions or design of a rear entrance. Meet all handicapped accessibility and egress requirements.

# Main Street Design Guidelines

Gloucester, Virginia

## SIGNS VI.





## A. Introduction

Signs are a vital part of commercial areas. A balance should be struck between the need to call attention to individual businesses and the need for a positive image of the entire district.

Signs can complement or detract from the character of a building depending on their design, placement, number, and condition

The character of signs should be harmonious to the character of the structure on which they are placed, which varies based on the building's type. Consider the relationship of surrounding buildings, compatible colors, appropriate materials, the style and size of the lettering and graphics, and the type of lighting

Historically significant signs on buildings should be retained if possible, even if the business is no longer in existence.

See the Zoning Ordinance for sign regulations; the following are recommended guidelines.



Signs provide vital information to customers about the presence of a business. Wall-mounted signs, freestanding signs, and projecting signs are aimed at a variety of pedestrian and vehicular traffic.



A series of projecting signs greet pedestrians along Main Street.

## B. Sign Types and Placement: On-Structure Signs

On-structure signs include wall-mounted signs, projecting signs, signs on windows and doors, and any signs placed on awnings or canopies. All these signs contribute to the maximum permitted on-structure signage, the limit to which is one square foot of sign per linear foot of building frontage, up to a maximum of 40 square feet for the building's primary façade.

For multi-tenant buildings, an on-structure limit of 15 square feet or one square foot per linear foot of frontage for each business, whichever is greater, is permitted up to the maximum. Half of the maximum amount is recommended for any secondary façades with public street frontage.



A before and after view of signage recommendations for this building illustrates a number of different sign types. Relocating the projecting sign to the corner increases visibility, especially at times of the year when the foliage is on the tree. Addition of a wall sign and window signs appeal to vehicular traffic and pedestrians, respectively.



## 1. Wall-Mounted Signs

These signs, also referred to as flat wall signs, are panels or individual letters mounted to the wall or cornice of a building. Large wall signs can be read by pedestrians from a distance and by passing motorists. Wall signs can be appropriate for both commercial and residential building forms.

- Place signs so that they do not obstruct architectural elements and details that define the design of the building.
- For mercantile building forms, it is appropriate to locate a wall-mounted sign above the storefront, within the frieze of the cornice, on a covered transom, on a pier that frames the display window, on unadorned flat surfaces of the facade, or in other areas clearly designed as sign locations.
- For residential building forms, wall-mounted signs can be attached to the wall at the first floor level.
- Lettering size: The lettering and symbols should typically be between 12 and 16 inches in height and allow for two to three inches of space between the lettering and the top and bottom of the sign band. The width of the lettering should extend no more than 75% of the width of the sign band.
- Maximum recommended size: 1 square foot of sign per linear foot of building frontage and up to a maximum of 40 square feet for the primary façade; half of this amount up to a maximum of 20 square feet for secondary facades with public street frontage is recommended. All wall signs are counted towards the overall on-structure signage allowance.
- A maximum height of 18" is recommended; wall signs should not project more than 6" from the face of the building.
- Upper-level tenants: A flat, wall-mounted directory sign can be used at each primary building entrance to represent upper floor tenants. Such a directory sign should not exceed 10 square feet and contributes to the overall on-structure signage allowance.

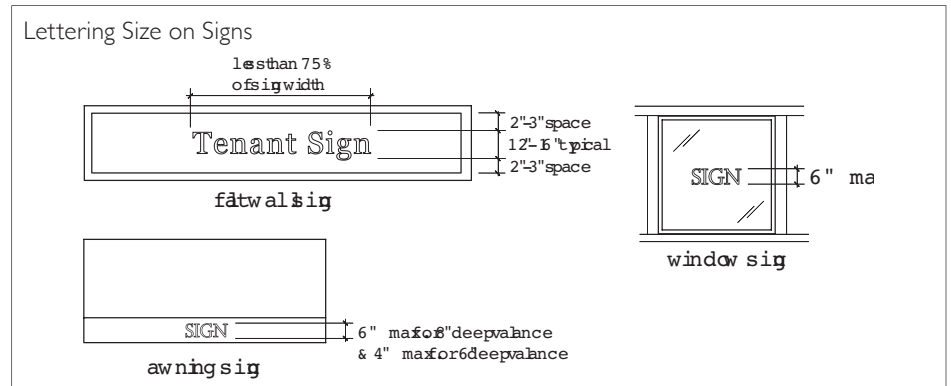

A wall-mounted sign of cut-out letters gives the historic name of the building. Tenant signage is posted on a freestanding monument sign.



A wall sign provides a simple identification of the business; window signs augment with more information.

## B. Sign Types and Placement: On-Structure Signs, continued

### 2. Projecting Signs

Hung from brackets or otherwise mounted so that they hang perpendicular to the building, these signs can also be attached to the underside of an approved awning. Projecting signs are intended to be read from a moderate distance by pedestrians.

- For commercial building forms, projecting signs should be placed at a height of at least 9 feet from the sidewalk and extend no more than 4 feet from the vertical surface of the building.
- For residential building forms, a small projecting sign can be attached to the wall at the first floor or to a porch column.
- Sign placement should never be higher than the sill line of the second floor windows, or the eave height on a one-story building.
- Maximum recommended size: 10 square feet per face, 6" maximum spacing between faces; this signage contributes to the maximum on-building signage size.



Projecting signs are common throughout the district and are often mounted from ornamental metal brackets.



A period-appropriate projecting sign idea for this 1930s building has the form of signs typical to that era.

### 3. Window and Door Signs

Painted or adhered window signs are intended for pedestrians and can include more specific information about a business.

These signs should be painted onto or adhered to display windows or entrance doors and should not be three-dimensional.

Window signs can be made with vinyl letters or painted by a professional sign painter. Avoid hand-painted or hand-made letters for window and door signs.

Avoid large temporary signs that block the view of window displays from outside the building.

- These signs are intended for pedestrians and should be placed with a center line approximately 5 1/2 feet above the sidewalk for good visibility, or can be located in the top or bottom 18 inches of the display window glass. Window signs may also be appropriate on the glazed area of doors. Window signs are not permitted in upper-story windows.
- The average height of lettering and symbols should be no more than six inches.
- Maximum recommended size: A window sign should obscure no more than 20% of the window glass.



A window sign placed at eye level in the center of the storefront window is ideally located for visibility.



The name and hours for this business are prominently displayed on the door.



The business name and slogan are incorporated into attractive window signage.

## B. Sign Types and Placement: On-Structure Signs, continued

### 4. Awning and Canopy Signs

A sign can be painted, screened, applied or sewn onto the valance area of an awning as appropriate.

- Avoid hand-painted or individually made fabric letters that are not professionally applied.
- Avoid backlit awning signs.
- Maximum recommended size: Typically, the drop of an awning valance measures between 6 and 8 inches. Letters should be sized to allow for an inch of open space at both the top and bottom of the valance, and the lettering should extend no more than 75% of the width of the awning. Awning and canopy signage counts towards the overall permitted on-structure signage.



This attractive streetscape in Hickory, North Carolina, illustrates the impact awning size signage can make.



Simple lettering on an awning sign identifies a business.

## C. Sign Types and Placement: Other Signs

### 1. Free-standing Signs

Free-standing signs are mounted to posts or other supports and placed in front of buildings that are set back from the street far enough to provide space for the sign. The Gloucester Code defines a free-standing sign as any sign that is not supported by, attached to, or painted on a building. These signs can be oriented to pedestrians, as well as to vehicular traffic, if they are placed correctly.

Gloucester's existing free-standing signs are often placed too high to be legible for pedestrians and are sometimes oriented parallel to the street instead of perpendicular to it, making them difficult to see for both pedestrians and vehicular traffic.

- Freestanding signs should be oriented perpendicular to the sidewalk for maximum legibility.
- Maximum recommended size: A pole-mounted, free-standing sign should be no higher than 12 feet, and the total sign area should not exceed 12 square feet.

Free-standing signs can be ground-mounted monument signs, especially appropriate for residential form buildings such as in this example.



A series of freestanding pole signs are oriented and scaled for vehicular traffic.



This pole mounted free standing sign provides locations for small projecting signs for additional information; the base doubles as a planter.

## 2. Temporary Signs: Sandwich Boards

Sandwich board signs can be used to communicate more information about the business to the passing pedestrian and can help to animate the street, drawing attention to open businesses.

- Sandwich boards are only permitted if a minimum clear sidewalk space of 3 feet can be maintained beside the sign.
- Sandwich board signs should be constructed of metal or wood.
- Wood signs should be constructed of medium density overlay (MDO) board or a similar quality material and not grained plywood.
- All edges should be covered with molding.
- Sandwich board-type signs should have a maximum of four colors that relate to the colors of the associated building.
- Letters should be scaled to the size of the sign.
- No national advertising trademarks or logos should be a part of the sign other than that of the business.
- Maximum size: ten square feet, with a maximum height of four feet.
- Sandwich boards should only be displayed during business, to draw attention to a business or product when it is available and to avoid unnecessarily obstructing the sidewalk.

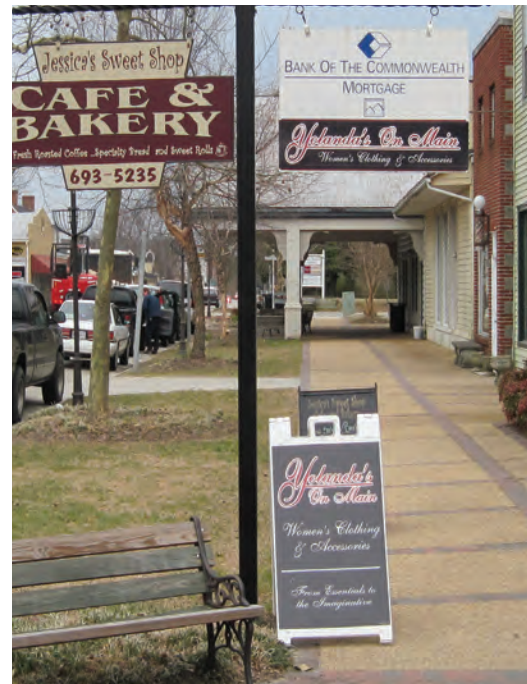

Sandwich board signs can enliven a streetscape, provide space for additional information about a business, and attract passersby to stop.



Sandwich board signs are only appropriate when enough clear sidewalk space can be maintained beside the sign. Many of Gloucester's sidewalks are wide enough to accommodate sandwich board signs.

## D. Number of Permanent Signs

The number of signs used should be limited to encourage compatibility with the building and discourage visual clutter.

- Signs should be limited to one of each sign type per building, and one additional wall sign per additional street frontage. A two-sided sign that is 6" or less in thickness counts as one sign.
- A building should have only one wall sign per street frontage.
- In addition to the existing permitted signs, each business in a building with rear entrances may have one small flat mounted sign not to exceed 6 square feet.



An example of a projecting sign paired with a window sign.



## E. Graphic Design, Compatibility, and Execution

Signs should be executed by sign professionals who are skilled at lettering and surface preparation.

Many signs are not readable or simply do not convey an image appropriate for the business or the building.

Often, sign painters or graphic designers can assist with sign design. Signs should be graphically simple in order to achieve maximum legibility from a distance. This does not mean a loss of creativity, simply an increase in readability.



A sign can take on a shape that gives potential customers a sense of the type of business or service offered.

## F. Shape, Color, Materials, and Lighting

### 1. Shape

- Shape of signs for commercial buildings can conform to the area where the sign is to be located.
- Likewise, a sign can take on the shape of the product or service provided, such as a shoe for a shoe store.

### 2. Color

- Use colors that complement the materials and color of the building, including accent and trim colors.
- Three colors are recommended, although more colors can be appropriate in exceptional and tastefully executed designs.



Shapes of projecting signs provide an opportunity for creativity to attract customers,



Simple shapes and coordinating colors give a unified appearance to the multiple tenants in this building.



### 3. Materials

- Use traditional sign materials such as wood, glass, gold leaf, raised metal or painted wood letters, and painted letters on wood, metal, or glass.
- Newer products, such as painted MDO, may also be used.
- Avoid shiny plastic type products.



### 4. Lighting

- Generally, signs should be indirectly lit with a shielded incandescent light source.
- Internally lit translucent signs, other than "Open" signs, are not permitted.
- Halo-lit signs with opaque letters are not permitted.

Wood signs and a metal bracket are traditional sign materials that are very appropriate in the Main Street area.

Simple cut out letters conform to the space in the storefront cornice.



Lighting of wall-mounted signs and projecting signs should be done with shielded incandescent light fixtures. These examples provide ideas for lighting designs.

## G. Multi-Tenant Buildings

- A master sign plan should be submitted for multi-tenant buildings.
- Upper-floor tenants should be represented at each primary entrance by a flat, wall-mounted directory sign.

## H. Other Signs

### 1. Neon Signs

Neon signs are often associated with early- to mid-twentieth century commercial design and are currently prohibited within the district.

- Historic signs that contain neon should be retained and restored. Historic buildings and signs are those over 50 years old and considered contributing to the potential Main Street historic district.

### 2. Murals

Murals may be used to add interest to blank end walls and should be carefully reviewed for compatibility with district character. While murals are not considered signs and therefore may not be reviewed by the County, the following guidelines should be followed if applying for a grant.

- A mural may not be used to advertise a product or activity at that site; if it does, it will be considered a sign.
- They should be painted onto a securely affixed removable material rather than onto the building itself, particularly if the wall is unpainted brick.

## I. Sign Maintenance

- Signs that are not properly maintained should be removed.
- Signs of a business no longer occupying a building or storefront should be removed unless it is historically significant.



Historic neon signs should be retained and restored, even if not made operable.



Neon "open" signs are encouraged as a way to increase visibility of businesses.



The Pocahontas mural at the Gloucester library is a good example of using public art to highlight historic events or people important to the history of the village.



# Main Street Design Guidelines

Gloucester, Virginia

## GUIDELINES FOR MATERIALS V.





## A. Introduction

Gloucester's Main Street buildings are constructed of traditional materials such as brick, wood, and stucco. These materials have a distinctive patina as they age. The continued preservation of these materials is what gives the historic village its unique character.

In this chapter you will find helpful information on the maintenance and repair of various materials that were used for structures throughout the Main Street area. You will also find guidance on replacement materials that may be appropriate for use on your building.

Paint and color are also addressed in this chapter. Paint is an effective and inexpensive way to enhance a building, giving the opportunity to highlight a building's unique architectural elements and enhancing the image of the district.



The variety of materials found throughout the Main Street area make up the rich texture of the district. Here, brick, stone, glass, metal, stucco, and wood make up the streetscape.



Many buildings are made up of multiple materials. Here, stucco and block are painted the same color to blend in with each other.



Brick is a common building material in Gloucester, typically with wood trim elements.

## B. Wood

The flexibility of wood has made it the most common building material throughout much of America's building history. Because it can be shaped easily by sawing, planing, carving, and gouging, wood is used for a broad range of decorative elements, such as cornices, brackets, shutters, columns, storefronts, and trim on windows and doors, as well as for major elements such as framing, siding, and shingles.



Wood is most often found on trim elements in Gloucester's Main Street area. Left: this building's cornice, bay windows, doors, and door surround are wood. Above: the porch, door, trim, and shutters are typical examples of wood elements.



Wood is a popular cladding material, primarily on residential form buildings but also on some mercantile buildings in the district. Beaded siding is used on this building.

### GUIDELINES

- Retain original and historic wood features including framing, cladding and any decorative elements.
- Retain wood features that define the overall character of the building, including cornices and brackets.
- Repair rotted or missing sections rather than replacing the entire element.
  - Use epoxy consolidants where possible.
  - Patch, piece or consolidate with materials to match the existing, using care to maintain existing profiles.
- Replace wood elements only when they are rotted beyond repair.
  - Match the original in material, texture, dimensions, and design.
  - Base the design of reconstructed elements on pictorial or physical evidence from the actual building rather than from similar buildings.

## MAINTENANCE

- Wood requires regular maintenance and will last for a very long time if it is well-maintained. The main objective is to keep it free from water infiltration and wood-boring pests.
- Inspect wood surfaces for signs of water damage, rot, and pest infestation.
  - To test for rotted wood, jab an ice pick in to the wetted wood surface at an angle and pry up a small section. Sound wood will separate in long fibrous splinters while decayed wood will separate in short irregular pieces.
  - Alternatively, insert the ice pick perpendicular to the wood. If it penetrates less than 1/8", the wood is solid; if it is more than 1/2", it may have dry rot.
  - Even when wood looks deteriorated, it may be strong enough to repair with epoxy products.
- Keep all surfaces primed and painted in order to prevent water infiltration.
- Allow pressure-treated wood to season for a year before painting it. Otherwise, the chemicals might interfere with paint adherence.
- Identify sources of moisture problems and take appropriate measures to remediate them including:
  - Remove vegetation that grows too closely to wood.
  - Repair leaking roofs, gutters, downspouts, and flashing.
  - Ensure proper ventilation.
  - Maintain proper drainage around the foundation to prevent standing water.
  - Recaulk joints where moisture might penetrate a building.
- As necessary, use appropriate pest poisons, following product instructions carefully.
- Do not pressure wash wood, as it can damage the wood and may also force moisture underneath the siding and into the framing system.

Typical Wood Siding Profiles

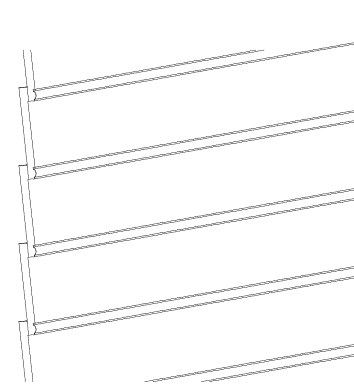

Beaded Siding

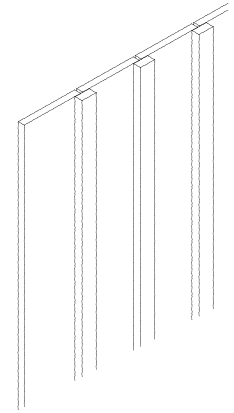

Board & Batten

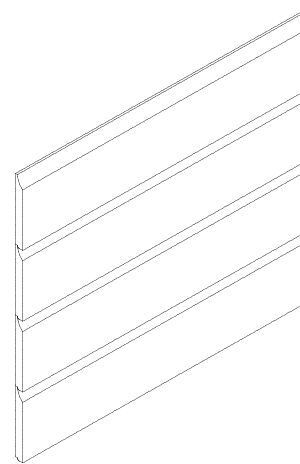

German Siding

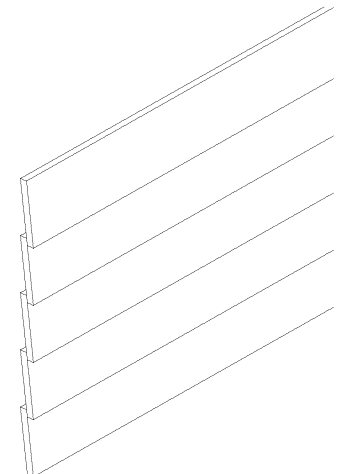

Lapped Siding



## C. Masonry

Masonry includes brick, stone, terra cotta, concrete masonry units, concrete, tile, mortar, and stucco (stucco is addressed in more detail in the following section). Masonry is used primarily for wall surfaces and also on cornices, pediments, lintels, sills, and decorative features. Color, texture, mortar joint type, and patterns of masonry help to define the overall character of a building.

Brick is the most common type of masonry used in Gloucester, sometimes painted; stucco is also a common wall finish.



Brick is the most common type of masonry found in Gloucester's Main Street area and can be found on all the building forms. Brick corbelling can be used to create a decorative effect on a parapet wall.

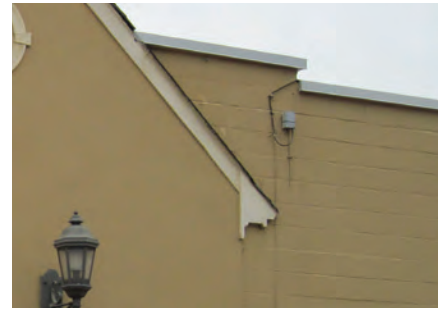

### GUIDELINES

- Retain masonry features, such as walls, cornices, window surrounds, steps, and columns, which are important in defining the overall character of the building.
- Leave unpainted masonry unpainted.
- When repairing or replacing a masonry feature, respect the size, texture, color, and pattern of masonry units, as well as mortar joint size and tooling. Match mortar composition in strength, color, and texture.
- When bricks need to be replaced due to deterioration that has caused spalling, they should be replaced with bricks of the same size, color and texture.

Other types of masonry are less common but add visual interest and texture to the district, such as the examples at left.

## MAINTENANCE

- Most major masonry problems can be avoided with monitoring and prevention.
- Prevent water from causing deterioration by ensuring proper building and site drainage: remove vegetation too close to the building, repair leaking roof and gutter systems, secure loose flashing around chimneys, and caulk joints between masonry and wood.
- Ensure that cracks do not indicate structural settling or deterioration.
- Repair cracks and unsound mortar with mortar and masonry that matches the historic material.
- Carefully remove deteriorated mortar and masonry in a way that does not damage surrounding masonry.
- Patch stone in small areas with a cementitious material which, like mortar, should be weaker than the masonry being repaired and should be mixed accordingly.
- Repair broken stone or carved details with epoxies. Skilled craftsmen should undertake application of such materials.
- The use of waterproof, water-repellent, or non-historic coatings on masonry is discouraged. They often aggravate rather than solve moisture problems.

### Typical Brick Bond Patterns

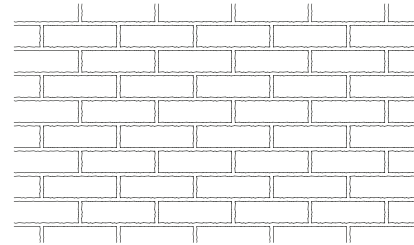

Running Bond

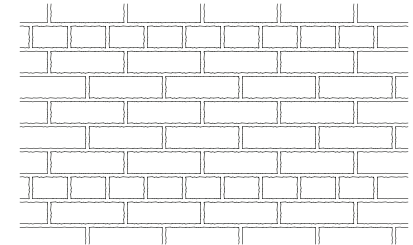

5 Course Common Bond

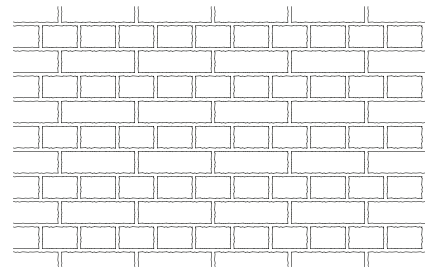

English Bond

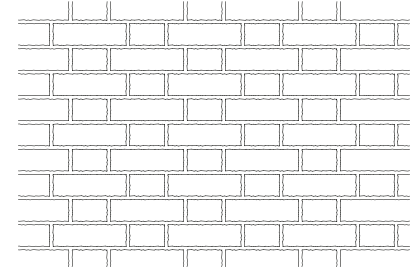

Flemish Bond



Unpainted running bond.



Painted 7-course common bond.

## CLEANING

- Clean masonry only when necessary to remove heavy soiling, stop deterioration, or remove heavy paint build-up.
- Use chemical paint and dirt removers formulated for masonry cautiously. Do not clean with chemical methods that damage masonry, and do not leave chemical cleaners on the masonry longer than recommended.
- The best method for cleaning unpainted brick is low-pressure wash with detergents. A low-pressure wash should be no more than 200 psi, equivalent to the pressure in a garden hose.
- Higher pressure waterblasting or chemical cleaning with an inappropriate cleanser can do irreparable damage. Test methods and cleaners on a small, inconspicuous part of the building, and look for damage caused by improper cleaning, such as chipped or pitted brick, washed out mortar, rounded edges of brick, or a residue or film.
- Older brick may be too soft to clean and can be damaged by detergents and the pressure of the water. Always test all methods to ensure that no damage will occur.
- Avoid sandblasting masonry.



An example of the impact brick cleaning can have: before cleaning (above left); and after chemical cleaning (above). A close-up view of the cleaned brick and brick that has not been cleaned on the adjacent building illustrates the difference (left).

## REPOINTING

Old bricks are different from new bricks and the mortar, the material that makes the joints, has to be different as well. An improper mortar mix can damage historic brick. Professionals experienced in working with old masonry can guide you in appropriate repointing methods.

- When repointing, only repair areas where mortar has deteriorated. Sound mortar should be left intact.
- Remove deteriorated mortar by carefully hand-raking the joints.
- Do not remove mortar with electric saws or hammers that damage the surrounding masonry.
- Match existing mortar strength: Brick expands and contracts with freezing and heating conditions. Old mortar moves to relieve the stress; if a hard, Portland cement mortar is used, the mortar does not flex as much, causing the brick to crack, break, or spall.
- Match existing mortar composition: Mortar of older brick buildings has a high lime and sand content. Replacement mortar should be composed primarily of lime (1 part) and sand (2 parts). Some Portland cement (ASTM C-150 Type I) can be included in the lime portion for workability but should make up no more than 20 percent of the lime and cement combined. It is also possible to have the original mortar analyzed and replicated.
- Match existing mortar appearance: Duplicate old mortar joints in width, profile and color. Cut out old mortar to a depth of one inch and repoint to match original joints, retaining the original joint width.
- Avoid using a “scrub” coating, in which a thinned, low-aggregate coat of mortar is brushed over the entire masonry surface and then scrubbed off the bricks after drying, as a substitute for traditional repointing.
- Consultation with a professional brick mason experienced in historic brickwork is advised. Always check references and view a historic mason’s previous work.

Typical Masonry Joints

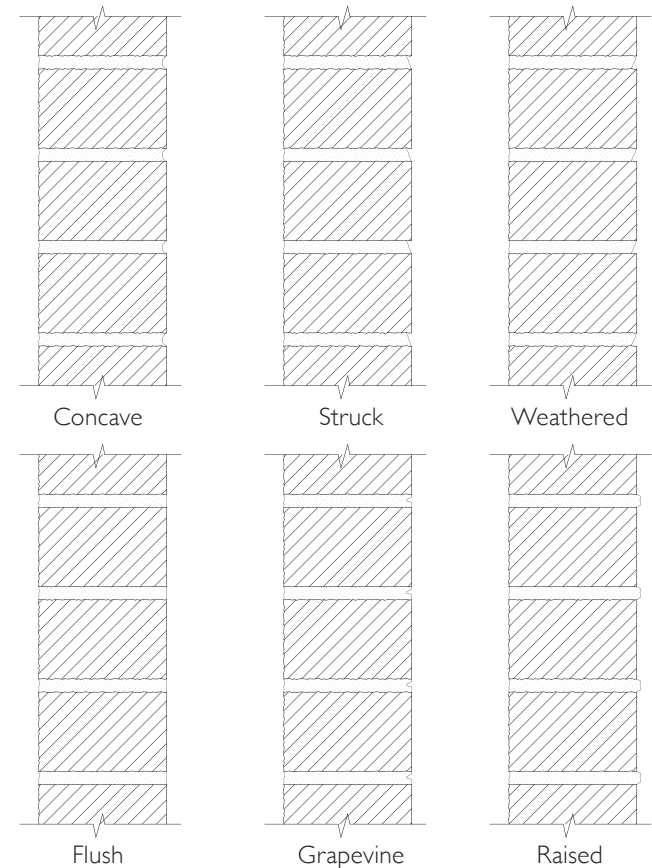

This photo shows professional brick masons repointing a historic brick building. The loose mortar has been removed and new mortar matching the original in composition is used to fill the joints.

## D. Stucco

Stucco is a type of exterior plaster applied to exterior walls, usually on masonry buildings. It may be applied directly over masonry, or applied over wood or metal lath on a wood structure. Stucco can be finished in numerous surface textures dictated by the style of the building including smooth, roughcast, and sponge, and can even be scored to resemble masonry units. The majority of Gloucester's stucco buildings have a smooth finish.

While stucco is considered a protective coating, it is highly susceptible to water damage, particularly if the structure underneath the stucco is damaged. Historic stucco needs regular maintenance in order to keep it in good condition. Historically, the materials under the stucco were not intended to be seen so complete removal of stucco in these instances is considered inappropriate.



Stucco can be smooth or sometimes is scored to resemble stone.

Stucco damage reveals the material underneath.



### GUIDELINES

- Retain and maintain stucco as a character-defining material in the district.
  - Repair stucco or plastering by removing loose material and patching with a new material that is similar in composition, color, and texture.
- Do not use commercial caulks or other compounds to patch the stucco. Because of the difference in consistency and texture, repairs made with caulk will be highly visible and may cause more damage than good.
- Use a professional plasterer for stucco repair. A qualified tradesperson will assess the damage and perform an analysis to match the new stucco to the existing material.
- Stucco may be tinted or pigmented and was sometimes whitewashed or color-washed. When replacing or repairing stucco, have a professional match the color or tint of the existing material.
- After repairs have been made, many stucco buildings will require repainting.

### MAINTENANCE

- Clean a stucco building using the most gentle means possible, preferably a low-pressure water wash and soft bristle brush. Take care not to damage the surface texture.
- Repair any water damage to the underlying structure to provide a sound base for necessary stucco repairs.



Metal is commonly used on decorative elements on historic buildings, such as this cornice and pediment.



Metal is a popular roofing material in Gloucester's Main Street area.

## E. Metal

Cast iron, steel, tin, copper, aluminum, bronze, galvanized sheet metal, and zinc are some of the metals found throughout Gloucester's village Main Street area. Metal is used primarily for roofs, as well as for decorative elements such as canopies, cornices, storefronts, and fences.

### GUIDELINES

- Architectural metals should be retained if possible.
- Repair or replace these metals as necessary, using identical or compatible materials. Some metals are incompatible and should not be placed together without a separation material.
- Substitute materials, such as certain composite products or wood, may be considered for reconstructing missing metal elements if it is not technically or financially feasible to replace them with the original material.
- Do not remove the patina of metals, such as bronze or copper, since it provides a protective coating and is a historically significant finish.

### CLEANING

- When cleaning metal is necessary, use the gentlest means possible. Do not sandblast copper, lead, or tin.
- Prepare for repainting by hand-scraping or brushing with natural bristle brushes to remove loose and peeling paint. Removing paint down to the bare metal is not necessary, but removal of all corrosion is essential.
- Clean cast iron and iron alloys (hard metals) with a low-pressure, dry-grit blasting (80-100 pounds per square inch), if gentle means do not remove old paint properly. Protect adjacent wood or masonry surfaces from the grit. Copper, lead, and tin can be cleaned with chemicals or heat.

## F. Glass

In addition to the clear glass used in windows and storefronts, a number of more modern types of glass were introduced in the late nineteenth and early twentieth centuries.

Prismatic glass was introduced in the 1890s and was primarily used for storefront transoms through the 1930s. These molded glass tiles reflected light in to the interior of the building and were typically joined together using zinc coming.

The popularity of structural pigmented glass, sold under brand names such as Vitrolite and Carrara Glass, dates to the early twentieth century. It was marketed as a modern, cost-effective alternative to marble. Technological advances allowed existing materials to be used in new ways and contribute character-defining materials synonymous with the Art Deco, Streamline and Moderne architectural styles. A few of Gloucester's buildings date to this era, and these materials should be preserved.



A historic photo shows structural pigmented glass decorating the storefront (above).



A surviving example of structural pigmented glass on a 1930s facade shows cracks in some of the panels, which can be repaired.

A decorative glass transom is an important character-defining feature of this building.

### GUIDELINES

- Retain original or historic window glazing when possible. If necessary, replace glass with new glass with as many characteristics to match the historic glass as possible, including color, thickness, and glazing method.
- Retain character-defining applications of historic structural pigmented glass.
- Maintain structural pigmented glass through the repair of cracked or open cement joints with tinted silicone compounds.
- Repair rather than replace cracked structural glass panels. Repair will prevent further damage from moisture infiltration. Small repairs can be made by using flexible caulk in a color that matches the historic glass.
- If it is necessary to remove structural glass panels due to adhesive failure, commercial solvents should be used to dissolve the hardened mastic and allow the panels to be removed without damage.
- Pigmented structural glass panels should be reapplied to a clean surface with an asphalt mastic adhesive similar to the original, rather than silicone, butyl, rubber or epoxy products.
- Pigmented structural glass is no longer manufactured so finding replacement pieces can be difficult. Consolidate the original materials to the most prominent location, and use substitute materials on less visible elevations.
- Spandrel glass may be an appropriate substitute for the historic glass panels if the color, size and reflectivity of the original materials can be approximated.

## G. Substitute Materials

A building's historic character is a combination of its design, age, setting, and materials. Synthetic materials do not have the same patina, texture, or light-reflective qualities as original materials and, therefore, detract somewhat from a building's historic character.

The exterior walls of a building, because they are so visible, play a very important role in defining its historic appearance.

Modern siding materials have changed over time but have included asbestos, asphalt, vinyl, aluminum, cement, and synthetic stucco. These have been used to artificially create the appearance of brick, stone, shingle, stucco, and wood siding surfaces.

Substitute materials have also been developed for trim elements. Composite trim materials vary from urethane, available in custom-formed lengths, to cellular PVC, which is able to be milled. Flat board dimensional materials are available in wood-resin composites and cement board but are not able to be worked in the traditional manner of wood. When decorative wood features are beyond repair, composite or fiberglass replacement elements may be appropriate if they replicate the appearance of the original element.



This series of photos shows a cornice that was covered with substitute materials (far left). Upon removal, it was discovered that extensive damage had occurred from moisture that was trapped behind the material (center). Repair and some replacement was necessary for the restoration of this character-defining feature (to the right).

### GUIDELINES

- Historic buildings and elements should not be resurfaced with new material that does not duplicate the original historic fabric. The introduction of new material will alter the historical and architectural character of the building.
- Aluminum, vinyl, and asphalt siding are not appropriate as a replacement product in the district.
- Resurfacing with substitute materials may have the potential to create or accelerate existing decay problems, because moisture can be trapped in areas that are not visible.
- Use composite trim only if it replicates the dimension, scale, and overall appearance of the original trim.
- Choose materials that may be painted to allow for a change in colors.
- Avoid replacing historic window, door, cornice, or storefront trim unless it is deteriorated beyond repair.



## H. Paint and Color

A properly painted building accentuates its character-defining details. Painting may be one of the least expensive ways to maintain building elements and make a building an attractive addition to the Main Street area.

In many instances buildings are painted inappropriate colors, or colors are placed on the building incorrectly. Some paint schemes use too many colors, while others paint all building elements the same color – neither one of these is a preferred treatment.



The accent brick work on this mercantile facade is lost in one paint color (left). A warmer palette, with accent colors for decorative brick, create a livelier appearance for this thriving business (below).



### GUIDELINES

- Keep existing painted materials well painted.
- Do not paint masonry that is unpainted.
- Paint unpainted aluminum-frame storm windows and doors to match other trim.
- Use high-quality paint and follow the manufacturer's specifications for preparation and application.
- Avoid the use of liquid vinyl coatings (commonly known as “liquid siding”) as these coatings may not allow structures to properly disperse moisture causing an accelerated rate of structural decay hidden by the coating. Also, the thickness of these coatings can obscure character-defining details and are difficult to remove.



An example from another community in Virginia illustrates how paint colors can be out the architectural details of a building (right) that were not noticeable when the building was painted one color (above).



## Preparation for Paint

*NOTE: Lead paint was used on both the interiors and exterior of buildings through the mid-twentieth century; therefore, it is likely that any building that is more than fifty years old will contain some lead paint.*

- Remove loose and peeling paint down to the next sound layer using the gentlest means possible: hand-scraping and hand-sanding for wood and masonry, and wire brushes for metal.
  - Professional chemical removal of paint may be acceptable in certain situations, if performed by a contractor experienced in working on historic buildings.
  - Burning old paint off is discouraged as it is a fire hazard and can permanently damage the surface of the wood.
  - Avoid the use of sandblasting, open flames, or high-pressure water wash to remove paint from masonry, soft metal or wood.
- Prime surfaces if bare wood or metal is exposed, or if you are changing types of paint, to allow new paint to adhere properly.
  - Do not apply latex paint directly over oil-based paint as it might not bond properly and may pull off the old oil-based paint.
  - Be sure to use metal primers when painting metal.
- Ensure that all surfaces are free of dirt, grease, and grime before painting.



For most buildings, a palette of three colors is appropriate. Here, a commercial building and a residential form illustrate a warm neutral wall color set off by a white trim color and a dark accent color. The residential building adds interest with a brighter red accent on the door.

## Color Selection

- Select a color scheme appropriate to the time period in which your building was constructed.
- Use natural colors for walls and trim and reserve brighter colors for accents such as doors, signs, and awnings.
- Professional paint analysis to determine the original and later colors is available but not necessary.



Crisp black and white recall the glass panels original to this building.



The Art Deco style of the historic Calvin Hotel provides an opportunity for more vibrant color.



Gloucester's historic Texaco Station provides a good example of historic research to determine the original paint colors of white and green.



Main Street Design Guidelines  
Gloucester, Virginia

AWNINGS AND CANOPIES VII.





## A. Introduction

Awnings and canopies protect pedestrians from the weather, shield window displays from sunlight, and help to conserve energy. They can also contribute to the overall image of commercial areas of the historic districts by providing visual continuity for an entire block and covering any unattractively remodeled transoms areas above storefronts. Fabric awnings are a traditional feature on Main Street buildings and are the most appropriate addition to Gloucester's Main Street.

In addition, awnings offer the business owner additional façade visibility because of their color and the possibility of adding an awning sign (See *Chapter 6: Guidelines for Signs*).



A deep canopy that is actually an extension of the gable roof provides a covered place for street furniture.



Fabric awnings are a traditional Main Street element, and provide shade and the opportunity for protecting outdoor seating areas.



Traditional non-mercantile buildings in the district often have classical porticos, which function in a similar way to an awning or a canopy, protecting customers from the weather and creating an outdoor gathering space.

## B. Types

### 1. Standard Sloped Fabric Awnings

Whether fixed or retractable, sloped fabric awnings are the traditional awning type and are appropriate for most buildings along Main Street, both residential and commercial forms.

### 2. Boxed or Curved Fabric Awnings

A more current design treatment, this type of awning may be used on non-historic or new commercial buildings but is generally discouraged in the district.

### 3. Canopies and Marquees

Appropriate on some commercial buildings, canopies and marquees must fit the storefront design and not obscure important elements such as transoms or decorative glass.

- Historic marquees and canopies should be retained and maintained on historic building facades.
- Fixed canopies with sloped roofs, including mansards, shed and hipped roofs, are generally not appropriate and should not be added to buildings along Main Street.



Traditional sloped fabric awnings add color and interest to traditional storefronts and shade the display windows from direct sunlight.



Historic canopies, such as this canopy on the historic Calvin Hotel building, should be retained and restored.



A more modern sloped fabric awning with open sides is appropriate for this facade.

## C. Design and Placement

- Choose awning designs that do not interfere with existing signs or distinctive architectural features of the building or with street trees, street signs or other elements along the street.
- Awnings should fit the width and shape of any storefront or window openings that it covers. For instance, straight sloped awnings work best on rectangular storefronts while curved awnings work well on arched openings.
- Make sure that the bottom of the awning valance is at least seven (7) feet above the sidewalk.

## D. Materials, Color and Lighting

- Fabric awnings are the traditional material for awnings and should be used in the Main Street area.
- Avoid using metal and plastic awnings or shiny, plastic-like fabrics.
- Coordinate awning colors with the overall building color scheme.
- Solid colors, wide stripes, and narrow stripes may be appropriate but not overly bright or complex patterns.
- Backlit awnings or canopies used as illuminated signs are not appropriate in the historic districts.



Awnings on this row of buildings unify the facades.



A modern awning shape on this building is finished in a color to match the doors.



Gooseneck fixtures highlight this building's awnings.



Traditional awning shapes and placement can be updated with the use of different materials.





# Main Street Design Guidelines

Gloucester, Virginia

## APPENDICES



## I. General References

### A. PRESERVATION BOOKS

A large variety of books addressing various topics of preservation are available from the National Trust for Historic Preservation web site. Subjects that may be of interest include: Basics of Preservation, Building Better Organizations, Living in a Historic Community, Communities and Sprawl, Economics of Historic Preservation, Fund Raising, Advocacy, Preservation and the Natural Environment, Preserving Special Building Types, Disaster Preparedness, Program Models, Heritage Tourism and Heritage Educations. Website: [www.preservationbooks.org](http://www.preservationbooks.org)

### B. NATIONAL REGISTER BULLETINS

The National Park Service offers a series of free publications covering a variety of subjects, including the National Register of Historic Places, preservation planning, historic landscapes and historic documentation methods. Bulletins may be ordered from the National Register web site: [www.cr.nps.gov/nr/publications/bulletings.htm](http://www.cr.nps.gov/nr/publications/bulletings.htm)

### C. TECHNICAL PRESERVATION SERVICES ONLINE EDUCATION

A number of interactive websites hosted by the Technical Preservation Services of the National Park Service are available at [www.cr.nps.gov/hps/tps/online\\_ed.htm](http://www.cr.nps.gov/hps/tps/online_ed.htm) and cover topics including moisture, maintenance, rehabilitation and tax incentives.

## II. Resource Organizations and Websites

### A. LOCAL RESOURCES

#### Gloucester County

##### Planning Department

6582 Main Street, PO Box 329  
Gloucester, VA 23061  
(804) 693-1224  
[www.gloucesterva.info/planning](http://www.gloucesterva.info/planning)

##### Code Compliance

6582 Main Street  
Gloucester, VA 23061  
Building Inspections: (804) 693-2744  
Zoning: (804) 693-4040

#### Economic Development Authority

(804) 693-1415  
[www.gloucedereda.org](http://www.gloucedereda.org)

#### Gloucester Main Street Preservation Trust & The Gloucester Main Street Association

PO Box 265  
6894 Main Street  
Gloucester, VA 23061  
(804) 695-0700  
[www.gloucester-virginia.org](http://www.gloucester-virginia.org)

### B. STATE RESOURCES

#### Virginia Department of Historic Resources

The Virginia Department of Historic Resources maintains information on the Commonwealth's historic architecture and archaeological sites. It is the mission of the Department to foster, encourage, and support the stewardship of Virginia's significant historic, architectural, archaeological, and cultural resources. Website: [www.dhr.virginia.gov](http://www.dhr.virginia.gov)

#### Capital Region Preservation Office

Ann Andrus, Director  
2801 Kensington Avenue  
Richmond, VA 23221  
Ph: (804) 367-2323 X133  
Fx: (804) 367-2391  
Email: [ann.andrus@dhr.virginia.gov](mailto:ann.andrus@dhr.virginia.gov)

#### APVA/Preservation Virginia

APVA/Preservation Virginia mission is to preserve and promote Virginia's heritage of irreplaceable historic structures, collections, communities and archaeological sites and thereby provide cultural, economic and educational benefits to the public.

204 West Franklin Street  
Richmond, VA 23220  
Ph: (804) 648-1889  
Fx: (804) 775-0802  
Website: [www.apva.org](http://www.apva.org)

## II. Resource Organizations and Websites, Cont.

### B. STATE RESOURCES, CONT.

#### Virginia Historical Society

Founded in 1831, the Society's mission is to collect, preserve, and interpret the Commonwealth's past for the education and enjoyment of present and future generations.

428 North Boulevard  
Richmond, VA 23220  
Ph: (804) 358-4901  
Fx: (804) 355-2399  
Website: [www.vahistorical.org](http://www.vahistorical.org)

#### Library of Virginia

Serving the archival and research needs of Virginians since 1823.

Website: [www.lva.lib.va.us/](http://www.lva.lib.va.us/)

#### University of Mary Washington Center for Historic Preservation

Since 1980 the Center has served as a research and public outreach organization that sponsors conferences, organizes student fieldwork, and provides professional and technical assistance to property owners, local governments and private organizations.

<http://www.umw.edu/cas/chp>

#### Virginia Chapter - American Planning Association

Founded in 1970 this organization promotes the use of planning to address physical, economic and social change.

Website: [www.vapanning.org](http://www.vapanning.org)

#### Virginia Department of Housing and Community Development

The Department of Housing and Community Development (DHCD) is dedicated to improving the quality of communities in Virginia.

Website: [www.dhcd.virginia.gov/](http://www.dhcd.virginia.gov/)

#### Virginia General Assembly

A site with links to the State Assembly, the Legislative Information System and the Commonwealth Net Server.

<http://legis.state.va.us/>

#### Virginia Society AIA

The VSAIA is the state component of the American Institute of Architects. Since 1914, VSAIA has represented the professional interests of architects in the Commonwealth of Virginia.

Website: [www.aiava.org](http://www.aiava.org)

#### Virginia's Main Street Program

Since 1985, Virginia Main Street has been helping localities revitalize the economic vitality of downtown commercial districts using the National Main Street Center's successful Main Street Approach.

Website: [www.dhcd.virginia.gov/mainstreet/](http://www.dhcd.virginia.gov/mainstreet/)

### C. FEDERAL/NATIONAL RESOURCES

#### Advisory Council on Historic Federal Preservation

The Advisory Council on Historic Preservation is an independent Federal agency created by the National Historic Preservation Act of 1966 (NHPA) and is the major policy advisor to the Government in the field of historic preservation. <http://www.achp.gov>

#### Association for the Preservation of Civil War Sites

Founded in 1987 by a group of historians deeply concerned over the irresponsible development and eradication of America's Civil War battlefields, the Association for the Preservation of Civil War Sites is a membership-driven national non-profit organization headquartered in Washington, DC. APCWS acts to preserve and protect these hallowed grounds by directly purchasing the property or negotiating protective easements. <http://www.civilwar.org>

#### Cyburbia

Cyburbia contains a comprehensive directory of Internet resources relevant to planning, architecture, urbanism and other topics related to the built environment.

Website: [www.cyburbia.org](http://www.cyburbia.org)

#### National Alliance of Preservation Commissions

The NAPC is a private, non-profit 501(c)(3) corporation that builds strong local preservation programs through education, training, and advocacy.

[www.uga.edu/sed/pso/programs/napc/napc.htm](http://www.uga.edu/sed/pso/programs/napc/napc.htm)

---

## II. Resource Organizations and Websites, Cont.

---

### C. FEDERAL/NATIONAL RESOURCES, CONT.

#### **National Conference of State Historic Preservation Officers**

The National Conference of State Historic Preservation Officers is the professional association of the State government officials who carry out the national historic preservation program as delegates of the Secretary of the Interior pursuant to the National Historic Preservation Act (16 USC 470). [www.ncshpo.org](http://www.ncshpo.org)

#### **National Archive and Records Administration**

The National Archive's mission is to ensure ready access to essential evidence that documents the rights of American citizens, the actions of federal officials, and the national experience. <http://www.archives.gov>

#### **National Center for Preservation Technology and Training**

NCPTT promotes and enhances the preservation and conservation of prehistoric and historic resources in the United States for present and future generations through the advancement and dissemination of preservation technology and training. <http://www.ncptt.nps.gov/About-Us.aspx>

**National Park Service: Heritage Preservation: Heritage Preservation Services.** A web site offering information on preservation planning, grants, tax credits, training, news, mapping and legislation. <http://www.cr.nps.gov/hps/>

#### **National Park Service: Links to the Past**

A comprehensive listing of links relating to history and culture. Subjects include grants, how-to, tax incentives, standards and guidelines, and regulations. <http://www.cr.nps.gov/preservation.htm>

#### **National Trust for Historic Preservation**

The National Trust for Historic Preservation, chartered by Congress in 1949, is a private, nonprofit organization dedicated to protecting historic resources. It fights to save historic buildings, and the neighborhoods and landscapes they anchor through education and advocacy. <http://www.nationaltrust.org/>

#### **NTHP's Main Street Center**

Provides information and resources on the Main Street program of downtown revitalization through historic preservation and economic development. <http://www.mainstreet.org/>

#### **Partners for Sacred Places**

This organization promotes the stewardship and active community use of America's older and historic religious properties. <http://www.sacredplaces.org>

#### **Preservation Action**

Founded in 1974, Preservation Action advocates federal legislation to further the impact of historic preservation at the local, state and national levels. <http://www.preservationaction.org>

#### **Preserve Net**

Begun in December of 1994, Preserve Net is comprehensive database for preservationists organized into sections on economics, law, awards, education, and outside links. <http://www.preservenet.cornell.edu/>

#### **Scenic America**

Scenic America is the only national nonprofit organization dedicated to preserving and enhancing the scenic character of America's communities and countryside. [www.scenic.org](http://www.scenic.org)

#### **Society for American Archaeology**

The Society for American Archaeology (SAA) is an international organization dedicated to the research, interpretation, and protection of the archaeological heritage of the Americas. [www.saa.org](http://www.saa.org)

#### **Society for Commercial Archeology**

Established in 1977, the SCA is the oldest national organization devoted to the buildings, artifacts, structures, signs, and symbols of the 20th-century commercial landscape. [www.sca-roadside.org](http://www.sca-roadside.org)

#### **Sprawl Watch Clearinghouse**

The Sprawl Watch Clearinghouse mission is to develop tools, techniques, and strategies to manage growth, and to make them accessible to citizens, grassroots organizations, environmentalists, public officials, planners, architects, the media and business leaders. [www.sprawlwatch.org](http://www.sprawlwatch.org)

#### **Surface Transportation Policy Project**

A nationwide coalition working to ensure safer communities and smarter transportation choices. [www.transact.org](http://www.transact.org)

## II. Resource Organizations and Websites, Cont.

### D. TECHNICAL AND PROFESSIONAL LINKS

#### **American Cultural Resource Association**

ACRA's mission is to promote the professional, ethical and business practices of the cultural resources industry, including all of its affiliated disciplines, for the benefit of the resources, the public, and the members of the association. <http://www.acra-crm.org/>

#### **American Institute of Architects**

Provides information on both consumer and professional issues. <http://www.aia.org>

#### **American Planning Association**

The American Planning Association and its professional institute, the American Institute of Certified Planners, are organized to advance the art and science of planning and to foster the activity of planning — physical, economic, and social — at the local, regional, state, and national levels. <http://www.planning.org/>

#### **Conservation Online**

CoOL, a project of the Preservation Department of Stanford University Libraries, is a full-text library of conservation information, covering a wide spectrum of topics of interest to those involved with the conservation of library, archives and museum materials. <http://palimpsest.stanford.edu/>

#### **Journal of Architectural Conservation**

An essential Journal for practitioners and scholars in the field, the Journal of Architectural Conservation, offers a wide-ranging review of research and innovative practice.

[http://www.donhead.com/Journal\\_of\\_20Architectural\\_Conservation.htm](http://www.donhead.com/Journal_of_20Architectural_Conservation.htm)

#### **Old House Journal Online**

The OHJ online offers publications, forums, historic house plans and a restoration directory. <http://www.oldhousejournal.com>

#### **Preservation Trades Network**

Provide a much needed opportunity for both experienced and novice members of the preservation trades community to exchange experiences, skills, and ideas. <http://iptw.org/home.htm>

#### **Preservation Web**

Preservation Web is an online guide to thousands of specialized services and products you need to successfully restore, rehabilitate and preserve America's historic buildings. It is hosted through Restore Media, publisher of Traditional Building, Period Homes, and Old House Journal. <http://www.preservationweb.com/>

#### **Traditional Building Magazine Online**

This web-site is a gateway to leading suppliers of traditionally styled products and related services. These products are appropriate for restoration and renovation of older structures — as well as traditionally styled new buildings. <http://www.traditional-building.com/>

**ADAPTIVE USE.** Recycling an old building for a use other than that for which it was originally constructed. Adaptive re-use can involve a sensitive rehabilitation that retains much of a building's original character, or it can involve extensive remodeling.

**ADDITION.** A new part, such as a wing, ell, or porch, added to an existing building or structure.

**ALTERATION.** A visible change to the exterior of a building or structure.

**BARGEBOARD.** A sometimes richly ornamented board placed on the verge (incline) or the gable to conceal the ends of rafters.

**BAY.** A part of a structure defined by vertical divisions such as adjacent columns or piers.

**BAY WINDOW.** Fenestration projecting from an exterior wall surface and often forming a recess in the interior space.

**BRACKET.** A wooden, stone or metal decorative support beneath a projecting floor, window, or cornice.

**CAPITAL.** The upper portion of a column or pilaster.

**CERTIFICATE OF APPROPRIATENESS.** Approval given by an architectural review board for any exterior alterations to a building within a historic district. A certificate of appropriateness deems that the work is appropriate, as it will not devalue the historic character of a building or environment. *To be updated based on process.*

**CLADDING.** Any exterior wall covering, including masonry.

**COBRA-HEAD LIGHT FIXTURE.** A commonly used street light fixture in which the luminaire is suspended

from a simple, curved metal arm.

**COLUMN.** A vertical support, usually supporting a member above.

**COMPLEX ROOF.** A roof that is a combination of hipped and gable forms.

**COPING.** The top course of a wall which covers and protects the wall from the effects of weather.

**CORBELING.** Courses of masonry that project out in a series of steps from the wall or chimney.

**CORNICE.** The upper, projecting part of a classical entablature or a decorative treatment of the eaves of a roof.

**CUPOLA.** A small structure crowning a roof or tower.

**DENTIL.** Small square blocks found in series on many cornices, moldings, etc.

**DORMER.** A small window with its own roof projecting from a sloping roof.

**DOUBLE-HUNG SASH.** A type of window with lights (or windowpanes) on both upper and lower sashes, which move up and down in vertical grooves one in front of the other.

**DOWNSPOUT.** A pipe for directing rainwater from the roof to the ground.

**EAVE.** The edge of the roof that extends past the walls.

**FACADE.** The front face or elevation of a building.

**FANLIGHT.** A semicircular window with radiating muntins, typically located above a door.

**FENESTRATION.** The arrangement of the openings of a building.

**FINIAL.** An ornament that caps a gable, hip, pinnacle, or other architectural feature.

**FLASHING.** Pieces of metal used for waterproofing roof joints.

**FRIEZE.** A horizontal band, sometimes decorated with sculpture relief, located immediately below the cornice.

**GABLE ROOF.** A pitched roof in the shape of a triangle.

**GLAZING.** Another term for glass or other transparent material used in windows.

**HIPPED ROOF.** A roof with slopes on all four sides. They are more common on older buildings than on those built after 1940.

**INFILL BUILDING.** A new structure built in a block or row of existing buildings.

**INTEGRITY.** Authenticity of a property's historic identity, evidenced by the survival of physical characteristics that existed during the property's historic period.

**LATH.** Narrowly spaced strips of wood upon which plaster is spread. Lath in modern construction is metal mesh.

**LEADED GLASS.** Glass set in pieces of lead.

**LIGHT.** A section of a window; the glass or pane.

**LINTEL.** A horizontal beam over an opening carrying the weight of the wall.

**MOLDING.** Horizontal bands having either rectangular or curved profiles, or both, used for transition or decorative relief.

**MUNTIN.** A glazing bar that separates panes of glass.



**OVERLAY ZONING DISTRICT.** A set of legal regulations on properties in a particular area or district that are additional requirements to the existing zoning regulations in effect for those properties.

**PARAPET.** A low wall that rises above a roof line, terrace, or porch and may be decorated.

**PATINA.** Usually a green film that forms naturally on copper and bronze by long exposure or artificially (as by acids) and often valued aesthetically for its color.

**PEDIMENT.** A triangular section framed by a horizontal molding on its base and two raking (sloping) moldings on each of its sides. Used as a crowning element for doors, windows, over-mantels, and niches.

**PIER.** An upright structure serving as a principal support.

**PILASTER.** A pier attached to a wall with a shallow depth and sometimes treated as a classical column with a base, shaft, and capital.

**PITCH.** The degree of slope of a roof.

**PORTE-COCHERE.** An exterior shelter often used to shelter a driveway area on the side of a building.

**PORTICO.** An entrance porch often supported by columns and sometimes topped by a pedimented roof; can be open or partially enclosed.

**PRESERVATION.** The sustaining of the existing form, integrity, and material of a building or structure and the existing form and vegetation of a site.

**QUOINS.** Large stones, or rectangular pieces of wood or brick, used to decorate, accentuate and reinforce the corners of a building; laid in vertical series with, usually, alternately large and small clocks.

**REHABILITATION.** Returning a property to a state of utility through repair or alteration which makes possible an efficient contemporary use while preserving those portions or features that are significant to its historical, architectural, and cultural values.

**REMODEL.** To alter a structure in a way that may or may not be sensitive to the preservation of its significant architectural forms and features.

**RENOVATION.** See REHABILITATION

**RESTORATION.** Accurately recovering the form and details of a property and its setting as it appeared at a particular period of time, by removing later work and/or replacing missing earlier work.

**RETROFIT.** To furnish a building with new parts or equipment not available at the time of original construction.

**REPOINT.** To remove old mortar from courses of masonry and replace it with new mortar.

**REVEAL.** The depth of wall thickness between its outer face and a window or door set in an opening.

**RISING DAMP.** A condition in which moisture from the ground rises into the walls of a building.

**SASH.** The movable part of a window holding the glass.

**SETBACK.** The distance between a building and the front of the property line.

**SIDELIGHTS.** Narrow windows flanking a door.

**SIGN BAND.** The area that is incorporated within or directly under the cornice of a storefront and that contains the sign of the business in the building.

**SILL.** The horizontal water-shedding member at the bottom of a door or window.

**SPALLING.** A condition in which pieces of masonry split off from the surface, usually caused by weather.

**STABILIZATION.** The re-establishment of a weather-resistant enclosure and the structural stability of an unsafe or deteriorated property while maintaining the essential form as it currently exists.

**STANDING-SEAM METAL ROOFS.** A roof where long narrow pieces of metal are joined with raised seams.

**STILE.** A vertical framing member of a paneled door.

**STRING COURSE.** A projecting horizontal band of masonry set in the exterior wall of a building.

**SYNTHETIC SIDING.** Any siding made of vinyl, aluminum, or other metallic material to resemble a variety of authentic wood siding types.

**TRANSOM.** In commercial buildings, the area of windows in the storefront above the display windows and above the door.

**VERNACULAR.** Indigenous architecture that generally is not designed by an architect and may be characteristic of a particular area. Many simpler buildings that were constructed in the late-nineteenth century and early-twentieth century are considered vernacular because they do not exhibit enough characteristics to relate to a particular architectural style.

## Owning Property in the Main Street Area

---

Proper maintenance of a building includes periodic inspections to identify problems before they cause significant damage. Regular maintenance will stop any deterioration already begun and provide an easy and less expensive way to maintain the physical condition of your building. It is a good idea to keep documentation of yearly maintenance for present and future homeowners.

Perform this maintenance check once each year, preferably after a moderate rainfall.

### Roof

---

#### *What to look for...*

- ❑ **Materials:** Is there warping, severe wear, cracking, lumps, curling, decay, splitting, rusting, loose pieces, missing pieces, broken pieces, thin material?
- ❑ **Structure:** Is the roof level, or does it sag?
- ❑ **Roof flashing, gutters, downspouts:** Is there rusting, paint loss, sagging, missing, or torn pieces, blockages, poor drainage?
- ❑ **Decorative elements (finials, snow breaks, cresting, etc.):** Are there loose pieces, rust, missing pieces, deteriorated cornice?
- ❑ **Chimney or parapet:** Is the chimney sagging, leaning, or bowing? Are the mortar joints tight? Is the chimney cap rusting or missing? Are bricks loose or missing?

#### *Estimated Life Span and Repairs Required*

1. Metal roofing: repair and paint every 5-10 years. Others: 20-50 years.
2. Repair and repaint other roof materials every 5-10 years.

### Exterior Walls

---

#### *What to look for...*

- ❑ **Structure:** Are the walls leaning, bowing, bulging? Are cracks evident? Are the door and window openings square?
- ❑ **Materials:** Is the surface of masonry or stucco flaking, crumbling, or are units missing? Is the mortar loose or crumbling? Is the wood siding cracked, loose, rotted, or split? Do courses of siding appear straight or wavy? Is cast iron or pressed metal rusting, pitted, or missing? Are the walls stained? Is paint peeling, cracking, blistering, or chalking?
- ❑ **Porch floors:** Are there cracks, splits, loose boards, missing boards, rot?
- ❑ **Decorative elements:** Is there peeling paint, cracks, or loose pieces?

#### *Estimated Life Span and Repairs Required*

1. Dry, properly maintained wall structure should last indefinitely.
2. Masonry units can last for centuries with proper maintenance.
3. Pointing should last 50 years or more.
4. Replace clapboards that are beyond repair (estimated life span 150 years with proper maintenance).
5. Painted surfaces may require repainting every 5-10 years.
6. Paint previously painted masonry surfaces approximately every 10 years.
7. Repaint wood surfaces every 5-8 years.
8. Wood floorboards should last 50 years or more.

## Windows and Doors

*What to look for...*

- ❑ **Operation:** Do windows and doors open and close smoothly?
- ❑ **Glass:** Is the glass broken? Is the glazing secure? Do the glass panes fit securely? Are the stops and putty secure?
- ❑ **Frames, etc.:** Do the frame, muntins, sash, and door show signs of rust, rot, or insect damage? Is the threshold rotted? Are there open joints around the frames and trim?
- ❑ **Hardware:** Is the hardware operational and in good repair?
- ❑ **Weatherization:** Is the weather stripping in good repair? Do storm windows fit tightly? Are the screens damaged?

### *Estimated Life Span and Repairs Required*

1. Windows should last 100 years or more.
2. Repaint every 5-8 years, as necessary depending on weathering.
3. Window glass should last indefinitely.
4. Paint every 5-8 years, depending on weathering.
5. Hardware, properly treated, should last indefinitely.
6. Putty should last 10-15 years.
7. Caulking should last 15-20 years.

## Exterior Features

*What to look for...*

- ❑ **Exterior elements:** Are porches, stairs, railings, cornices, brackets and other exterior features in good repair? Are elements missing?
- ❑ **Paint:** Is the paint cracked, faded, or peeling?

### *Estimated Life Span and Repairs Required*

1. Repaint every 5-10 years, depending on surface and conditions.

## Foundation

*What to look for...*

- ❑ **Masonry:** Does water drain away from the foundation? Is masonry flaking, crumbling, spalling, cracking? Is masonry loose or missing? Is the mortar secure?
- ❑ **Structure:** Is the wall bulging or bowing?
- ❑ **Vegetation:** Are algae, moss, vines growing on the foundation?
- ❑ **Water control:** Do downspouts have splash blocks?

### *Estimated Life Span and Repairs Required*

1. Properly maintained masonry should last indefinitely.
2. Pointing should last 50 years or more.

## The Economic Impact of Building Improvements

From *The Cast Iron Column*, Technical Brief of the Virginia Main Street Program, November 1995

By Kathleen Frazier, Frazier Associates

The next time a business owner in downtown asks: “What good will a facade improvement do for my business anyway?” You can confidently reply: “Increased sales.”

That’s right, folks. Several studies have been conducted that give the economic facts to what we have all known intuitively for some time: an improved exterior appearance improves the image of a downtown business; attracts more shoppers and increases sales.

In 1986, the University of Wisconsin-Extension conducted a study titled the Economic Effects of Storefront Improvement, and in 1990 Main Street West Virginia conducted a similar survey titled The Economic Impact of Storefront Improvements. In each study, interviews were conducted from a sampling of over 100 merchants in a total of 30 different communities (20 in Wisconsin and 10 in West Virginia). The studies found that:

- Roughly 70% of the businesses reported an increase in sales after making facade improvements.
- Roughly 85% of the businesses also made interior improvements including new inventory and product lines, merchandising and window display.
- A majority of improved buildings were owner occupied or locally owned.

- Costs for facade improvements ranged from \$500 to \$60,000 and included everything from signs to total restoration.
- Well over 90% of all participants were very pleased with the renovations and had experienced favorable comments from customers.

In West Virginia, the results also indicated that the majority of renters had no resulting rent increase after the building improvements.

“Wow!” you say. “But how much do sales increase, and are they just a flash in the pan, or are those increases sustained over time?” A former Main Street coordinator in Kansas, Brenda Spencer devoted her Master of Architecture thesis (1995) titled *An Analysis of the Economic Impact of Physical Improvements on Retail Sales*. She studied six downtown businesses that had made physical improvements and could provide actual cost and sales data before and after the improvements. In the previous studies only the opinions of business owners were used and actual numbers were not available.

Here is a summary of Spencer’s study:

- The scope of physical improvements included three common elements: storefronts, signs and/or awnings, and interior improvements.
- Most businesses were retail, with one service and one restaurant
- Facade improvements ranged from \$10,000 to 60,000, with over half being in the \$10,000-20,000 range. Typically, the facade improvement was 20-30% of total rehabilitation costs.

- The most common concurrent business improvement was of a physical nature - merchandise layout and displays
- All businesses experienced an increase in the annual percentage increase in gross sales the year after improvements - an average of 272%
- The majority of businesses sustained an increase in sales - an average increase of 222% in the average annual percentage increase in gross sales - after improvements.
- A majority experienced an increase in sales after improvements above their own business’s average before improvements, and above the performance of other local businesses for the same period.
- Two- thirds of the business owners stated that the physical improvement significantly impacted the increase in sales.
- All of the businesses experienced favorable customer response and considered the improvements worth the investment.

Main Street is economic development within the context of historic preservation and now the numbers are here to clearly show the impact of physical improvements on the success of downtown business.

