



Hop Air Fryer Pro Model: EFE475PRO

Hop Air Fryers deliver the quality your customers can see - improving profits and health at an affordable price.



Standard Features

- 2 International patents
- Digital Control panel
- Stackable (With optional stacking kit)
- Rotating Basket – 3.5lb capacity
- Condensation emission removal system
- Carbon filter for odor removal
- USB port – up to 99 menu items
- Self cleaning

Optional Accessories

- Cooking Grid GN 2/3 Part #EFE115P
- Teflon Cooking Tray Part #EFEPT50
- Stacking Kit Part #EFESK30
- Spray Down Hose Assembly Part #EFES1
- Carbon Filter Part #EFEGF1
- Stainless Steel Equipment Stand Part #EFESVET3630
- Stainless Steel Freezer Base Part #EFELBFD8230S

.....

Standard Items Included

- 2 Rotating stainless steel baskets
- 1 Teflon tray
- 2 Extractor Handles
- 1 Carbon filter

Weight & Size

- 115lbs.
- 27-3/4" x 31-3/4" x 21-7/8" (W X D X H)

Contact Us

Visit: EcoFryEquipmentllc.com

Email: kraymond@ecofryequipment.com

Hop Air Fryer Pro Model: EFE475PRO

POSITIONING THE DEVICE

Before positioning the appliance in the final installation location, it is crucial to read the information below and to view the overall dimensions, consulting the technical drawings dedicated to them.

HOP AIR - HOP AIR PRO - HOP AIR .P - HOP AIR PRO .P

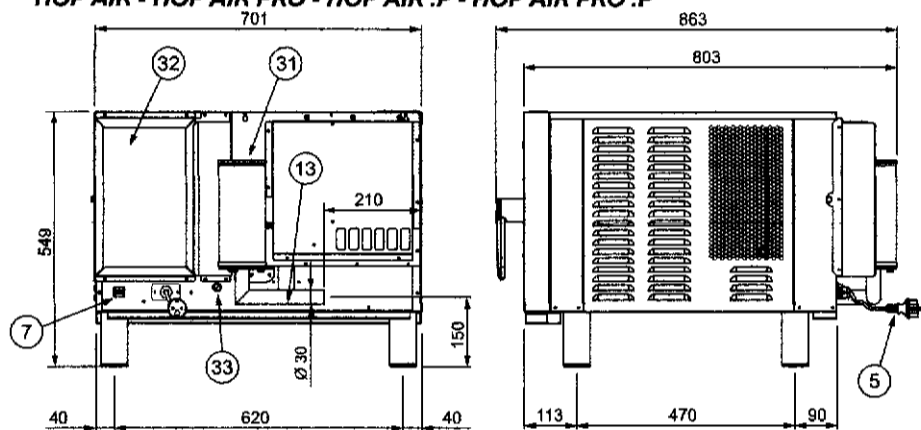

HOP - HOP .P

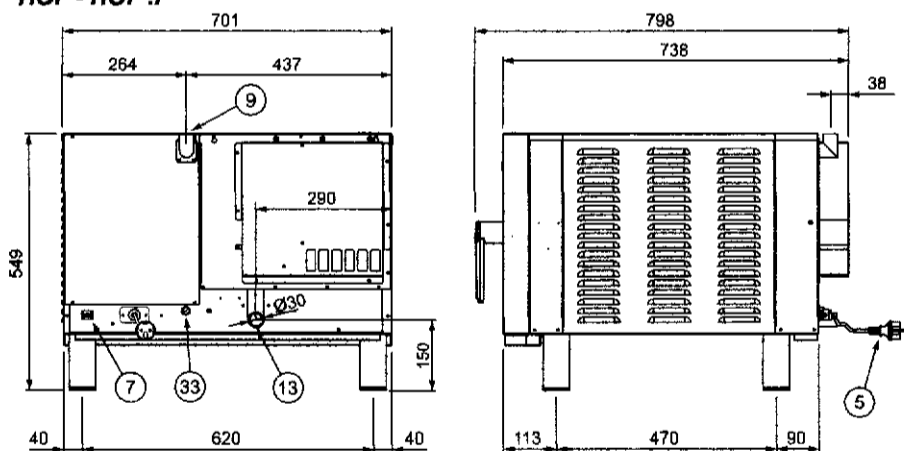

5	Power cable	31	Carbon filter
7	Equipotential terminal	32	Air filter
9	Smoke outlet flue	33	Safety thermostat
13	Drain pipe		

Power Requirements	208V-240V
Phase	Single
Amps	24
Breaker	30 Amp
KW	4.75
Plug	NEMA LP6-30
Receptacle	NEMA L6-30R
Clearences	4" L, R & Rear
Drain	1-1/8" Connection
Water Inlet	8mm OD Tubing
Water Pressure	1.8 - 2.5 bar

All connections must comply with federal, state and local codes.

Contact Us

Visit: EcoFryEquipmentllc.com

Email: kraymond@ecofryequipment.com