

bits & pieces quilting

Learn ▲ Create ▲ Share

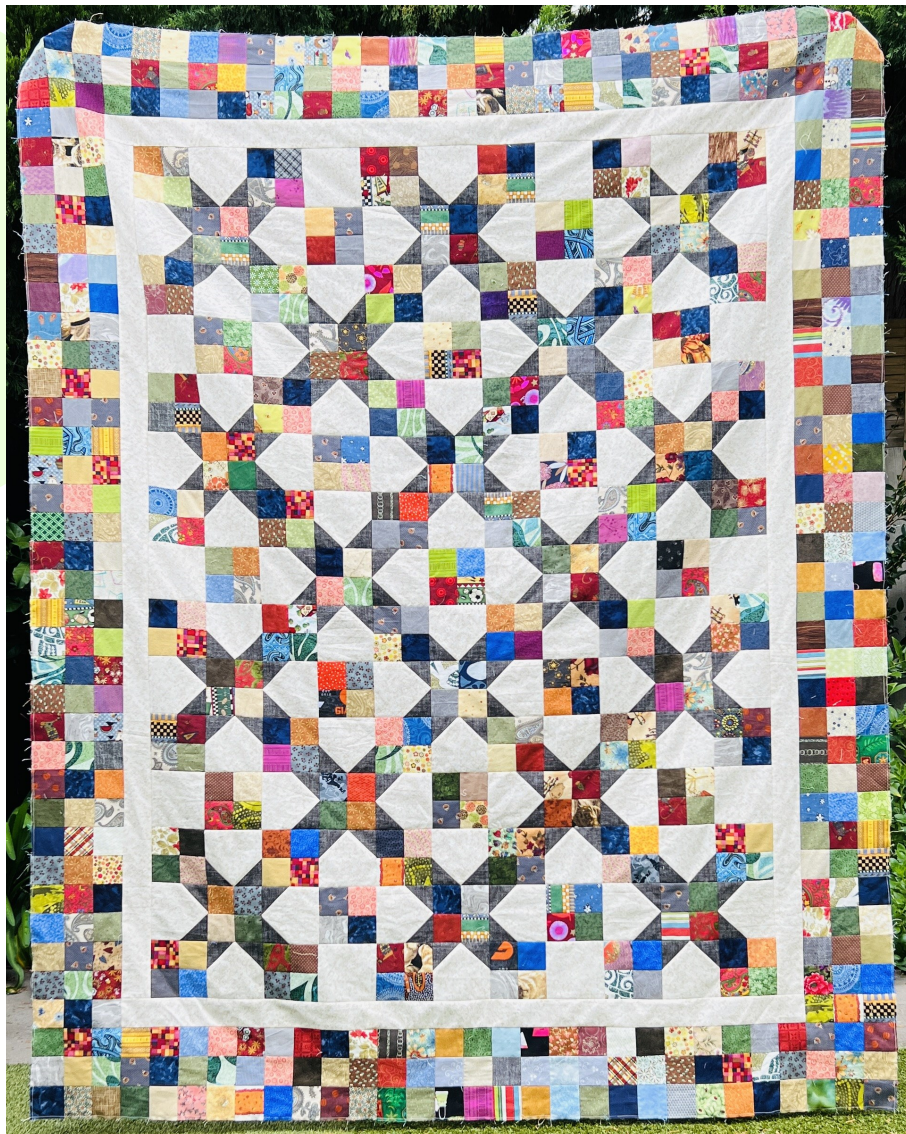

Four Patch Trellis

Throw Quilt: 60 x 76 inches

Copyright: Michelle Van Dyk, Bits & Pieces Quilting, 2024. All rights reserved.
Reproduction of this pattern for commercial use is strictly prohibited.

Fabric Requirements: (assuming 40 inches usable fabric from salvage to salvage)

Background Fabric: 1½ yards (1½ metres)

Patchwork including borders: 44 strips of fabric 2½ inches wide, or assorted scraps

Accent Fabric: 22½ inches or ¾ yard/metre

Binding: ½ yard (½ metre)



Cutting Instructions: (Note - read all instructions before you begin cutting)

Background Fabric:

- Cut 11 strips of fabric 4½ inches wide and cross cut these into 4½ x 4½ inch squares. You will need 82 for this project. If the amount of usable fabric is wider than 40 inches, you may be able to cut 9 squares from each strip (so require fewer strips). Measure the width of your fabric before cutting.

Scrappy Patchwork, including borders:

- You will need 372 squares that are 2½ x 2½ inches for the borders and 332 squares that are 2½ x 2½ inches for the centre patchwork (704 total). I recommend cutting these from your scraps.

Note: You could use a jelly roll for this project, but you will need to supplement it with a few additional pieces of fabric. A standard jelly roll is 40 strips and you can usually get 16 pieces from each strip for a total of 640 squares. Keep in mind that some strips in the jelly roll may be too light for this project, although you may wish to use those pieces in the borders.

Accent Fabric:

- Cut 9 strips of fabric 2½ inches wide and cross cut these into 2½ x 2½ inch squares. You will need 154 for this project.

Binding:

- Cut 7 strips at 2½ inches by width of fabric.

Assemble the Quilt

1. Begin by sewing the trellis units. This pattern uses the sew-and-flip method to add triangle corners to the background squares. Place one $2\frac{1}{2} \times 2\frac{1}{2}$ inch accent square, right sides together, on the corner of a $4\frac{1}{2} \times 4\frac{1}{2}$ inch background square. Sew along the diagonal as shown in the diagram below. Trim off the excess corner fabric approximately $\frac{1}{4}$ inch from the seam. Save this bonus piece! Details on how to make the bonus pieces into hourglass blocks can be found on page 6.

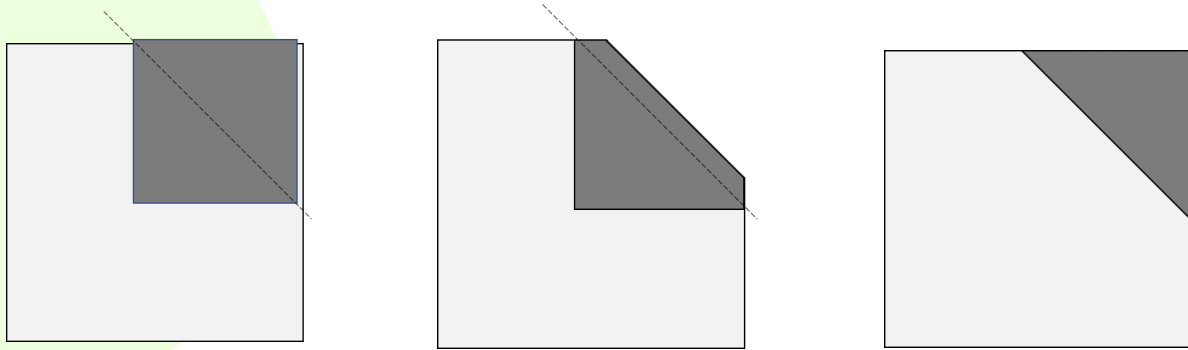

2. Repeat the same process for the second side of the trellis block as shown. You will need 72 for this project.

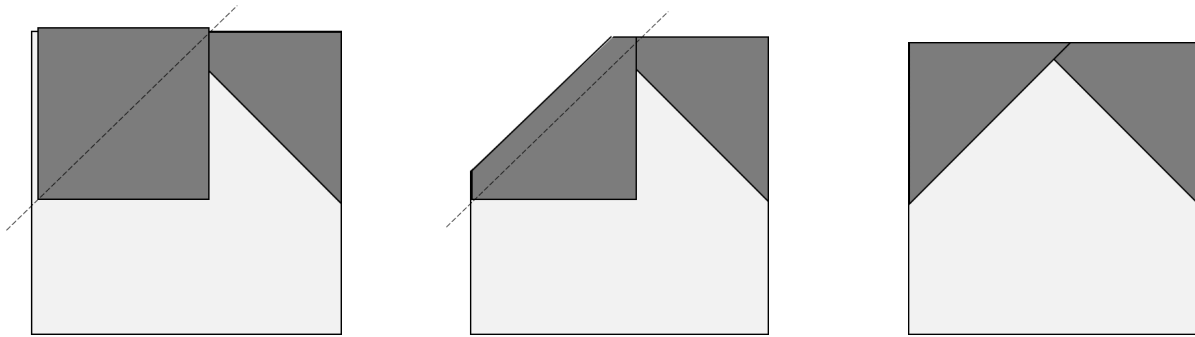

3. To make the four patch blocks, sew 166 of your $2\frac{1}{2} \times 2\frac{1}{2}$ inch squares together to make two patch units. Press the seams to one side. Then match up two of these units, nesting the seams to create four patch units. You will need 83 four patch units for this project.

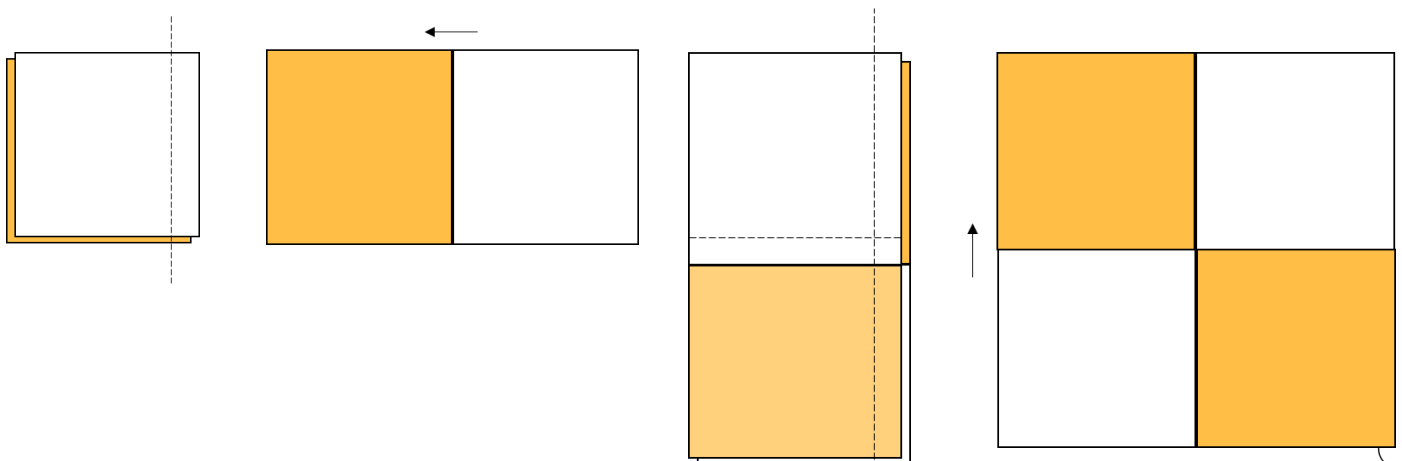

4. Lay out the quilt according to the diagram on page 5 noting where the trellis blocks are turned and where the 10 plain background squares are added to the design.
5. Sew the rows together and press. Add the 2½ inch inner border by measuring the long sides of the quilt and cutting border strips to fit. Pin and sew the long borders, then press. Then measure the top and bottom of the quilt and cut border strips to fit. Pin and sew the top and bottom borders, then press.
6. To make the pieced outer border, sew 372 2½ x 2½ inch squares into groups of three. Press the seams in each group of three in one direction. Sew together 32 groups of three to make the borders for the long sides and sew these to the quilt. Sew 30 groups of three for the top and bottom borders and add these to the quilt.
7. I recommend sewing a "victory lap" around the outside edge of your border. Sew a seam one-eighth of an inch from the edge as a basting stitch all the way around. This will prevent any seams from opening and will stabilize the edge.
8. Layer the completed quilt top with backing and batting and quilt as desired. Prepare the binding by sewing the 7 binding strips together end-to-end and pressing along the length of the binding with wrong sides together. Add binding to the quilt and don't forget to add a label.

I hope you enjoy this quilt! It is a great scrap buster project, but a unified background and accent fabric brings it all together. I love the scrappy border and it uses up a ton of those scraps from the 2½ inch drawer!

Share pictures of your Four Patch Trellis quilt with me on social media:



bitspiecesquilt

Tune in and subscribe to my YouTube channel for a complete tutorial on how to make the Four Patch Trellis quilt, as well as video on how I selected the scraps for this project. There are also lots of other interesting videos with quilting tips, tricks and tutorials.



bits & pieces quilting

Visit my website at: www.bitsandpiecesquilting.com

Quilt Diagram

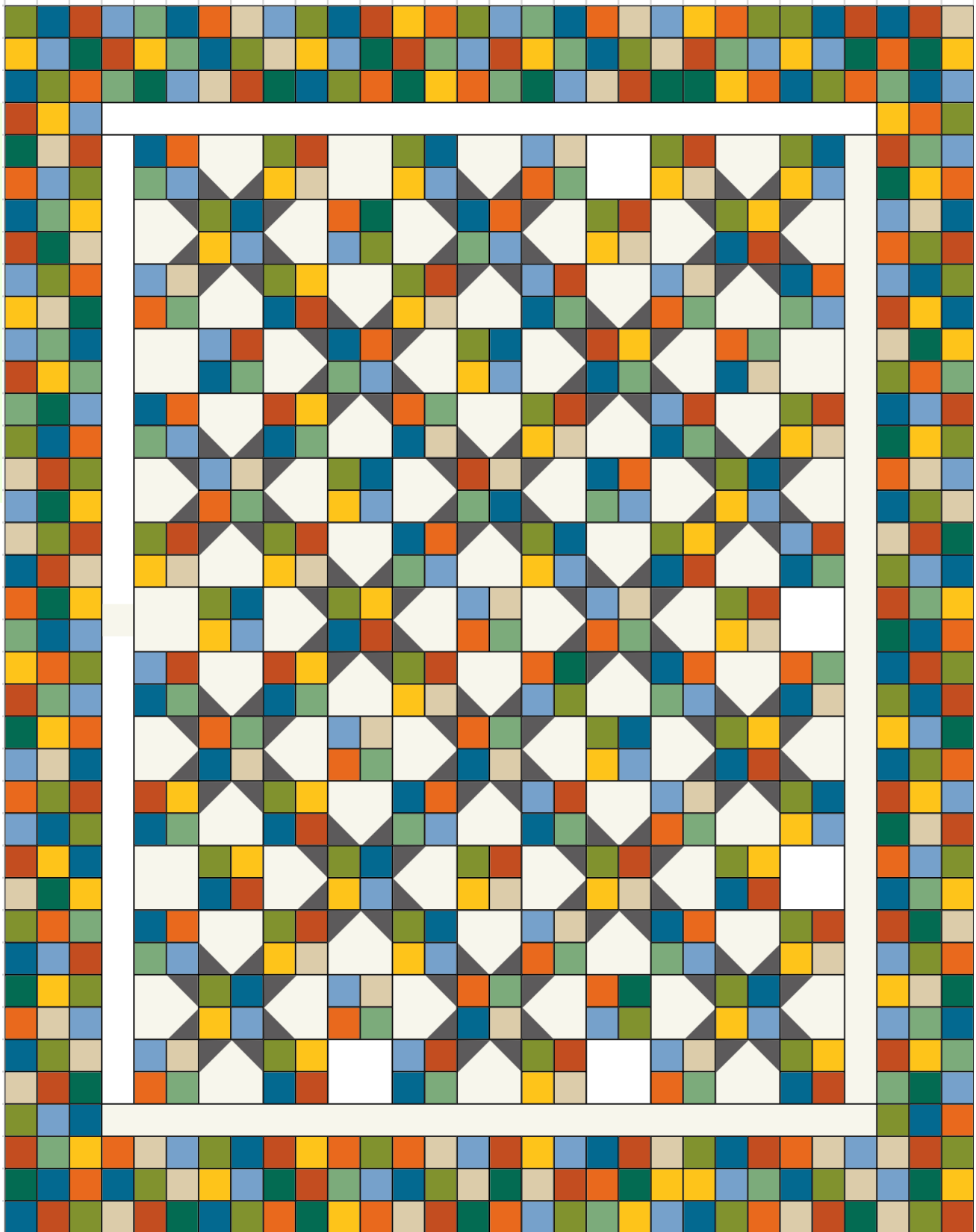

Quilt diagram designed in PreQuilt—see <https://prequilt.com>

Sewing the Bonus Pieces: Bits & Pieces from the Sew and Flip Method

1. Sew together the leftover sew-and-flip pieces as shown. Press seams as indicated towards the darker fabric.

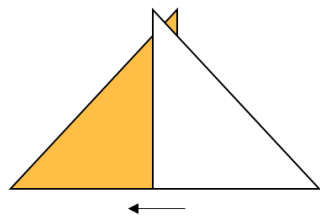
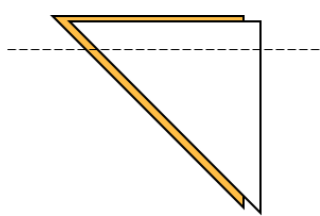

2. Sew two triangle units together to form the hourglass block. Because these units are leftover pieces, they maybe different sizes. Line up and nest the centre seams and don't worry about any size difference. The block will be trimmed in step 3.

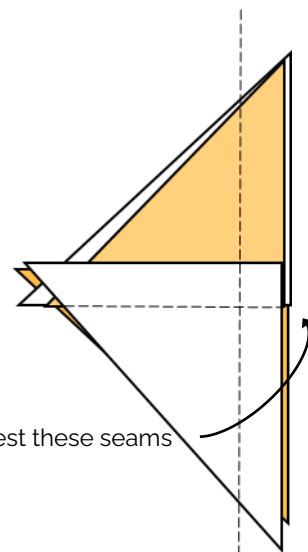

3. Press the hourglass block. I recommend pressing this seam open. Align a quilting ruler so the one inch line is on the centre of the block and the 45 degree line follows your diagonal seam. Square the block to 2 inches.

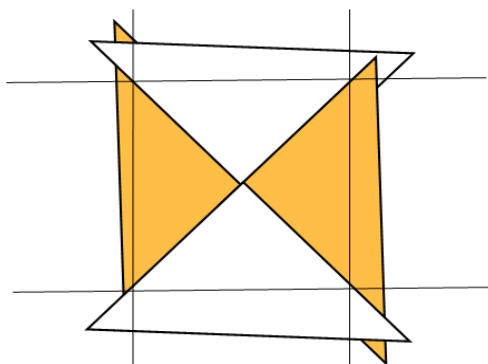
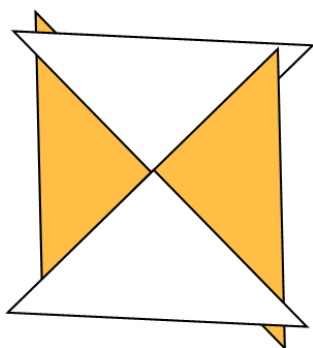

Square the block to 2 x 2

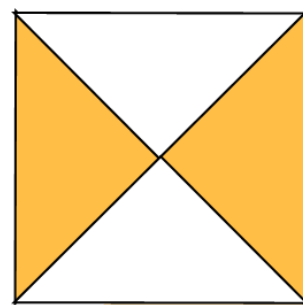

Final hourglass block

4. Save these blocks for a future project, or visit my website for various pattern ideas including the Square Dance Quilt, or Stars on Parade, or make a version of the quilt I usually use as my backdrop in my YouTube videos.