

Vector inverter for lifts with synchronous motors

SIEDrive



ADL300

■ ■ ■ ■ Functions description
and parameters list

GEFRAN

Information about this manual

This manual explains the functions and the description of the parameters.

The informations about mechanical installation, electrical connection and fast start-up can be found on the ADL300 Quick start guide.

The whole set of manuals can be found on the CD provided with the drive.

Software version

This manual is updated according the software version V V 4.0.0 .

Variation of the number replacing "X" have no influence on the functionality of the device.

The identification number of the software version is indicated on the identification plate of the drive or can be checked with the PAR 490 **Firmware ver.rel** parameter, menu 2.7.

General information

Note !

.....
In industry, the terms "Inverter", "Regulator" and "Drive" are sometimes interchanged. In this document, the term "Drive" will be used.
.....

Before using the product, read the safety instruction section carefully. Keep the manual in a safe place and available to engineering and installation personnel during the product functioning period.

Gefran S.p.A has the right to modify products, data and dimensions without notice. The data can only be used for the product description and they can not be understood as legally stated properties.

Thank you for choosing this Gefran product.

We will be glad to receive any possible information which could help us improving this manual.

The e-mail address is the following: techdoc@gefran.com.

All rights reserved.

Table of Contents

Information about this manual	2
Symbols used in the manual.....	4
A - Programming	5
A.1 Asynchronous/Synchronous selection.....	5
A.2 Menu display modes	5
A.3 Programming of “function block” analog and digital input signals	5
A.4 Variable interconnections mode	5
B - Parameters and functions description (Expert list)	7
Legend.....	7
1 - MONITOR	8
2 - DRIVE INFO	10
3 - STARTUP WIZARD	13
4 - DRIVE CONFIG	14
5 - LIFT	18
5.1 – SPEED	18
5.2 – RAMPS.....	20
5.3 – LIFT SEQUENCES.....	22
5.4 – MECHANICAL DATA	27
5.5 – DISTANCE.....	29
5.6 – EMERGENCY MODE	35
5.7 – INPUT/OUTPUT	37
5.8 –PRE - TORQUE	48
5.9 – LIFT ALARMS.....	50
6 -	53
7 -	53
8 -	53
9 -	53
10 - DIGITAL INPUTS	54
11 - DIGITAL OUTPUTS	55
12 - ANALOG INPUTS.....	56
13 - ANALOG OUTPUTS.....	59
14 - MOTOR DATA	61
15 - ENCODER CONFIG.....	64
16 - SPEED REG GAINS	69
17 - REGULATOR PARAM	73
18 - TORQUE CONFIG	74
19 - FUNCTIONS	76
19.1 - FUNCTIONS/INERTIA COMP.....	76
19.2 - FUNCTIONS/MOTOR OVERLOAD	76
19.3 - FUNCTIONS/BRES OVERLOAD	78
19.4 - FUNCTIONS/DOUBLE PAR SET.....	79
19.5 - FUNCTIONS/COMPARE	81
19.6 - FUNCTIONS/PADS	82
19.7 - FUNCTIONS/DIRECTION COUNT.....	83
20 - COMMUNICATION	86
20.1 - COMMUNICATION/RS232	86
20.2 - COMMUNICATION/FIELDBUS CONFIG	87
20.3 - COMMUNICATION/FIELDBUS M2S	88
20.4 - COMMUNICATION/FIELDBUS S2M	91
20.5 - COMMUNICATION/WORD COMP	93
20.6 - COMMUNICATION/WORD COMP	94
21 - ALARM CONFIG	95
23 - ALARM LOG	104
PARAMETERS ON SELECTION LISTS, BUT NOT DISPLAYED ON KEYPAD	105
C - SELECTION LISTS	109
L_ANOUT	109
L_CMP	109
L_DIGSEL1	109
L_DIGSEL2	110
L_DIGSEL3	110
L_FBS2M	110
L_LIM	111
L_MLTREF	111
L_REF	111
L_SCOPE	111
L_VREF	111
L_WDECOMP	111

D - Block Diagrams	113
System diagram index (Syn.).....	113
Drive overview (DrvOverview).....	113
ADL1 application index (ADL1FuncIndex).....	114
Expansion card digital inputs (DigImpExp).....	117
Expansion card digital outputs (DigOutExp).....	118
Analog input (AnInpExp).....	119
Analog output (AnOut).....	120
Encoder config.....	121
Functions.....	122
Torque control (TorqueCtrl).....	124
Gains adaptive (GainAdapt).....	124
Appendix - 1.0 CANopen interface	126
1.1 CANopen functions.....	126
1.2 CANopen management.....	129
1.3 Process Data Channel Control.....	130
1.4 SDO management.....	131
1.5 Alarms.....	133
1.6 Configuration example.....	134
Appendix - 2.0 Configuring the Drive to manage Peripheral Encoders	141

Symbols used in the manual



Warning

Indicates a procedure, condition, or statement that, if not strictly observed, could result in personal injury or death.

Indique le mode d'utilisation, la procédure et la condition d'exploitation. Si ces consignes ne sont pas strictement respectées, il y a des risques de blessures corporelles ou de mort.



Caution

Indicates a procedure, condition, or statement that, if not strictly observed, could result in damage to or destruction of equipment.

Indique et le mode d'utilisation, la procédure et la condition d'exploitation. Si ces consignes ne sont pas strictement respectées, il y a des risques de détérioration ou de destruction des appareils.



Indicates that the presence of electrostatic discharge could damage the appliance. When handling the boards, always wear a grounded bracelet.

Indique que la présence de décharges électrostatiques est susceptible d'endommager l'appareil. Toujours porter un bracelet de mise à la terre lors de la manipulation des cartes.



Attention

Indicates a procedure, condition, or statement that should be strictly followed in order to optimize these applications.

Indique le mode d'utilisation, la procédure et la condition d'exploitation. Ces consignes doivent être rigoureusement respectées pour optimiser ces applications.

Note !

Indicates an essential or important procedure, condition, or statement.

Indique un mode d'utilisation, de procédure et de condition d'exploitation essentiels ou importants.

A - Programming

A.1 Asynchronous/Synchronous selection

The ADL300 is factory-set to operate in asynchronous motor control mode.

To switch to the synchronous motor control mode, set PAR 6100 **Load synch control** (Menu 4 - DRIVE CONFIG). For information on switching control mode via keypad, reference should be made to the ADL300 Quick Start Guide (via integrated keypad, see paragraph 8.2.9; via optional keypad, see paragraph 8.3.15).

Note!

If asynchronous motor control is selected, use the ADL300 Description of functions and list of parameters – Vector inverter for lifts with asynchronous motors manual

A.2 Menu display modes

The programming menu can be displayed in two modes, which can be selected using the Access mode parameter (04 - DRIVE CONFIG menu):

- **Easy** (default) only the main parameters are displayed.
- **Expert** all the parameters are displayed.

A.3 Programming of “function block” analog and digital input signals

The signals, variables and parameters of each single “function block” of the drive are interconnected in order to achieve the configurations and controls inside the control system.

These can be managed and modified using the keypad, PC configurator or fieldbus programming.

The programming mode is based on the following logic:

- Src** (source; i.e.: **Ramp ref 1 src**, PAR: 610)
This term defines **the source of the function block input**, i.e. the signal to be processed in the function block.
The different configurations are defined in the relative **selection lists**.
- Mon** (display; i.e.: **Ramp ref 1 mon**, PAR: 620)
This term refers to the **variable output from the function block, which is the result of the calculations performed on the actual block**.

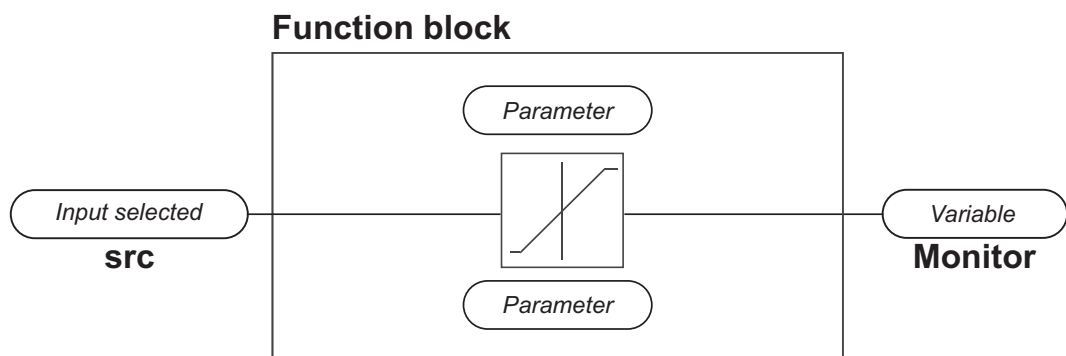

A.4 Variable interconnections mode

The **source (src)** allows the desired control signal to be assigned to the function block input. This operation is performed by using specific selection lists.

Possible control signal sources:

1 – Physical terminal

The analog and digital signals come from the terminal strip of the regulation card and/or from those of the expansion cards.

2 – Drive internal variables

Internal drive control system variables, from “function block” calculations, sent via keypad, PC configurator or fieldbus.

Practical example

The following examples illustrate the philosophies and methods with which more or less complex operations are performed in the single “function blocks”, the results of which represent the output of the block.

• Example: Changing the Speed Reference source

The main drive reference (in the default configuration) **Ramp ref 1 mon** (PAR: 620) is generated by the output of the function block “**Ramp setpoint Block**”.

Its default source is the **Analog input 1 mon** signal (PAR: 1500), from the output of the function block “**Analog input 1 Block**”, which in this case refers to analog input 1 of the signal terminal strip.

To change the reference source from the analog input to a digital reference inside the drive, the input signal must be changed to “**Ramp setpoint Block**”.

Enter the **Ramp ref 1 src** parameter (PAR: 610) and set a new reference, selecting it from among those listed in the L_ML-TREF selection list, for example **Dig ramp ref 1** (PAR: 600).

• Example: Inverting the analog reference signal

To invert the “**Analog input 1X Block**” output signal, the value of the **An inp 1X sign src** parameter (PAR: 1626), which has a default setting of Null (no operation), must be changed by selecting the source of the command signal from among those listed in the L_DIGSEL 2 selection list, for example **Digital input X mon, One** (function always enabled), etc.

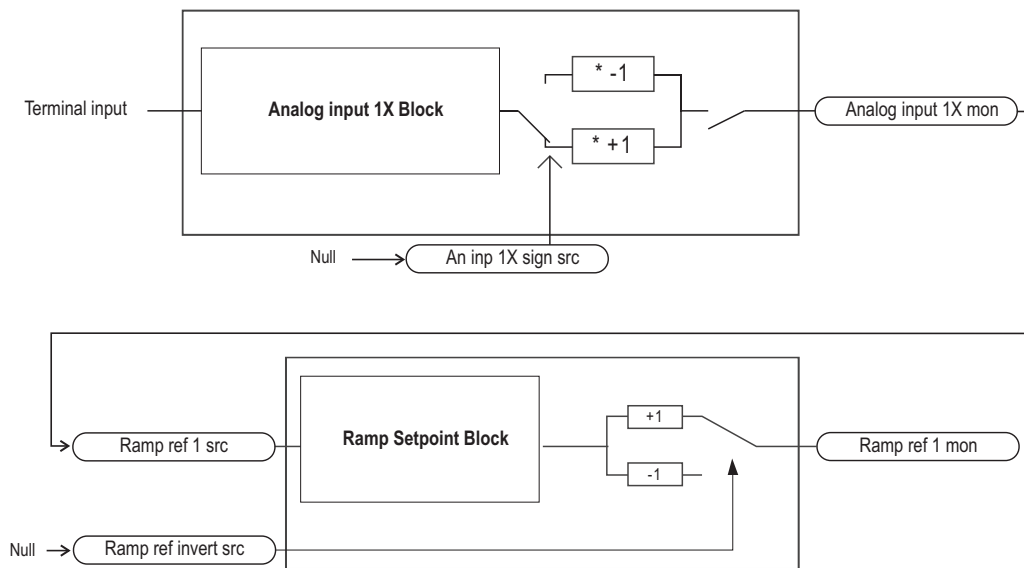

The diagrams above illustrate the internal processing philosophy of the single “function blocks” and the result of these changes on the other interconnected “function blocks”.

Note !

This section contains a brief description of the functions of the other parameters in the function blocks not included for the changes in the example.

The **Ramp ref invert src** parameter (PAR: 616) can be used to select the source for the command to reverse the “**Ramp setpoint**” function block output.

The output signal from the “**Ramp setpoint**” block is displayed in the **Ramp ref 1 mon** parameter (PAR: 620).

B - Parameters and functions description (Expert list)

Legend

0	1	2	3	4	5	6	7	8	9	10
Menu	PAR	Description	UM	Type	FB BIT	Def	Min	Max	Acc	Mod
1 - MONITOR						<i>(Level 1 menu)</i>				
1.1	250	Output current	A	FLOAT	16/32	0.0	0.0	0.0	R	F__
1.2	252	Output voltage	V	FLOAT	16/32	0.0	0.0	0.0	R	F__
21.5 - COMMUNICATION/WORD COMP						<i>(Level 2 menu)</i>				
21.5.1	4400	Word bit0 src		LINK	16BIT	6000	0	16384	ERW	F__
21.5.16	4430	Word bit15 src		LINK	16BIT	6000	0	16384	ERW	F__
				L_DIGSEL1		<i>(Selection List) [*]</i>				

0	Indexing of the menu and parameter	
1	Parameter identifier	
2	Parameter description	
3	UM: unit of measure	
4	<p>Type of parameter</p> <p>BIT Boolean, from modbus seen as 16 bits</p> <p>ENUM Selection list, from modbus seen as 16 bits</p> <p>FLOAT Real, from modbus seen as 32 bits</p> <p>INT16 Integer with sign 16 bits, from modbus seen as 16 bits</p> <p>INT32 Integer with sign 32 bits, from modbus seen as 32 bits</p> <p>ILINK Selection list, from modbus seen as 16 bits</p> <p>LINK Selection list, from modbus seen as 16 bits</p> <p>UINT16 Integer without sign 16 bits, from modbus seen as 16 bits</p> <p>UINT32 Integer without sign 32 bits, from modbus seen as 32 bits</p>	
5	Format of data exchanged on Fieldbus (16BIT, 32BIT)	
6	Default value	CALCF Value calculated as a number with floating point
7	Minimum value	CALCI Value calculated as a whole number
8	Maximum value	SIZE Value depending on the size of the drive

9	<p>Accessibility :</p> <p>E Expert</p> <p>R Read</p> <p>S Size (set value depending on the size of the device)</p> <p>W Write (scrittura)</p> <p>Z parameters that can be modified ONLY with the drive disabled</p>
10	<p>Available in regulation mode:</p> <p>V = V/f Control (open loop) / PM synchronous</p> <p>S = Vect Flux OL</p> <p>F = Vect Flux CL (closed loop)</p>
[*]	<p>Selection lists:</p> <p>The "Sorgente.../Sorg..." format parameters are linked to a selection list.</p> <p>The source of the signal that will control the parameter can be selected from the list indicated.</p> <p>The lists are indicated in paragraph C of this manual.</p>

1 - MONITOR

Menu	PAR	Description	UM	Type	FB BIT	Def	Min	Max	Acc	Mod
1.1	250	Output current	A	FLOAT	16/32BIT	0.0	0.0	0.0	R	F__

The drive output current is displayed.

Menu	PAR	Description	UM	Type	FB BIT	Def	Min	Max	Acc	Mod
1.2	252	Output voltage	V	FLOAT	16/32BIT	0.0	0.0	0.0	R	F__

The drive line voltage output is displayed.

Menu	PAR	Description	UM	Type	FB BIT	Def	Min	Max	Acc	Mod
1.3	254	Output frequency	Hz	FLOAT	16/32BIT	0.0	0.0	0.0	R	F__

The drive output frequency is displayed.

Menu	PAR	Description	UM	Type	FB BIT	Def	Min	Max	Acc	Mod
1.4	628	Ramp setpoint	rpm	INT16	16/32BIT	0	0	0	R	F__

The ramp reference is displayed. This is the speed value the drive must reach at the end of the ramp.

Menu	PAR	Description	UM	Type	FB BIT	Def	Min	Max	Acc	Mod
1.5	664	Speed setpoint	rpm	INT16	16/32BIT	0	0	0	R	F__

The speed reference is displayed. This is the value measured at the output of the speed reference circuit.

Menu	PAR	Description	UM	Type	FB BIT	Def	Min	Max	Acc	Mod
1.6	260	Motor speed	rpm	INT16	16/32BIT	0	0	0	R	F__

The actual output speed of the motor is displayed (in FOC = speed measured by the encoder, in SLS/VF = speed estimated by the drive).

Menu	PAR	Description	UM	Type	FB BIT	Def	Min	Max	Acc	Mod
1.7	270	DC link voltage	V	FLOAT	16/32BIT	0.0	0.0	0.0	ER	F__

The direct voltage of the intermediate circuit capacitors is displayed (DC-Bus).

Menu	PAR	Description	UM	Type	FB BIT	Def	Min	Max	Acc	Mod
1.8	272	Heatsink temperature	°C	INT16	16BIT	0	0	0	ER	F__

The temperature measured on the drive heatsink is displayed.

Menu	PAR	Description	UM	Type	FB BIT	Def	Min	Max	Acc	Mod
1.9	280	Torque current ref	A	FLOAT	16/32BIT	0.0	0.0	0.0	ER	F__

The current reference used for torque control is displayed (in the sensorless vector and field-oriented vector modes).

Menu	PAR	Description	UM	Type	FB BIT	Def	Min	Max	Acc	Mod
1.10	282	Magnet current ref	A	FLOAT	16/32BIT	0.0	0.0	0.0	ER	F__

The magnetizing current reference is displayed (in the sensorless vector and field-oriented vector modes).

Menu	PAR	Description	UM	Type	FB BIT	Def	Min	Max	Acc	Mod
1.11	284	Torque current	A	FLOAT	16/32BIT	0.0	0.0	0.0	ER	F__

The actual torque current value is displayed.

Menu	PAR	Description	UM	Type	FB BIT	Def	Min	Max	Acc	Mod
1.12	286	Magnet current	A	FLOAT	16/32BIT	0.0	0.0	0.0	ER	F__

The actual magnetizing current value is displayed.

Menu	PAR	Description	UM	Type	FB BIT	Def	Min	Max	Acc	Mod
1.13	3212	Motor overload accum		UINT16	16/32BIT	0	0	100	ER	F__

The motor overload level is displayed (100% = alarm threshold).

Menu	PAR	Description	UM	Type	FB BIT	Def	Min	Max	Acc	Mod
1.14	368	Drive overload accum		UINT16	16/32BIT	0	0	100	ER	F__

The drive overload level is displayed. An instantaneous overload of 200% of the drive rated current is allowed for 10s. The thermal image I²t adjusts the drive output current thresholds. During normal operation, the instantaneous output current value can reach 200% of the drive rated current. When the overload level par. 368 **Drive overload accum** reaches 100%, the output current threshold is reduced to 100% of the rated current, and stays at that value until the I²t integrator cycle is complete. At this point the instantaneous overload of 200% or 150% (below 3Hz) will be re-activated.

Menu	PAR	Description	UM	Type	FB BIT	Def	Min	Max	Acc	Mod
1.15	3260	Bres overload accum		UINT16	16/32BIT	0	0	100	ER	F__

The braking resistor overload limit is displayed (100% = alarm threshold).

Menu	PAR	Description	UM	Type	FB BIT	Def	Min	Max	Acc	Mod
1.16	1066	Enable state mon		BIT	16BIT	0	0	1	R	F__

The drive Enable command status is displayed. Voltage must be present on terminal 7. The FR Forwardstart command is needed to start the inverter.

1 Enabled drive enabled
0 Disabled drive disabled

Menu	PAR	Description	UM	Type	FB BIT	Def	Min	Max	Acc	Mod
1.17	1068	Start state mon		BIT	16BIT	0	0	1	R	F__

The drive **Start** command status is displayed.

Menu	PAR	Description	UM	Type	FB BIT	Def	Min	Max	Acc	Mod
1.18	1070	FastStop state mon		BIT	16BIT	0	0	1	R	F__

The drive FastStop command status is displayed.

Menu	PAR	Description	UM	Type	FB BIT	Def	Min	Max	Acc	Mod
1.19	1200	Digital input X mon		UINT16	16BIT	0	0	0	R	F__

The status of the digital inputs of the expansion card is displayed. It can also be read via a serial line or fieldbus. The data are contained in a word, where each bit is 1 if voltage is supplied to the corresponding input terminal.

1 Input enabled.
0 Input disabled.

Example:

0 0 0 0 0 0 0 0 0 0 0 0 0 0 0 0 1 1

Enable
DI 1

Menu	PAR	Description	UM	Type	FB BIT	Def	Min	Max	Acc	Mod
1.20	1400	Digital output X mon		UINT16		0	0	0	R	F__

The status of the digital outputs of the expansion card is displayed. It can also be read via a serial line or fieldbus. The data are contained in a word, where each bit is 1 if voltage is supplied to the corresponding input terminal.

1 Output enabled.
0 Output disabled.

Example:

0 0 0 0 0 0 0 0 0 0 0 0 0 0 0 0 1 1

DO 1
DO 2

2 - DRIVE INFO

This menu displays the information for identifying and configuring the drive.

Menu	PAR	Description	UM	Type	FB BIT	Def	Min	Max	Acc	Mod
2.1	476	Drive type		ENUM		Basic-Sin	1	0	R	FVS

The drive series identification code is displayed.

The drives reporting 24V in the description can be fed by an external 24Vdc power supply. For schematics and connection diagrams please refer to Quick Start manual.

- 0 Basic-Sin
- 1 Advanced
- 2 Basic-VGA
- 3 Basic-End
- 128 Basic-Sin 24V
- 129 Advanced 24V
- 130 Basic-VGA 24V
- 131 Basic-End 24V

Menu	PAR	Description	UM	Type	FB BIT	Def	Min	Max	Acc	Mod
2.2	480	Control type		ENUM		S1ynchronous	0	0	R	FVS

The control mode is displayed.

- 11 Asynchronous
- 12 Synchronous

Menu	PAR	Description	UM	Type	FB BIT	Def	Min	Max	Acc	Mod
2.3	482	Drive size		UINT16		0	0	0	RS	F__

The drive size identification code is displayed.

Menu	PAR	Description	UM	Type	FB BIT	Def	Min	Max	Acc	Mod
2.4	484	Drive family		ENUM		No Power	0	0	RS	F__

The available mains voltage is displayed (e.g. 400V). The undervoltage alarm refers to this voltage value.

The condition **No power** occurs when the regulation board has just left from production and has never been configured for any power. The configuration adjustment for a given power is achieved by linking it to a power board and running a **Save parameters**.

- 0 No Power
- 1 230V..480V
- 2 500V..575V
- 3 690V
- 4 230V

Menu	PAR	Description	UM	Type	FB BIT	Def	Min	Max	Acc	Mod
2.5	486	Drive region		ENUM		EU	0	1	R	F__

Setting of the geographical area in which the drive is to be used (Europe or USA). This setting determines the factory voltage and power supply frequency values.

- 0 EU (400V / 50Hz)
- 1 USA (460 / 60 Hz)

Menu	PAR	Description	UM	Type	FB BIT	Def	Min	Max	Acc	Mod
2.6	488	Drive cont current	A	FLOAT		CALCF	0.0	0.0	RZS	F__

The current that the drive can deliver continuously according to size, supply voltage and programmed switching frequency is displayed.

Menu	PAR	Description	UM	Type	FB BIT	Def	Min	Max	Acc	Mod
2.7	490	Firmware ver.rel		UINT16		0	0	0	R	F__

The version number and release number of the drive firmware are displayed. On the keypad these are displayed in the version.release format. The parameter reading from the serial communication device or fieldbus returns the version in the high byte and the release in the low byte.

Menu	PAR	Description	UM	Type	FB BIT	Def	Min	Max	Acc	Mod
2.8	496	Firmware type		UINT16		0	0	0	R	F__
		Identifies the version of the special firmware installed in the drive								
Menu	PAR	Description	UM	Type	FB BIT	Def	Min	Max	Acc	Mod
2.9	504	Application ver.rel		UINT16		0	0	0	ER	F__
		The version and release number of the application used in the drive are displayed. On the keypad these are displayed in version.release format. When the parameter is read via serial line or fieldbus the version is returned in the high byte and the release in the low byte.								
Menu	PAR	Description	UM	Type	FB BIT	Def	Min	Max	Acc	Mod
2.10	506	Application type		UINT16		0	0	0	ER	F__
		The type of application currently used by the drive is displayed.								
		6 EFC (Creep to Floor) 10 EPC (Direct Approach) 11 DCP3/DCP4 21 DS417 (CANOpen Lift CiA 417)								
Menu	PAR	Description	UM	Type	FB BIT	Def	Min	Max	Acc	Mod
2.11	508	Application subver		UINT16		0	0	0	ER	FVS
		The sub-version of the application displayed by parameter 506 is reported.								
Menu	PAR	Description	UM	Type	FB BIT	Def	Min	Max	Acc	Mod
2.12	510	Time drive power on	h.min	UINT32		0	0.0	0.0	ER	F__
		The total time for which the drive has been powered is displayed.								
Menu	PAR	Description	UM	Type	FB BIT	Def	Min	Max	Acc	Mod
2.13	512	Time drive enable	h.min	UINT32		0	0.0	0.0	ER	F__
		The time for which the enable hardware contact on the drive has been connected is displayed.								
Menu	PAR	Description	UM	Type	FB BIT	Def	Min	Max	Acc	Mod
2.14	514	Number power up		UINT16		0	0	0	ER	F__
		The number of times the drive has been powered on is displayed.								
Menu	PAR	Description	UM	Type	FB BIT	Def	Min	Max	Acc	Mod
2.15	516	Time fan on	h.min	UINT32		0	0.0	0.0	ER	F__
		The total time for which the drive fan has been running is displayed.								
Menu	PAR	Description	UM	Type	FB BIT	Def	Min	Max	Acc	Mod
2.16	520	Product S/N		UINT32		0	0	0	R	F__
		The drive serial number is displayed.								
Menu	PAR	Description	UM	Type	FB BIT	Def	Min	Max	Acc	Mod
2.17	522	Regulation S/N		UINT32		0	0	0	R	F__
		The drive regulation card serial number is displayed.								
Menu	PAR	Description	UM	Type	FB BIT	Def	Min	Max	Acc	Mod
2.18	524	Power S/N		UINT32		0	0	0	R	F__
		The drive power card serial number is displayed.								
Menu	PAR	Description	UM	Type	FB BIT	Def	Min	Max	Acc	Mod
2.19	526	Power file ver.rel		UINT16		0	0	0	ER	F__
		The drive power card configuration release is displayed.								

Menu	PAR	Description	UM	Type	FB BIT	Def	Min	Max	Acc	Mod
2.20	530	Slot 1 card type		ENUM		None	0	0	R	F__
2.21	532	Slot 2 card type		ENUM		None	0	0	R	F__
2.22	534	Slot 3 card type		ENUM		None	0	0	R	F__

The type of expansion card installed in the relative slot of the drive is displayed.

- 0 None
- 257 I/O 1
- 1281 I/O 2
- 2305 I/O 3
- 3841 I/O 4
- 4865 I/O 5
- 5377 I/O 6
- 8 Enc 1
- 264 Enc 2
- 520 Enc 3
- 776 Enc 4
- 1032 Enc 5
- 4 Can/Dnet
- 260 Profibus
- 516 Gdnet
- 255 Unknown
- 1544 Enc 4 Dbss

Note!

See Appendix to the Quick start guide for further information on the expansion cards.

SLOT 3 indicates the presence of the CAN on the regulation card in versions ADL300-...-C

Menu	PAR	Description	UM	Type	FB BIT	Def	Min	Max	Acc	Mod
2.23	536	Slot 1 card S/N		UINT32		0	0	0	R	F__
2.24	538	Slot 2 card S/N		UINT32		0	0	0	R	F__
2.25	540	Slot 3 card S/N		UINT32		0	0	0	R	F__

The serial number of the expansion card installed in the relative slot of the drive is displayed.

Menu	PAR	Description	UM	Type	FB BIT	Def	Min	Max	Acc	Mod
2.26	546	Fw encoder ver.rel		UINT16		0	0	0	R	F__

The version and release number of the encoder firmware used in the drive are displayed. On the keypad these are displayed in version.release format. When the parameter is read via serial line or fieldbus the version is returned in the high byte and the release in the low byte.

Menu	PAR	Description	UM	Type	FB BIT	Def	Min	Max	Acc	Mod
2.27	548	Fw encoder type		UINT16		0	0	0	R	F__

The type of firmware installed in the encoder is displayed.

3 - STARTUP WIZARD

The startup wizard menu suggests a procedure for commissioning the drive quickly with a reduced number of settings. Advanced customization requires the use of the single parameters relating to the specific performance levels. Refer to the procedure described in chapter 9 **Commissioning via keypad** in the Quick start-up guide.

4 - DRIVE CONFIG

Menu	PAR	Description	UM	Type	FB BIT	Def	Min	Max	Acc	Mod
4.1	550	Save parameters		BIT		0	0	1	RW	F__

Any changes to parameter values immediately affect drive operations, but are not automatically saved in the permanent memory. The "Save Parameters" command is used to save current parameter values in the permanent memory.

Any changes that are not saved will be lost when the drive is switched off.

To save parameters follow the procedure described in STEP 9 of the **Startup wizard**.

Menu	PAR	Description	UM	Type	FB BIT	Def	Min	Max	Acc	Mod
4.2	552	Regulation mode		ENUM		Flux vector CL	0	3	RWZ	F__

The ADL300 is capable of operating with different control modes:

2 Flux vector CL (Synchronous with permanent magnets)

3 Autotune

In the **field oriented vector mode (Flux vector CL/ Synchronous)** an encoder is required for closed loop feedback. With this mode it is possible to achieve extremely high dynamic responses thanks to the regulation bandwidth, maximum torque even with the rotor blocked, speed and torque control. Numerous regulation parameters can be used to adjust the drive to each specific application, for instance adaptive gains, system inertia compensation, etc..

If the **Startup wizard** procedure is not used, self-tuning of the motor parameters is possible in the **self-tuning mode (Autotune)**.

This procedure must be used for both self-tuning with the engine standing still and with the motor turning.

Menu	PAR	Description	UM	Type	FB BIT	Def	Min	Max	Acc	Mod
4.3	554	Access mode		ENUM		Easy	0	1	RW	F__

0 Easy

1 Expert

The **Easy** mode gives access to a list of parameters that can be used for rapid drive commissioning. This type of configuration is suitable for the majority of applications.

Setting the parameter to **Expert** gives access to all the parameters in the firmware. This mode allows an extremely high level of customization to be achieved in order to exploit the potential of the ADL300 to the full.

On fw 4.0.0 the change from Easy to Expert can be protected by a dedicated password (PAR 566 **Passwd expert**). This function is available only via keypad and not via Gefran_eXpress.

Menù	PAR	Descripción	UM	Tipo	FB BIT	Def	Min	Max	Acc	Mod
4.4	566	Passwd expert		UINT32		0	0	99999	RW	FVS

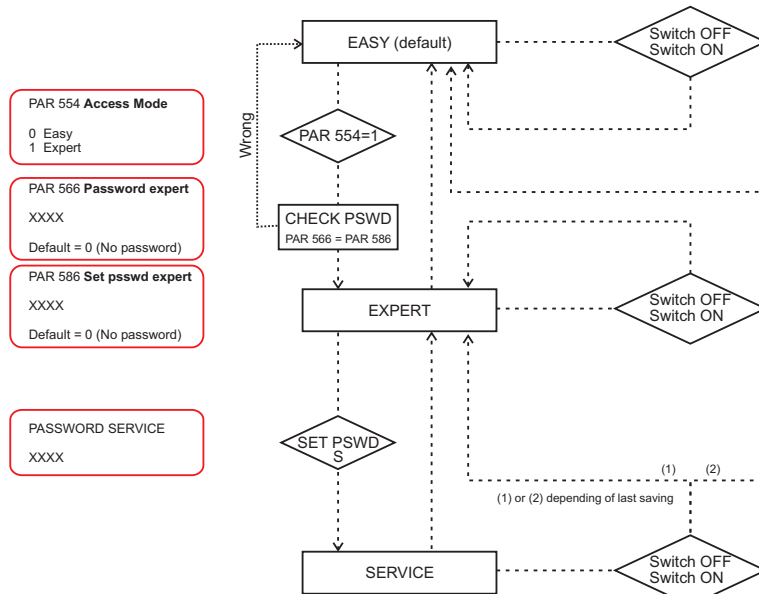

Type the password to enable parameter 554 **Access mode**.

The password must have been entered via parameter 586 **Set passwd expert**.

Menù	PAR	Descripción	UM	Tipo	FB BIT	Def	Min	Max	Acc	Mod
4.5		Reserved								

Menu	PAR	Description	UM	Type	FB BIT	Def	Min	Max	Acc	Mod
4.6	558	Application select		ENUM		Application 1	0	2	ERWZ	F__

Selection of which IEC 61131-3-compliant application to make operational.

- 0 None
- 1 Application 1
- 2 Application 2

The drive is supplied already incorporating a number of applications developed in the IEC 61331-3 environment. To use these, configure the desired application, run save parameter, switch the drive off and then on again. In the default configuration the drive starts with the EFC lift application (see menu 5 - LIFT for the description of this application).

Note! The **Load Default** command (par. 580) does not modify this parameter

Menu	PAR	Description	UM	Type	FB BIT	Def	Min	Max	Acc	Mod
4.7	560	Mains voltage	V	ENUM		400 V	SIZE	SIZE	ERWZS	F__

Setting of the available mains voltage value in Volts. Detection of the undervoltage alarm refers to this value.

- 0 200 V
- 1 230 V
- 2 380 V
- 3 400 V
- 4 415 V
- 5 440 V
- 6 460 V
- 7 480 V
- 8 575 V
- 9 690 V

Menu	PAR	Description	UM	Type	FB BIT	Def	Min	Max	Acc	Mod
4.8	448	Emergency UV	V	FLOAT		CALCF	0.0	CALCF	ERWZ	FVS

This parameter enables for the undervoltage threshold to be configured on the DC link. This parameter prevents the drive from opening the brake in emergency conditions without a DC link being supplied correctly.

Menu	PAR	Description	UM	Type	FB BIT	Def	Min	Max	Acc	Mod
4.9	450	Undervoltage	V	FLOAT		CALCF	CALCF	CALCF	ERWZS	FVS

Lets you change the Undervoltage value. Minimum and maximum default values depend on line voltage.

Menu	PAR	Description	UM	Type	FB BIT	Def	Min	Max	Acc	Mod
4.10	454	Chopper ON	V	FLOAT		CALCF	CALCF	CALCF	ERWZS	FVS

Corresponding to the threshold of activation of the braking resistor. It is so possible to increase this value just below the **Overvoltage** threshold level (ADL300-...-4 = 802 Vdc, ADL300-...-2T = 396 Vdc, ADL300-...-2M = 396 Vdc).

Parameter's range are defined thru IPA 560 **Mains voltage** setting.

Note! If **Mains voltage** is set at the maximum possible value, the activation threshold of the braking resistor can only assume the max value and can not be changed.

Menu	PAR	Description	UM	Type	FB BIT	Def	Min	Max	Acc	Mod
4.11	570	Password		UINT32		0	0	99999	ERW	F__

You can enter a **password** to protect the parameters from unauthorized tampering: the password can consist of a combination of a maximum of any 5 figures that can be selected by the user. All parameters are locked, except this one and **Save parameters**.

Entering the password, press the E key, then enter the password and press the E key again to enable it (a password enabled message (**Enabled**) is displayed).

So that the password remains valid even after switching the unit off and then switching it back on, save it using the **Save parameters** command.

When the password is enabled any attempts to modify a parameter are blocked and the **Password enabled** message is displayed.

To disable the password, enter the **Password** parameter (**570**) in the **DRIVE CONFIG** menu.

Check that the password is enabled (**Enabled**), press E and enter the combination of figures that make up the password.

Press E again. A message is displayed telling you the password is no longer enabled (**Disabled**).

To make sure the password continues to be disabled even after switching the unit off and then switching it back on, save this configuration using the **Save parameters** command.

When an incorrect password is entered, the Password wrong message is displayed.

Menu	PAR	Description	UM	Type	FB BIT	Def	Min	Max	Acc	Mod
4.12	572	Application key		UINT32		0	0	4294967295	ERW	F__

This parameter can be used to enter the key for enabling the PLC application.

You may need to enter a key to definitively enable some PLC applications. Please contact Gefran for details about which PLC applications require the key.

If executing an application that envisages a key verification and the key is incorrect, enabling is forced for 200 hours (time drive enabled).

In this phase a message is displayed informing you that the period of forced enabling time is about to expire.

At the first power-on after the 200 hours an alarm is generated and the application does not start.

Please contact Gefran for the numerical value of the key.

Menu	PAR	Description	UM	Type	FB BIT	Def	Min	Max	Acc	Mod
4.13	586	Set passwd expert		UINT32		0	0	99999	ERW	FVS

Enables the password to protect change of the setting of parameter 554 **Access mode** from **Easy** to **Expert**. A value other than 0 must be entered. Entering 0 disables the password.

You have to enter **Expert** mode to access parameter 586 **Set passwd expert**.

The password value must be entered twice to be accepted.

After the password is set, parameter 554 **Access mode** remains in **Expert** mode; to enable the protection, enter the password in parameter 566 **Passwd expert**.

Now parameter 554 **Access mode** will go to **Easy** mode. At every power-on, the drive will start in Easy mode with the protection enabled.

Menu	PAR	Description	UM	Type	FB BIT	Def	Min	Max	Acc	Mod
4.14	574	Startup display		INT16		-1	-1	20000	ERW	F__

It is possible to set the parameter that will automatically be displayed when the drive is switched on.

If set to -1 the main menu is automatically displayed when the drive is turned on.

If set to 0 the display page is automatically displayed when the drive is turned on.

Menu	PAR	Description	UM	Type	FB BIT	Def	Min	Max	Acc	Mod
4.15	576	Display backlight		BIT		0	0	1	ERW	F__

Enabling of the backlight on the drive display.

If set to 0 the display backlight will go off when the drive has been on for three minutes.

If set to 1 the backlight will stay on for as long as the drive is powered.

Menu	PAR	Description	UM	Type	FB BIT	Def	Min	Max	Acc	Mod
4.16	578	Language select		ENUM		English	0	4	RWZ	F__

Setting of the drive programming language.

- 0 English
- 1 Italian
- 2 French
- 3 German
- 4 Spanish
- 8 Turkish

Note!

The **Load Default** command (par. 580) does not modify this parameter.

Menu	PAR	Description	UM	Type	FB BIT	Def	Min	Max	Acc	Mod
4.17	580	Load default		BIT		0	0	1	RWZ	F__
Transfers the standard factory settings to the drive memory ("Def" column in the parameters table).										

Menu	PAR	Description	UM	Type	FB BIT	Def	Min	Max	Acc	Mod
4.18	590	Save par to keypad		BIT		0	0	1	RW	F__
Transfers the parameters currently stored in the drive and saves them in the keypad memory (See ADL300 Quick Start manual, chapter 8.3.13).										

Menu	PAR	Description	UM	Type	FB BIT	Def	Min	Max	Acc	Mod
4.19	592	Load par from keypad		BIT		0	0	1	RWZ	F__
Transfers the parameters from the keypad memory to the drive (See ADL300 Quick Start manual, chapter 8.3.13).										

Menu	PAR	Description	UM	Type	FB BIT	Def	Min	Max	Acc	Mod
4.20	594	Keypad memory select		UINT16		1	1	5	ERW	F__
Selection of the area of the keypad memory to which to transfer and save the parameters stored in the drive.										

Menu	PAR	Description	UM	Type	FB BIT	Def	Min	Max	Acc	Mod
4.21	596	Save to SD card		BIT		0	0	1	RW	F__
Transfers the drive parameters to the SD memory card (See chapter 8.3.14 of the Quick start-up guide).										

Menu	PAR	Description	UM	Type	FB BIT	Def	Min	Max	Acc	Mod
4.22	598	Load from SD card		BIT		0	0	1	RWZ	F__
Transfers the parameters from the SD memory card to the drive (See chapter 8.3.14 of the Quick start-up guide).										

Menu	PAR	Description	UM	Type	FB BIT	Def	Min	Max	Acc	Mod
4.23	6100	Load asynch control		BIT		0	0	1	ERW	FVS
Select the Asynchronous motor control mode. The drive is reset and restarts in the new control mode. To perform this operation via keypad, see chapters 8.2.9 and 8.2.15 of the ADL 300 Quick Start Guide.										

|||||

Note! Important: the default parameters including the LIFT application are reloaded.
This can only be done with the drive disabled.

|||||

5 - LIFT

5.1 – SPEED

Menu	PAR	Description	UM	Type	FB BIT	Def	Min	Max	Acc	Mod
5.1.1	11002	Travel units sel	m/s	ENUM		0	0	2	RW	F__

Selection of the unit of measure for speed references.

- 1 m/s (cabin speed and depends on the mechanical constant)
- 2 Rpm (speed of the motor shaft)
- 3 USCS (US units: fpm, ft/s², ft/s³)

When the unit of measure is modified the conversion constants are re-calculated, the units of measure are changed in the parameter list and the multispeed values are converted into the new unit of measure (the result may contain approximations due to the conversion calculations).

A variable representing the speed of the cabin in m/s (fpm) is always available (PAR 12210).

There are fixed units of measure for the acceleration and deceleration parameters m/s² (ft/s²), and for jerks m/s³ (ft/s³).

Menu	PAR	Description	UM	Type	FB BIT	Def	Min	Max	Acc	Mod
5.1.2	11020	Multi speed 0	m/s	FLOAT		0.10	-10000	10000	RW	F__

Setting of the multispeed 0 value. Can be selected via digital input, fieldbus, etc.

The selected value is the reference for the S-shaped lift ramp.

This setting is taken as the default low speed value.

Menu	PAR	Description	UM	Type	FB BIT	Def	Min	Max	Acc	Mod
5.1.3	11022	Multi speed 1	m/s	FLOAT		1.00	-10000	10000	RW	F__

Setting of the multispeed 1 value. Can be selected via digital input, fieldbus, etc.

The selected value is the reference for the S-shaped lift ramp.

This setting is taken as the default high speed value.

Menu	PAR	Description	UM	Type	FB BIT	Def	Min	Max	Acc	Mod
5.1.4	11024	Multi speed 2	m/s	FLOAT		0.40	-10000	10000	RW	F__

Setting of the multispeed 2 value. Can be selected via digital input, fieldbus, etc.

The selected value is the reference for the S-shaped lift ramp.

This setting is taken as the default maintenance speed value.

Menu	PAR	Description	UM	Type	FB BIT	Def	Min	Max	Acc	Mod
5.1.5	11026	Multi speed 3	m/s	FLOAT		0.00	-10000	10000	RW	F__

Setting of the multispeed 3 value. Can be selected via digital input, fieldbus, etc.

The selected value is the reference for the S-shaped lift ramp.

Menu	PAR	Description	UM	Type	FB BIT	Def	Min	Max	Acc	Mod
5.1.6	11028	Multi speed 4	m/s	FLOAT		0.00	-10000	10000	RW	F__

Setting of the multispeed 4 value. Can be selected via digital input, fieldbus, etc.

The selected value is the reference for the S-shaped lift ramp.

Menu	PAR	Description	UM	Type	FB BIT	Def	Min	Max	Acc	Mod
5.1.7	11030	Multi speed 5	m/s	FLOAT		0.00	-10000	10000	RW	F__

Setting of the multispeed 5 value. Can be selected via digital input, fieldbus, etc.

The selected value is the reference for the S-shaped lift ramp.

Menu	PAR	Description	UM	Type	FB BIT	Def	Min	Max	Acc	Mod
5.1.8	11032	Multi speed 6	m/s	FLOAT		0.00	-10000	10000	RW	F__

Setting of the multispeed 6 value. Can be selected via digital input, fieldbus, etc.

The selected value is the reference for the S-shaped lift ramp.

Menu	PAR	Description	UM	Type	FB BIT	Def	Min	Max	Acc	Mod
5.1.9	11034	Multi speed 7	m/s	FLOAT		0.00	-10000	10000	RW	F__

Setting of the multispeed 7 value. Can be selected via digital input, fieldbus, etc.
The selected value is the reference for the S-shaped lift ramp.

Menu	PAR	Description	UM	Type	FB BIT	Def	Min	Max	Acc	Mod
5.1.10	12010	Actual multi spd sel		ENUM					R	F__

The currently selected speed is displayed.

- 0 Multi speed 0
- 1 Multi speed 1
- 2 Multi speed 2
- 3 Multi speed 3
- 4 Multi speed 4
- 5 Multi speed 5
- 6 Multi speed 6
- 7 Multi speed 7
- 8 Null

Menu	PAR	Description	UM	Type	FB BIT	Def	Min	Max	Acc	Mod
5.1.11	12210	Actual speed ref	m/s	FLOAT					R	F__

The speed of the cabin is displayed in m/s.

5.2 – RAMPS

The lift application envisages an S-shaped ramp function with the possibility of setting 4 independent jerks and linear acceleration and deceleration factors, as in the standard profile illustrated in the figure below.

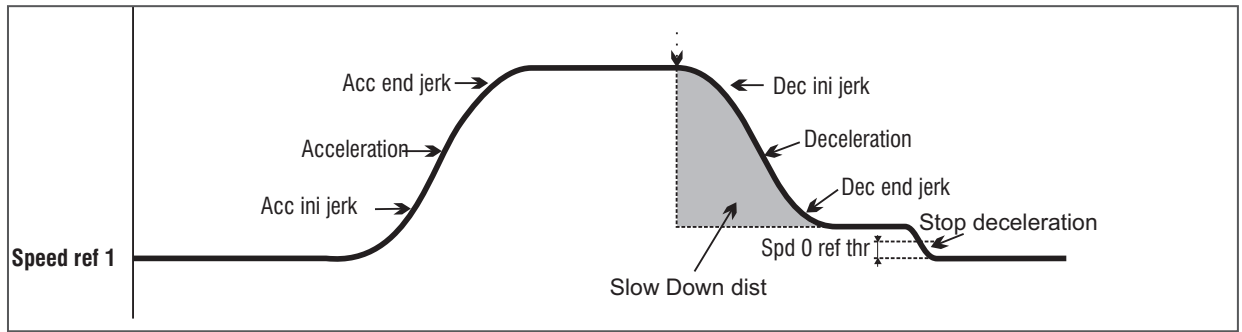

The Acc ini Jerk, Acceleration and Acc end jerk values used to execute the acceleration ramp are calculated by multiplying the corresponding parameters by the acceleration ramp factor (Percent acc factor), while the Dec ini jerk, Deceleration and Dec end jerk values used to execute the deceleration ramp are calculated by multiplying the corresponding parameters by the deceleration ramp factor (**Percent dec factor**, PAR 11056).

When the **Start** command is removed, the reference speed is zero regardless of the reference selected in the multispeeds. In this final part of the profile the jerk deceleration values are used directly (not multiplied by **Percent dec factor**, PAR 11056) with the **Stop deceleration** parameter as the linear deceleration. The factors for the final section of the profile are also used in case of a Stop lift emergency condition.

Menu	PAR	Description	UM	Type	FB BIT	Def	Min	Max	Acc	Mod
5.2.1	11040	Acc ini Jerk	m/s ³	FLOAT		0.50	0.01	20	RW	F__

Setting of the jerk value for the first part of the acceleration.

Menu	PAR	Description	UM	Type	FB BIT	Def	Min	Max	Acc	Mod
5.2.2	11042	Acceleration	m/s ²	FLOAT		0.60	0.01	10	RW	F__

Setting of the maximum acceleration value.

Menu	PAR	Description	UM	Type	FB BIT	Def	Min	Max	Acc	Mod
5.2.3	11044	Acc end jerk	m/s ³	FLOAT		1.40	0.01	20	RW	F__

Setting of the jerk value for the last part of the acceleration.

Menu	PAR	Description	UM	Type	FB BIT	Def	Min	Max	Acc	Mod
5.2.4	11046	Dec ini jerk	m/s ³	FLOAT		1.40	0.01	20	RW	F__

Setting of the jerk value for the first part of the deceleration.

Menu	PAR	Description	UM	Type	FB BIT	Def	Min	Max	Acc	Mod
5.2.5	11048	Deceleration	m/s ²	FLOAT		0.60	0.01	10	RW	F__

Setting of the maximum deceleration value.

Menu	PAR	Description	UM	Type	FB BIT	Def	Min	Max	Acc	Mod
5.2.6	11050	Dec end jerk	m/s ³	FLOAT		0.50	0.01	20	RW	F__

Setting of the jerk value for the last part of the deceleration.

Menu	PAR	Description	UM	Type	FB BIT	Def	Min	Max	Acc	Mod
5.2.7	11052	Stop deceleration	m/s ²	FLOAT		0.70	0.01	10	RW	F__

Setting of the maximum deceleration value used when the start command is removed.

Menu	PAR	Description	UM	Type	FB BIT	Def	Min	Max	Acc	Mod
5.2.8	11054	Percent acc factor	Perc	FLOAT		100.00	10	10000	RW	F__

Setting of the acceleration factor multiplier.

If set to 100 the ramp uses the factors entered in the parameters.

If set to a value of less than 100 the lift will tend to accelerate over a longer distance.
 If set to a value of more than 100 the lift will tend to accelerate over a shorter distance.

Menu	PAR	Description	UM	Type	FB BIT	Def	Min	Max	Acc	Mod
5.2.9	11056	Percent dec factor	Perc	FLOAT		100.00	10	10000	RW	F__

Setting of the deceleration factor multiplier.

If set to 100 the ramp uses the factors entered in the parameters.

If set to a value of less than 100 the lift will tend to decelerate over a longer distance.

If set to a value of more than 100 the lift will tend to decelerate over a shorter distance.

5.3 – LIFT SEQUENCES

This menu shows the parameters used to manage and define the travel of the lift depending on the status of the inputs and alarms. The structure of the lift sequences is summarised below.

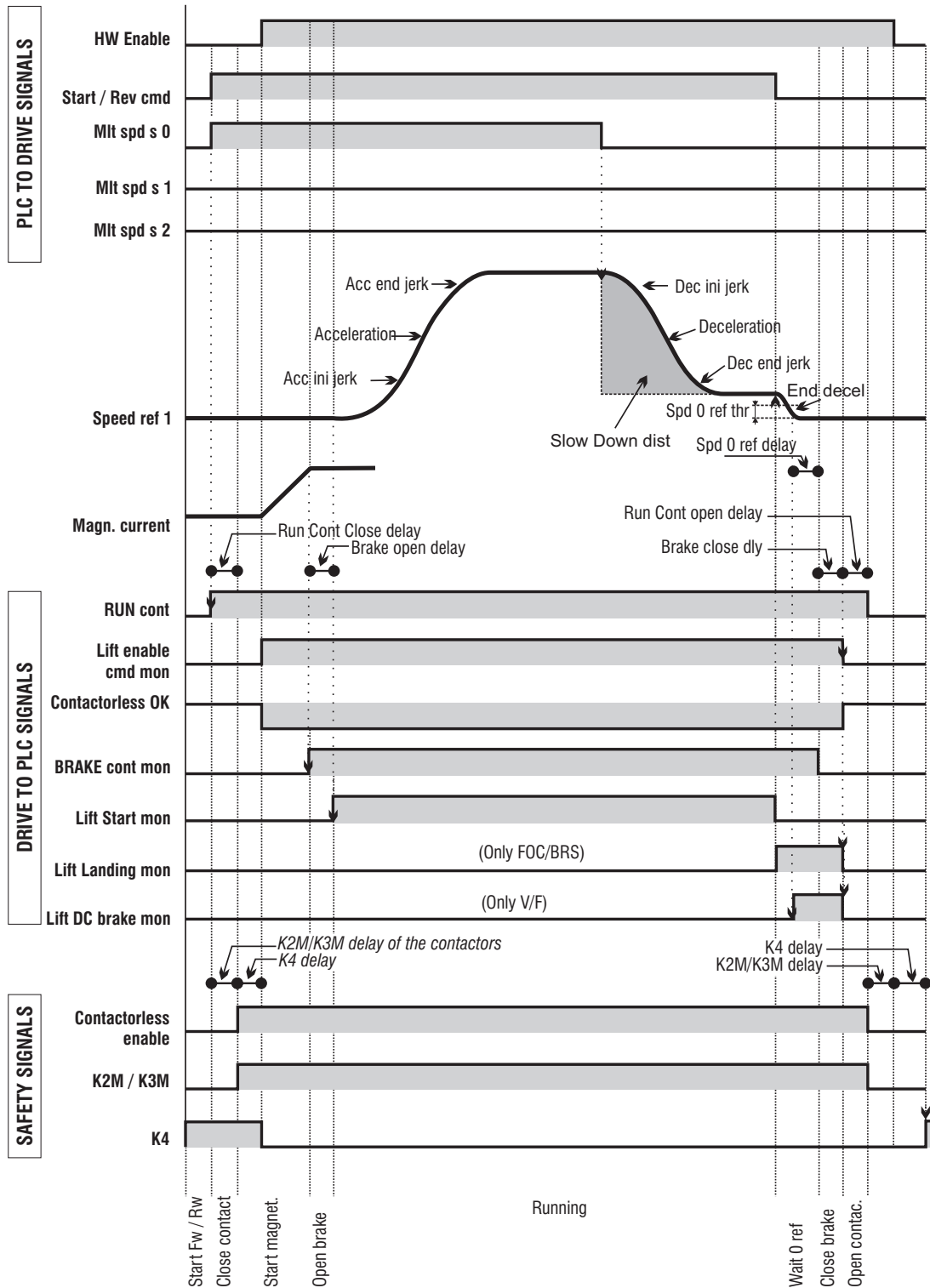

Starting sequence:

- 1 Reading of the enable hardware input and checking for alarms (enabling is aborted in case of an alarm)
- 2 Detection of the **Enable** and **Start** commands as set in the **Sequence start mode** parameter
- 3 When the **Start forward/reverse** command is received, a command is sent to close the contactors, depending on the direction of travel
- 4 When the time set in **Cont close delay** has elapsed the internal **Enable** lift signal is activated
- 5 The system waits for the magnetisation signal from the drive (**Drive ready**)
- 6 At the end of magnetisation the open brake signal is activated

- 7 The system waits for the brake to be opened (**Brake open delay**)
- 8 When the delay before opening the brake has elapsed the **Start** lift command is sent and movement is enabled.

Sequence of movement:

- 1 The motor is started and moves slowly at the speed set in Smooth start speed for the time indicated in **Smooth start delay**
- 2 At the end of **Smooth start delay**, movements are managed by the multispeeds and S-shaped ramp
- 3 When the set speed is exceeded, the **Brake 2 mon** output signal can be used to check that the brake has actually been opened
- 4 The EFC function with space control can be used to change to a slower speed
- 5 When the **Start forward/reverse** signal is lowered the signal indicating arrival at the floor is enabled and the start lift signal is disabled
- 6 The start command can be sent again until the drive reaches zero speed: the operating conditions are restored.

Stopping sequence:

- 1 When zero speed is reached the DC stop command is enabled (**SSC** control)
- 2 The application waits the time needed to reach zero speed and sends the command to close brakes 1 and 2
- 3 It waits the time necessary for the brakes to close (Brake close delay) and, if the current is to be reduced with a ramp, it waits for the current limit to reach zero. The internal Enable lift, arrival zone and DC brake signals are then lowered.
- 4 The application waits the time set in **Contactor open delay** and checks that the current supplied is zero, before sending a command to open the contactors.

It is essential to make sure that whenever a drive alarm condition is generated or the drive is disabled, the drive is stopped and a command is sent to open the contactors.

Menu	PAR	Description	UM	Type	FB BIT	Def	Min	Max	Acc	Mod
5.3.1	11060	Sequence start mode		ENUM		0	0	2	RW	F__

Setting of the procedure to start the contactor command sequence.

- 0 Start forward/reverse
- 1 Enable
- 2 Multispeed != 0

If set to **0** the contactor sequences can be enabled without the Enable command (Enable is only required for motor operation). The Enable signal can be sent by an auxiliary contact of the output contactors.

If set to **1** the contactor sequences can only be enabled if the Enable command is active.

If set to **2** the contactor sequences can be enabled using the multispeed values. Multispeed values other than 0 cause the sequence to start. The start command must also be enabled.

Menu	PAR	Description	UM	Type	FB BIT	Def	Min	Max	Acc	Mod
5.3.2	11062	Cont close delay	ms	INT32		200.00	0	10000	RW	F__

Setting of the delay time for closing the contactor.

Menu	PAR	Description	UM	Type	FB BIT	Def	Min	Max	Acc	Mod
5.3.3	11064	Brake open delay	ms	INT32		200	0	10000	RW	F__

Setting of the brake opening delay time.

Menu	PAR	Description	UM	Type	FB BIT	Def	Min	Max	Acc	Mod
5.3.4	11066	Smooth start delay	ms	INT32		0	0	10000	RW	F__

Setting of the time for which the **Smooth start speed** speed is enabled. If this parameter is set to zero, the S-shaped profile is executed directly at the start, and the soft start function is excluded.

Menu	PAR	Description	UM	Type	FB BIT	Def	Min	Max	Acc	Mod
5.3.5	11068	Brake close delay	ms	INT32		500.00	0	10000	RW	F__

Setting of the brake closing delay time.

Menu	PAR	Description	UM	Type	FB BIT	Def	Min	Max	Acc	Mod
5.3.6	11070	Current down delay	ms	INT32		200	0	10000	RW	F__

Setting of the time necessary to lower the torque from the limit value enabled during travel to 0. It defines the inclination of the down ramp in the "Current down ramp" function. The purpose of this function is to prevent the immediate removal of motor torque when the brake is closed, which would cause mechanical strain in the cabin.

To avoid this phenomenon when the brake is closed the current limits are brought to the current value in use and then lowered on the ramp.

To enable the function the **Current down delay** parameter must be set to a value other than zero.

This is only possible when **Torque curr lim sel** has a value other than "OFF", otherwise **Current down delay** is forced to zero.

Menu	PAR	Description	UM	Type	FB BIT	Def	Min	Max	Acc	Mod
5.3.7	11072	Contactor open delay	ms	INT32		200.00	0	10000	RW	F__

Setting of the contactor opening delay time.

Menu	PAR	Description	UM	Type	FB BIT	Def	Min	Max	Acc	Mod
5.3.8	11078	Speed 0 threshold	rpm	INT16		1.00			RW	F__

Setting of the zero speed threshold, below which the zero speed signal is activated.

Menu	PAR	Description	UM	Type	FB BIT	Def	Min	Max	Acc	Mod
5.3.9	11080	Speed 0 delay	ms	UINT16		400.00	0	10000	RW	F__

Setting of the zero speed delay. After the zero speed signal and after the time set in this parameter the zero speed signal is activated. These parameters are used to know the cabin stop.

Menu	PAR	Description	UM	Type	FB BIT	Def	Min	Max	Acc	Mod
5.3.10	11082	Smooth start speed	Hz	FLOAT		0.00	0.00		RW	F__

Setting of the speed in the smooth start phase.

Menu	PAR	Description	UM	Type	FB BIT	Def	Min	Max	Acc	Mod
5.3.11	11084	Smooth start mode		ENUM		2	1	2	RW	F__

Setting of the soft start mode.

- 1 Speed constant
- 2 Jerk variable

If set to 1 the soft speed is automatically selected after the start command regardless of the selected multispeed. The duration of the smooth speed depends on the **Smooth start delay** parameter: if this parameter is set to zero the selected multispeed is used and not the soft speed. This setting is used in systems with a reducer, as it helps to overcome initial friction before starting with the profile.

If set to 2 an even slower starting mode is set, which uses the start jerk of the variable acceleration in the smooth start phase. Depending on the values set in **Smooth start speed** and **Smooth start delay** the jerk value is calculated at the end of the soft start phase with a linear ramp that changes this jerk from 0 to the calculated value.

The use of a variable value jerk obtains a variable start acceleration that follows a parabolic trajectory, enabling extremely reduced variations in initial speed. This setting is mainly used in systems with gearless motors.

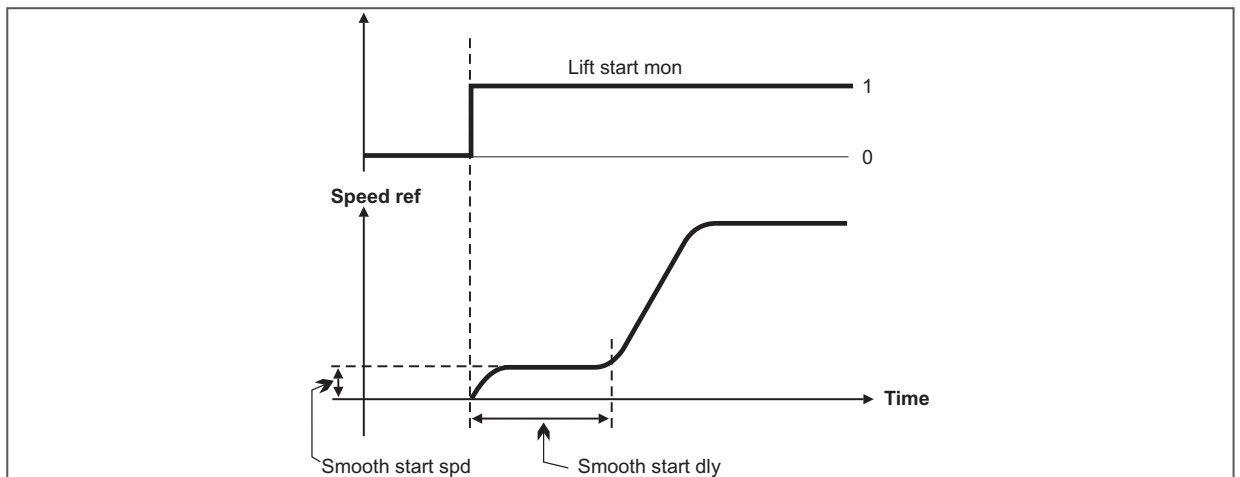

Menu	PAR	Description	UM	Type	FB BIT	Def	Min	Max	Acc	Mod
5.3.12	11086	Door open speed	m/s	FLOAT		0.00			RW	F__

Setting of the door opening speed.

Source to enable brake release through the digital input. In standard sequence brake release is controlled by the drive and therefore this parameter is set to ONE. In case that brake release should be conditioned by some external control (e.g. PLC), set this parameter to digital input controlled by PLC.

Internal sequence for brake release will wait until this input is asserted.

During run brake will be closed whenever this input becomes not asserted.

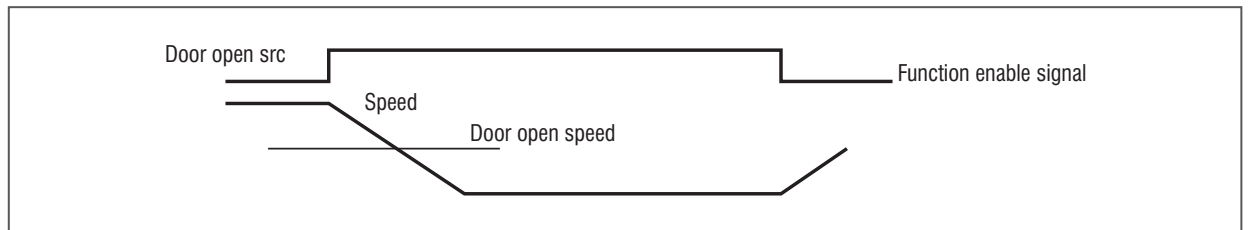

Menu	PAR	Description	UM	Type	FB BIT	Def	Min	Max	Acc	Mod
5.3.13	11088	Contactorless Enable			BIT	0	0	1	RW	FVS

This should be configured if the contactorless mode is desired. By enabling this parameter, the fast enable command is brought to digital Input 7 (if there is no short circuit on the motor phases, this parameter should be returned to the default value) and the drive indicates the contactorless operation mode to the controller through digital output 4 (see Figure 7.3.2.8-A in the ADL300 QS installation manual).

Menu	PAR	Description	UM	Type	FB BIT	Def	Min	Max	Acc	Mod
5.3.14	11822	Em max speed		UINT32		200			R/W	FVS

Sets maximum car (or motor) speed during the maneuver. The speed can be expressed in m/s (for the car) or in rpm (for the motor).

Menu	PAR	Description	UM	Type	FB BIT	Def	Min	Max	Acc	Mod
5.3.15	11824	Brake lock time		UINT32		4	1	30	R/W	FVS

Sets brake lock time when the car reaches maximum allowed speed.

Menu	PAR	Description	UM	Type	FB BIT	Def	Min	Max	Acc	Mod
5.3.16	11826	Inspection Behaviour		Enum		None	0	2	R/Z	FVS

- 0 None
- 1 Fast Stop
- 2 Immediate

Manages the stop ramp in maintenance/inspection mode. If enabled, the function allows greater deceleration compared to nominal deceleration.

Three modes are available:

None: function disabled (default). The car stops with the normal ramps inserted.

Fast Stop: the 200 ms stop function is enabled if the set maintenance speed (PAR 11024 **Multi speed 2** or PAR 11828 **Inspection speed**) is below 0.63 m/s. If the set speed is higher it is automatically limited to 0.63 m/s.

Immediate: car stops immediately with brake close. The car stops immediately (with no ramp) when the button on the maintenance button panel is released.

Menu	PAR	Description	UM	Type	FB BIT	Def	Min	Max	Acc	Mod
5.3.17	11828	Inspection speed		Enum		2			R/Z	FVS

- 0 Multi speed 0
- 1 Multi speed 1
- 2 Multi speed 2
- 3 Multi speed 3
- 4 Multi speed 4
- 5 Multi speed 5
- 6 Multi speed 6
- 7 Multi speed 7
- 8 Null

Maintenance speed.

Menu	PAR	Description	UM	Type	FB BIT	Def	Min	Max	Acc	Mod
5.3.18	12014	Trip number		INT32		0			R	F__

The lift journey counter is displayed. The counter increases each time the Start lift signal is activated.

Menu	PAR	Description	UM	Type	FB BIT	Def	Min	Max	Acc	Mod
5.3.19	12016	Sequence state		UINT16		0			R	F__

The lift sequence status is displayed. (see graph)

5.4 – MECHANICAL DATA

The parameters described in this menu are used to define the mechanical and physical features of the system.

Mechanical constants

The mechanical constant defines the ratio between motor rpm and distance travelled by the cabin.

The **ConstMech** can be calculated in two ways, depending on which conversion method is used.

- **Directly:** **Mechanical constant** = System speed/(Full scale speed/60)

- **Mechanical data:** **Mechanical constant** = $(\pi * \text{Pulley diameter})/\text{Reduction gear ratio}$

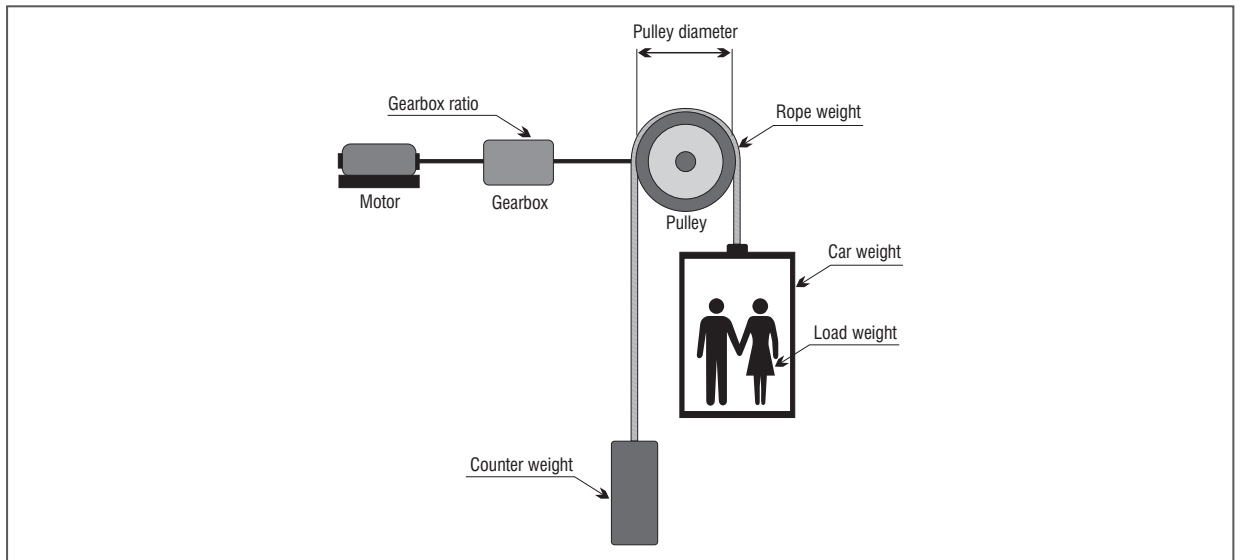

The mechanical constant is calculated when the drive is turned on and re-calculated each time one of the parameters used to determine this value is modified (**Mechanical calc mode**, **Full scale speed**, **Contract speed**, **Pulley diameter**, **Gearbox ratio**).

The method used to calculate the mechanical constant can be selected regardless of the control mode (**SSC**, **Flux vector OL**, **Flux vector CL**, **Synchronous**) or the unit of measure to be used.

Weights and inertia

Entering the mechanical features of the system makes it possible to calculate the total inertia applied to the motor.

After modifying these parameters the calculated inertia value is automatically saved in the “**Inertia comp**” parameter to enable correct inertia compensation.

The value of the inertia that can be entered in the “**Inertia**” parameter in the “16 - SPEED REG GAINS” menu is displayed to calculate the speed loop parameters more accurately. This operation is performed automatically when PAR 11162 Calc spd reg gain is enabled.

Menu	PAR	Description	UM	Type	FB BIT	Def	Min	Max	Acc	Mod
5.4.1	11006	Contract speed	m/s	FLOAT		1	0	10	RW	F__

Represents the speed of the system. It is also used to calculate the mechanical constant. The cabin speed in m/s is associated with the full scale speed (par. 628) to obtain the conversion factor (m/rpm).

Menu	PAR	Description	UM	Type	FB BIT	Def	Min	Max	Acc	Mod
5.4.2	11008	Mechanical calc mode		INT16		0	0	1	ERW	F__

Setting of the method for calculating the unit of measure, depending on the speed of the cabin and of the motor (Direct method) or according to the mechanical ratios (Mechanical data method).

- 0 Direct method
- 1 Mechanical data

Menu	PAR	Description	UM	Type	FB BIT	Def	Min	Max	Acc	Mod
5.4.3	11010	Gearbox ratio		FLOAT		2			ERW	F__

Setting of the ratio between the speed of the motor and of the pulley.

Menu	PAR	Description	UM	Type	FB BIT	Def	Min	Max	Acc	Mod
5.4.4	11012	Pulley diameter	m	FLOAT		0.32			ERW	F__
		Setting of the diameter of the pulley.								
5.4.5	11150	Car weight	kg	FLOAT		0.00			RW	F__
		Setting of the weight of the cabin.								
5.4.6	11152	Counter weight	kg	FLOAT		0.00			RW	F__
		Setting of the weight of the counterweight.								
5.4.7	11154	Load weight	kg	FLOAT		0.00			RW	F__
		Setting of the weight of the maximum load for system dimensions.								
5.4.8	11156	Rope weight	kg	FLOAT		0.00			RW	F__
		Setting of the weight of the cable.								
5.4.9	11158	Gearbox inertia	kgm ²	FLOAT		0.00			RW	F__
		Setting of the inertia of the mechanical reducer.								
5.4.10	11160	Motor inertia	kgm ²	FLOAT		0.00			RW	F__
		Setting of the motor inertia.								
5.4.11	11162	Calc spd reg gains		ENUM	INT	0	0	1	RW	F__
		If enabled this writes the inertia value in parameter 2240 Inertia , calculates the gains of the speed loop, sets parameters 2200 to 2210 to 100% and writes the calculated values in parameters 2236 Speed reg P gain , 2238 Speed reg I time and 2242 Bandwidth . The value of the parameter is automatically reset to 0 once calculation starts.								
5.4.13	12020	Inertia calculated	kgm ²	FLOAT		0			R	F__
		The inertia of the system with half load applied to the motor is displayed. This value can be entered in the Inertia parameter in the "16 - SPEED REG GAINS" menu.								
5.4.13	12022	SpeedLineCalc	m/s	FLOAT		0			R	F__
		The linear speed in m/s calculated using the 11010 Gearboxratio and 11012 Pulleydiam parameters is displayed.								

5.5 – DISTANCE

Use of the distances facilitates positioning of the deceleration sensors and is helpful for managing short floors.

The aim of the function that considers distances is to start decelerating from high speed in order to reach the approach speed in proximity to the landing zone.

Up to a maximum of 8 different slow down distances can be managed (real distance between the start of the sensor and the floor) associated with the different multispeeds. The distance to be used is selected after enabling the drive, before the cabin starts to move. Different distances cannot be selected while the cabin is travelling.

If the slow down distance is shorter than the real deceleration distance for the selected target speed, the speed is automatically limited so that the stop is always correct. When this speed limiter is enabled a **Speed target** alarm (warning) is generated.

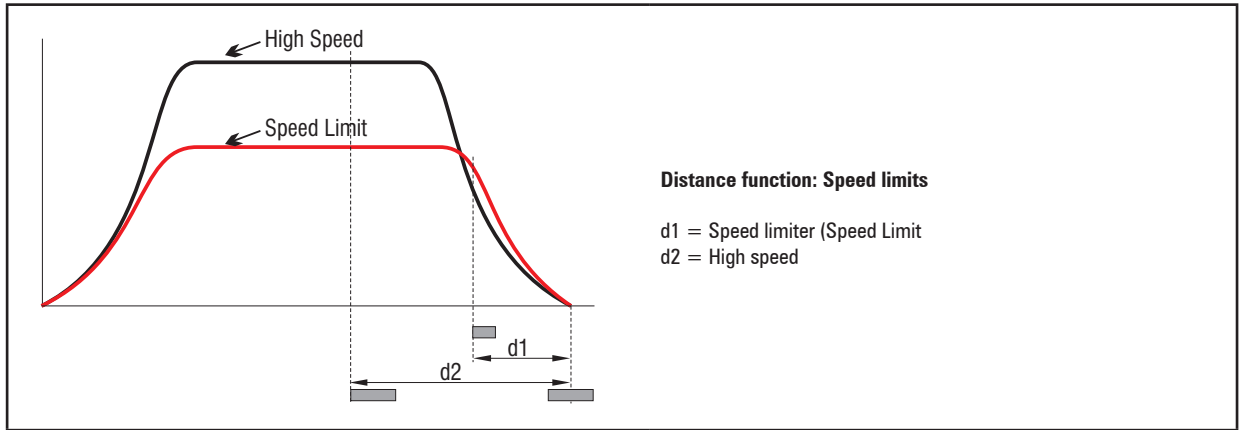

If the slow down sensor is met during acceleration, the distance required to terminate the acceleration and deceleration phases may be greater than the distance available: in that case the last acceleration jerk is increased to enable correct landing.

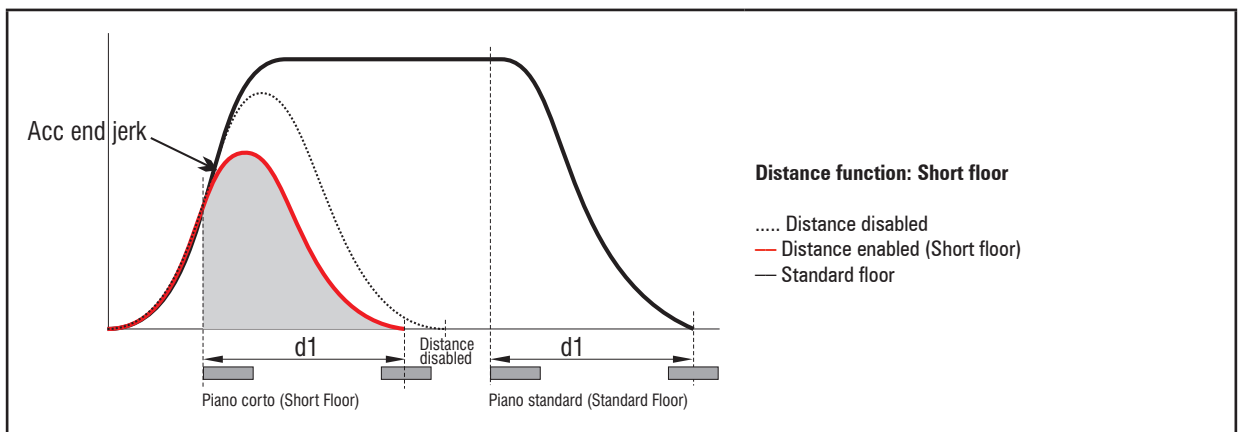

Also note that when the position sensor is not enabled in the landing zone, its exact length is not known. To ensure correct deceleration this distance is estimated on the basis of the value entered in the **Landing zone dist** parameter.

When this is equal to zero the distance is calculated on the basis of the value of the low speed and deceleration parameters and shown in the **Landing zone space** parameter. The user should make sure this distance is approximately the real length of the landing zone.

In FOC mode the distance is calculated by reading the encoder position.

In the SSC and SLS modes the distance is estimated ($\text{SpdRef} \cdot \text{Time}$) and is thus subject to errors due to the difference between the real speed of the motor and the speed reference.

Menu	PAR	Description	UM	Type	FB BIT	Def	Min	Max	Acc	Mod
5.5.1	11102	Distance multispeed0	m	FLOAT		0.00	0.00	10.00	RW	F__

Setting of the value of the distance associated with **multispeed 0**.

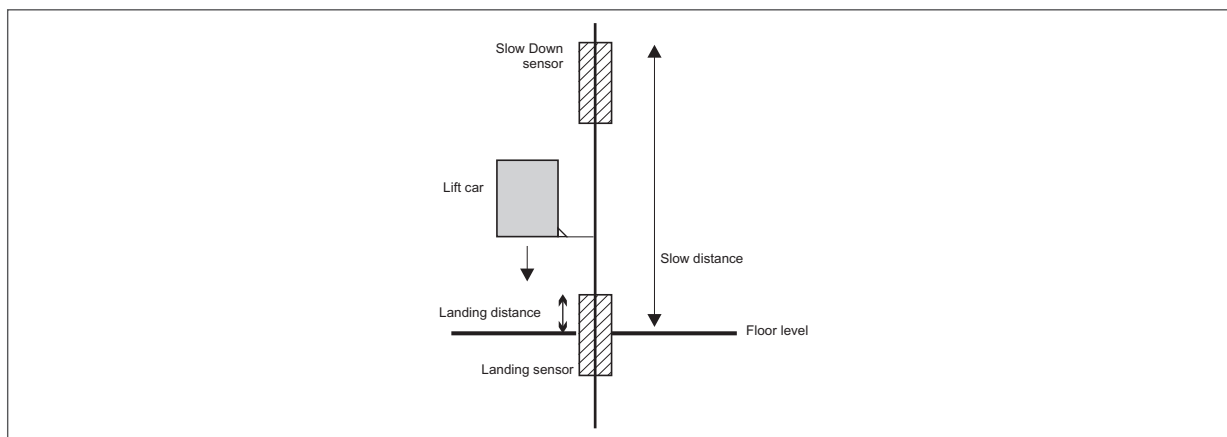

Menu	PAR	Description	UM	Type	FB BIT	Def	Min	Max	Acc	Mod
------	-----	-------------	----	------	--------	-----	-----	-----	-----	-----

5.5.2 11104 Distance multispeed1 m FLOAT 0.00 0.00 10.00 RW F__
 Setting of the value of the distance associated with **multispeed 1**.

Menu	PAR	Description	UM	Type	FB BIT	Def	Min	Max	Acc	Mod
------	-----	-------------	----	------	--------	-----	-----	-----	-----	-----

5.5.3 11106 Distance multispeed2 m FLOAT 0.00 0.00 10.00 RW F__
 Setting of the value of the distance associated with **multispeed 2**.

Menu	PAR	Description	UM	Type	FB BIT	Def	Min	Max	Acc	Mod
------	-----	-------------	----	------	--------	-----	-----	-----	-----	-----

5.5.4 11110 Distance multispeed3 m FLOAT 0.00 0.00 10.00 RW F__
 Setting of the value of the distance associated with **multispeed 3**.

Menu	PAR	Description	UM	Type	FB BIT	Def	Min	Max	Acc	Mod
------	-----	-------------	----	------	--------	-----	-----	-----	-----	-----

5.5.5 11112 Distance multispeed4 m FLOAT 0.00 0.00 10.00 RW F__
 Setting of the value of the distance associated with **multispeed 4**.

Menu	PAR	Description	UM	Type	FB BIT	Def	Min	Max	Acc	Mod
------	-----	-------------	----	------	--------	-----	-----	-----	-----	-----

5.5.6 11114 Distance multispeed5 m FLOAT 0.00 0.00 10.00 RW F__
 Setting of the value of the distance associated with **multispeed 5**.

Menu	PAR	Description	UM	Type	FB BIT	Def	Min	Max	Acc	Mod
------	-----	-------------	----	------	--------	-----	-----	-----	-----	-----

5.5.7 11116 Distance multispeed6 m FLOAT 0.00 0.00 10.00 RW F__
 Setting of the value of the distance associated with **multispeed 6**.

Menu	PAR	Description	UM	Type	FB BIT	Def	Min	Max	Acc	Mod
------	-----	-------------	----	------	--------	-----	-----	-----	-----	-----

5.5.8 11118 Distance multispeed7 m FLOAT 0.00 0.00 10.00 RW F__
 Setting of the value of the distance associated with **multispeed 7**.

Menu	PAR	Description	UM	Type	FB BIT	Def	Min	Max	Acc	Mod
------	-----	-------------	----	------	--------	-----	-----	-----	-----	-----

5.5.9 11120 Slow speed UINT16 0 0 9 RW F__
 Setting of the floor approach speed.

The **Slow speed** is the speed of approach to the landing zone. When the multispeed associated with the **Slow speed** is selected the slow down space is checked in order to reach this speed in proximity to the landing zone.

- 0 Autoselect
- 1 Multispeed 0
- 2 Multispeed 1
- 3 Multispeed 2
- 4 Multispeed 3
- 5 Multispeed 4
- 6 Multispeed 5
- 7 Multispeed 6

- 8 Multispeed 7
- 9 Null

When mode **0 (Autoselect)** is selected, **Slow speed** is automatically connected to the multispeed with absolute value of less and other than zero. If repositioning speeds with a value of less than the **Slow speed** are used, the multispeed corresponding to the floor approach speed must be set.

When mode **9 (Null)** is selected the floor approach spaces are never controlled. In this case the profile depends exclusively on the multispeed selected.

Menu	PAR	Description	UM	Type	FB BIT	Def	Min	Max	Acc	Mod
5.5.10	11130	Enable landing sel		INT16		0	0	1	RW	F__

Setting for enabling space control in the landing zone.

This function enables the cabin to arrive exactly at floor level by controlling the position of the encoder in the landing zone sensor. Position control is only possible if an encoder is used (normally in FOC-BRS). SSC and SLS modes simply generate an appropriate profile on the position reference.

When the function is enabled, the **Slow speed**, PAR 11120 (speed at which the cabin enters the landing zone) no longer depends on the relative multispeed but is calculated automatically according to the jerk and deceleration values to enable stopping without exceeding the set limits.

The value of **Slow speed** (PAR 11120 = 1...8) is calculated using the jerk and deceleration values not multiplied by the ramp factor.

During the landing procedure the speed profile is calculated using the fifth-degree polynomial method.

Direct arrival at floor level is also possible, without using the **Slow speed**. This is done by setting the **Slow speed** multi-speed value to zero.

- 0 Off
- 1 On

Given the solution that has been selected to calculate the speed profile, before enabling the landing zone function it is important to verify the exactness of the spaces that have been entered (for both slow down and landing), and of the mechanical constants. Incorrect spaces could result in sudden decelerations and errors in arrival at floor level.

Menu	PAR	Description	UM	Type	FB BIT	Def	Min	Max	Acc	Mod
5.5.11	11132	Landing zone dist	m	FLOAT		0.12	0	10.00	RW	F__

Setting of the landing zone distance.

Menu	PAR	Description	UM	Type	FB BIT	Def	Min	Max	Acc	Mod
5.5.12	11138	Out floor function		BIT		0	0	1	RW	F__

Enabling of the safe start function when not at floor level. This function enables recognition of arrival at floor level, which is assumed to be correct if the landing zone phase is performed.

If a correct stopping sequence is not recognised this means an emergency stop command has been sent, after which a low speed start is generated.

The restart procedure depends on the stop position as shown in the figure.

- 0 OFF
- 1 ON

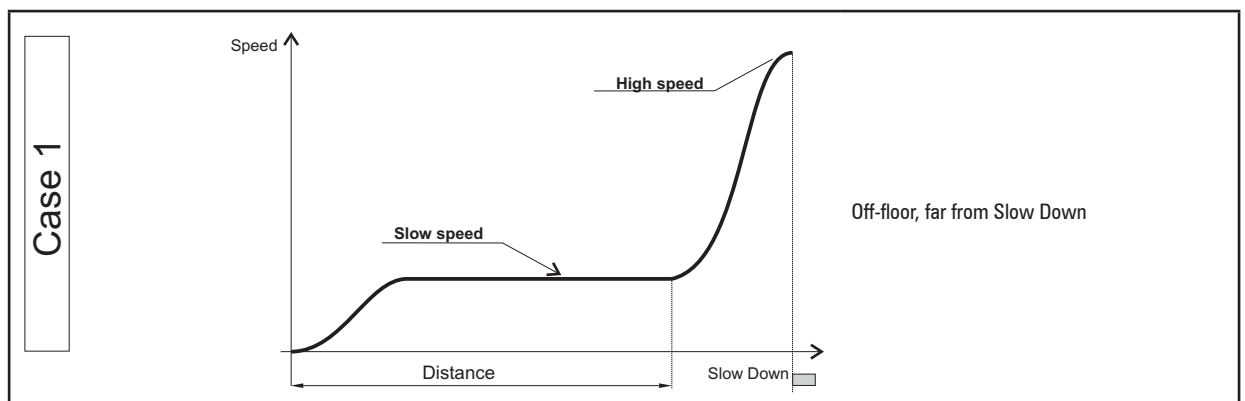

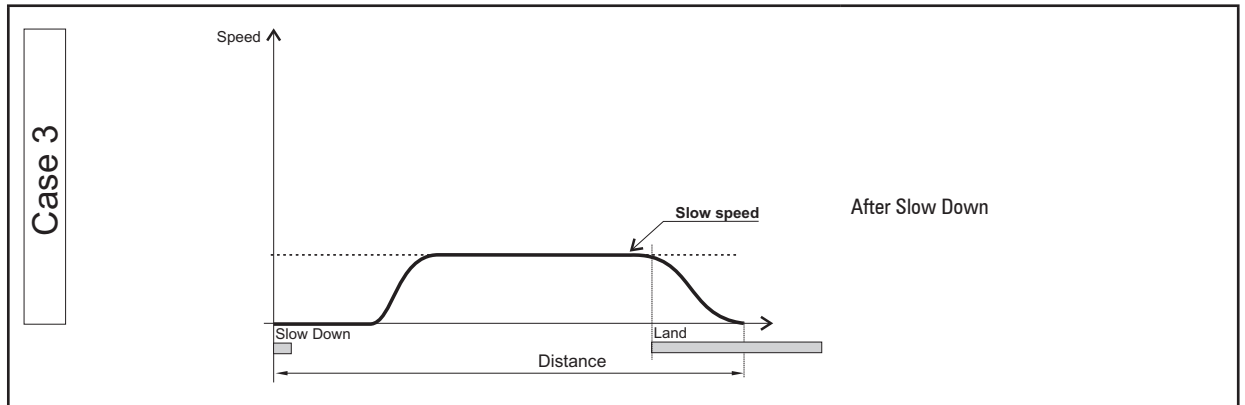
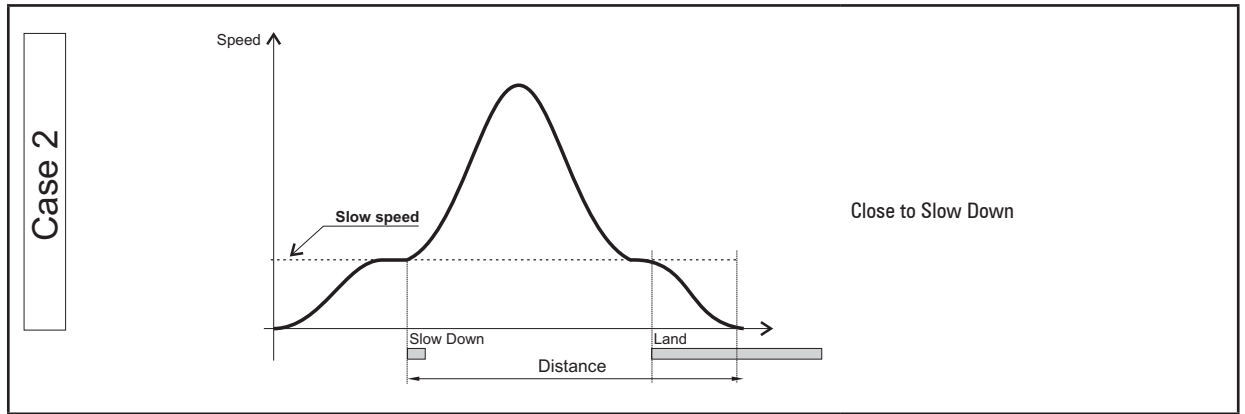

Menu	PAR	Description	UM	Type	FB BIT	Def	Min	Max	Acc	Mod
5.5.13	11140	Delay acq time	m	FLOAT		15	0.00	10.00	RW	F__

Setting of the delay time for sending the slow down signal.

The value of this parameter is used to compensate for the distance covered during the delay time between the passage of the cabin on the slow down sensor and receipt of the decelerate command by the drive. At high speeds this distance can have significant values: e.g. with a cabin travelling at 2 m/s and a delay time of 30 ms, the distance covered and to be taken into consideration during the deceleration phase is 6 cm.

Menu	PAR	Description	UM	Type	FB BIT	Def	Min	Max	Acc	Mod
5.5.14	11142	Calc space hi-speed		UINT16		1	0	8	RW	F__

Setting of the high speed to be used to calculate distances.

- 0 Multispeed 0
- 1 Multispeed 1
- 2 Multispeed 2
- 3 Multispeed 3
- 4 Multispeed 4
- 5 Multispeed 5
- 6 Multispeed 6
- 7 Multispeed 7
- 8 Null

Menu	PAR	Description	UM	Type	FB BIT	Def	Min	Max	Acc	Mod
5.5.15	11276	Kp Landing		Float		0.0000	0	100	RW	FVS

Lets you configure proportional gain to control the landing curve.

Menu	PAR	Description	UM	Type	FB BIT	Def	Min	Max	Acc	Mod
5.5.16	12030	Acceleration space	m	FLOAT		0			R	F__

The distance necessary to accelerate from zero speed to the high speed selected in the previous parameter is displayed.

Menu	PAR	Description	UM	Type	FB BIT	Def	Min	Max	Acc	Mod
5.5.17	12032	Deceleration space	m	FLOAT		0			R	F__

The distance necessary to stop from the high speed is displayed.

Different methods are used to calculate this distance, depending on the value of the relative parameters:

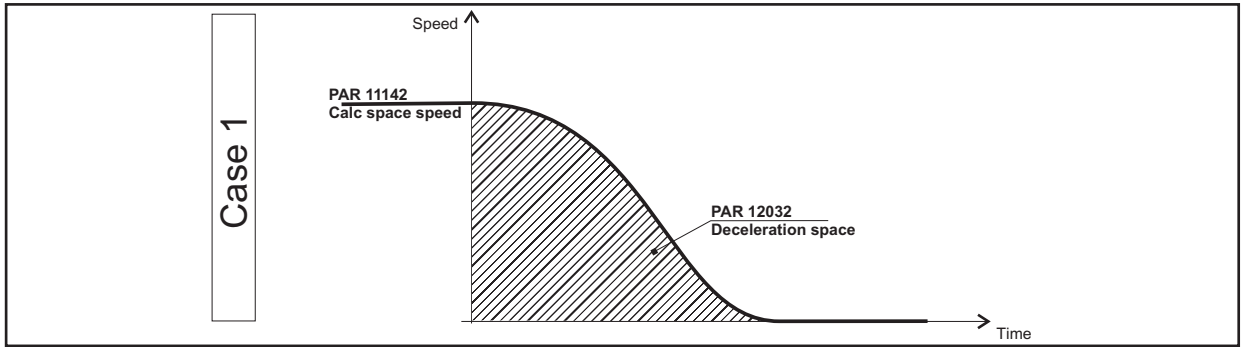

- **Case 1:** -shaped ramp from high speed to zero speed

Distance multispeed0 (PAR 11102) = 0, **Enable landing sel** (PAR 11130) = Disabled, **Slow speed** (PAR 11120) = Zero.

Deceleration space (PAR 12032) the distance covered during the stop ramp from **Calc space hi-speed** (PAR 11142) (high speed) to zero speed.

The parameters that influence the calculation of this distance are: **Calc space hi-speed** (PAR 11142), **Percent dec factor** (PAR 11056), **Dec ini jerk** (PAR 11046), **Deceleration** (PAR 11048) and **Dec end jerk** (PAR 11050).

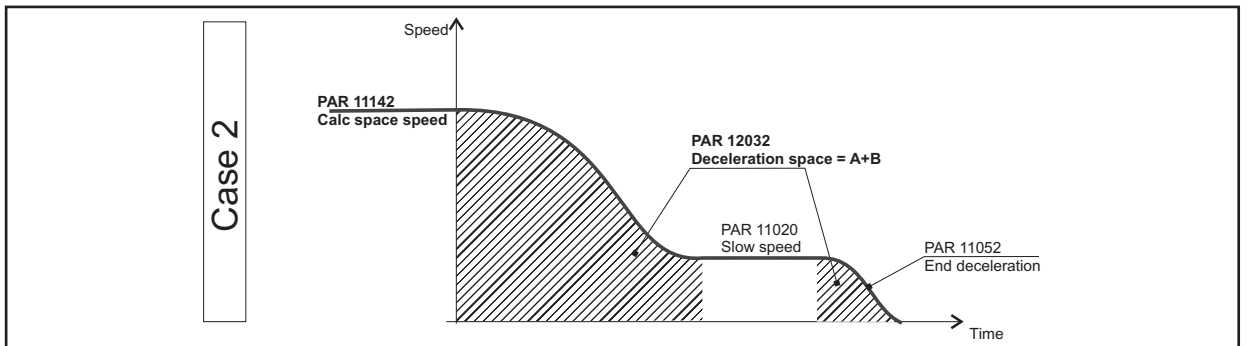

- **Case 2:** S-shaped ramp from high to low speed, low speed zone and subsequent stop

Distance multispeed0 (PAR 11102) = 0, **Enable landing sel** (PAR 11130) = Disabled, **Slow speed** (PAR 11120) = Multispeed 0.

Deceleration space (PAR 12032) is the distance covered during the slow down ramp from **Calc space hi-speed** (PAR 11142) (high speed) to **Multispeed 0** and during the stop ramp from **Calc space hi-speed** (PAR 11142) to zero speed. It does not include the distance covered at constant speed (Low speed).

The parameters that influence the calculation of this distance are: **Calc space hi-speed** (PAR 11142), [11022] **Multispeed 0** (PAR 11020), **Percent dec factor** (PAR 11056), **Dec ini jerk** (PAR 11046), **Deceleration** (PAR 11048), **Dec end jerk** (PAR 11050) and **Stop deceleration** (PAR 11052).

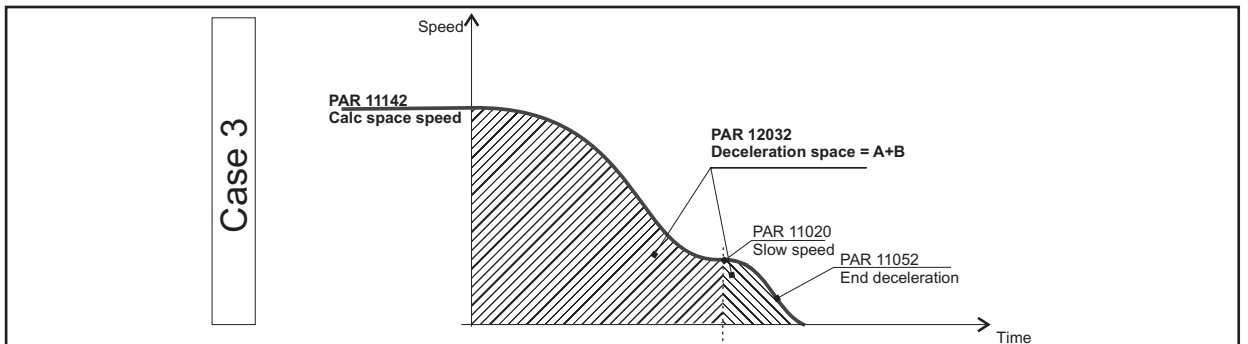

- **Case 3:** S-shaped ramp from high to low speed, low speed zone and subsequent stop

Distance multispeed0 (PAR 11102) $\neq 0$ (es.0.5m), **Enable landing sel** (PAR 11130) = Disabled, **Slow speed** (PAR 11120) = Multispeed 0.

Deceleration space (PAR 12032) is the distance covered during the slow down ramp from **Calc space hi-speed** (PAR 11142) to **Multispeed 0** and during the stop ramp from **Calc space hi-speed** (PAR 11142) to zero speed. It does not include the distance covered at constant speed (Low speed).

The parameters that influence the calculation of this distance are: **Calc space hi-speed** (PAR 11142), [11022] **Multispeed 0** (11020), **Percent dec factor** (PAR 11056), **Dec ini jerk** (PAR 11046), **Deceleration** (PAR 11048) and **Dec end jerk** (PAR 11050).

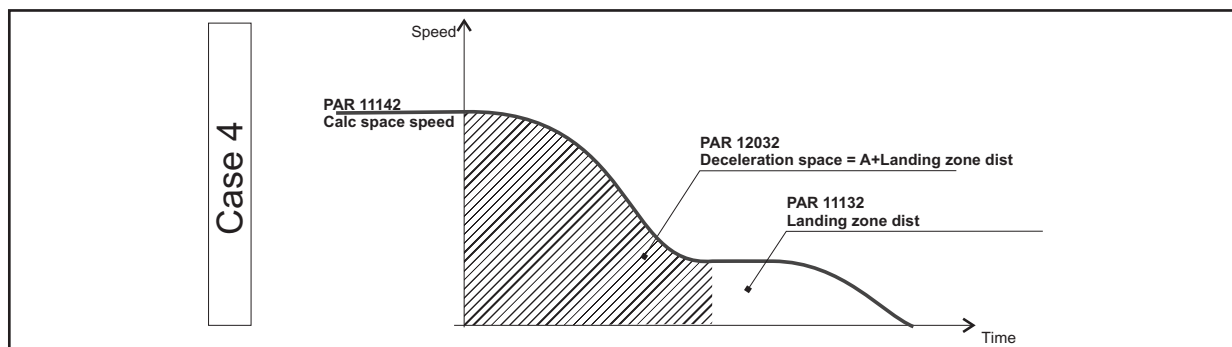

- **Case 4:** S-shaped ramp from high to low speed, low speed zone and subsequent stop with “landing control”

Distance multispeed0 (PAR 11102) $\neq 0$ (es.0.5m), **Enable landing sel** (PAR 11130) = Enabled, **Slow speed** (PAR 11120) = Multispeed 0.

Deceleration space (PAR 12032) is the distance covered during the slow down ramp from **Calc space hi-speed** (PAR 11142) (high speed) to **Multispeed 0** plus **Landing zone dist** (PAR 11132).

The parameters that influence the calculation of this distance are: **Calc space hi-speed** (PAR 11142), [11022] **Multispeed 0** (PAR 11020), **Percent dec factor** (PAR 11056), **Dec ini jerk** (PAR 11046), **Deceleration** (PAR 11048) and **Dec end jerk** (PAR 11050)

Menu	PAR	Description	UM	Type	FB BIT	Def	Min	Max	Acc	Mod
5.5.18	12034	Landing zone space	m	FLOAT		0			R	F__

The landing zone space is displayed. If this parameter is set to a value other than zero, this variable has the same value as the parameter, if **Landing zone space** = 0 this variable assumes the value of the distance necessary to decelerate from the speed set in **Slow speed** to zero using the ramp values not multiplied by the **Percent dec factor**.

5.6 – EMERGENCY MODE

The possibility of operating on an emergency module power supply has been implemented in the drive, to overcome the problem of sudden power failures.

The emergency operation condition signal must be connected to the **Emergency** command input (digital input 3 as default) which, if active, disables the **undervoltage** alarm so that the drive can operate powered on the DC link and EM terminal by the EMS emergency module (which is in turn powered by a buffer battery pack).

In order to use batteries with a lower power rating, a function has been implemented to allow the desired direction of travel to be selected before starting an emergency start procedure.

The direction is selected after testing the movement in both directions, choosing the one that requires less current (for more details see EMS manual).

In case of a blackout the drive can be powered by an Emergency Module Supplier (EMS) or by an Uninterruptible Power Supply (UPS).

The emergency function signal must be connected to the input of the Emergency Mode command (default digital input DI3).

Operation with Emergency Module Supplier (EMS)

If digital input 3 DI3 is active, the Undervoltage (UV) alarm refers to the value set in parameter 448 (menu 4), allowing the drive to run powered on the DC link. See the ADL300 Quick Start manual (paragraph 7.3.3) and the EMS Manual for the connection.

Operation with Single-phase Uninterruptible Power Supply (UPS)

When the emergency is activated by digital input DI3, the Drive can be powered by a 230V single-phase UPS. See the ADL300 Quick Start manual (paragraph 7.3.3) for the connection.

Arrival at floor in Emergency

For both closed-loop and open-loop configurations, arrival at the floor in an emergency is managed by trying to optimize the request for current to the emergency modules.

The drive can select the more favorable direction for arriving at the floor without forward/reverse movements, thereby protecting the parts in emergency.

Menu	PAR	Description	UM	Type	FB BIT	Def	Min	Max	Acc	Mod
5.6.1	11260	Speed emergency mode	m/s	FLOAT		5.00	3.40E+94	3.40E+94	RW	F__
Setting of the speed during movements in the emergency operation condition. Given the low voltage, high speeds cannot be reached with the drive powered by battery (or emergency module). The speed selected in the multispeed parameter is therefore ignored and this value is used instead.										

Menu	PAR	Description	UM	Type	FB BIT	Def	Min	Max	Acc	Mod
5.6.2	11262	Autoselect direction		BIT		0	0	1	ERW	F__
Enabling of automatic selection of preferred direction before an emergency start.										
0 OFF										
1 ON										
2 Recommended										

This parameter lets you select how the drive calculates the more favorable riding direction of the cabin when it is in emergency mode.

If 0 is selected, the drive does not calculate the more favorable direction, which is commanded manually.

If 1 is selected, as soon as the drive is in emergency condition it moves the motor with alternating forward and reverse movements, calculating the value of the current delivered in each direction, and selects the more favorable one (less current requested).

If 2 is selected (recommended mode), the drive evaluates the more favorable direction without making alternating forward and reverse movements (avoiding requests for current from the EMS or UPS), already knowing the more favorable direction because it had already calculated it based on the value of current delivered and on the DC-Link voltage. If the drive was in regeneration before the emergency, it keeps the same riding direction in emergency; if the drive was not in regeneration but was delivering current at a value below the value set in parameter PAR 11284 **Detection Limit**, it keeps the same riding direction. Otherwise, the drive changes riding direction and considers the previous one unfavorable.

Menu	PAR	Description	UM	Type	FB BIT	Def	Min	Max	Acc	Mod
5.6.3	11278	Em Dc brk current		FLOAT		75.0	0	150	RW	FVS
The parameter lets you set the braking current value by injecting DC in the motor windings. You can limit this value and avoid overloading the emergency batteries. Not applicable to Synchronous motors.										

Menu	PAR	Description	UM	Type	FB BIT	Def	Min	Max	Acc	Mod
5.6.4	11284	Detection Limit	PERC	LONG		50	0	100	RW	FVS

This is the current limit value delivered by the drive (expressed as a percentage of nominal current) to select the more favorable riding direction in **Recommended** mode (see PAR 11262).

Menu	PAR	Description	UM	Type	FB BIT	Def	Min	Max	Acc	Mod
5.6.5	12282	ChosenDirection		INT		0	***	***	R	FVS

Indicates the direction selected by the drive during the emergency.

- 0 No direction selected**
- 1 Forward**
- 2 Reverse**

The association Forward/Reverse and Up/Down depends on how the connection to the motor was made.

5.7 – INPUT/OUTPUT

Inputs

The lift application input commands can be connected to a signal via a selector in order to choose from a series of possibilities available in the input list.

Generally speaking a signal can be connected to a digital input, to certain internal signals and to a bit of the Decomp word bit. This word is connected to a fieldbus processing channel (**PDC FieldBus M->S1**).

The set of digital inputs in a word is displayed in the Lift control word.

The commands used in the lift application are listed below:

Command	Description	Default Source
EnableCmd	Enable command	Dig input enable
StartFwdCmd	Start forward command	Dig input 1x
StartRevCmd	Start reverse command	Dig input 2x
MltSpd S0	Multispeed 0 sel	Dig input 4x
MltSpd S1	Multispeed 1 sel	Dig input 5x
MltSpd S2	Multispeed 2 sel	Dig input 6x
ContFbk	Contacteur close contact	Run cont mon
BrakeFbk	Brake close contact	Brake cont mon
DoorOpenEna	Source for enabling the door open function	Null
DoorFbk	Door close contact	Null
Emergency mode	Emergency operation command	Dig input 3x
InvRampSrc	Command to invert the speed direction	Null
UpperLimit	Travel upper limit signal	Null
LowerLimit	Travel lower limit signal	Null

Outputs

The output signals of the lift control are connected directly to the PAD parameters as shown in the table below:

PAR	Signal	Description
3700	Lift enable	LiftEnable
3702	Run cont mon	RunCont
3704	Up cont mon	UpCont
3706	Down cont mon	DownCont
3708	Brake cont mon	BrakeCont
3710	Lift dc brake	LiftDcBrake
3712	Brake 2 mon	Brake2
3714	Door open mon	DoorOpen
3716	Lift start	LiftStart
3718	PAD10	----
3720	Lift status word	Lift status word
3722	PAD12	----
3724	PAD13	----
3726	Ramp down limit	----
3728	PAD15	----
3730	Lift wdec input	LiftWdeclnp

These can be accessed from the selection lists and can thus easily be used to configure the relay and digital outputs of the drive. (refer to the PADS menu for configuration).

The set of lift output signals is contained in the LiftStatusWord, connected to PAR 3720 **Lift status word** and fieldbus Tx DW1:

Bit	Description	Notes
0	LiftEnable	Enable lift command.
1	RunCont	Run command contactor
2	UpCont	Up command contactor
3	DownCont	Down command contactor
4	BrakeCont	Brake command contactor
5	LiftDcBrake	DC brake function command (firmware)
6	Brake2	Brake control signal (see sequences)
7	DoorOpen	Open door command
8	Drive Ok	Drive not in alarm condition signal
9	SpeedIsZero	Speed less than 0 limit signal
10	SpeedRefsZero	Speed reference less than 0 limit signal
11 ... 12		

Multi speed configuration table

Multi speed S2 sel	Multi speed S1 sel	Multi speed S0 sel	ACTIVE RAMP REF
0	0	0	Multi speed 0
0	0	1	Multi speed 1
0	1	0	Multi speed 2
0	1	1	Multi speed 3
1	0	0	Multi speed 4
1	0	1	Multi speed 5
1	1	0	Multi speed 6
1	1	1	Multi speed 7

Menu	PAR	Description	UM	Type	FB BIT	Def	Min	Max	Acc	Mod
5.7.1	11220	Lift enable cmd sel		ENUM		1110	0	35	ERW	F__

Setting of the source for the enable command.

1110	Digit input E
1210	Digit input 1x
1212	Digit input 2x
1214	Digit input 3x
1216	Digit input 4x
1218	Digit input 5x
1220	Digit input 6x
1222	Digit input 7x
1224	Digit input 8x
1226	Digit input 9x
1228	Digit input 10x
1230	Digit input 11x
1232	Digit input 12x
3702	Run cont mon
3706	Down cont mon
3708	Brake cont mon
3714	Door open mon
3728	PAD 15
6000	Null
6002	One
12250	B0 Lift decomp
12252	B1 Lift decomp
12254	B2 Lift decomp
12256	B3 Lift decomp
12258	B4 Lift decomp
12260	B5 Lift decomp
12262	B6 Lift decomp
12264	B7 Lift decomp
12266	B8 Lift decomp
12268	B9 Lift decomp
12270	B10 Lift decomp
12272	B11 Lift decomp
12274	B12 Lift decomp
12276	B13 Lift decomp
12278	B14 Lift decomp
12280	B15 Lift decomp

Menu	PAR	Description	UM	Type	FB BIT	Def	Min	Max	Acc	Mod
5.7.2	11222	Start fwd cmd sel		ENUM		1210	0	35	ERW	F__

Setting of the source for the start forward command.

1110	Digit input E
1210	Digit input 1x
1212	Digit input 2x
1214	Digit input 3x
1216	Digit input 4x
1218	Digit input 5x
1220	Digit input 6x
1222	Digit input 7x
1224	Digit input 8x
1226	Digit input 9x
1228	Digit input 10x
1230	Digit input 11x
1232	Digit input 12x

3702	Run cont mon
3706	Down cont mon
3708	Brake cont mon
3714	Door open mon
3728	PAD 15
6000	Null
6002	One
12250	B0 Lift decomp
12252	B1 Lift decomp
12254	B2 Lift decomp
12256	B3 Lift decomp
12258	B4 Lift decomp
12260	B5 Lift decomp
12262	B6 Lift decomp
12264	B7 Lift decomp
12266	B8 Lift decomp
12268	B9 Lift decomp
12270	B10 Lift decomp
12272	B11 Lift decomp
12274	B12 Lift decomp
12276	B13 Lift decomp
12278	B14 Lift decomp
12280	B15 Lift decomp

Menu	PAR	Description	UM	Type	FB BIT	Def	Min	Max	Acc	Mod
5.7.3	11224	Start rev cmd sel		ENUM		1212	0	35	ERW	F__

Setting of the source for the start reverse command.

1110	Digit input E
1210	Digit input 1x
1212	Digit input 2x
1214	Digit input 3x
1216	Digit input 4x
1218	Digit input 5x
1220	Digit input 6x
1222	Digit input 7x
1224	Digit input 8x
1226	Digit input 9x
1228	Digit input 10x
1230	Digit input 11x
1232	Digit input 12x
3702	Run cont mon
3706	Down cont mon
3708	Brake cont mon
3714	Door open mon
3728	PAD 15
6000	Null
6002	One
12250	B0 Lift decomp
12252	B1 Lift decomp
12254	B2 Lift decomp
12256	B3 Lift decomp
12258	B4 Lift decomp
12260	B5 Lift decomp
12262	B6 Lift decomp
12264	B7 Lift decomp
12266	B8 Lift decomp
12268	B9 Lift decomp
12270	B10 Lift decomp
12272	B11 Lift decomp
12274	B12 Lift decomp
12276	B13 Lift decomp
12278	B14 Lift decomp
12280	B15 Lift decomp

Menu	PAR	Description	UM	Type	FB BIT	Def	Min	Max	Acc	Mod
5.7.4	11226	Multi speed S0 sel		ENUM		1216	0	35	ERW	F__

Setting of the source for the first multispeed selection bit.

1110	Digit input E
1210	Digit input 1x

1212	Digit input 2x
1214	Digit input 3x
1216	Digit input 4x
1218	Digit input 5x
1220	Digit input 6x
1222	Digit input 7x
1224	Digit input 8x
1226	Digit input 9x
1228	Digit input 10x
1230	Digit input 11x
1232	Digit input 12x
3702	Run cont mon
3706	Down cont mon
3708	Brake cont mon
3714	Door open mon
3728	PAD 15
6000	Null
6002	One
12250	B0 Lift decomp
12252	B1 Lift decomp
12254	B2 Lift decomp
12256	B3 Lift decomp
12258	B4 Lift decomp
12260	B5 Lift decomp
12262	B6 Lift decomp
12264	B7 Lift decomp
12266	B8 Lift decomp
12268	B9 Lift decomp
12270	B10 Lift decomp
12272	B11 Lift decomp
12274	B12 Lift decomp
12276	B13 Lift decomp
12278	B14 Lift decomp
12280	B15 Lift decomp

Menu	PAR	Description	UM	Type	FB BIT	Def	Min	Max	Acc	Mod
5.7.5	11228	Multi speed S1 sel		ENUM		1218	0	35	ERW	F__

Setting of the source for the second multispeed selection bit.

1110	Digit input E
1210	Digit input 1x
1212	Digit input 2x
1214	Digit input 3x
1216	Digit input 4x
1218	Digit input 5x
1220	Digit input 6x
1222	Digit input 7x
1224	Digit input 8x
1226	Digit input 9x
1228	Digit input 10x
1230	Digit input 11x
1232	Digit input 12x
3702	Run cont mon
3706	Down cont mon
3708	Brake cont mon
3714	Door open mon
3728	PAD 15
6000	Null
6002	One
12250	B0 Lift decomp
12252	B1 Lift decomp
12254	B2 Lift decomp
12256	B3 Lift decomp
12258	B4 Lift decomp
12260	B5 Lift decomp
12262	B6 Lift decomp
12264	B7 Lift decomp
12266	B8 Lift decomp
12268	B9 Lift decomp
12270	B10 Lift decomp
12272	B11 Lift decomp
12274	B12 Lift decomp

12276 B13 Lift decomp
12278 B14 Lift decomp
12280 B15 Lift decomp

Menu	PAR	Description	UM	Type	FB BIT	Def	Min	Max	Acc	Mod
5.7.6	11230	Multi speed S2 sel		ENUM		1220	0	35	ERW	F__

Setting of the source for the third multispeed selection bit.

1110 Digit input E
1210 Digit input 1x
1212 Digit input 2x
1214 Digit input 3x
1216 Digit input 4x
1218 Digit input 5x
1220 Digit input 6x
1222 Digit input 7x
1224 Digit input 8x
1226 Digit input 9x
1228 Digit input 10x
1230 Digit input 11x
1232 Digit input 12x
3702 Run cont mon
3706 Down cont mon
3708 Brake cont mon
3714 Door open mon
3728 PAD 15
6000 Null
6002 One
12250 B0 Lift decomp
12252 B1 Lift decomp
12254 B2 Lift decomp
12256 B3 Lift decomp
12258 B4 Lift decomp
12260 B5 Lift decomp
12262 B6 Lift decomp
12264 B7 Lift decomp
12266 B8 Lift decomp
12268 B9 Lift decomp
12270 B10 Lift decomp
12272 B11 Lift decomp
12274 B12 Lift decomp
12276 B13 Lift decomp
12278 B14 Lift decomp
12280 B15 Lift decomp

Menu	PAR	Description	UM	Type	FB BIT	Def	Min	Max	Acc	Mod
5.7.7	11232	Contactork fbk sel		ENUM		3702	0	35	ERW	F__

Setting of the source of the contactor status signal.

1110 Digit input E
1210 Digit input 1x
1212 Digit input 2x
1214 Digit input 3x
1216 Digit input 4x
1218 Digit input 5x
1220 Digit input 6x
1222 Digit input 7x
1224 Digit input 8x
1226 Digit input 9x
1228 Digit input 10x
1230 Digit input 11x
1232 Digit input 12x
3702 Run cont mon
3706 Down cont mon
3708 Brake cont mon
3714 Door open mon
3728 PAD 15
6000 Null
6002 One
12250 B0 Lift decomp
12252 B1 Lift decomp
12254 B2 Lift decomp

12256	B3 Lift decomp
12258	B4 Lift decomp
12260	B5 Lift decomp
12262	B6 Lift decomp
12264	B7 Lift decomp
12266	B8 Lift decomp
12268	B9 Lift decomp
12270	B10 Lift decomp
12272	B11 Lift decomp
12274	B12 Lift decomp
12276	B13 Lift decomp
12278	B14 Lift decomp
12280	B15 Lift decomp

Menu	PAR	Description	UM	Type	FB BIT	Def	Min	Max	Acc	Mod
5.7.8	11236	Brake fbk sel		ENUM		3708	0	35	ERW	F__

Setting of the source of the brake status signal.

1110	Digit input E
1210	Digit input 1x
1212	Digit input 2x
1214	Digit input 3x
1216	Digit input 4x
1218	Digit input 5x
1220	Digit input 6x
1222	Digit input 7x
1224	Digit input 8x
1226	Digit input 9x
1228	Digit input 10x
1230	Digit input 11x
1232	Digit input 12x
3702	Run cont mon
3706	Down cont mon
3708	Brake cont mon
3714	Door open mon
3728	PAD 15
6000	Null
6002	One
12250	B0 Lift decomp
12252	B1 Lift decomp
12254	B2 Lift decomp
12256	B3 Lift decomp
12258	B4 Lift decomp
12260	B5 Lift decomp
12262	B6 Lift decomp
12264	B7 Lift decomp
12266	B8 Lift decomp
12268	B9 Lift decomp
12270	B10 Lift decomp
12272	B11 Lift decomp
12274	B12 Lift decomp
12276	B13 Lift decomp
12278	B14 Lift decomp
12280	B15 Lift decomp

Menu	PAR	Description	UM	Type	FB BIT	Def	Min	Max	Acc	Mod
5.7.9	11238	Door open sel		ENUM		6000	0	35	ERW	F__

Setting of the source to enable door closing control.

1110	Digit input E
1210	Digit input 1x
1212	Digit input 2x
1214	Digit input 3x
1216	Digit input 4x
1218	Digit input 5x
1220	Digit input 6x
1222	Digit input 7x
1224	Digit input 8x
1226	Digit input 9x
1228	Digit input 10x
1230	Digit input 11x
1232	Digit input 12x
3702	Run cont mon
3706	Down cont mon
3708	Brake cont mon

3714	Door open mon
3728	PAD 15
6000	Null
6002	One
12250	B0 Lift decomp
12252	B1 Lift decomp
12254	B2 Lift decomp
12256	B3 Lift decomp
12258	B4 Lift decomp
12260	B5 Lift decomp
12262	B6 Lift decomp
12264	B7 Lift decomp
12266	B8 Lift decomp
12268	B9 Lift decomp
12270	B10 Lift decomp
12272	B11 Lift decomp
12274	B12 Lift decomp
12276	B13 Lift decomp
12278	B14 Lift decomp
12280	B15 Lift decomp

Menu	PAR	Description	UM	Type	FB BIT	Def	Min	Max	Acc	Mod
5.7.10	11240	Door feedback sel		ENUM		6000	0	35	ERW	F__

Setting of the source of the door status signal.

1110	Digit input E
1210	Digit input 1x
1212	Digit input 2x
1214	Digit input 3x
1216	Digit input 4x
1218	Digit input 5x
1220	Digit input 6x
1222	Digit input 7x
1224	Digit input 8x
1226	Digit input 9x
1228	Digit input 10x
1230	Digit input 11x
1232	Digit input 12x
3702	Run cont mon
3706	Down cont mon
3708	Brake cont mon
3714	Door open mon
3728	PAD 15
6000	Null
6002	One
12250	B0 Lift decomp
12252	B1 Lift decomp
12254	B2 Lift decomp
12256	B3 Lift decomp
12258	B4 Lift decomp
12260	B5 Lift decomp
12262	B6 Lift decomp
12264	B7 Lift decomp
12266	B8 Lift decomp
12268	B9 Lift decomp
12270	B10 Lift decomp
12272	B11 Lift decomp
12274	B12 Lift decomp
12276	B13 Lift decomp
12278	B14 Lift decomp
12280	B15 Lift decomp

Menu	PAR	Description	UM	Type	FB BIT	Def	Min	Max	Acc	Mod
5.7.11	11242	Emergency mode sel		ENUM		1214	0	35	ERW	F__

Setting of the source of the emergency operation signal.

1110	Digit input E
1210	Digit input 1x
1212	Digit input 2x
1214	Digit input 3x
1216	Digit input 4x
1218	Digit input 5x
1220	Digit input 6x
1222	Digit input 7x
1224	Digit input 8x

1226	Digit input 9x
1228	Digit input 10x
1230	Digit input 11x
1232	Digit input 12x
3702	Run cont mon
3706	Down cont mon
3708	Brake cont mon
3714	Door open mon
3728	PAD 15
6000	Null
6002	One
12250	B0 Lift decomp
12252	B1 Lift decomp
12254	B2 Lift decomp
12256	B3 Lift decomp
12258	B4 Lift decomp
12260	B5 Lift decomp
12262	B6 Lift decomp
12264	B7 Lift decomp
12266	B8 Lift decomp
12268	B9 Lift decomp
12270	B10 Lift decomp
12272	B11 Lift decomp
12274	B12 Lift decomp
12276	B13 Lift decomp
12278	B14 Lift decomp
12280	B15 Lift decomp

Menu	PAR	Description	UM	Type	FB BIT	Def	Min	Max	Acc	Mod
5.7.12	11244	Inversion ramp sel		ENUM		6000	0	35	ERW	F__

Setting of the source of the command that inverts the direction of the output speed.

1110	Digit input E
1210	Digit input 1x
1212	Digit input 2x
1214	Digit input 3x
1216	Digit input 4x
1218	Digit input 5x
1220	Digit input 6x
1222	Digit input 7x
1224	Digit input 8x
1226	Digit input 9x
1228	Digit input 10x
1230	Digit input 11x
1232	Digit input 12x
3702	Run cont mon
3706	Down cont mon
3708	Brake cont mon
3714	Door open mon
3728	PAD 15
6000	Null
6002	One
12250	B0 Lift decomp
12252	B1 Lift decomp
12254	B2 Lift decomp
12256	B3 Lift decomp
12258	B4 Lift decomp
12260	B5 Lift decomp
12262	B6 Lift decomp
12264	B7 Lift decomp
12266	B8 Lift decomp
12268	B9 Lift decomp
12270	B10 Lift decomp
12272	B11 Lift decomp
12274	B12 Lift decomp
12276	B13 Lift decomp
12278	B14 Lift decomp
12280	B15 Lift decomp

Menu	PAR	Description	UM	Type	FB BIT	Def	Min	Max	Acc	Mod
5.7.13	11246	Upper limit sel		ENUM		6000	0	35	ERW	F__

Setting of the source of the upper limit enabling signal.

1110	Digit input E
1210	Digit input 1x
1212	Digit input 2x

1214	Digit input 3x
1216	Digit input 4x
1218	Digit input 5x
1220	Digit input 6x
1222	Digit input 7x
1224	Digit input 8x
1226	Digit input 9x
1228	Digit input 10x
1230	Digit input 11x
1232	Digit input 12x
3702	Run cont mon
3706	Down cont mon
3708	Brake cont mon
3714	Door open mon
3728	PAD 15
6000	Null
6002	One
12250	B0 Lift decomp
12252	B1 Lift decomp
12254	B2 Lift decomp
12256	B3 Lift decomp
12258	B4 Lift decomp
12260	B5 Lift decomp
12262	B6 Lift decomp
12264	B7 Lift decomp
12266	B8 Lift decomp
12268	B9 Lift decomp
12270	B10 Lift decomp
12272	B11 Lift decomp
12274	B12 Lift decomp
12276	B13 Lift decomp
12278	B14 Lift decomp
12280	B15 Lift decomp

Menu	PAR	Description	UM	Type	FB BIT	Def	Min	Max	Acc	Mod
5.7.14	11248	Lower limit sel		ENUM		6000	0	35	ERW	F__

Setting of the source of the lower limit enabling signal.

1110	Digit input E
1210	Digit input 1x
1212	Digit input 2x
1214	Digit input 3x
1216	Digit input 4x
1218	Digit input 5x
1220	Digit input 6x
1222	Digit input 7x
1224	Digit input 8x
1226	Digit input 9x
1228	Digit input 10x
1230	Digit input 11x
1232	Digit input 12x
3702	Run cont mon
3706	Down cont mon
3708	Brake cont mon
3714	Door open mon
3728	PAD 15
6000	Null
6002	One
12250	B0 Lift decomp
12252	B1 Lift decomp
12254	B2 Lift decomp
12256	B3 Lift decomp
12258	B4 Lift decomp
12260	B5 Lift decomp
12262	B6 Lift decomp
12264	B7 Lift decomp
12266	B8 Lift decomp
12268	B9 Lift decomp
12270	B10 Lift decomp
12272	B11 Lift decomp
12274	B12 Lift decomp
12276	B13 Lift decomp
12278	B14 Lift decomp
12280	B15 Lift decomp

Menu	PAR	Description	UM	Type	FB BIT	Def	Min	Max	Acc	Mod
5.7.15	11250	Dcp3 mode command		BIT		0	0	1	ERW	F__

Enabling of reading of commands from DCP3 serial protocol

- 0 OFF
- 1 ON

Menu	PAR	Description	UM	Type	FB BIT	Def	Min	Max	Acc	Mod
5.7.16	11252	Brake fbk A3 sel		ENUM		0	0	1	RW	FVS

Selection of the brake fault alarm In the default configuration the brake fault alarm function is disabled.

Setting of the source to enable:

- 6000 Null
- 6002 One
- 12250 B0 Lift decomp
- 12252 B1 Lift decomp
- 12254 B2 Lift decomp
- 12256 B3 Lift decomp
- 12258 B4 Lift decomp
- 12260 B5 Lift decomp
- 12262 B6 Lift decomp
- 12264 B7 Lift decomp
- 12266 B8 Lift decomp
- 12268 B9 Lift decomp
- 12270 B10 Lift decomp
- 12272 B11 Lift decomp
- 12274 B12 Lift decomp
- 12276 B13 Lift decomp
- 12278 B14 Lift decomp
- 12280 B15 Lift decomp
- 13000 F0 Rising
- 13001 F0 Falling
- 13002 F1 Rising
- 13003 F1 Falling
- 1110 Digit input E
- 1210 Digit input 1x
- 1212 Digit input 2x
- 1214 Digit input 3x
- 1216 Digit input 4x
- 1218 Digit input 5x
- 1220 Digit input 6x
- 1222 Digit input 7x
- 1224 Digit input 8x
- 1226 Digit input 9x
- 1228 Digit input 10x
- 1230 Digit input 11x
- 1232 Digit input 12x
- 3702 Run cont mon
- 3706 Down cont mon
- 3708 Brake cont mon
- 3714 Door open mon

Menu	PAR	Description	UM	Type	FB BIT	Def	Min	Max	Acc	Mod
5.7.17	11256	SpeedRefSrc		ENUM		0	0	1	RW	FVS

Selection of the origin (source) of the signal to be used for the speed reference. The signals that can be used are multi-speed, analog inputs or fieldbus (except the PAR **4020 Fieldbus M->S1 ipa**)

Menu	PAR	Description	UM	Type	FB BIT	Def	Min	Max	Acc	Mod
5.7.18	11258	Lift EF alarm sel		ENUM		0	0	1	RW	FVS

Selection of the origin (source) of "Lift external fault".

Menu	PAR	Description	UM	Type	FB BIT	Def	Min	Max	Acc	Mod
5.7.19	11272	Fast Enable sel		ENUM		1	0	1	RW	FVS

This parameter enables the Fast Enable command to digital Input 8. Entry to Digital Input 8 must be controlled by the controller. The enable should be completed with contactorless operation. This parameter is an additional Enable used to quickly disable the drive in case of emergencies or use of the motor phases short circuit configured without contactors.

Menu	PAR	Description	UM	Type	FB BIT	Def	Min	Max	Acc	Mod
5.7.20	11274	Landing cmd src		ENUM		NULL	***	***	RW	FVS

You can enable the Landing command with the Start signal as well as from Digital Inputs and Freeze inputs. If you select

Freeze inputs, the command is activated on the encoder inputs (see the ADL300 Quick Start manual to identify the encode Freeze inputs).

Rising (rising/positive edge) means active on the rising edge of the signal; Falling (falling/negative edge) active on the falling edge.

6000	Null
6002	One
12250	B0 Lift decomp
12252	B1 Lift decomp
12254	B2 Lift decomp
12256	B3 Lift decomp
12258	B4 Lift decomp
12260	B5 Lift decomp
12262	B6 Lift decomp
12264	B7 Lift decomp
12266	B8 Lift decomp
12268	B9 Lift decomp
12270	B10 Lift decomp
12272	B11 Lift decomp
12274	B12 Lift decomp
12276	B13 Lift decomp
12278	B14 Lift decomp
12280	B15 Lift decomp
13000	F0 Rising
13001	F0 Falling
13002	F1 Rising
13003	F1 Falling
1110	Digit input E
1210	Digit input 1x
1212	Digit input 2x
1214	Digit input 3x
1216	Digit input 4x
1218	Digit input 5x
1220	Digit input 6x
1222	Digit input 7x
1224	Digit input 8x
1226	Digit input 9x
1228	Digit input 10x
1230	Digit input 11x
1232	Digit input 12x
3702	Run cont mon
3706	Down cont mon
3708	Brake cont mon
3714	Door open mon

Menu	PAR	Description	UM	Type	FB BIT	Def	Min	Max	Acc	Mod
5.7.21	11820	Brake Release Sel		ENUM		Null			R/W	FVS

The assignable functions are on the “L_DIGSEL1” selection list.

Manual emergency maneuver. This function allows the car to move when there is a power failure in order to bring it to the closest floor by gravity.

- This maneuver can be performed only when the drive is in emergency mode, which the control card indicates with the “Emergency Mode” digital input. There must be a Brake Open digital input connected to a Brake Open button on the control panel that enables car movement.
- When the button is pushed the inverter opens the brake contactor via the Brake Contactor Relay output.
- The operator has to push the “Brake Open” button to move the car.
- PAR 11822 **Em max speed** sets the maximum speed that the car (or the motor) can have during this maneuver.
- If the car reaches the maximum allowed speed, the drive locks the brake for a time T set by parameter 11824 **Brake lock time**, disabling use of the button (which will not release the brake even if pushed).
- When activating this maneuver, the display (both optional and built-in) shows the current car speed (or motor speed if set in rpm) and direction (Fwd or rev).
- This maneuver is disabled in case of inspection.

Menu	PAR	Description	UM	Type	FB BIT	Def	Min	Max	Acc	Mod
5.7.22	12102	Command input mon		UINT32		0			ER	FVS

The hexadecimal value of the input status is displayed, refer to the “lift control word” for a description of the meaning of each bit.

Menu	PAR	Description	UM	Type	FB BIT	Def	Min	Max	Acc	Mod
5.7.23	12104	Command output mon		UINT32		0			ER	FVS

The hexadecimal value of the input status is displayed, refer to the “lift status word” for a description of the meaning of each bit.

5.8 –PRE - TORQUE

The Pre-torque function helps to guarantee a linear start without any initial acceleration. This is possible by setting a torque value that corresponds to the load before opening the brake. The value of the initial torque applied to the motor and the direction of the torque applied can be supplied by installing a load cell on the lift cabin. The load cell signal is acquired via the analog input and appropriately scaled if using the Pre-torque function.

If a load cell is not installed, a fixed torque value can be used, only supplying the direction of torque. In that case the fixed torque value is only optimised for one load condition.

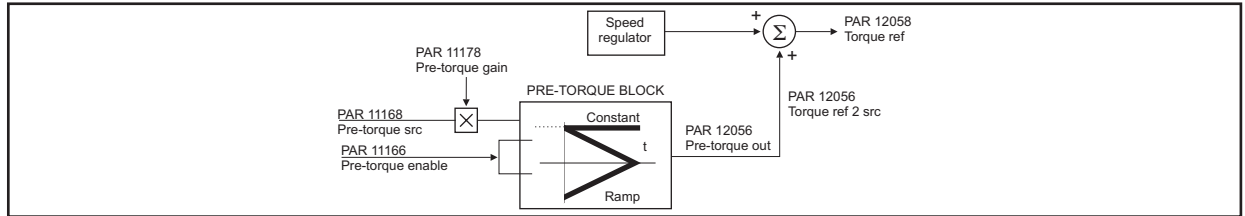

Menu	PAR	Description	UM	Type	FB BIT	Def	Min	Max	Acc	Mod	
5.8.1	11166	Pre-torque enable		BIT		0	0	1	RW	F	
		Enabling of the pre-torque function									
		0	OFF								
		1	ON								

Menu	PAR	Description	UM	Type	FB BIT	Def	Min	Max	Acc	Mod
5.8.2	11168	Pre-torque source		INT16		11170	0	2	RW	F
		Selection of the origin (source) of the signal used for the pre-torque function.								
	1600	Analog inp 1								
	1650	Analog inp 2								
	4034	FieldbusM->S2								
	4044	FieldbusM->S3								
	4054	FieldbusM->S4								
	4064	FieldbusM->S5								
	4074	FieldbusM->S6								
	4084	FieldbusM->S7								
	4094	FieldbusM->S8								
	4104	FieldbusM->S9								
	4114	FieldbusM->S10								
	4124	FieldbusM->S11								
	4134	FieldbusM->S12								
	4144	FieldbusM->S13								
	4154	FieldbusM->S14								
	4164	FieldbusM->S15								
	4174	FieldbusM->S16								
	11170	Int pretorque								

Menu	PAR	Description	UM	Type	FB BIT	Def	Min	Max	Acc	Mod
5.8.3	11170	Init pre-torque		INT32		1000			RW	F
		Setting of the reference value used in the pre-torque function only if the Pre-torque source parameter is set to 0. The value set in this parameter only enables the pre-torque function to be optimised for one load condition. The pre-torque function can also be optimised for different load conditions by using the fieldbus to modify the setting of this parameter.								

Menu	PAR	Description	UM	Type	FB BIT	Def	Min	Max	Acc	Mod
5.8.4	11172	Pre-torque ramp up	ms	INT32		0	0	10000	RW	F
		Setting of the ramp time for the rising edge of the torque value (before opening the brake): if this parameter is set to zero the constant feed-forward torque value is maintained during travel.								

Menu	PAR	Description	UM	Type	FB BIT	Def	Min	Max	Acc	Mod
5.8.5	11174	Pre-torque ramp down	ms	INT32		0	0	60000	RW	F
		Setting of the ramp time for the falling edge of the torque value: if this parameter is set to zero the constant feed-forward torque value is maintained during travel.								

Menu	PAR	Description	UM	Type	FB BIT	Def	Min	Max	Acc	Mod
5.8.6	11176	Pre-torque offset		FLOAT		0			RW	F
Setting of the offset value applied to the input reference of the pre-torque function.										

Menu	PAR	Description	UM	Type	FB BIT	Def	Min	Max	Acc	Mod
5.8.7	11178	Pre torque gain		FLOAT		1			RW	F
Setting of the gain value used to convert the value applied to the analog input in the torque value to be used in the function. This gain is calculated automatically according to the weights and inertia values entered. Ideally, the reference must be set so that the minimum value corresponds to the empty cabin and the maximum value to the full load.										

Menu	PAR	Description	UM	Type	FB BIT	Def	Min	Max	Acc	Mod
5.8.8	12040	Pre-torque input	cnt	INT32		0			ER	F
The reference value sampled at start is displayed.										

Menu	PAR	Description	UM	Type	FB BIT	Def	Min	Max	Acc	Mod
5.8.9	12056	Pre-torque out	cnt	INT32		0			ER	F
The feed forward torque value output of the pre-torque function is displayed.										

Menu	PAR	Description	UM	Type	FB BIT	Def	Min	Max	Acc	Mod
5.8.10	12058	Torque reference	cnt	INT32		0			ER	F
The torque reference value is displayed, given by the sum of the speed loop output and the torque feed forward.										

5.9 – LIFT ALARMS

The MdPlc application for ADL300 manages and generates the following alarms:

Alarm	Alarm type	Description
Plc1 fault	Cont feedback	Contactorm feedback signal error
Plc2 fault	Brake feedback	Brake feedback signal error
Plc3 fault	Door feedback	Door feedback signal error
Plc6 fault	Speed limited	Warning of speed limit to guarantee stop
Plc7 fault	Up/low limit	Speed limit exceeded in power factor regulation zone

All alarms are associated with a parameter to configure the action taken when the alarm is activated.

Activity: used to set the action to be performed after activation of the alarm, as follows.

Action

Ignore	The alarm is not included in the alarm list, it is not included in the alarm log, it is not signalled on the digital outputs, commands to the drive are not modified.
Warning	The alarm is included in the alarm list, it is included in the alarm log, it is signalled on the digital outputs, First alarm information is updated, Enabled alarms information is updated, commands to the drive are not modified.
Disable	The alarm is included in the alarm list, it is included in the alarm log, it is signalled on the digital outputs, First alarm information is updated, Enabled alarms information is updated, a stop command is sent, the motor is disabled and stops due to inertia.
Fast Stop	The alarm is included in the alarm list, it is included in the alarm log, it is signalled on the digital outputs, First alarm information is updated, Enabled alarms information is updated, a Stop command is sent. The drive is set to zero speed with the maximum available current; when the Speed 0 delay signal is activated the drive is disabled.
Lift Fast stop	When there is an alarm occurrence, lift will be stopped (ramp reference is set to zero) immediately with fast ramp, after that it will remain in alarm state. Attention: this will cause the cabin to stop out of floor !
Lift stop	When there is an alarm occurrence, lift will continue to run until next stop condition, after that it will remain in alarm state.

Menu	PAR	Description	UM	Type	FB BIT	Def	Min	Max	Acc	Mod
5.9.1	11058	Lift fast stop fact		FLOAT		10.00	1.00	50.00	RW	FVS
<p>This parameter is applied to all ramps when a "Quick stop" alarm occurs. The default setting is 10 = 1000% (standard ramps multiplied by 10). To use standard ramps with no multiplication, set 1 = 100%.</p>										

Menu	PAR	Description	UM	Type	FB BIT	Def	Min	Max	Acc	Mod
5.9.2	11200	Contactorm activity		INT16		1	0	5	RW	FVS
<p>Setting of drive behaviour in case of a Cont fbk fail alarm. This alarm indicates that the feedback confirming closing of the contactorm has not been received.</p> <p>0 Ignore 1 Warning 2 Disable 3 Fast Stop 4 Lift Fast stop 5 Lift stop</p>										

Menu	PAR	Description	UM	Type	FB BIT	Def	Min	Max	Acc	Mod
5.9.3	11202	Cont hold off	ms	INT32		3000			RW	FVS
<p>Setting of the delay time between activation of the Cont fbk fail alarm condition signal and the actual alarm. In case of an alarm condition, the drive waits for the set time to elapse before activating the alarm. If the alarm is removed within the set time, the drive will not activate the alarm.</p>										

Menu	PAR	Description	UM	Type	FB BIT	Def	Min	Max	Acc	Mod
5.9.4	11204	Brake activity		INT16		1	0	5	RW	FVS
<p>Setting of drive behaviour in case of a Brake fbk fail alarm. This alarm indicates that the feedback confirming opening/closing of the brake has not been received.</p>										

- 0 Ignore
- 1 Warning
- 2 Disable
- 3 Fast Stop
- 4 Lift Fast stop
- 5 Lift stop

Menu	PAR	Description	UM	Type	FB BIT	Def	Min	Max	Acc	Mod
5.9.5	11206	Brake hold off	ms	INT32		3000.00			RW	FVS

Setting of the delay time between activation of the Brake fbk fail alarm condition signal and the actual alarm. In case of an alarm condition, the drive waits for the set time to elapse before activating the alarm. If the alarm is removed within the set time, the drive will not activate the alarm.

Menu	PAR	Description	UM	Type	FB BIT	Def	Min	Max	Acc	Mod
5.9.6	11208	Brake run hold off		INT16		1	0	1	RW	FVS

Setting of drive behaviour when a possible Brake fbk fail alarm is detected.

- 0 Disable
- 1 Enable

If set to 0 the brake feedback alarm is indicated immediately

If set to 1 the possible brake feedback alarm is indicated at the end of travel: this allows the cabin to reach the floor in case of a faulty brake status signal.

Menu	PAR	Description	UM	Type	FB BIT	Def	Min	Max	Acc	Mod
5.9.7	11210	Door activity		INT16		1	0	5	RW	FVS

Setting of drive behaviour in case of a **Door fbk fail** alarm. This alarm indicates that the feedback confirming opening of the door has not been received.

- 0 Ignore
- 1 Warning
- 2 Disable
- 3 Fast Stop
- 4 Lift Fast stop
- 5 Lift stop

Menu	PAR	Description	UM	Type	FB BIT	Def	Min	Max	Acc	Mod
5.9.8	11212	Door hold off	ms	INT32		1000			RW	FVS

Setting of the delay time between activation of the **Door fbk fail** alarm condition signal and the actual alarm. In case of an alarm condition, the drive waits for the set time to elapse before activating the alarm. If the alarm is removed within the set time, the drive will not activate the alarm.

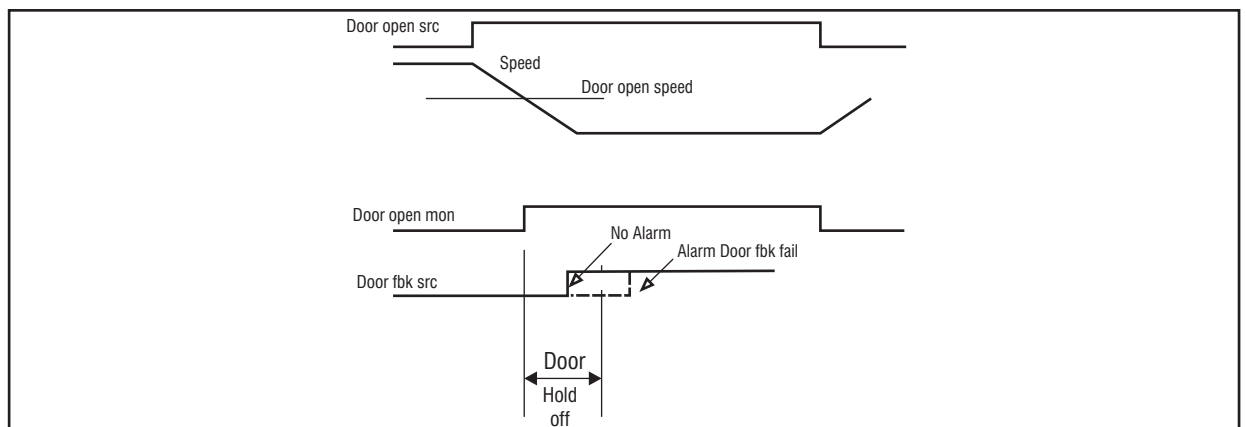

Menu	PAR	Description	UM	Type	FB BIT	Def	Min	Max	Acc	Mod
5.9.9	11214	Limit activity		INT16		5	0	5	RW	FVS

Setting of drive behaviour in case of the **Upper/Lower limit**. This alarm occurs when the speed is greater than PAR 11216 **Limit speed thr** and are active sensors installed at the beginning and end of the space. This function implemented in the drive provides an additional control to avoid overtravel.

The alarm condition is generated, when the set speed limit is exceeded.

The UpperLimit or LowerLimit inputs must be set to enable speed limit control. The **UpperLimit** must always correspond to the upper limit signal and the **LowerLimit** must always correspond to the lower limit signal.

- 0 Ignore
- 1 Warning
- 2 Disable
- 3 Fast Stop
- 4 Lift Fast stop
- 5 Lift stop

Menu	PAR	Description	UM	Type	FB BIT	Def	Min	Max	Acc	Mod
5.9.10	11216	Limit speed thr	ms	INT32		1.000			RW	FVS

Setting of the speed threshold in the upper or lower limit zone.

Menu	PAR	Description	UM	Type	FB BIT	Def	Min	Max	Acc	Mod
5.9.11	11218	Spd target activity		INT16		1	0	5	RW	FVS

Setting of drive behaviour in case of the **Speed limit** alarm. This alarm is activated if, using the EFC function, the slow down distance is less than the real deceleration distance, thus enabling the speed limiter to ensure correct stopping.

- 0 Ignore
- 1 Warning
- 2 Disable
- 3 Fast Stop
- 4 Lift Fast stop
- 5 Lift stop

Menu	PAR	Description	UM	Type	FB BIT	Def	Min	Max	Acc	Mod
5.9.12	11264	Lift EF al activity		ENUM		5	0	5	RW	FVS

Setting of the "Lift external fault" alarm.

- 0 Ignora
- 1 Avvisa
- 2 Disable
- 3 Fast stop
- 4 Lift fast stop
- 5 Arresto lift

Menu	PAR	Description	UM	Type	FB BIT	Def	Min	Max	Acc	Mod
5.9.13	11266	Lift EF hold off	ms	LONG		1000	0	60000	RW	FVS

Maintaining the "Lift external fault" alarm.
"Lift EF" is displayed when a "Lift external fault" alarm occurs.

Menu	PAR	Description	UM	Type	FB BIT	Def	Min	Max	Acc	Mod
5.9.14	11268	Reset Brake Alarm		Short		0	-	-	RW	FVS

Resets the **Brake Alarm**.

1. Open menu 5.9 LIFT ALARMS, and check that the **Brake Alarm** is on.
2. In the lift alarm menu, select parameter 11268 **Reset Brake Alarm** (default 0).
3. The system asks for a code, enter release code 5313.
4. Check again to see whether the **Brake Alarm** has been reset.

Menu	PAR	Description	UM	Type	FB BIT	Def	Min	Max	Acc	Mod
5.9.15	11270	Threshold A3		Float		0.100	0.000	2.000	RW	FVS

When the brake is connected, the Brake fault alarm is activated if the movement (in metres) is more than the value set in parameter 11270 **Threshold A3**.

6 - [Redacted]

7 - [Redacted]

8 - [Redacted]

9 - [Redacted]

Note ! These menus are not available.

10 - DIGITAL INPUTS

Menu	PAR	Description	UM	Type	FB BIT	Def	Min	Max	Acc	Mod
10.01	1240	Dig inp 1X inversion			BIT	0	0	1	ERW	F__
10.02	1242	Dig inp 2X inversion			BIT	0	0	1	ERW	F__
10.03	1244	Dig inp 3X inversion			BIT	0	0	1	ERW	F__
10.04	1246	Dig inp 4X inversion			BIT	0	0	1	ERW	F__
10.05	1248	Dig inp 5X inversion			BIT	0	0	1	ERW	F__
10.06	1250	Dig inp 6X inversion			BIT	0	0	1	ERW	F__
10.07	1252	Dig inp 7X inversion			BIT	0	0	1	ERW	F__
10.08	1254	Dig inp 8X inversion			BIT	0	0	1	ERW	F__
10.09	1256	Dig inp 9X inversion			BIT	0	0	1	ERW	F__
10.10	1258	Dig inp 10X inversion			BIT	0	0	1	ERW	F__
10.11	1260	Dig inp 11X inversion			BIT	0	0	1	ERW	F__
10.12	1262	Dig inp 12X inversion			BIT	0	0	1	ERW	F__

Inversion of the logic status of the function associated with the digital input of the expansion card.

0 Off
1 On

Note !

The parameters **Dig inp 9X inversion ... Dig inp 12X inversion** are available only in the ADL300A version with a specific expansion card. See the ADL300 QS manual.

Menu	PAR	Description	UM	Type	FB BIT	Def	Min	Max	Acc	Mod
10.13	1268	Dig input E dest			ILINK	0	0	0	ER	F__
10.14	1270	Dig input 1X dest			ILINK	0	0	0	ER	F__
10.15	1272	Dig input 2X dest			ILINK	0	0	0	ER	F__
10.16	1274	Dig input 3X dest			ILINK	0	0	0	ER	F__
10.17	1276	Dig input 4X dest			ILINK	0	0	0	ER	F__
10.18	1278	Dig input 5X dest			ILINK	0	0	0	ER	F__
10.19	1280	Dig input 6X dest			ILINK	0	0	0	ER	F__
10.20	1282	Dig input 7X dest			ILINK	0	0	0	ER	F__
10.21	1284	Dig input 8X dest			ILINK	0	0	0	ER	F__
10.22	1286	Dig input 9X dest			ILINK	0	0	0	ER	F__
10.23	1288	Dig input 10X dest			ILINK	0	0	0	ER	F__
10.24	1290	Dig input 11X dest			ILINK	0	0	0	ER	F__
10.25	1292	Dig input 12X dest			ILINK	0	0	0	ER	F__

Selection of the destination of the digital input of the associated expansion card.

Note !

The parameters **Dig input 9X dest ... Dig input 12X dest** are available only in the ADL300A version with a specific expansion card. See the ADL300 QS manual.

11 - DIGITAL OUTPUTS

Menu	PAR	Description	UM	Type	FB BIT	Def	Min	Max	Acc	Mod
11.01	1410	Dig output 1X src		LINK	16BIT	1062	0	16384	ERW	F__
11.02	1412	Dig output 2X src		LINK	16BIT	3708	0	16384	ERW	F__
11.03	1414	Dig output 3X src		LINK	16BIT	3702	0	16384	ERW	F__
11.04	1416	Dig output 4X src		LINK	16BIT	3714	0	16384	ERW	F__
11.05	1418	Dig output 5X src		LINK	16BIT	1062	0	16384	ERW	F__
11.06	1420	Dig output 6X src		LINK	16BIT	3708	0	16384	ERW	F__
11.07	1422	Dig output 7X src		LINK	16BIT	3702	0	16384	ERW	F__
11.08	1424	Dig output 8X src		LINK	16BIT	3714	0	16384	ERW	F__

The destination associated with the digital input of the expansion card is displayed. The functions that can be associated with the digital outputs are listed in the "L_DIGSEL1" selection list".

Note !

The parameters **Dig output 5X src ... Dig output 8X src** are available only in the ADL300A version with a specific expansion card. See the ADL300 QS manual.

Menu	PAR	Description	UM	Type	FB BIT	Def	Min	Max	Acc	Mod
11.09	1430	Dig out 1X inversion			BIT	0	0	1	ERW	F__
11.10	1432	Dig out 2X inversion			BIT	0	0	1	ERW	F__
11.11	1434	Dig out 3X inversion			BIT	0	0	1	ERW	F__
11.12	1436	Dig out 4X inversion			BIT	0	0	1	ERW	F__
11.13	1438	Dig out 5X inversion			BIT	0	0	1	ERW	F__
11.14	1440	Dig out 6X inversion			BIT	0	0	1	ERW	F__
11.15	1442	Dig out 7X inversion			BIT	0	0	1	ERW	F__
11.16	1444	Dig out 8X inversion			BIT	0	0	1	ERW	F__

Inversion of the logic status of the function associated with the digital output of the expansion card.
0 Off
1 On

Note !

The parameters **Dig out 5X inversion ... Dig out 8X inversion** are available only in the ADL300A version with a specific expansion card. See the ADL300 QS manual.

12 - ANALOG INPUTS

Note ! These parameters are only available with cards provided with analog inputs.

Menu	PAR	Description	UM	Type	FB BIT	Def	Min	Max	Acc	Mod
12.1	1600	Analog input 1X mon	cnt	INT16	16/32BIT	0	0	0	ER	F__
12.13	1650	Analog input 2X mon	cnt	INT16	16/32BIT	0	0	0	ER	F__

The value of the voltage on the output of the function block of the relative analog input is displayed.

Menu	PAR	Description	UM	Type	FB BIT	Def	Min	Max	Acc	Mod
12.2	1602	Analog inp 1X type		ENUM		-10V..+10V	0	2	ERW	F__
12.14	1652	Analog inp 2X type		ENUM		-10V..+10V	0	2	ERW	F__

Selection of the type of input (voltage or current). Depending on the input signal, move the switches on the expansion card. The factory parameter is inputs set for differential voltage signals ($\pm 10V$).

- 0 -10V..+10V
- 1 0.20mA , 0.10V
- 2 4..20mA

Select option 0 in order to connect a maximum voltage of $\pm 12.5V$ (typically $\pm 10V/5mA$) to the analog input concerned. If the signal is used as a reference, reverse the direction of rotation by inverting the voltage polarity.

Select option 1 to connect a max voltage of 12.5V (typically 10V/5mA) or a signal in current from 0 ... 20 mA to the analog input concerned. The signal must be positive.

Select option 2 to connect a current signal of 4...20 mA to the analog input concerned. The signal must be positive.

Menu	PAR	Description	UM	Type	FB BIT	Def	Min	Max	Acc	Mod
12.3	1604	Analog inp 1X scale			FLOAT	1.0	-10.0	10.0	ERW	F__
12.15	1654	Analog inp 2X scale			FLOAT	1.0	-10.0	10.0	ERW	F__

Setting of a multiplier factor to be applied to the relative analog input of the expansion card.

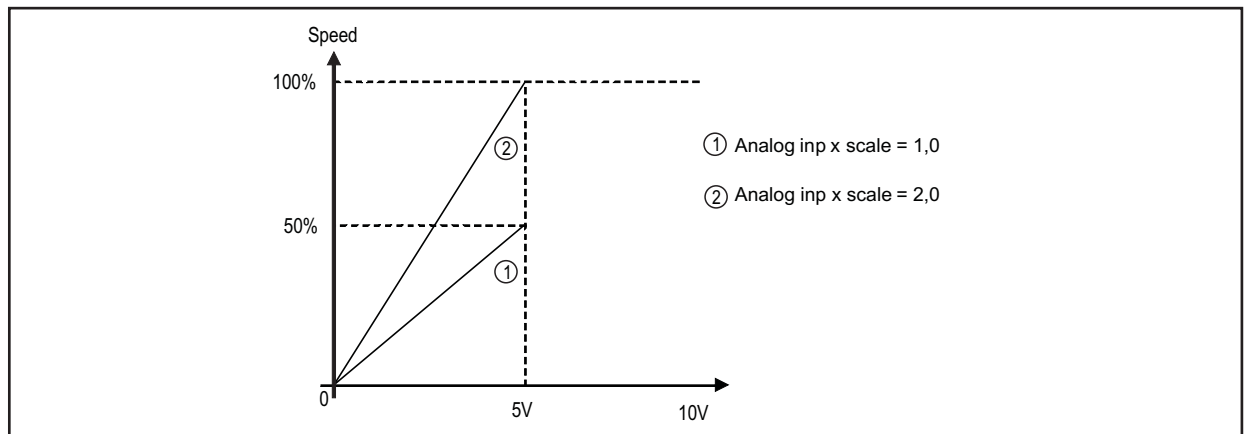

Example :

The speed reference of a drive is assigned with a max external voltage of 5V. With this value the drive must reach the maximum speed allowed (set using **Full scale speed**).

As the **Analog inp XX scale** parameter the scale factor of 2 is entered (10V : 5V)

Menu	PAR	Description	UM	Type	FB BIT	Def	Min	Max	Acc	Mod
12.4	1606	An inp 1Xoffset tune			BIT	0	0	1	ERW	F__
12.16	1656	An inp 2Xoffset tune			BIT	0	0	1	ERW	F__

Self-tuning command for the offset of the relative analog input of the expansion card. Automatic fine tuning of the input. To perform self-tuning, set the input signal to its minimum value and execute the command. The conditions containing an offset can be compensated. When this command is sent, **An inp xX offset tune** is automatically selected so that the available input signal corresponds to the zero value of the variable.

Automatic tuning can only be performed if the following condition is present:

- Input voltage less than 1V or input current less than 2 mA

NOTE!

The value that is obtained automatically can be changed manually, if necessary, using **An inp offset xX**.

If the voltage setting on the analog input is more than 1V the “Input value too high” message is displayed.

Menu	PAR	Description	UM	Type	FB BIT	Def	Min	Max	Acc	Mod
12.5	1608	An inp 1X gain tune			BIT	0	0	1	ERW	F__
12.17	1658	An inp 2X gain tune			BIT	0	0	1	ERW	F__

Self-tuning command for the relative analog input gain. Automatic fine tuning of the input. When this command is sent, **An inp XX gain tune** is automatically selected so that the available input signal corresponds to the maximum value of the variable.

Two conditions are necessary in order to perform automatic tuning:

- Input voltage greater than 1V or input current greater than 2 mA
- Positive polarity. The value that is found is automatically accepted for the other direction of rotation.

Note!

If necessary, the value obtained automatically can be changed manually via **An inp XX gain tune**.

To perform self-tuning, set the input signal to its maximum value and execute the command. A multiplier factor is calculated to apply to the input signal value (not considering the Analog inp scale parameter) to reach the full scale value.

If the voltage setting on the analog input is less than 1V the “Input value too low” message is displayed.

Menu	PAR	Description	UM	Type	FB BIT	Def	Min	Max	Acc	Mod
12.6	1610	Analog inp 1X filter	ms		UINT16	10	2	100	ERW	FVS
12.18	1660	Analog inp 2X filter	ms		UINT16	10	2	100	ERW	FVS

Filter on the measurement of the corresponding analog input. This parameter can be used to control the response of the analog input and reduce any possible noise and interference.

Menu	PAR	Description	UM	Type	FB BIT	Def	Min	Max	Acc	Mod
12.7	1612	Analog inp 1X top	cnt		INT16	16384	-32768	+32767	ERW	FVS
12.19	1662	Analog inp 2X top	cnt		INT16	16384	-32768	+32767	ERW	FVS

Setting of the upper speed reference limit as a function of the voltage (or current) of the relative analog reference of the expansion card.

Menu	PAR	Description	UM	Type	FB BIT	Def	Min	Max	Acc	Mod
12.8	1614	Analog inp 1X bottom	cnt		INT16	-16384	-32768	+32767	ERW	FVS
12.20	1664	Analog inp 2X bottom	cnt		INT16	-16384	-32768	+32767	ERW	FVS

Setting of the lower speed reference limit as a function of the voltage (or current) of the relative analog reference of the expansion card.

Menu	PAR	Description	UM	Type	FB BIT	Def	Min	Max	Acc	Mod
12.9	1616	Analog inp 1X offset	cnt		INT16	0	-32768	+32767	ERW	FVS
12.21	1666	Analog inp 2X offset	cnt		INT16	0	-32768	+32767	ERW	FVS

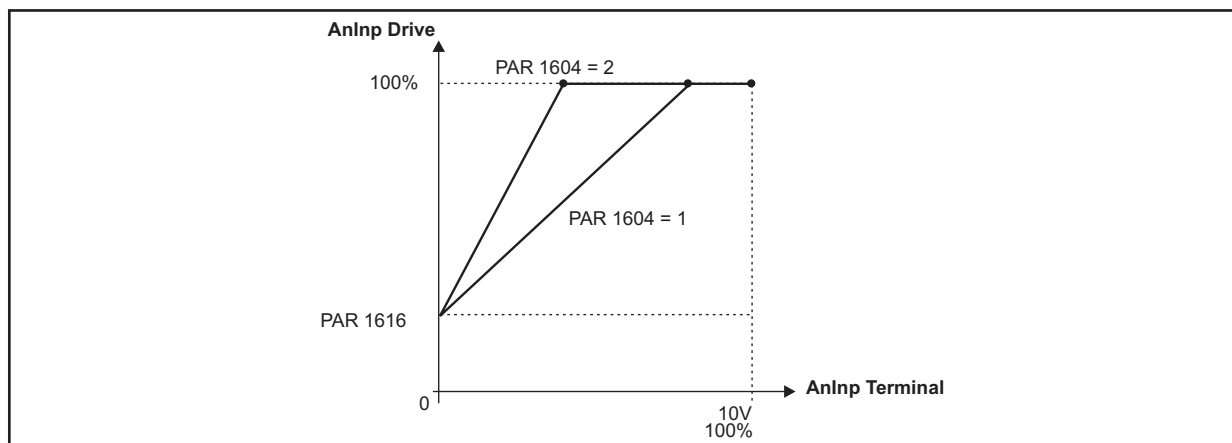

Setting of an offset value to algebraically add to the relative analog input of the expansion card.

Menu	PAR	Description	UM	Type	FB BIT	Def	Min	Max	Acc	Mod
12.10	1618	Analog inp 1X gain			FLOAT	1.0	-10.0	10.0	ERW	FVS
12.22	1668	Analog inp 2X gain			FLOAT	1.0	-10.0	10.0	ERW	FVS

This parameter contains the value of the multiplier factor to apply to the analog reference of the expansion card calculated using the **Analog inp gain tune** function.

Example :

An external analog reference only reaches a maximum of 9.8V instead of 10V. 1.020 (10V : 9.8V) is entered as the **Analog inp x gain** parameter.

The same result can be achieved using the **Analog inp x gain tune** function. This parameter can be selected from the keypad menu. The maximum analog value available (in this case 9.8V) must be present on the terminal, with positive polarity. Press the **Enter** key on the keypad to start analog reference self-tuning.

Menu	PAR	Description	UM	Type	FB BIT	Def	Min	Max	Acc	Mod
12.11	1626	An inp 1X sign src		LINK	16BIT	6000	0	16384	ERW	FVS
12.23	1676	An inp 2X sign src		LINK	16BIT	6000	0	16384	ERW	FVS

Selection of the origin (source) of the signal to be assigned to the relative digital input of the expansion card for selecting the direction of rotation of the motor. The functions that can be associated with the digital outputs are listed in the "**L_DIG-SEL2**" selection list".

Menu	PAR	Description	UM	Type	FB BIT	Def	Min	Max	Acc	Mod
12.12	1632	Analog input 1X dest		ILINK		0	0	0	ER	FVS
12.24	1682	Analog input 2X dest		ILINK		0	0	0	ER	FVS

The function for which the relative analog input of the expansion card has been programmed and on which it acts is displayed.

13 - ANALOG OUTPUTS

There can be two programmable analog outputs, depending on the configuration.

Analog output 1 supplies a two-pole +/-10VDC voltage signal, while analog output 2 can be programmed to obtain a 0-20mA or 4-20mA output signal in current or a signal in two-pole +/-10VDC voltage, depending on the parameter assigned.

Note ! These parameters are only available with cards provided with analog outputs.

Menu	PAR	Description	UM	Type	FB BIT	Def	Min	Max	Acc	Mod
13.1	1850	Analog out 1X src		LINK	16/32BIT	6000	0	16384	ERW	F__
13.2	1852	Analog out 2X src		LINK	16/32BIT	6000	0	16384	ERW	F__

Selection of the origin (source) of the signals that can be placed as variables on the analog outputs of the expansion card. The functions that can be assigned to the analog outputs are listed in the "L_ANOUT" selection list".

Menu	PAR	Description	UM	Type	FB BIT	Def	Min	Max	Acc	Mod
13.3	1858	Analog out 1X scale		FLOAT		1.0	-10.0	10.0	ERW	F__
13.4	1860	Analog out 2X scale		FLOAT		1.0	-10.0	10.0	ERW	F__

Parameter for setting a multiplier factor of the signal of the relative analog output of the expansion card. It can be used to amplify or reduce the input value of the relative analog output block.

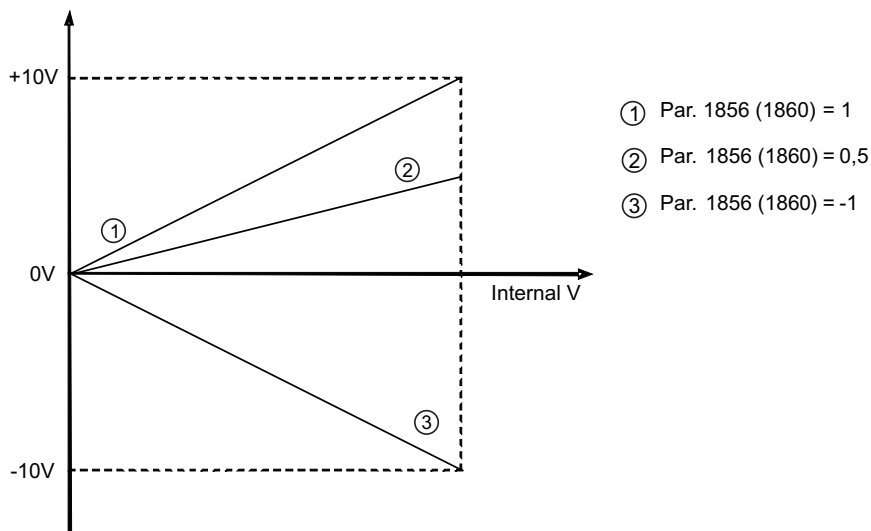

$$V_{out} = 10 \times \left(\frac{Stp\ Var \times par.\ 1858\ (1860)}{FS\ Var} \right)$$

- Vout** output voltage on the card terminals.
- Stp Var** actual value of the variable (variable unit)
- FS Var** full scale of the variable (variable unit)

Example of calculation of the Analog out Xx scale factor

To display the drive speed, use an analog instrument with field of measurement from 0 ... 2V. This means that, to display the speed of the drive, a voltage of 2V on the analog output of the drive must correspond to the maximum speed. With a scale factor of 1 this would be 10V (Scale factor = 2V / 10 V = 0.200).

Menu	PAR	Description	UM	Type	FB BIT	Def	Min	Max	Acc	Mod
13.5	1866	Analog out 1X mon	cnt		INT16	0	0	0	ER	F__

The actual value of the voltage present on analog output 1 of the expansion card is displayed.

Menu	PAR	Description	UM	Type	FB BIT	Def	Min	Max	Acc	Mod
13.6	1868	Analog out 2X mon	cnt		INT16	0	0	0	ER	F__

The actual value of the voltage or current present on analog output 2 of the expansion card is displayed.

Menu	PAR	Description	UM	Type	FB BIT	Def	Min	Max	Acc	Mod
13.7	1874	An out 1X absolute		ENUM	INT16	Disable	0	1	ERW	F__
13.8	1876	An out 2X absolute		ENUM	INT16	Disable	0	1	ERW	F__

Enables the relative analog output as an absolute value. If this parameter is set to 1 the voltage on the analog output assumes the value of 0...10V regardless of the sign of the command signal.

- 0** Disable
- 1** Enable

Menu	PAR	Description	UM	Type	FB BIT	Def	Min	Max	Acc	Mod
13.9	1882	Analog out 1X min	cnt		INT16	-16384	-32768	+32767	ERW	F__
13.10	1884	Analog out 1X max	cnt		INT16	-16384	-32768	+32767	ERW	F__

Setting of the minimum and maximum values for the analog output for the voltage present on analog output 1 of the expansion card.

Menu	PAR	Description	UM	Type	FB BIT	Def	Min	Max	Acc	Mod
13.11	1890	Analog out 2X min	cnt		INT16	-16384	-32768	+32767	ERW	F__
13.12	1892	Analog out 2X max	cnt		INT16	16384	-32768	+32767	ERW	F__

Setting of the minimum and maximum values for the analog output in current or voltage present on analog output 2 of the expansion card.

Menu	PAR	Description	UM	Type	FB BIT	Def	Min	Max	Acc	Mod
13.13	1898	Analog out 2X type		ENUM		-10V..+10V	0	2	ERW	F__

Selection of the programmed signal on analog output 2 of the expansion card. The standard output is coded for the signal in voltage.

- 0** 0..20mA
- 1** 4..20mA
- 2** -10V..+10V

Select option 0 to apply a signal in current of 0 ... 20 mA to analog output 2. The signal must be positive.

Select option 1 to apply a signal in current of 4...20 mA to analog output 2.

Select option 2 to apply a maximum voltage of $\pm 12.5V$ (typically $\pm 10V/5mA$) to analog output 2.

14 - MOTOR DATA

From this menu you can enter the motor plate data and “basic” values for the voltage/frequency characteristics. It is important to enter the correct data in order to optimize drive operation and that of the application as a whole. These data are required in order to obtain:

- a) Computation of the normalization factors necessary for regulation
- b) Computation of the estimated values for the motor parameters necessary for regulation

Rated voltage, Rated speed and Rated current must be entered.

After entering these parameters, send a **Take parameters** command to calculate (a) and (b) above. The motor cannot be enabled until the **Take parameters** command has been set. If some results are inconsistent, or if the motor is much smaller than the inverter, an error message is displayed indicating a numerical capacity overflow and the previous set of parameters is restored in the “**Mot plate data**” sub-menu.

Example of kW and HP motor data plates

Motor & Co.		Brushless Servomotor	
Type: ABCDE	Nr 12345-9	Pn 9.614 kW	
To 48 Nm	lo 20.4 A	Vn 299 V	Speed 2000 rpm
Tn 46 Nm	In 19.6 A	Ipk 51 A	Duty S1
Jm 6 gm ²	Kt 2.35 Nm/A	Fan 220 V	IP 54
Feedback RE 21-1-V32	Brake / Nm / Vdc		
Ins class F IEC34-1 Pt130°C Ph3	Poles 8	Weight 38 kg	
Made in			

Menu	PAR	Description	UM	Type	FB BIT	Def	Min	Max	Acc	Mod
14.1	2000	Rated voltage	V	FLOAT		SIZE	50.0	690.0	RWZS	F__
Set the motor rated voltage as indicated on the data plate. This is the voltage the drive must supply at the motor rated frequency.										

Menu	PAR	Description	UM	Type	FB BIT	Def	Min	Max	Acc	Mod
14.2	2002	Rated current	A	FLOAT		SIZE	1.0	1500.0	RWZS	F__
The motor rated current at its rated power (kW / Hp) and voltage (indicated on the motor data plate). If using a single drive to control several motors connected in parallel (only possible in the SSC mode), enter a value that corresponds to the sum of the rated currents of all the motors; in this case do not perform any “self-tuning operations”.										

Menu	PAR	Description	UM	Type	FB BIT	Def	Min	Max	Acc	Mod
14.3	2004	Rated speed	rpm	FLOAT		SIZE	10.0	32000.0	RWZS	F__
Rated speed of the motor with full load in rpm. It can be calculated by dividing the torque constant by $\sqrt{3}$ with appropriate scaling.										

Menu	PAR	Description	UM	Type	FB BIT	Def	Min	Max	Acc	Mod
14.4	2008	Pole pairs		UINT16		SIZE	1	60	RWZS	F__
Setting of the number of motor pole pairs.										

Menu	PAR	Description	UM	Type	FB BIT	Def	Min	Max	Acc	Mod
14.5	2010	Torque constant	Nm/A	FLOAT		SIZE	0.1	120.0	RWZS	F__
Setting of the ratio between the torque generated and the rated current of the motor.										

Menu	PAR	Description	UM	Type	FB BIT	Def	Min	Max	Acc	Mod
14.6	2012	EMF constant	Wb	FLOAT		SIZE	0.0	100.0	RWZS	F__
Setting of the electromotive force constant, which represents the ratio between the motor voltage and its rated speed (this can be calculated by dividing the torque constant by $\sqrt{3}$)										

Menu	PAR	Description	UM	Type	FB BIT	Def	Min	Max	Acc	Mod
14.7	2020	Take parameters		BIT		0	0	1	RWZ	F__
<p>Saves the set motor data in the drive. This command must be supplied last after entering the appropriate values of all the parameters listed above. This means calculating the normalization factors (a) and estimated values for the motor parameters (b). The drive cannot be started until the Take parameters command has been set.</p>										
14.8	2024	Autotune still		BIT		0	0	1	RWZ	F__
<p>Performs self-tuning with the motor coupled to the transmission. The self-tuning procedure may cause limited rotation of the motor shaft. To perform self-tuning, follow the procedure described for the previous parameter.</p>										
14.9	2028	Take status		ENUM		Required	0	0	R	F__
<p>Indication of the status of parameter saving.</p> <p>0 Required 1 Done</p> <p>The parameter displays the Required message when the motor parameters that have been entered need to be saved. When they have been saved the parameter indicates Done.</p>										
14.10	2030	Autotune status		ENUM		Required	0	0	R	F__
<p>Indication of the status of execution of motor parameter self-tuning.</p> <p>0 Required 1 Done</p> <p>The parameter displays the Required message when motor parameter self-tuning is required. When self-tuning is complete the parameter indicates Done.</p>										
14.11	2050	Measured Rs	ohm	FLOAT		CALCF	0.001	200.0	ERWS	F__
<p>Measured value of the rotor resistance.</p>										
14.12	2052	Measured DTL	V	FLOAT		0.0	0.0	100.0	ERWS	F__
<p>Measured value of dead time compensation.</p>										
14.13	2054	Measured DTS	V/A	FLOAT		0.0	0.0	100.0	ERWS	F__
<p>Measured compensation gradient value.</p>										
14.14	2056	Measured Lsig	mH	FLOAT		CALCF	0.1	200.0	ERWS	F__
<p>Measured leakage inductance value.</p>										
14.15	2074	Lsig min misurata	mH	FLOAT		CALCF	0.1	300.0	ERWS	F__
<p>Value of minimum inductance leakage measured during autotuning.</p>										
14.16	2078	Take tune parameters		BIT		0	0	1	ERWZ	F__
<p>Saves the motor data calculated by the self-tuning procedure in the drive.</p>										

Note!

Data are not saved permanently. Use the **"Save Parameters"** command in the DRIVE CONFIG menu to save in the permanent memory.

Menu	PAR	Description	UM	Type	FB BIT	Def	Min	Max	Acc	Mod
14.17	680	Full scale speed	rpm	INT16		CALCI	50	32000	RWZ	FVS

Setting of the reference value for all speed percentage data (References, Speed adaptives ...) corresponding to 100 % of the actual speed. This parameter can only be changed with the inverter blocked (Enable drive = Disabled). The recommended setting for the value of this parameter is the motor rated speed. If altered, the self-tuning procedure should be repeated.

Full scale speed does not define the maximum possible speed. In any case, the maximum speed percentage value is ± 200 % of the **Full scale speed** value.

15 - ENCODER CONFIG

The closed-loop control mode requires a speed reading by an encoder on the motor shaft. The card is necessary in order to acquire the encoder signals. In the synchronous mode, encoder feedback is essential for correct drive operation.

Note ! This menu is only displayed if a feedback card is installed

Menu	PAR	Description	UM	Type	FB BIT	Def	Min	Max	Acc	Mod
15.1	2100	Encoder pulses	ppr	UINT16		1024	128	16384	RWZ	F__

Setting of the number of feedback encoder impulses. During setup, for incremental sinusoidal encoders + absolute EnDat, encoder absolute EnDat Full digital and Hiperface encoders this value is set automatically by reading the number of incremental encoder impulses.

With the EnDat Full digital Encoder, the value set automatically may be below the minimum.

Menu	PAR	Description	UM	Type	FB BIT	Def	Min	Max	Acc	Mod
15.2	2102	Encoder supply	V	FLOAT		5.2	5.2	CALCF	ERWZ	F__

Setting of the encoder supply voltage supplied by the relative optional card. Min and max values are modified according to the type of encoder card applied.

Type of encoder option		Def	Min	Max
Enc 1	EXP-DE-I1R1F2-ADL	5.2 V	5.2 V	22.0 V
Enc 2	EXP-SE-I1R1F2-ADL	5.2 V	5.2 V	6.0 V
Enc 3	EXP-SESC-I1R1F2-ADL	5.2 V	5.2 V	6.0 V
Enc 4	EXP-EN/SSI-I1R1F2-ADL	5.2 V	5.2 V	10.0 V
Enc 5	EXP-HIP-I1R1F2-ADL	8.0 V	7.0 V	12.0 V

Menu	PAR	Description	UM	Type	FB BIT	Def	Min	Max	Acc	Mod
15.3	2104	Encoder input config		ENUM		TTL	0	1	ERWZ	F__

Setting of the input configuration of the incremental digital encoder, TTL or HTL.

- 0 HTL
- 1 TTL

This parameter is automatically set to HTL when the value set in the **Encoder supply** parameter is more than 6.0V.

Menu	PAR	Description	UM	Type	FB BIT	Def	Min	Max	Acc	Mod
15.4	2106	Encoder repetition		ENUM		No division	0	3	ERWZ	F__

Setting of the divider to apply to the encoder repeat output frequency.

- 0 No division
- 1 Divide 2
- 2 Divide 4
- 3 Divide 8

Menu	PAR	Description	UM	Type	FB BIT	Def	Min	Max	Acc	Mod
15.5	2108	Encoder signal Vpp	V	FLOAT		1	0.8	1.2	ERWZ	F__

Setting of the peak-to-peak voltage value of the encoder signal. Incremental sinusoidal encoders and absolute SinCos encoders normally produce signals with a peak-to-peak voltage of 1 Vpp. Due to loss of voltage along the cable, the value of the peak-to-peak voltage signal received by the feedback card could be lower, generating a **Speed fbk loss** alarm.

This parameter can be used to set the peak-to-peak voltage value of the incremental sinusoidal encoders and absolute SinCos encoders on the input terminals of the feedback card.

Menu	PAR	Description	UM	Type	FB BIT	Def	Min	Max	Acc	Mod
15.6	2110	Encoder signal check		ENUM		Check A-B	0	3	ERWZ	F__

Configuration of which incremental digital encoder channels are to be controlled in order to process the **Speed fbk loss** alarm signal.

- 0 Check disabled
- 1 Check A-B
- 2 Check A-B-Z

- 3 Check A-B-Z-P
- 4 Check A-B-SE

Set **1** to check for signal on channels A-B

Set **2** to check for signal on channels A-B-Z

Set **3** to check for signal on channels A-B-Z and the expected number of pulses per revolution.

If set to **4**, the application controls loss of feedback for SE (single ended) encoders.

If the application detects the absence of feedback the **Speed fbk loss** [22] is generated.

As loss of feedback cannot be detected at speeds of around zero, the control is only performed if the speed reference is higher than the value set in parameter **4564 SpdFbkLoss threshold**. It is also important to consider the fact that when working with a speed reference slightly above the limit set in parameter **4564 SpdFbkLoss threshold**, the speed error could exceed the set threshold, given the load or current limit, and generate false alarms.

In that case increase the value of parameter **4550 SpdRefLoss threshold** or of parameter **4554 SpdRefLoss holdoff**.

Menu	PAR	Description	UM	Type	FB BIT	Def	Min	Max	Acc	Mod
15.7	2112	Encoder SSI bits		UINT16		25	13	25	ERWZ	F__
Setting of the length of the SSI package, defined as the number of clock cycles, in that the packages of the absolute SSI encoders available on the market vary in length from 13 to 25 bits.										

Menu	PAR	Description	UM	Type	FB BIT	Def	Min	Max	Acc	Mod
15.8	2114	Encoder SSI pos bits		UINT16		25	11	25	ERWZ	FVS
This parameter sets the number of position bits of SSI encoder.										

Menu	PAR	Description	UM	Type	FB BIT	Def	Min	Max	Acc	Mod
15.9	2130	Encoder direction		ENUM		Not inverted	0	1	RWZ	F__
Setting of the sign of the information obtained from the incremental or absolute encoder.										
0 Not inverted										
1 Inverted										

By setting 0 the encoder feedback signals are not inverted.

By setting 1 the encoder feedback signals are inverted

According to international standards, positive references are associated with clockwise motor rotation, seen from the control side (shaft). To ensure correct operation, the regulation algorithms ensure that positive speed references correspond to positive speed measurements.

If the motor pulley is mounted on the side opposite the command side, it will turn in an anticlockwise direction when the speed is positive: to make the pulley turn in a clockwise direction, the motor phase sequence is modified, which inverts the speed measurement sign. To restore the correct speed measurement sign, invert the incremental encoder A+ and A- signals and the absolute encoder Sin+ and Sin- signals on the encoder connections. The absolute part cannot be inverted with Endat and Hiperface absolute encoders.

Menu	PAR	Description	UM	Type	FB BIT	Def	Min	Max	Acc	Mod
15.10	2132	Encoder mode		ENUM		Sinus SINCOS	CALCI	CALCI	ERWZ	F__
ADL300B: The drive has an integrated encoder card (SinCos & Incremental TTL Encoder). The encoder mode can be selected in accordance with the following table:										
0 None										
1 Digital FP										
2 Digital F										
3 Sinus SINCOS (Default)										
5 Sinus ENDAT										
6 Sinus SSI										
7 Sinus HIPER										
8 ENDAT										

Nota: There is no need to restart the drive when the mode is changed.

ADL300 Basic with Digital FP / Digital F / Sinus / Sinus SINCOS encoder and ADL300 Basic with Sinus ENDAT / Sinus SSI encoder have different commercial codes (see ADL300 catalog).

ADL300A: the drive supports different types of encoder cards. The mode can only be selected if an incremental digital encoder card is used. If an EN/SSI encoder card is used, the mode is automatically set by the drive in accordance with the

type of encoder detected. For all other encoder cards, the mode is set in accordance with the card used. The modes are listed in the following table:

		Encoder Card
0	None	
1	Digital FP	EXP-DE-I1R1F2-ADL
2	Digital F (Default)	EXP-DE-I1R1F2-AD
3	Sinus	EXP-SE-I1R1F2-ADL
4	Sinus SINCOS	EXP-SESC-I1R1F2-ADL
5	Sinus ENDAT	EXP-EN/SSI-I1R1F2-ADL (*)
6	Sinus SSI	EXP-EN/SSI-I1R1F2-ADL (*)
7	Sinus HIPER	EXP-HIP-I1R1F2-ADL
8	ENDAT	EXP-EN/SSI-I1R1F2-ADL (*)

(*) The card automatically selects the correct mode in relation to the encoder type.

Menu	PAR	Description	UM	Type	FB BIT	Def	Min	Max	Acc	Mod
15.11	2136	PeripheralEncoder		BIT		0	0	1	ERW	F__

0 No
1 Yes

This parameter lets you select if the encoder is positioned on the tangent of the motor rotor. If you select 1, see Appendix 2.

Nota!

If peripheral encoder (option = 1) is selected, the parameter 4552 (SpdRefLoss activity) in the menu ALARM CONFIG must be set to DISABLE.

Menu	PAR	Description	UM	Type	FB BIT	Def	Min	Max	Acc	Mod
15.12	2134	Encoder speed filter	ms	FLOAT		2.0	0.1	20.0	ERW	F__

Setting of the time constant of the filter applied to the feedback encoder pulse reading. The parameter affects both the accuracy of the speed measurement and the dynamics obtainable in closed loop control. On the other hand, the use of a speed measurement filter introduces delays that do not permit high control loop dynamics. Low settings extend the regulation bandwidth but may accentuate any disturbance. The filter is applied to the speed reported in the **Encoder speed** parameter.

Menu	PAR	Description	UM	Type	FB BIT	Def	Min	Max	Acc	Mod
15.13	2184	Ext motor diam		UINT16		1	1	65535	ERWZ	F__

This is the diameter D of the motor rotor. It must be set only if you use a peripheral encoder (PAR 2136). See appendix 2.

Menu	PAR	Description	UM	Type	FB BIT	Def	Min	Max	Acc	Mod
15.14	2186	Enc pulley diam		UINT16		1	1	65535	ERWZ	F__

This is the diameter d of the incremental encoder pulley. It must be set only if you use a peripheral encoder (PAR 2136). See appendix 2.

Menu	PAR	Description	UM	Type	FB BIT	Def	Min	Max	Acc	Mod
15.15	2084	Theta est kp		FLOAT		0.005	0.0	9999.0	ERW	F__

By this parameter it is possible to tune the tuning for the encoder compensation.

Menu	PAR	Description	UM	Type	FB BIT	Def	Min	Max	Acc	Mod
15.16	2090	EMF speed correction	perc	FLOAT		5.0	0.0	200.0	ERW	F__

By this parameter it is possible to tune the speed value for the compensation set by parameter 2084. Above this speed the compensation is executed.

Menu	PAR	Description	UM	Type	FB BIT	Def	Min	Max	Acc	Mod
15.17	2150	Encoder speed	rpm	INT16	16/32BIT	0	0	0	ER	F__

The motor speed measured by the incremental encoder is displayed, filtered by the **Encoder speed filter** parameter.

Menu	PAR	Description	UM	Type	FB BIT	Def	Min	Max	Acc	Mod
15.18	2162	Encoder position	cnt	UINT16	16BIT	0	0	0	ER	F__

The impulse count obtained from the **incremental** encoder reading is displayed: 1 encoder turn is equal to the value entered in Encoder pulses multiplied by 4.

Menu	PAR	Description	UM	Type	FB BIT	Def	Min	Max	Acc	Mod
15.19	2172	SpdFbkLoss code		UINT32		0	0	0	ER	F__

The **Speed fbk loss** alarm generated by an encoder fault is displayed. Each type of encoder generates the alarm differently (incremental signal error, absolute signal error, serial error), so this parameter is used to display information about the alarm that has been activated. In case of several concurrent causes, these are shown in this parameter.

Bit	Value	Name
0	0x01	CHA
1	0x02	CHB
2	0x04	CHZ
3	0x08	MOD_INCR
4	0x10	MOD_ABS
5	0x20	CRC_CKS_P
6	0x40	ACK_TMO
7	0x80	DT1_ERR
8	0x100	Setup error
10..15		Free
16..31		Depends on the encoder

For further details reference should be made to the description of the **Speed fbk loss** alarm and to the SFL alarms chapter according to the type of feedback.

Note !

For the correct interpretation of the cause of the alarm trigger, it is necessary to transform the hex code indicated in parameter 15.17 SpdFbkLoss code, PAR 2172, in the corresponding binary and verify in the encoder table that the active bits and related description are used.

Example with encoder Endat:

PAR 2172 = A0H (hex value)

In the table "**Speed fbk loss [22] alarm with absolute encoder EnDat**" A0 is not indicated in the value column.

A0 should be contemplated as a bitword with meaning A0 -> 10100000 -> bit 5 and bit 7. The following causes simultaneously intervene:

Bit 5 = 20H Cause: the SSI signal interferences cause an error in the CKS or parity

Bit 7 = 80H Cause: The encoder has detected an incorrect operation and communicates it to the converter through the Error bit. Bits 16..31 present the type of incorrect encoder operation detected.

Menu	PAR	Description	UM	Type	FB BIT	Def	Min	Max	Acc	Mod
15.20	2176	Encoder sync mode		UINT16		1	0	3	ERWZ	F__

Setting of the rate of synchronisation between incremental and absolute tracks.

If set to **0** synchronisation is only performed once at power on.

If set to **1** synchronisation is performed each time the start command is entered.

If set to **2** synchronisation is performed every 128 ms.

If set to **3** synchronisation is always performed, using the absolute section.

This function can only be used with absolute encoders and the default, minimum and maximum values are modified according to the type of encoder.

Type of encoder option	Def	Min	Max
Enc 1	1	0	3
Enc 2	1	0	3
Enc 3	1	0	3
Enc 4	1	0	3
Enc 5	1	0	1

Menu	PAR	Description	UM	Type	FB BIT	Def	Min	Max	Acc	Mod
15.21	2190	Autophase rotation		BIT		0	0	1	RWZ	F__

This parameter can be set to perform encoder phasing with the motor turning: the motor must be free to turn and with no load applied (the brake must be released). This procedure allows the greatest degree of accuracy.

In order to execute the command:

- open the enable command (Enable).
- set this parameter to 1 (for commands sent via serial communication)
- Press Enter to confirm (if sending commands from the keypad)
- when asked to close the enabling contact apply the command to terminal 9 (Enable)
- at the end of the procedure you will be asked to re-open the enabling contact (Enable) to confirm completion.

Note !

See section A3.2 of the Appendix to the Quick start guide for further information.

Menu	PAR	Description	UM	Type	FB BIT	Def	Min	Max	Acc	Mod
15.22	2192	Autophase still		BIT		0	0	1	RWZ	F__

This parameter can be set to perform encoder phasing without the motor running: the brake must be closed.
In order to execute the command:

- open the enable command (Enable).
- set this parameter to 1
- press Enter to confirm
- when prompted to close the enabling contact apply the command to terminal 9 (Enable)
- at the end of the procedure you will be asked to open the enabling contact (Enable) again to confirm completion.

Note !

See section A3.2 of the Appendix to the Quick start guide for further information.

Menu	PAR	Description	UM	Type	FB BIT	Def	Min	Max	Acc	Mod
15.23	2194	Autophase still mode		ENUM		Modo 1	0	1	ERW	F__

You can select two different static phasing methods based on the different characteristics of synchronous motors on the market. We recommend using **Mode 1** as the first option. If **Mode 1** does not run correctly, the motor (due to its constructive characteristics) requires a different mode (i.e., **Mode 2**).

- 0 **Mode 1**
- 1 **Mode 2**

Menu	PAR	Description	UM	Type	FB BIT	Def	Min	Max	Acc	Mod
15.24	2196	Autophase still run		ENUM		First enable	1	3	ERWZ	F__

The encoder phasing procedure is run as follows:

- 1 **First enable** first time enable is received after start
- 2 **Each enable** each time the drive receives an enable signal
- 3 **Periodically** periodically at nth enable signal configurable with PAR 2198.

Menu	PAR	Description	UM	Type	FB BIT	Def	Min	Max	Acc	Mod
15.25	2198	Autophase cnt enable		UINT16		50	2	65535	ERWZ	F__

Defines the number of enable signals (trips) after which encoder phasing must start.

16 - SPEED REG GAINS

The speed adaptive allows different speed regulator gains to be obtained according to the speed or another value. The behaviour of the speed regulator can thus be configured in the best way for the specific application requirements.

Note ! Current, flux and voltage regulators can be set using the self-tuning procedure. If this is not successful, current and flux regulators can be tuned manually (this does not apply to voltage regulators, which must not be modified by the user). The speed regulator must be tuned manually. Gains are usually adjusted according to the drive speed.

Total gains used by the speed regulator are calculated as shown in the following examples. Results are in engineering units:

$$\text{Total proportional gain} = \frac{\text{Speed reg P1 gain (PAR 2200)}}{100\%} * \text{Speed reg P gain (PAR 2236)}$$

$$\text{Total integral gain} = \frac{\text{Speed reg I1 gain (PAR 2202)}}{100\%} * \text{Total proportional gain} * \frac{1}{\text{Speed reg I time (PAR 2238)}}$$

Menu	PAR	Description	UM	Type	FB BIT	Def	Min	Max	Acc	Mod
16.1	2200	Speed reg P1 gain	perc	INT16		100	0	1000	RW	F__
Setting of the proportional gain of the speed regulator, set 1.										

Menu	PAR	Description	UM	Type	FB BIT	Def	Min	Max	Acc	Mod
16.2	2202	Speed reg I1 gain	perc	INT16		100	0	1000	RW	F__
Setting of the integral gain of the speed regulator, set 1. Increasing the proportional gain value increases the proportional action of the regulator										

Menu	PAR	Description	UM	Type	FB BIT	Def	Min	Max	Acc	Mod
16.3	2204	Speed reg P2 gain	perc	INT16		100	0	1000	RW	F__
Setting of the proportional gain of the speed regulator, set 2.										

Menu	PAR	Description	UM	Type	FB BIT	Def	Min	Max	Acc	Mod
16.4	2206	Speed reg I2 gain	perc	INT16		100	0	1000	RW	F__
Setting of the integral gain of the speed regulator, set 2. Increasing the proportional gain value increases the proportional action of the regulator										

Menu	PAR	Description	UM	Type	FB BIT	Def	Min	Max	Acc	Mod
16.5	2208	Speed reg P3 gain	perc	INT16		100	0	1000	ERW	F__
Setting of the proportional gain of the speed regulator, set 3.										

Menu	PAR	Description	UM	Type	FB BIT	Def	Min	Max	Acc	Mod
16.6	2210	Speed reg I3 gain	perc	INT16		100	0	1000	ERW	F__
Setting of the integral gain of the speed regulator, set 3. Increasing the proportional gain value increases the proportional action of the regulator.										

Menu	PAR	Description	UM	Type	FB BIT	Def	Min	Max	Acc	Mod
16.7	2228	Speed reg P0 gain	perc	INT16		100	0	1000	ERW	F__
Setting of the proportional gain of the speed regulator at zero speed.										

Menu	PAR	Description	UM	Type	FB BIT	Def	Min	Max	Acc	Mod
16.8	2230	Speed reg I0 gain	perc	INT16		100	0	1000	ERW	F__
Setting of the integral gain of the speed regulator at zero speed. Increasing the proportional gain value increases the proportional action of the regulator										

Menu	PAR	Description	UM	Type	FB BIT	Def	Min	Max	Acc	Mod
16.9	2218	Gain adp spd thr2_1	perc	FLOAT		85.0	0.0	100.0	ERW	F__
Setting of the speed threshold for changing gains from set 1 to set 2.										

Menu	PAR	Description	UM	Type	FB BIT	Def	Min	Max	Acc	Mod
16.10	2220	Gain adp spd band2_1	perc	FLOAT		5.0	0.0	100.0	ERW	F__
Setting of the band within which gains vary between set 1 and set 2. The use of this parameter ensures a smooth transition between the two parameter sets.										

Menu	PAR	Description	UM	Type	FB BIT	Def	Min	Max	Acc	Mod
16.11	2222	Gain adp spd thr3_2	perc	FLOAT		2.0	0.0	100.0	ERW	F__

Setting of the speed threshold for changing gains from set 3 to set 2.

Menu	PAR	Description	UM	Type	FB BIT	Def	Min	Max	Acc	Mod
16.12	2224	Gain adp spd band3_2	perc	FLOAT		1.0	0.0	100.0	ERW	F__

Setting of the band within which gains vary between set 3 and set 2. The use of this parameter ensures a smooth transition between the two parameter sets.

Menu	PAR	Description	UM	Type	FB BIT	Def	Min	Max	Acc	Mod
16.13	2246	Gain adp spd thr0_2	perc	FLOAT		1.0	0.0	100.0	ERW	F__

Setting of the speed threshold for changing gains from set 0 to set 2.

Menu	PAR	Description	UM	Type	FB BIT	Def	Min	Max	Acc	Mod
16.14	2248	Gain adp spd band0_2	perc	FLOAT		0.3	0.0	100.0	ERW	F__

Setting of the band within which gains vary between set 0 and set 2. The use of this parameter ensures a smooth transition between the two parameter sets.

Menu	PAR	Description	UM	Type	FB BIT	Def	Min	Max	Acc	Mod
16.15	2244	Gain profile mode		ENUM		Profile 0213	0	3	ERW	F__

Gain profile modes.

- 0 Profile 1
- 1 Profile 21
- 2 Profile 321
- 3 Profile 0213

- If set to 0 the profile used is that shown in the figure below:

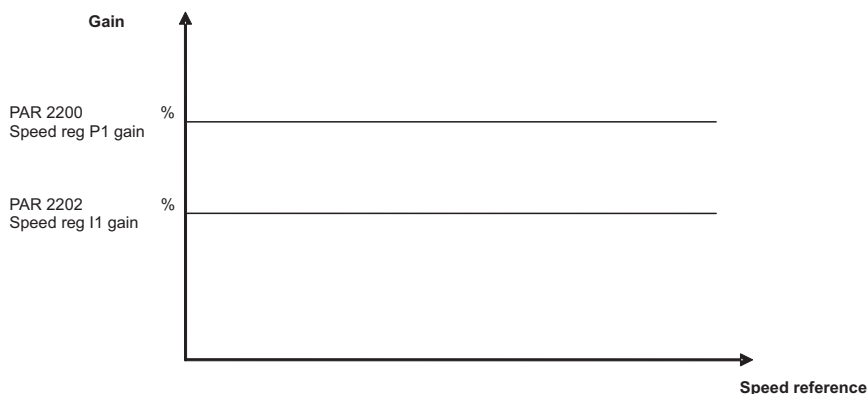

- If set to 1 the profile used is that shown in the figure below:

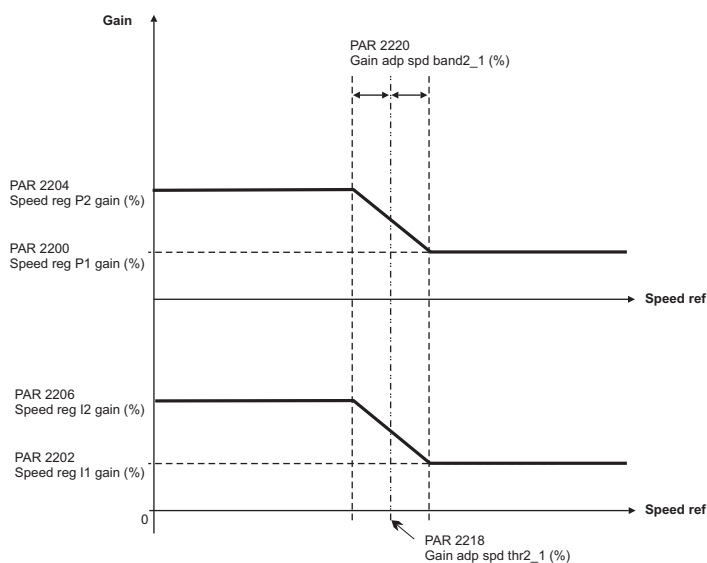

- If set to 2 the profile used is that shown in the figure below:

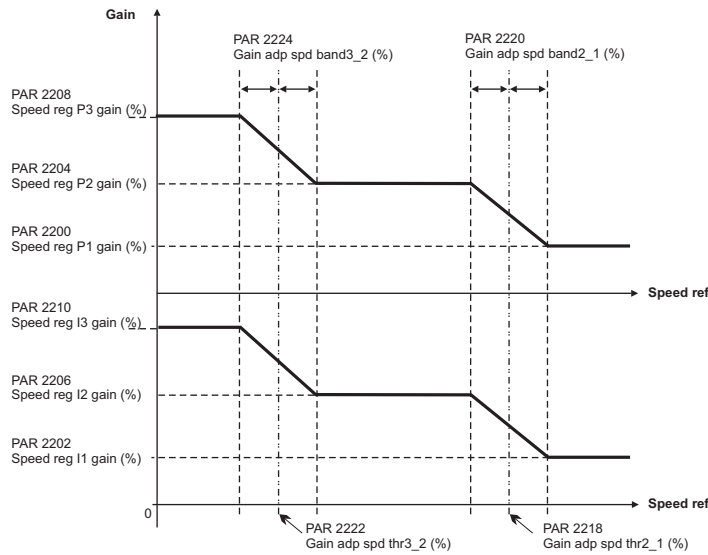

- If set to 3 the profile used is that shown in the figure below:

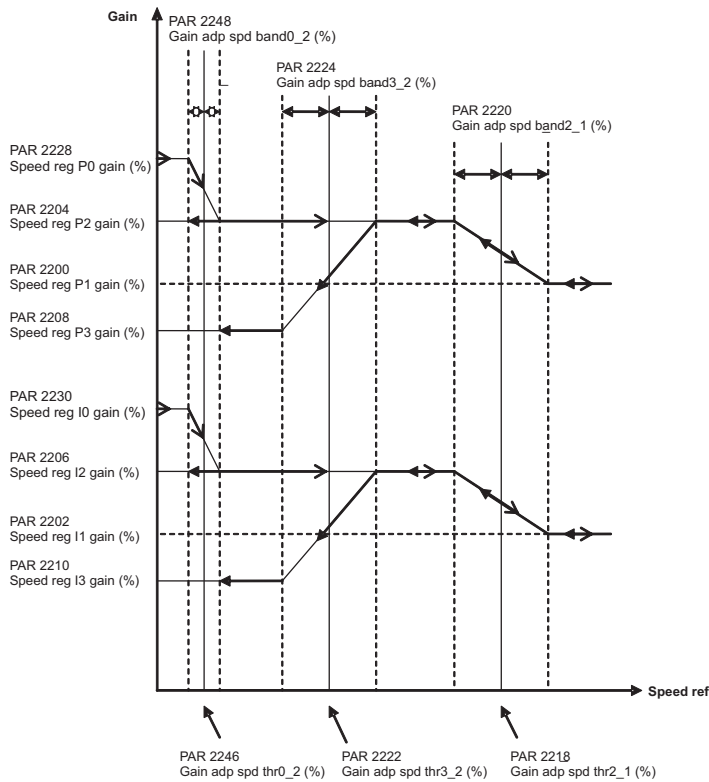

Menu	PAR	Description	UM	Type	FB BIT	Def	Min	Max	Acc	Mod
16.16	2232	Spd reg P gain Inuse	perc	INT16	16/32BIT	100	0	1000	ER	F__

The current proportional coefficient of the speed regulator is displayed as a percentage.

Menu	PAR	Description	UM	Type	FB BIT	Def	Min	Max	Acc	Mod
16.17	2234	Spd reg I gain Inuse	perc	INT16	16/32BIT	100	0	1000	ER	F__

The current integral coefficient of the speed regulator is displayed as a percentage.

Menu	PAR	Description	UM	Type	FB BIT	Def	Min	Max	Acc	Mod
16.18	2236	Speed reg P gain	N/rpm	FLOAT		CALCF	0.0	500.0	ERWS	F__

Setting of the proportional coefficient of the speed regulator.

Menu	PAR	Description	UM	Type	FB BIT	Def	Min	Max	Acc	Mod
16.19	2238	Speed reg I time	ms	FLOAT		CALCF	1.0	5000.0	ERWS	F__
<p>Setting of the integral coefficient of the speed regulator. Reducing the integral time value increases the integral action of the regulator.</p>										

Menu	PAR	Description	UM	Type	FB BIT	Def	Min	Max	Acc	Mod
16.20	2240	Inertia	kgm2	FLOAT		SIZE	0.001	100.0	RWZS	F__
<p>Setting of total inertia of the application with reference to the motor shaft. When this parameter is modified, all speed regulator gains are initialised according to the value specified by parameter PAR 2242. An increase in the dynamic response of the speed regulator to a variation in the reference, can be modified by changing the current value during the acceleration/ deceleration phase, to counter the applied machine inertia.</p>										

Menu	PAR	Description	UM	Type	FB BIT	Def	Min	Max	Acc	Mod
16.21	2242	Bandwidth	rad/s	FLOAT		SIZE	1.0	500.0	RWZS	F__
<p>Setting of the bandwidth. Increasing the setting of this parameter increases the dynamic response and makes the system more rigid.</p>										

17 - REGULATOR PARAM

Menu	PAR	Description	UM	Type	FB BIT	Def	Min	Max	Acc	Mod
17.1	2250	Current reg P gain	V/A	FLOAT		CALCF	0.0	0.0	ERWS	F__

Setting of the proportional coefficient of the current regulator.

Menu	PAR	Description	UM	Type	FB BIT	Def	Min	Max	Acc	Mod
17.2	2252	Current reg I time	ms	FLOAT		CALCF	0.01	10000.0	ERWS	F__

Setting of the integral coefficient of the current regulator.

Menu	PAR	Description	UM	Type	FB BIT	Def	Min	Max	Acc	Mod
17.3	2270	Voltage reg P gain	Wb/V	FLOAT		CALCF	0.0	0.0	ERWS	F__

Setting of the proportional coefficient of the voltage regulator.

Menu	PAR	Description	UM	Type	FB BIT	Def	Min	Max	Acc	Mod
17.4	2272	Voltage reg I time	s	FLOAT		CALCF	0.1	100.0	ERWS	F__

Setting of the integral coefficient of the voltage regulator.

Menu	PAR	Description	UM	Type	FB BIT	Def	Min	Max	Acc	Mod
17.5	2280	Dead time limit	V	FLOAT		SIZE	0.0	50.0	ERWS	F__

Setting of the dead time voltage compensation value.
The dead time compensation function (**Dead time compensation**), compensates the distortion of output voltage caused by the voltage drop on the IGBT devices and their switching characteristics.
Distortion of output voltage could cause irregular motor rotation.

Menu	PAR	Description	UM	Type	FB BIT	Def	Min	Max	Acc	Mod
17.6	2282	Dead time slope	V/A	FLOAT		SIZE	0.0	200.0	ERWS	F__

Setting of the dead time compensation slope value.

Menu	PAR	Description	UM	Type	FB BIT	Def	Min	Max	Acc	Mod
17.7	2290	Voltage base	V	FLOAT		CALCF	50.0	690.0	ERWS	F__

Setting of the basic voltage of the motor. This parameter is calculated automatically by the self-tuning procedure.

Menu	PAR	Description	UM	Type	FB BIT	Def	Min	Max	Acc	Mod
17.8	2292	Voltage margin	perc	FLOAT		5.0	0.0	10.0	ERWS	F__

Setting of the voltage regulation margin according to the available voltage. In case of a Voltage base setting close to or equal to the actual mains value, **Voltage margin** represents the margin allowable by the voltage regulation to perform rapid current variations when load steps are suddenly applied.
A value of 5% allows a very fast response to load steps but with a loss of output voltage and thus power output (reduced power output).
The minimum value (1%) allows a maximum output voltage (around 98%) of the mains voltage to be achieved but with loss of quality of the dynamic response.

Menu	PAR	Description	UM	Type	FB BIT	Def	Min	Max	Acc	Mod
17.9	132	Magnet current lim	A	FLOAT		0.0	0.0	CALCF	ERWZS	F__

Setting of the magnetisation current when running at speeds of more than the rated motor speed.

18 - TORQUE CONFIG

Menu	PAR	Description	UM	Type	FB BIT	Def	Min	Max	Acc	Mod
18.1	2350	Torque curr lim Pos	A	FLOAT	16/32BIT	CALCF	0.0	CALCF	ERWS	F__

Setting of the active torque limit of the drive for the positive current direction (clockwise rotation and anti-clockwise braking).

Menu	PAR	Description	UM	Type	FB BIT	Def	Min	Max	Acc	Mod
18.2	2352	Torque curr lim Neg	A	FLOAT	16/32BIT	CALCF	0.0	CALCF	ERWS	F__

Setting of the active torque limit of the drive for the negative current direction (anti-clockwise rotation and clockwise braking).

Menu	PAR	Description	UM	Type	FB BIT	Def	Min	Max	Acc	Mod
18.3	2354	Torque curr lim sel		ENUM		Sorg limcoppia	0	3	ERWZ	F__

Setting of the type of behaviour of the drive in the current limit condition.

- 0 Off
- 1 T clim +/-
- 2 T clim mot/gen
- 3 T limit src

If set to **0** no specific type of current limitation is set.

If set to **1** the active positive torque limit is **Torque curr lim Pos** and the active negative torque limit is **Torque curr lim Neg**.

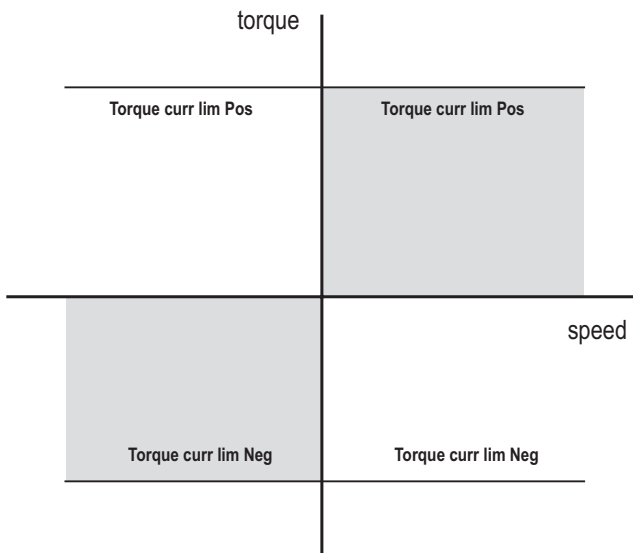

Torque limits with Torque curr lim Sel = 1

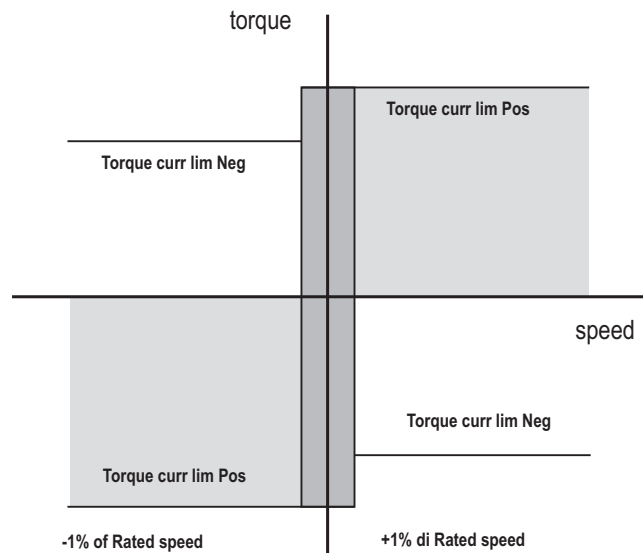

Torque limits with Torque curr lim sel = 2

If set to **2** three conditions are possible:

- 1 – If the motor speed is $> +1\%$ of **Rated speed** the active positive torque limit is **Torque curr lim Pos** and the active negative torque limit is **Torque curr lim Neg**.
- 2 – If the motor speed is $< -1\%$ of **Rated speed** the active positive torque limit is **Torque curr lim Neg** and the active negative torque limit is **Torque curr lim Pos**.
- 4 – If -1% of Motor non speed $<$ motor speed $<$ $+1\%$ of **Rated speed** the active positive torque limit is **Torque curr lim Pos** and the active negative torque limit is **Torque curr lim Neg**

If set to **3** the torque limits are symmetrical. The torque reference is the value of **Torque curr lim Pos**. This mode is not managed with SSC control mode.

Menu	PAR	Description	UM	Type	FB BIT	Def	Min	Max	Acc	Mod
18.4	2358	Torque limit src		LINK	16/32BIT	3726	0	16384	ERWZ	F__

Selection of the origin (source) of the signal to be used for the torque current limit. The signals that can be associated with the function are listed in the "**L_LIM**" selection list.

Menu	PAR	Description	UM	Type	FB BIT	Def	Min	Max	Acc	Mod
18.5	2360	Torque climPos Inuse	A	FLOAT	16/32BIT	0.0	0.0	0.0	ER	F__

The positive torque limit value currently being used is displayed.

Menu	PAR	Description	UM	Type	FB BIT	Def	Min	Max	Acc	Mod
18.6	2362	Torque climNeg Inuse	A	FLOAT	16/32BIT	0.0	0.0	0.0	ER	F__
The negative torque limit value currently being used is displayed.										
Menu	PAR	Description	UM	Type	FB BIT	Def	Min	Max	Acc	Mod
18.7	2380	Dig torque ref 1	perc	FLOAT	16/32BIT	0.0	-300.0	300.0	ERW	F__
Setting of a digital torque reference. The current reference value is proportional to the active motor current and determines the torque value. The sign determines the torque direction.										
Menu	PAR	Description	UM	Type	FB BIT	Def	Min	Max	Acc	Mod
18.8	2382	Torque ref 1 src		LINK	16/32BIT	3104	0	16384	ERWZ	F__
Selection of the origin (source) of the signal to be used for the torque reference. The signals that can be associated with the function are listed in the " L_VREF " selection list.										
Menu	PAR	Description	UM	Type	FB BIT	Def	Min	Max	Acc	Mod
18.9	2384	Torque ref filter	ms	FLOAT		1.0	0.1	10.0	ERW	F__
Setting of a filter on the torque reference.										
Menu	PAR	Description	UM	Type	FB BIT	Def	Min	Max	Acc	Mod
18.10	2386	Torque ref	perc	FLOAT	16/32BIT	0.0	0.0	0.0	ER	F__
The value of the torque reference is displayed.										

19 - FUNCTIONS

19.1 - FUNCTIONS/INERTIA COMP

An increase in the dynamic response of the speed regulator to a variation in the reference, can be modified by changing the current value during the acceleration/deceleration phase, to counter the applied machine inertia.

These parameters are calculated by the speed loop autotuning procedure but can also be set manually by the user.

Nota ! This menu is not displayed if the lift application is active.

Menu	PAR	Description	UM	Type	FB BIT	Def	Min	Max	Acc	Mod
19.1.1	3100	Inertia comp	kgm2	FLOAT		0.0	0.0	100.0	ERWS	F__
Total value of the inertia on the motor shaft in Kgm ² identified during the self-tuning procedure. If known, this value can also be set manually by the user.										

Menu	PAR	Description	UM	Type	FB BIT	Def	Min	Max	Acc	Mod
19.1.2	3102	Inertia comp filter	ms	UINT16		30	1	100	ERW	F__
Setting of a filter on the torque compensation. The filter reduces noise due to speed differentiation in the inertia block.										

Menu	PAR	Description	UM	Type	FB BIT	Def	Min	Max	Acc	Mod
19.1.3	3104	Inertia comp mon	perc	FLOAT	16/32BIT	0.0	0.0	0.0	ER	F__
The value of inertia compensation on the function block output is displayed.										

Menu	PAR	Description	UM	Type	FB BIT	Def	Min	Max	Acc	Mod
19.1.4	3108	Inertia comp mode		ENUM		Internal	0	1	ERWZ	F_S
0 Internal 1 External Inertia compensation mode.										

19.2 - FUNCTIONS/MOTOR OVERLOAD

The overload control function provides integrator logic to protect the motor against thermal overload. This protection presents the characteristic I²t behaviour and is an emulation of the thermal relay of the motor controlled by the ADL300 drive.

Menu	PAR	Description	UM	Type	FB BIT	Def	Min	Max	Acc	Mod
19.2.1	3200	Motor ovid enable		BIT		0	0	1	ERW	F__
Enabling of the motor overload control.										

Menu	PAR	Description	UM	Type	FB BIT	Def	Min	Max	Acc	Mod
19.2.2	3202	Motor ovid factor	perc	FLOAT		150.0	100.0	300.0	ERWS	F__
Setting of the motor overload value. Percentage value of the motor rated current (par. 2002 Rated current).										

Menu	PAR	Description	UM	Type	FB BIT	Def	Min	Max	Acc	Mod
19.2.3	3204	Motor ovid time	s	FLOAT		30.0	10.0	300.0	ERWS	F__
Setting of the motor overload duration in seconds. It represents the moment in which the protection ("Motor Overload") is enabled, if the motor current value is above the overload set in the Motor ovid factor parameter. This alarm can be assigned to a programmable digital output (Motor overload trip).										

The trip time depends on the motor current value and is as follows:

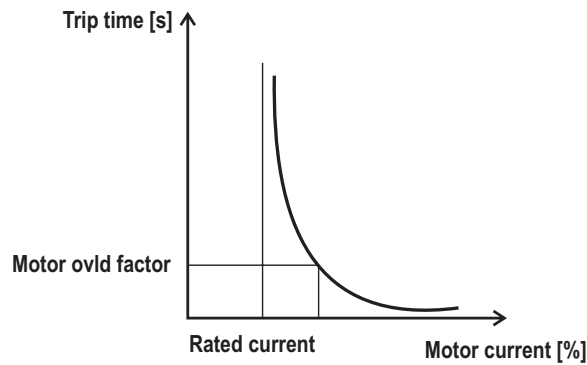

Menu	PAR	Description	UM	Type	FB BIT	Def	Min	Max	Acc	Mod
19.2.4	3206	Motor service factor	perc	FLOAT		100.0	25.0	200.0	ERWS	F__

Setting of the motor service factor. This is the difference between the peak current and rated current. It is used to calculate the thermal image of the motor.

Menu	PAR	Description	UM	Type	FB BIT	Def	Min	Max	Acc	Mod
19.2.5	3216	Motor fan type		ENUM		Servo fan	0	1	ERW	FVS

This parameter is used to set the type of motor cooling system.

- 0 Auto fan
- 1 Servo fan

Auto fan indicates the presence of a fan unit mounted on the motor shaft that therefore turns at a speed proportional to the motor speed. Cooling is not very effective at low motor speeds.

Servo fan indicates the presence of an independent fan unit that therefore always runs at the rated speed. It ensures optimum cooling efficiency at all motor speeds.

When the current motor speed is below (PAR 2004 **Rated speed** / 2) and PAR 3216 **Motor fan type** = Auto fan; , the MOTOR OVERLOAD protection intervention time must be reduced as cooling is insufficient.

At below (PAR 2004 **Rated speed** / 2) the protection intervention time is reduced by reducing the direct current of the MOTOR OVERLOAD function.

When the motor speed is equal to (PAR 2004 **Rated speed** / 2) the direct current of the MOTOR OVERLOAD function is equal to PAR 2002 **Rated current** * PAR 3206 **Motor service factor** , whereas below that limit it is modified following a linear pattern until PAR 2002 **Rated current** * 3206 **Motor service factor** * PAR 3218 **Motor derat factor** when the motor speed reaches zero.

The overload current of the MOTOR OVERLOAD function is obtained by PAR 2002 **Rated current** * 3206 **Motor service factor** * PAR 3202 **Motor ovid factor** and is the maximum current that can circulate in the motor. If the MOTOR OVERLOAD function is enabled the drive automatically sets the torque current limit so that I_{out max.} does not exceed this value.

With the MOTOR OVERLOAD function a current equal to the Overload level is supplied to the motor for the maximum time set in PAR 3204 **Motor ovid time**. The slower the motor speed, the shorter the time allowed (see figure at beginning of chapter).

After the set time, the MOTOR OVERLOAD function automatically sets the torque current limit so that I_{out max.} does not exceed the direct current of the MOTOR OVERLOAD function.

When the motor current speed exceeds (PAR 2004 **Rated speed** / 2) and PAR 3216 **Motor fan type** = Auto fan, the direct current is not reduced as cooling is sufficient.

When PAR 3216 **Motor fan type** = Servo fan, the direct current is not reduced as cooling is sufficient.

Menu	PAR	Description	UM	Type	FB BIT	Def	Min	Max	Acc	Mod
19.2.6	3218	Motor derat factor	perc	FLOAT		50.0	0.0	100.0	ERWS	FVS

This parameter is used to set the derating factor. The value is expressed as a percentage of PAR 2002 **Rated current** * PAR 3206 **Motor service factor**.

When the current motor speed is below (PAR 2004 **Rated speed** / 2) and PAR 3216 **Motor fan type** = Auto fan, the protection intervention time must be reduced as cooling is insufficient.

At below (PAR 2004 **Rated speed** / 2) the protection intervention time is reduced by reducing the direct current of the MOTOR OVERLOAD function.

When the motor speed is equal to (PAR 2004 **Rated speed** / 2) the direct current of the MOTOR OVERLOAD function

is equal to PAR 2002 **Rated current** * PAR 3206 **Motor service factor**, whereas below that limit it is modified following a linear pattern until PAR 2002 **Rated current** * PAR 3206 **Motor service factor** * PAR 3218 **Motor derat factor** when the motor speed reaches zero.

The overload current of the MOTOR OVERLOAD function is obtained by PAR 2002 **Rated current** * PAR 3206 **Motor service factor** * PAR 3202 **Motor ovoid factor** and is the maximum current that can circulate in the motor. If the MOTOR OVERLOAD function is enabled the drive automatically sets the torque current limit so that I_{out max.} does not exceed this value.

With the MOTOR OVERLOAD function a current equal to the Overload level is supplied to the motor for the maximum time set in PAR 3204 **Motor ovoid time**, The slower the motor speed, the shorter the time allowed (see graphs).

After the set time, the MOTOR OVERLOAD function automatically sets the torque current limit so that I_{out max.} does not exceed the direct current of the MOTOR OVERLOAD function.

When the motor current speed exceeds (PAR 2004 **Rated speed** / 2) and PAR 3216 **Motor fan type** = Auto fan, the direct current is not reduced as cooling is sufficient.

When PAR 3216 **Motor fan type** = Servo fan, the direct current is not reduced as cooling is sufficient.

If the value of parameter 3202 **Motor ovoid factor** is 100 % the overload current of the Motor Overload function is equal to the continuous current of the Motor Overload function. In this case the drive behaves as if the overload cycle has been executed and so sets the torque current limit so that I_{out max.} is not more than the continuous current, i.e. **Rated current** (PAR 2002) * **Motor service factor** (PAR 3206) * **Motor derat factor** (PAR 3218).

We recommend setting parameter 3218 **Motor derat factor** to a value so that **Rated current** (PAR 2002) * **Motor service factor** (PAR 3206) * **Motor derat factor** (PAR 3218) produces a result that is more than the motor magnetisation current.

19.3 - FUNCTIONS/BRES OVERLOAD

Menu	PAR	Description	UM	Type	FB BIT	Def	Min	Max	Acc	Mod
19.3.1	3250	Bres control		BIT		1	0	1	ERWZ	F__

Enabling of the external braking resistance and relative overload control.

Menu	PAR	Description	UM	Type	FB BIT	Def	Min	Max	Acc	Mod
19.3.2	3252	Bres value	ohm	FLOAT		SIZE	7.0	1000.0	ERWS	F__

Setting of the ohm value of the external braking resistor

Menu	PAR	Description	UM	Type	FB BIT	Def	Min	Max	Acc	Mod
19.3.3	3254	Bres cont power	kW	FLOAT		SIZE	0.1	100.0	ERWS	F__

Setting of the power that can be continuously dissipated by the external braking resistor.

Menu	PAR	Description	UM	Type	FB BIT	Def	Min	Max	Acc	Mod
19.3.4	3256	Bres overload factor		FLOAT		SIZE	1.5	10.0	ERWS	F__

Setting of the external resistor overload factor.

Menu	PAR	Description	UM	Type	FB BIT	Def	Min	Max	Acc	Mod
19.3.5	3258	Bres overload time	s	FLOAT		SIZE	0.5	50.0	ERWS	F__

Setting of the intervention time of the external braking resistor overload.

19.4 - FUNCTIONS/DOUBLE PAR SET

Two independent sets of parameters can be stored in the ADL300 drive. These can be selected via the keypad or by using an external command.

This makes it possible to change all the drive parameters quickly and automatically according to the various operating requirements. For example, two motors with different characteristics can be controlled alternately.

Lift application parameters are not included in the two sets of parameters. This makes it possible to switch between all drive parameters in two separate groups, while having a single set of parameters for the application.

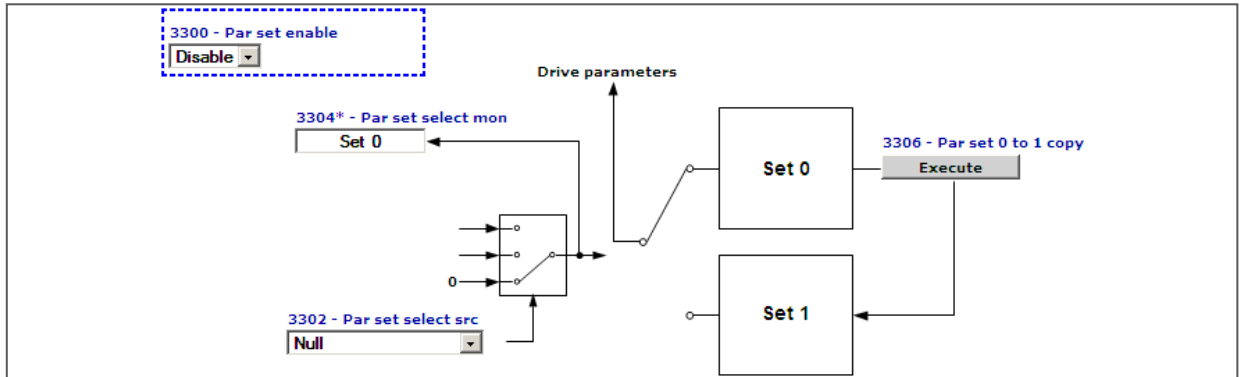

Menu	PAR	Description	UM	Type	FB BIT	Def	Min	Max	Acc	Mod
19.4.1	3300	Par set enable		ENUM		Disable	0	1	ERW	F__

Enabling of management of two parameter sets

- 0 Disable
- 1 Enable

When set to 0 only one parameter set is managed (the one used as the default set).

If set to 1 two separate parameter sets can be configured. These can be selected using a command signal on a digital input of the terminal strip.

Menu	PAR	Description	UM	Type	FB BIT	Def	Min	Max	Acc	Mod
19.4.2	3302	Par set select src		LINK	16BIT	6000	0	16384	ERWZ	F__

Selection of the origin (source) of the signal to be used to select the parameter set to be used. The terminal or digital command that can be associated with this function can be selected from among those available in the "L_DIGSEL2" selection list.

Menu	PAR	Description	UM	Type	FB BIT	Def	Min	Max	Acc	Mod
19.4.3	3304	Par set select mon		ENUM	16BIT	Set 0	0	0	ER	F__

The parameter set currently in use is displayed.

- 0 Set 0
- 1 Set 1

Menu	PAR	Description	UM	Type	FB BIT	Def	Min	Max	Acc	Mod
19.4.4	3306	Par set 0 to 1 copy			BIT	0	0	1	ERWZ	F__

Procedures for setting up and managing the double parameter set

Creating the second set:

This function copies parameter set 0 onto set 1. Before enabling management of the double parameter set, the first set should be programmed with the correct values.

When the first set is ready, the second can be activated as follows:

- 1 Activate management of the double parameter set by enabling parameter **3300 Par set enable**.
- 2 Copy set 0 onto set 1 using command **3306 Par set 0 to 1 copy**.
This creates an initial parameter base in set 1 to which changes can be made.
Save the parameters.
- 3 Activate set 1 using parameter **3302 Par set select src**.
To select set 1 manually, set this parameter to "One".
Otherwise select the desired source.
- 4 Modify the parameters in set 1 as necessary.
- 5 Save the parameters.

You can change the set being used by changing the source selected in parameter **3302 Par set select src**. This can only be changed with the drive disabled.

When the double parameter set is active, the number of the set being used is shown next to the number of each parameter on the keypad.

Modifying and saving parameters:

When the double parameter set is active, any parameters that need to be the same in the two sets must be modified in each set separately.

Parameters are only saved in the set that is active at the time. To save both sets, you must first save one and then select and save the other.

Note!

Any changes to the parameters regarding the "parameter sets", performed when enabled, will be lost at the next switching unless a Par set 0 to 1 copy command is sent.

To save data permanently (even when the drive is switched off), send the Save parameters command (DRIVE CONFIG menu).

19.5 - FUNCTIONS/COMPARE

This function allows the comparison among two signals or values.

Menu	PAR	Description	UM	Type	FB BIT	Def	Min	Max	Acc	Mod
19.5.1	3650	Dig compare input 1	perc	FLOAT	32BIT	0.0	-100.0	100.0	ERW	F__

Setting of the digital value of the first element of comparison.

Menu	PAR	Description	UM	Type	FB BIT	Def	Min	Max	Acc	Mod
19.5.2	3652	Dig compare input 2	perc	FLOAT	32BIT	0.0	-100.0	100.0	ERW	F__

Setting of the digital value of the second element of comparison.

Menu	PAR	Description	UM	Type	FB BIT	Def	Min	Max	Acc	Mod
19.5.3	3660	Compare input 1 src		LINK	32BIT	3650	0	16384	ERW	F__

Selection of the origin (source) of the signal to be used as the first term of comparison. The values that can be selected in the compare function are listed in the “**L_CMP**” selection list.

Menu	PAR	Description	UM	Type	FB BIT	Def	Min	Max	Acc	Mod
19.5.4	3662	Compare input 2 src		LINK	32BIT	3652	0	16384	ERW	F__

Selection of the origin (source) of the signal to be used as the second term of comparison. The values that can be selected in the compare function are listed in the “**L_CMP**” selection list.

Menu	PAR	Description	UM	Type	FB BIT	Def	Min	Max	Acc	Mod
19.5.5	3670	Compare function		ENUM		Nessuna	0	8	ERW	F__

Setting of the compare function between **Compare input 2** and **Compare input 1** to enable **Cmp output**.

- 0 None
- 1 Inp1=Inp2
- 2 Inp1!=Inp2
- 3 Inp1<Inp2
- 4 Inp1>Inp2
- 5 |Inp1|=|Inp2|
- 6 |Inp1|!=|Inp2|
- 7 |Inp1|<|Inp2|
- 8 |Inp1|>|Inp2|

If set to **0** the comparator is not enabled

If set to **1** the comparator output is enabled when the value of **Compare digital inp 1** is inside the window resulting from the value of **Compare digital inp 2** \pm the tolerance set via the **Comparator Window**.

If set to **2** the comparator output is enabled when the value of **Compare digital inp 1** is not inside the window resulting from the value of **Compare digital inp 2** \pm the tolerance set via the **Comparator Window**.

If set to **3** the comparator output is enabled when **Compare input 1** is less than **Compare input 2**.

If set to **4** the comparator output is enabled when **Compare input 1** is greater than **Compare input 2**.

If set to **5** the comparator output is enabled when the value of **Compare digital inp 1** is inside the window resulting from the absolute value of **Compare digital inp 2** \pm the tolerance set via the **Comparator Window**.

If set to **6** the comparator output is enabled when the absolute value of **Compare digital inp 1** is not inside the window resulting from the absolute value of **Compare digital inp 2** \pm the tolerance set via the **Comparator Window**.

If set to **7** the comparator output is enabled when the absolute value of **Compare digital inp 1** is less than the absolute value of **Compare digital inp 2**.

If set to **8** the comparator output is enabled when the absolute value of **Digital compar inp1** is more than the absolute value of **Digital compar in2**.

Menu	PAR	Description	UM	Type	FB BIT	Def	Min	Max	Acc	Mod
19.5.6	3672	Compare window	perc	FLOAT		0.0	0.0	100.0	ERW	F__

Setting of the tolerance window for comparing the **Compare input 1** and **Compare input 2** signals.

Menu	PAR	Description	UM	Type	FB BIT	Def	Min	Max	Acc	Mod
19.5.7	3674	Compare delay	s	FLOAT		0.0	0.0	30.0	ERW	F__

Setting of the delay for signalling the result of the comparison.

Menu	PAR	Description	UM	Type	FB BIT	Def	Min	Max	Acc	Mod
19.5.8	3676	Compare output		BIT	16BIT	0	0	1	ER	F__

The status of the comparator output is displayed:

0 The result of the set comparison is negative

1 The result of the set comparison is positive

19.6 - FUNCTIONS/PADS

The general variables are used to exchange data between the various components of a Bus system. They are similar to the variables of a PLC. Pads can be used, for example, to send information from a fieldbus to an optional card. All Pads can be read and written.

Menu	PAR	Description	UM	Type	FB BIT	Def	Min	Max	Acc	Mod
19.6.1	3700	Lift enable		INT32	32BIT	0	0	0	ERW	F__
19.6.2	3702	Run cont mon		INT32	32BIT	0	0	0	ERW	F__
19.6.3	3704	Up cont mon		INT32	32BIT	0	0	0	ERW	F__
19.6.4	3706	Down cont mon		INT32	32BIT	0	0	0	ERW	F__
19.6.5	3708	Brake cont mon		INT32	32BIT	0	0	0	ERW	F__
19.6.6	3710	Lift dc brake		INT32	32BIT	0	0	0	ERW	F__
19.6.7	3712	Brake 2 mon		INT32	32BIT	0	0	0	ERW	F__
19.6.8	3714	Door open mon		INT32	32BIT	0	0	0	ERW	F__
19.6.9	3716	Lift start		INT32	32BIT	0	0	0	ERW	F__
19.6.10	3718	Pad 10		INT32	32BIT	0	0	0	ERW	F__
19.6.11	3720	Lift status word		INT32	32BIT	0	0	0	ERW	F__
19.6.12	3722	Pad 12		INT32	32BIT	0	0	0	ERW	F__
19.6.13	3724	Pad 13		INT32	32BIT	0	0	0	ERW	F__
19.6.14	3726	Ramp down limit		INT32	32BIT	0	0	0	ERW	F__
19.6.15	3728	PAD 15		INT32	32BIT	0	0	0	ERW	F__
19.6.16	3730	Lift wdec input		INT32	32BIT	0	0	0	ERW	F__

Setting of general, 32 Bit variables. PAD parameters can be used as supporting parameters to send values written by the fieldbus, serial line, etc. to analog or digital outputs.

19.7 - FUNCTIONS/DIRECTION COUNT

The “Change ride direction count” function monitors usage of the ropes or belts, signals when maintenance/replacement is needed, and locks the lift if limits of usage are reached. This function is reserved to lift maintenance personnel and is protected by a specific password.

Rope usage is typically measured in “changes of direction”: the maximum number is specified on a certificate supplied by the rope manufacturer.

A specific counter keeps count of direction changes and can be reset when the ropes are replaced.

The following signals, inserted in the L_DIGSEL1 selection list, can be brought to a digital output: PAR 3420 **Ropes change req mon**, PAR 3422 **Direction change mon** and PAR 3424 **Dir change cnt zero**.

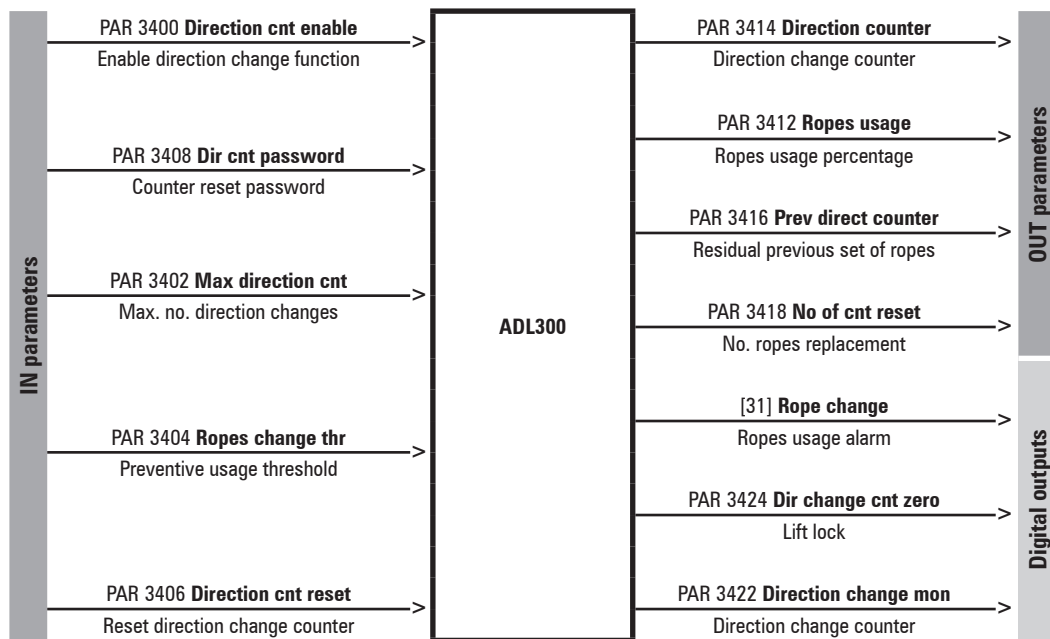

Importante!

Firmware update

To keep them from being overwritten when using Gefran eXpress, these parameters are not updated with the **Write all target parameters** operation.

Replacing the drive

If the drive is replaced, you can save the configuration of the “Direction change count” function on the keypad (PAR 3434 **Save to keypad**) and load it on the new drive (PAR 3436 **Load from keypad**).

Password

All of the parameters of this function, reserved to lift maintenance personnel, are protected by a specific password. The password is managed via parameters PAR 3408 **Dir cnt password** and PAR 3410 **Dir cnt new password**.

Menu	PAR	Description	UM	Type	FB BIT	Def	Min	Max	Acc	Mod
19.7.1	3400	Direction cnt enable		ENUM		Disable	0	1	ERW	FVS
		0 Disable								
		1 Enable								
		Enables the “Direction change count” function.								

Menu	PAR	Description	UM	Type	FB BIT	Def	Min	Max	Acc	Mod
19.7.2	3402	Max direction cnt		UINT32		0	0	2147483647	ERW	FVS
		Sets the maximum allowed number of direction changes.								

Menu	PAR	Description	UM	Type	FB BIT	Def	Min	Max	Acc	Mod
19.7.3	3404	Ropes change thr	perc	UINT16		0	0	100	ERW	FVS

Sets a usage threshold beyond which the “Rope change” alarm is signalled to indicate that the ropes have to be replaced. When parameter 3412 **Ropes usage** exceeds this threshold, the drive keeps running but the alarm stays on to remind the operator to replace the ropes.

Menu	PAR	Description	UM	Type	FB BIT	Def	Min	Max	Acc	Mod
19.7.4	3406	Direction cnt reset		ENUM		Disable	0	1	ERW	FVS
		0		Disable						
		1		Enable						

Let you run a reset to return the direction change counter to the initial value of parameter 3402 **Max direction cnt** (value set by rope manufacturer).

This operation is password-protected and must be run when the ropes are changed.

Executing this command causes the following:

1. the value of counter 3414 **Direction counter** is copied to parameter 3416 **Prev direct counter**,
2. the value of parameter 3414 **No of cnt reset** is incremented,
3. counter 3414 **Direction counter** is reset to value 3402 **Max direction cnt** and consequently parameter 3412 **Ropes usage** is reset to 0.

Menu	PAR	Description	UM	Type	FB BIT	Def	Min	Max	Acc	Mod
19.7.5	3408	Dir cnt password		UINT16		0	0	9999	ERW	FVS

This parameter is used to enter the password (max 4 numbers) to protect the “Direction change count” menu. The password is displayed only when it is entered; when not in this mode the display shows 0.

When the password has been entered, you can change it by entering a new one in PAR 3410 **Dir cnt new password**..

.....

The password is not reset when reloading default parameters and is also maintained when updating firmware.

Attention: if you forget the password you have to contact Gefran Technical Service.

.....

Menu	PAR	Description	UM	Type	FB BIT	Def	Min	Max	Acc	Mod
19.7.6	3410	Dir cnt new password		UINT16		0	0	9999	ERW	FVS

This parameter lets you change the password to replace the one entered in par 3408 **Dir cnt password**.

A combination of a maximum of 4 numbers is allowed. To access this parameter, you have to enable the menu by entering the old password in PAR 3408.

The password must be entered twice to be enabled.

Menu	PAR	Description	UM	Type	FB BIT	Def	Min	Max	Acc	Mod
19.7.7	3412	Ropes usage	perc	UINT16	16BIT	0	0	0	ER	FVS

Displays the ropes usage counter (as percentage) of parameter 3402 **Max direction cnt**.

When PAR 3412 = 100% (corresponds to PAR 3414 = 0), the ropes have reached their useful life and must be replaced: the drive finishes the current travel and then locks.

By switching the drive off and back on you can run a single travel to bring the car to a better position for the procedure.

To eliminate the lock condition, reset the direction change counter.

Menu	PAR	Description	UM	Type	FB BIT	Def	Min	Max	Acc	Mod
19.7.8	3414	Direction counter		UINT32	32BIT	0	0	0	ER	FVS

Displays the countdown of direction changes remaining until useful life of the ropes is reached.

When PAR 3414 = “0” the ropes must be replaced (corresponds to PAR 3412 = 100%): the drive finishes the current travel and then locks.

By switching the drive off and back on you can run a single travel to bring the car to a better position for the procedure.

To eliminate the lock condition, reset the direction change counter (see PAR 3406 **Direction cnt reset**).

Menu	PAR	Description	UM	Type	FB BIT	Def	Min	Max	Acc	Mod
19.7.9	3416	Prev direct counter		UINT32	32BIT	0	0	0	ER	FVS

Displays the number of direction changes remaining on the previous set of ropes (value of PAR 3414 **Direction counter** is



Importante!

copied before reset). This number will remain fixed until the next replacement of the ropes.

Menu	PAR	Description	UM	Type	FB BIT	Def	Min	Max	Acc	Mod
19.7.10	3418	No of cnt reset		UINT3232BIT		0	0	0	ER	FVS
Displays the number of rope changes made.										

Menu	PAR	Description	UM	Type	FB BIT	Def	Min	Max	Acc	Mod
19.7.11	3420	Ropes change req mon		BIT	16BIT	0	0	1	ER	FVS
Activates when the percentage of rope usage (set in PAR 3412 Ropes usage) exceeds the set threshold (PAR 3404 Ropes change thr).										
This signal is inserted in the L_DIGSEL1 selection list and can be brought to a digital output.										

Menu	PAR	Description	UM	Type	FB BIT	Def	Min	Max	Acc	Mod
19.7.12	3434	Save to keypad		BIT		0	0	1	ERWZ	FVS
Lets you save the configuration of the "Direction change count" function on the keypad.										
The set of parameters is saved in a dedicated area on the keypad, separate from that of the other parameters (PAR 590 Save par to keypad).										

Menu	PAR	Description	UM	Type	FB BIT	Def	Min	Max	Acc	Mod
19.7.13	3436	Load from keypad		BIT		0	0	1	ERWZ	FVS
Lets you load the configuration of the "Direction change count" function saved on the keypad with PAR 3434 Save to keypad on the new drive.										

20 - COMMUNICATION

20.1 - COMMUNICATION/RS232

The ADL300 drive is provided with a standard port (9 pole sub-D connector: XS) for connecting the RS232 serial line used for drive-PC point-to-point communication (via the GF-eXpress configuration software).

Menu	PAR	Description	UM	Type	FB BIT	Def	Min	Max	Acc	Mod
20.1.1	3800	Drive address		UINT16		1	1	255	ERW	F__

Setting of the address to which the drive responds when connected to the RS232 serial line.

Menu	PAR	Description	UM	Type	FB BIT	Def	Min	Max	Acc	Mod
20.1.2	3802	Serial baudrate		ENUM		38400	0	2	ERW	F__

Setting of the RS232 serial communication speed (Baud Rate).

- 0 9600
- 1 19200
- 2 38400

Menu	PAR	Description	UM	Type	FB BIT	Def	Min	Max	Acc	Mod
20.1.3	3810	Serial parameter		ENUM		None,8,1	0	3	ERW	F__

Setting of the format of the RS232 serial line.

- 0 None,8,1
- 1 None,8,2
- 2 Even,8,1
- 3 Odd,8,1

Menu	PAR	Description	UM	Type	FB BIT	Def	Min	Max	Acc	Mod
20.1.4	3804	Serial protocol		ENUM		Modbus	0	1	ERW	F__

Setting of the serial communication protocol:

- 0 Modbus
- 1 Jbus

Setting to 0 selects the Modbus RTU (Remote Terminal Unit) serial communication protocol.

Setting to 1 selects the Jbus serial communication protocol. The Jbus protocol is functionally identical to the Modbus, except for the different numbering of addresses: in the Modbus these start from zero (0000 = 1st address) while in the JBUS they start from one (0001 = 1st address) and maintain this difference throughout numbering.

Menu	PAR	Description	UM	Type	FB BIT	Def	Min	Max	Acc	Mod
20.1.5	3806	Serial delay	ms	UINT16		0	0	1000	ERW	F__

Setting of the minimum delay between the drive receiving the last byte and starting its response. This delay avoids conflicts on the serial line when the RS232 interface that is used has not been pre-set for automatic Tx/Rx switching. The parameter only concerns the use of the standard RS232 serial line.

Example: if the delay in Tx/Rx switching on the master is a maximum of 20ms, the **Serial answer delay** parameter must be set to at least 20ms: 22ms

Menu	PAR	Description	UM	Type	FB BIT	Def	Min	Max	Acc	Mod
20.1.6	3808	Serial swap data		BIT		0	0	1	ERW	F__

This parameter enables the exchange of the reading of the High and Low parts of the words for FLOAT type parameters when using the Modbus protocol.

20.2 - COMMUNICATION/FIELDBUS CONFIG

Menu	PAR	Description	UM	Type	FB BIT	Def	Min	Max	Acc	Mod
20.2.1	4000	Fieldbus type		ENUM		Spento	0	2	ERW	F__

Setting of the type of fieldbus to be used.

- 0 Off
- 1 CANopen
- 10 DS417

If set to **0** no fieldbus is selected.

If set to **1** the CANopen fieldbus profile is selected.

If set to **10** the DS417 fieldbus is selected.

The CiA 417 is an MDPLC application. See the CiA 417 manual for configuration).

Menu	PAR	Description	UM	Type	FB BIT	Def	Min	Max	Acc	Mod
20.2.2	4004	Fieldbus baudrate		ENUM		500k	0	4	ERW	F__

Setting of the communication network speed (Baud Rate)

- 0 Auto
- 1 125k
- 2 250k
- 3 500k
- 4 1M

Menu	PAR	Description	UM	Type	FB BIT	Def	Min	Max	Acc	Mod
20.2.3	4006	Fieldbus address		INT16		2	0	255	ERW	F__

Setting of the node address of the drive when connected to the network.

Menu	PAR	Description	UM	Type	FB BIT	Def	Min	Max	Acc	Mod
20.2.4	4010	Fieldbus M->S enable		ENUM		Enable	0	1	ERWZ	F__

Setting of fieldbus data updating.

- 0 Disable
- 1 Enable

If set to **0**, the possibility of sending commands and references from the drive PLC via the fieldbus is disabled.

If set to **1** the possibility of sending commands and references from the drive PLC via the fieldbus is enabled.

Menu	PAR	Description	UM	Type	FB BIT	Def	Min	Max	Acc	Mod
20.2.5	4012	Fieldbus alarm mode		INT32		0	0	1	ERWZ	F__

Setting of the Opt Bus Fault alarm generation mode.

- 0 Disable
- 1 Enable

If set to 0 the alarm is only generated if the communication with the fieldbus is lost with the drive enabled..

If set to 1 the alarm is generated when the communication with the fieldbus is lost even if the drive is disabled. .

Menu	PAR	Description	UM	Type	FB BIT	Def	Min	Max	Acc	Mod
20.2.6	4014	Fieldbus state		ENUM		Arresto	0	2	ER	F__

The logic status of the fieldbus connection is displayed. The value depends on the type of bus that is used.

- 0 Stop
- 1 Pre operational
- 2 Operational

20.3 - COMMUNICATION/FIELDBUS M2S

Menu	PAR	Description	UM	Type	FB BIT	Def	Min	Max	Acc	Mod
20.3.1	4020	Fieldbus M->S1 ipa		FBM2SIPA		0	0	20000	ERW	F__
20.3.5	4030	Fieldbus M->S2 ipa		FBM2SIPA		0	0	20000	ERW	F__
20.3.9	4040	Fieldbus M->S3 ipa		FBM2SIPA		0	0	20000	ERW	F__
20.3.13	4050	Fieldbus M->S4 ipa		FBM2SIPA		0	0	20000	ERW	F__
20.3.17	4060	Fieldbus M->S5 ipa		FBM2SIPA		0	0	20000	ERW	F__
20.3.21	4070	Fieldbus M->S6 ipa		FBM2SIPA		0	0	20000	ERW	F__
20.3.25	4080	Fieldbus M->S7 ipa		FBM2SIPA		0	0	20000	ERW	F__
20.3.29	4090	Fieldbus M->S8 ipa		FBM2SIPA		0	0	20000	ERW	F__
20.3.33	4100	Fieldbus M->S9 ipa		FBM2SIPA		0	0	20000	ERW	F__
20.3.37	4110	Fieldbus M->S10 ipa		FBM2SIPA		0	0	20000	ERW	F__
20.3.41	4120	Fieldbus M->S11 ipa		FBM2SIPA		0	0	20000	ERW	F__
20.3.45	4130	Fieldbus M->S12 ipa		FBM2SIPA		0	0	20000	ERW	F__
20.3.49	4140	Fieldbus M->S13 ipa		FBM2SIPA		0	0	20000	ERW	F__
20.3.53	4150	Fieldbus M->S14 ipa		FBM2SIPA		0	0	20000	ERW	F__
20.3.57	4160	Fieldbus M->S15 ipa		FBM2SIPA		0	0	20000	ERW	F__
20.3.61	4170	Fieldbus M->S16 ipa		FBM2SIPA		0	0	20000	ERW	F__

Setting of the parameter to associate with the bus channel. The default setting is 0, which corresponds to no signal connected. If the parameter to be connected is a **sorg** (source), the channel and parameter can also be associated by modifying the sorg parameter in its menu. When setting a parameter, the format is also automatically set in the sys parameter.

Menu	PAR	Description	UM	Type	FB BIT	Def	Min	Max	Acc	Mod
20.3.2	4022	Fieldbus M->S1 sys		ENUM		Not assigned	0	10	ERW	F__
20.3.6	4032	Fieldbus M->S2 sys		ENUM		Not assigned	0	10	ERW	F__
20.3.10	4042	Fieldbus M->S3 sys		ENUM		Not assigned	0	10	ERW	F__
20.3.14	4052	Fieldbus M->S4 sys		ENUM		Not assigned	0	10	ERW	F__
20.3.18	4062	Fieldbus M->S5 sys		ENUM		Not assigned	0	10	ERW	F__
20.3.22	4072	Fieldbus M->S6 sys		ENUM		Not assigned	0	10	ERW	F__
20.3.26	4082	Fieldbus M->S7 sys		ENUM		Not assigned	0	10	ERW	F__
20.3.30	4092	Fieldbus M->S8 sys		ENUM		Not assigned	0	10	ERW	F__
20.3.34	4102	Fieldbus M->S9 sys		ENUM		Not assigned	0	10	ERW	F__
20.3.38	4112	Fieldbus M->S10 sys		ENUM		Not assigned	0	10	ERW	F__
20.3.42	4122	Fieldbus M->S11 sys		ENUM		Not assigned	0	10	ERW	F__
20.3.46	4132	Fieldbus M->S12 sys		ENUM		Not assigned	0	10	ERW	F__
20.3.50	4142	Fieldbus M->S13 sys		ENUM		Not assigned	0	10	ERW	F__
20.3.54	4152	Fieldbus M->S14 sys		ENUM		Not assigned	0	10	ERW	F__
20.3.58	4162	Fieldbus M->S15 sys		ENUM		Not assigned	0	10	ERW	F__
20.3.62	4172	Fieldbus M->S16 sys		ENUM		Not assigned	0	10	ERW	F__

Setting of the format of the datum received on the channel. When the src parameter is programmed, the format is automatically programmed on the relative sys. If the src parameter is reset to null, the format does not change. The value of the format can be selected from the following list, according to the parameter selected as the source:

- 0 Not assigned
- 1 Count 16
- 2 Count 32
- 3 Fill 16
- 4 Fill 32
- 5 Mdplc 16
- 6 Mdplc 32
- 7 EU
- 8 Eu float
- 9 Par 16
- 10 Par 32

If set to **0** the channel is not assigned.

If set to **1** the datum is assigned a 16-bit count.

If set to **2** the datum is assigned a 32-bit count.

If set to **3** 16 bits on the channel are reserved for the datum, not used.
 If set to **4** 32 bits on the channel are reserved for the datum, not used.
 If set to **5** the datum is assigned a 16-bit count used by MDPLC.
 If set to **6** the datum is assigned a 32-bit count used by MDPLC.
 If set to **7** the datum is assigned engineering units on a 16-bit integer.
 If set to **8** the datum is assigned engineering units on a 32-bit integer.
 If set to **9**, the datum is assigned a 16-bit integer engineering unit format not in real time (5-10ms)
 If set to **10** the datum is assigned a 32-bit integer engineering unit format or float format if the associated parameter is a float-type parameter not in real time (5-10ms).

Note! If the sys parameter is **not assigned**, none of the subsequent fieldbus channels are read, even if programmed.

Menu	PAR	Description	UM	Type	FB BIT	Def	Min	Max	Acc	Mod
20.3.3	4024	Fieldbus M->S1 mon		INT32	32BIT	0	0	0	ER	F__
20.3.7	4034	Fieldbus M->S2 mon		INT32	32BIT	0	0	0	ER	F__
20.3.11	4044	Fieldbus M->S3 mon		INT32	32BIT	0	0	0	ER	F__
20.3.15	4054	Fieldbus M->S4 mon		INT32	32BIT	0	0	0	ER	F__
20.3.19	4064	Fieldbus M->S5 mon		INT32	32BIT	0	0	0	ER	F__
20.3.23	4074	Fieldbus M->S6 mon		INT32	32BIT	0	0	0	ER	F__
20.3.27	4084	Fieldbus M->S7 mon		INT32	32BIT	0	0	0	ER	F__
20.3.31	4094	Fieldbus M->S8 mon		INT32	32BIT	0	0	0	ER	F__
20.3.35	4104	Fieldbus M->S9 mon		INT32	32BIT	0	0	0	ER	F__
20.3.39	4114	Fieldbus M->S10 mon		INT32	32BIT	0	0	0	ER	F__
20.3.43	4124	Fieldbus M->S11 mon		INT32	32BIT	0	0	0	ER	F__
20.3.47	4134	Fieldbus M->S12 mon		INT32	32BIT	0	0	0	ER	F__
20.3.51	4144	Fieldbus M->S13 mon		INT32	32BIT	0	0	0	ER	F__
20.3.55	4154	Fieldbus M->S14 mon		INT32	32BIT	0	0	0	ER	F__
20.3.59	4164	Fieldbus M->S15 mon		INT32	32BIT	0	0	0	ER	F__
20.3.63	4174	Fieldbus M->S16 mon		INT32	32BIT	0	0	0	ER	F__

The value received from the bus is displayed. This parameter must be associated with the src parameter to enable the M->S channel.

The user may modify the M->S and by S->M sys parameters. The consistency of the sys with the parameter assigned to the channel is checked.

A Fieldbus M->S X Mon parameter can only be assigned to a single "src". If assigned to more than one src, an error signal is generated during fieldbus initialization.

Menu	PAR	Description	UM	Type	FB BIT	Def	Min	Max	Acc	Mod
20.3.4	4026	Fieldbus M->S1 div		FLOAT		1.0	1.0	1000.0	ERW	F__
20.3.8	4036	Fieldbus M->S2 div		FLOAT		1.0	1.0	1000.0	ERW	F__
20.3.12	4046	Fieldbus M->S3 div		FLOAT		1.0	1.0	1000.0	ERW	F__
20.3.16	4056	Fieldbus M->S4 div		FLOAT		1.0	1.0	1000.0	ERW	F__
20.3.20	4066	Fieldbus M->S5 div		FLOAT		1.0	1.0	1000.0	ERW	F__
20.3.24	4076	Fieldbus M->S6 div		FLOAT		1.0	1.0	1000.0	ERW	F__
20.3.28	4086	Fieldbus M->S7 div		FLOAT		1.0	1.0	1000.0	ERW	F__
20.3.32	4096	Fieldbus M->S8 div		FLOAT		1.0	1.0	1000.0	ERW	F__
20.3.36	4106	Fieldbus M->S9 div		FLOAT		1.0	1.0	1000.0	ERW	F__
20.3.40	4116	Fieldbus M->S10 div		FLOAT		1.0	1.0	1000.0	ERW	F__
20.3.44	4126	Fieldbus M->S11 div		FLOAT		1.0	1.0	1000.0	ERW	F__
20.3.48	4136	Fieldbus M->S12 div		FLOAT		1.0	1.0	1000.0	ERW	F__
20.3.52	4146	Fieldbus M->S13 div		FLOAT		1.0	1.0	1000.0	ERW	F__
20.3.56	4156	Fieldbus M->S14 div		FLOAT		1.0	1.0	1000.0	ERW	F__
20.3.60	4166	Fieldbus M->S15 div		FLOAT		1.0	1.0	1000.0	ERW	F__
20.3.64	4176	Fieldbus M->S16 div		FLOAT		1.0	1.0	1000.0	ERW	F__

The Div M->Sx fieldbus parameters can be used to increase the resolution of the datum sent on the bus to the drive in the corresponding channel in EU and EU_float exchange mode. The parameter value is used by the drive as the divider of the incoming datum, so that a number with decimal digits can be transferred.

Nota!

You must check the size in bits of the datum that is sent to make sure that the maximum value in bits fits in a 16-bit integer. For example, if specifying the divider as "Fieldbus M->Sn div" = 1000, the maximum value that can be used for the exchanged datum is 32.768 (32768/1000).

Example : **Div M->Sx fieldbus = 10, M->S1 fieldbus par = Ramp ref src 1, Sys M->S1 fieldbus = Eu.** If the PLC sends the decimal value 1000 on the first word the value of **ramp ref 1** on the drive is $1000/10 = 100$.

.....

20.4 - COMMUNICATION/FIELDBUS S2M

Menu	PAR	Description	UM	Type	FB BIT	Def	Min	Max	Acc	Mod
20.4.1	4180	Fieldbus S->M1 ipa		FBS2MIPA		0	0	20000	ERW	F__
20.4.5	4190	Fieldbus S->M2 ipa		FBS2MIPA		0	0	20000	ERW	F__
20.4.9	4200	Fieldbus S->M3 ipa		FBS2MIPA		0	0	20000	ERW	F__
20.4.13	4210	Fieldbus S->M4 ipa		FBS2MIPA		0	0	20000	ERW	F__
20.4.17	4220	Fieldbus S->M5 ipa		FBS2MIPA		0	0	20000	ERW	F__
20.4.21	4230	Fieldbus S->M6 ipa		FBS2MIPA		0	0	20000	ERW	F__
20.4.25	4240	Fieldbus S->M7 ipa		FBS2MIPA		0	0	20000	ERW	F__
20.4.29	4250	Fieldbus S->M8 ipa		FBS2MIPA		0	0	20000	ERW	F__
20.4.33	4260	Fieldbus S->M9 ipa		FBS2MIPA		0	0	20000	ERW	F__
20.4.37	4270	Fieldbus S->M10 ipa		FBS2MIPA		0	0	20000	ERW	F__
20.4.41	4280	Fieldbus S->M11 ipa		FBS2MIPA		0	0	20000	ERW	F__
20.4.45	4290	Fieldbus S->M12 ipa		FBS2MIPA		0	0	20000	ERW	F__
20.4.49	4300	Fieldbus S->M13 ipa		FBS2MIPA		0	0	20000	ERW	F__
20.4.53	4310	Fieldbus S->M14 ipa		FBS2MIPA		0	0	20000	ERW	F__
20.4.57	4320	Fieldbus S->M15 ipa		FBS2MIPA		0	0	20000	ERW	F__
20.4.61	4330	Fieldbus S->M16 ipa		FBS2MIPA		0	0	20000	ERW	F__

Setting of the parameter to associate with the bus channel. The default setting is 0, which corresponds to no signal connected. If the parameter to be connected is a sorg (source), the channel and parameter can also be associated by modifying the sorg parameter in its menu. When setting a parameter, the format is also automatically set in the sys parameter.

Menu	PAR	Description	UM	Type	FB BIT	Def	Min	Max	Acc	Mod
20.4.2	4182	Fieldbus S->M1 sys		ENUM		Not assigned	0	10	ERW	F__
20.4.6	4192	Fieldbus S->M2 sys		ENUM		Not assigned	0	10	ERW	F__
20.4.10	4202	Fieldbus S->M3 sys		ENUM		Not assigned	0	10	ERW	F__
20.4.14	4212	Fieldbus S->M4 sys		ENUM		Not assigned	0	10	ERW	F__
20.4.18	4222	Fieldbus S->M5 sys		ENUM		Not assigned	0	10	ERW	F__
20.4.22	4232	Fieldbus S->M6 sys		ENUM		Not assigned	0	10	ERW	F__
20.4.26	4242	Fieldbus S->M7 sys		ENUM		Not assigned	0	10	ERW	F__
20.4.30	4252	Fieldbus S->M8 sys		ENUM		Not assigned	0	10	ERW	F__
20.4.34	4262	Fieldbus S->M9 sys		ENUM		Not assigned	0	10	ERW	F__
20.4.38	4272	Fieldbus S->M10 sys		ENUM		Not assigned	0	10	ERW	F__
20.4.42	4282	Fieldbus S->M11 sys		ENUM		Not assigned	0	10	ERW	F__
20.4.46	4292	Fieldbus S->M12 sys		ENUM		Not assigned	0	10	ERW	F__
20.4.50	4302	Fieldbus S->M13 sys		ENUM		Not assigned	0	10	ERW	F__
20.4.54	4312	Fieldbus S->M14 sys		ENUM		Not assigned	0	10	ERW	F__
20.4.58	4322	Fieldbus S->M15 sys		ENUM		Not assigned	0	10	ERW	F__
20.4.62	4332	Fieldbus S->M16 sys		ENUM		Not assigned	0	10	ERW	F__

Setting of the format of the datum sent to the channel. When the src parameter is programmed, the format is programmed as **Eu** or **MDPLC 16**. If the src parameter is reset to null, the datum format does not change. The value of the format can be selected from the following list:

- 0 Not assigned
- 1 Count 16
- 2 Count 32
- 3 Fill 16
- 4 Fill 32
- 5 Mdplc 16
- 6 Mdplc 32
- 7 EU
- 8 Eu float
- 9 Par 16
- 10 Par 32

If set to **0** the channel is not assigned.

If set to **1** the datum is assigned a 16-bit count.

If set to **2** the datum is assigned a 32-bit count.

If set to **3** 16 bits on the channel are reserved for the datum, not used.

If set to **4** 32 bits on the channel are reserved for the datum, not used.
 If set to **5** the datum is assigned a 16-bit count used by MDPLC.
 If set to **6** the datum is assigned a 32-bit count used by MDPLC.
 If set to **7** the datum is assigned engineering units on a 16-bit integer.
 If set to **8** the datum is assigned engineering units on a 32-bit integer.
 If set to **9**, the datum is assigned a 16-bit integer engineering unit format not in real time (5-10ms)
 If set to **10** the datum is assigned a 32-bit integer engineering unit format or float format if the associated parameter is a float-type parameter not in real time (5-10ms).

Note!

If the sys parameter is **not assigned**, none of the subsequent channels are transferred to the fieldbus, even if programmed.

Menu	PAR	Description	UM	Type	FB BIT	Def	Min	Max	Acc	Mod
20.4.3	4184	Dig Fieldbus S->M1		INT32	32BIT	0	0	0	ERW	F__
20.4.7	4194	Dig Fieldbus S->M2		INT32	32BIT	0	0	0	ERW	F__
20.4.11	4204	Dig Fieldbus S->M3		INT32	32BIT	0	0	0	ERW	F__
20.4.15	4214	Dig Fieldbus S->M4		INT32	32BIT	0	0	0	ERW	F__
20.4.19	4224	Dig Fieldbus S->M5		INT32	32BIT	0	0	0	ERW	F__
20.4.23	4234	Dig Fieldbus S->M6		INT32	32BIT	0	0	0	ERW	F__
20.4.27	4244	Dig Fieldbus S->M7		INT32	32BIT	0	0	0	ERW	F__
20.4.31	4254	Dig Fieldbus S->M8		INT32	32BIT	0	0	0	ERW	F__
20.4.35	4264	Dig Fieldbus S->M9		INT32	32BIT	0	0	0	ERW	F__
20.4.39	4274	Dig Fieldbus S->M10		INT32	32BIT	0	0	0	ERW	F__
20.4.43	4284	Dig Fieldbus S->M11		INT32	32BIT	0	0	0	ERW	F__
20.4.47	4294	Dig Fieldbus S->M12		INT32	32BIT	0	0	0	ERW	F__
20.4.51	4304	Dig Fieldbus S->M13		INT32	32BIT	0	0	0	ERW	F__
20.4.55	4314	Dig Fieldbus S->M14		INT32	32BIT	0	0	0	ERW	F__
20.4.59	4324	Dig Fieldbus S->M15		INT32	32BIT	0	0	0	ERW	F__
20.4.63	4334	Dig Fieldbus S->M16		INT32	32BIT	0	0	0	ERW	F__

If associated with the relative src, the value of this parameter is sent to the bus.

The user may modify the M->S and by S->M sys parameters. The consistency of the sys with the parameter assigned to the channel is checked.

Menu	PAR	Description	UM	Type	FB BIT	Def	Min	Max	Acc	Mod
20.4.4	4186	Fieldbus S->M1 mul		FLOAT		1.0	1.0	1000.0	ERW	F__
20.4.8	4196	Fieldbus S->M2 mul		FLOAT		1.0	1.0	1000.0	ERW	F__
20.4.12	4206	Fieldbus S->M3 mul		FLOAT		1.0	1.0	1000.0	ERW	F__
20.4.16	4216	Fieldbus S->M4 mul		FLOAT		1.0	1.0	1000.0	ERW	F__
20.4.20	4226	Fieldbus S->M5 mul		FLOAT		1.0	1.0	1000.0	ERW	F__
20.4.24	4236	Fieldbus S->M6 mul		FLOAT		1.0	1.0	1000.0	ERW	F__
20.4.28	4246	Fieldbus S->M7 mul		FLOAT		1.0	1.0	1000.0	ERW	F__
20.4.32	4256	Fieldbus S->M8 mul		FLOAT		1.0	1.0	1000.0	ERW	F__
20.4.36	4266	Fieldbus S->M9 mul		FLOAT		1.0	1.0	1000.0	ERW	F__
20.4.40	4276	Fieldbus S->M10 mul		FLOAT		1.0	1.0	1000.0	ERW	F__
20.4.44	4286	Fieldbus S->M11 mul		FLOAT		1.0	1.0	1000.0	ERW	F__
20.4.48	4296	Fieldbus S->M12 mul		FLOAT		1.0	1.0	1000.0	ERW	F__
20.4.52	4306	Fieldbus S->M13 mul		FLOAT		1.0	1.0	1000.0	ERW	F__
20.4.56	4316	Fieldbus S->M14 mul		FLOAT		1.0	1.0	1000.0	ERW	F__
20.4.60	4326	Fieldbus S->M15 mul		FLOAT		1.0	1.0	1000.0	ERW	F__
20.4.64	4336	Fieldbus S->M16 mul		FLOAT		1.0	1.0	1000.0	ERW	F__

The "Fieldbus S->Mx mul" parameters are multipliers that the drive applies to the datum before sending it to the bus. It is therefore possible to increase the resolution of some values read in EU and EU_float mode, also using decimal digits.

Note!

The drive does not check that the multiplied parameter expressed in bits fits in a 16-bit integer. You must make sure that the multiplier is compatible with the maximum value of the exchanged parameter and that it does not exceed the maximum size of 32768.

Example: **Fieldbus S->Mx mul = 10, S->M1 fieldbus par = Motor speed, Sys S->M1 fieldbus = Eu.**
 If the motor is running at 100 rpm, the PLC reads the value $100 * 10 = 1000$ on the first word that is exchanged.

20.5 - COMMUNICATION/WORD COMP

Menu	PAR	Description	UM	Type	FB BIT	Def	Min	Max	Acc	Mod
20.5.1	4400	Word bit0 src		LINK	16BIT	6000	0	16384	ERW	F__
20.5.2	4402	Word bit1 src		LINK	16BIT	6000	0	16384	ERW	F__
20.5.3	4404	Word bit2 src		LINK	16BIT	6000	0	16384	ERW	F__
20.5.4	4406	Word bit3 src		LINK	16BIT	6000	0	16384	ERW	F__
20.5.5	4408	Word bit4 src		LINK	16BIT	6000	0	16384	ERW	F__
20.5.6	4410	Word bit5 src		LINK	16BIT	6000	0	16384	ERW	F__
20.5.7	4412	Word bit6 src		LINK	16BIT	6000	0	16384	ERW	F__
20.5.8	4414	Word bit7 src		LINK	16BIT	6000	0	16384	ERW	F__
20.5.9	4416	Word bit8 src		LINK	16BIT	6000	0	16384	ERW	F__
20.5.10	4418	Word bit9 src		LINK	16BIT	6000	0	16384	ERW	F__
20.5.11	4420	Word bit10 src		LINK	16BIT	6000	0	16384	ERW	F__
20.5.12	4422	Word bit11 src		LINK	16BIT	6000	0	16384	ERW	F__
20.5.13	4424	Word bit12 src		LINK	16BIT	6000	0	16384	ERW	F__
20.5.14	4426	Word bit13 src		LINK	16BIT	6000	0	16384	ERW	F__
20.5.15	4428	Word bit14 src		LINK	16BIT	6000	0	16384	ERW	F__
20.5.16	4430	Word bit15 src		LINK	16BIT	6000	0	16384	ERW	F__

Selection of the origin (source) of the signal to be used for coding in **Word comp**. This function allows the user to compose a single word composed of 16 signals, each of which can be selected from among those listed in the “**L_DIGSEL1**” selection list”.

The values of the sectioned sizes are converted into a single word.

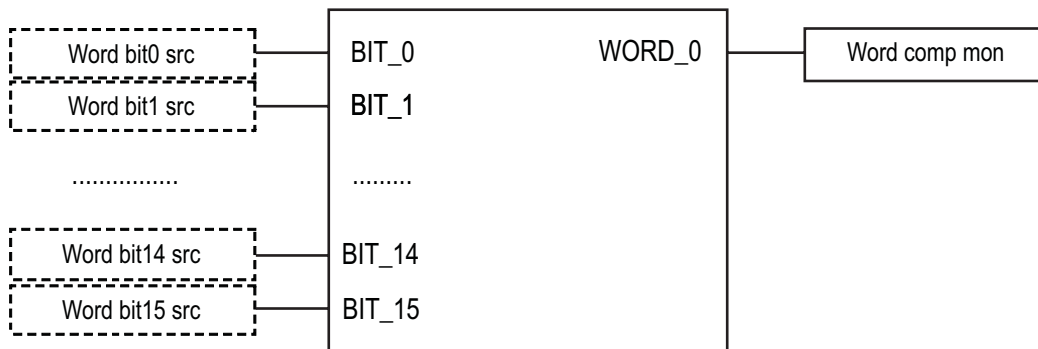

Menu	PAR	Description	UM	Type	FB BIT	Def	Min	Max	Acc	Mod
20.5.17	4432	Word comp mon		UINT32	16BIT	0	0	0	ER	F__

The hexadecimal value of the **Word comp** output is displayed.

20.6 - COMMUNICATION/WORD COMP

Menu	PAR	Description	UM	Type	FB BIT	Def	Min	Max	Acc	Mod
20.6.1	4450	Dig word decomp		UINT32	16BIT	0	0	0	ERW	F__

Setting of the digital input decoded by the “**Word decomp**” block.

Menu	PAR	Description	UM	Type	FB BIT	Def	Min	Max	Acc	Mod
20.6.2	4452	Word decomp src		LINK	16BIT	4450	0	16384	ERW	F__

Selection of the origin (source) of the word to be decoded by the “**Word decomp**” block. Each bit that is part of the word to be decoded is associated with the output channel of the “**Word decomp**” block. The variables that can be used for this function can be selected from among those listed in the “**L_WDECOMP**” selection list”

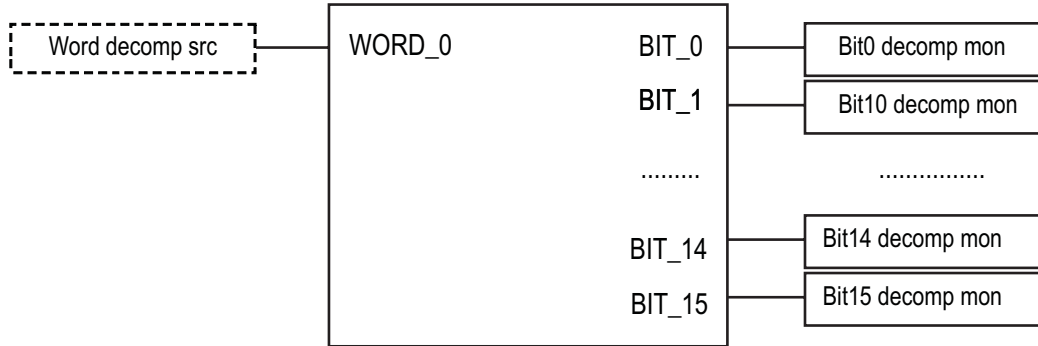

Menu	PAR	Description	UM	Type	FB BIT	Def	Min	Max	Acc	Mod
20.6.3	4454	Bit0 decomp mon		BIT	16BIT	0	0	1	ER	F__
20.6.4	4456	Bit1 decomp mon		BIT	16BIT	0	0	1	ER	F__
20.6.5	4458	Bit2 decomp mon		BIT	16BIT	0	0	1	ER	F__
20.6.6	4460	Bit3 decomp mon		BIT	16BIT	0	0	1	ER	F__
20.6.7	4462	Bit4 decomp mon		BIT	16BIT	0	0	1	ER	F__
20.6.8	4464	Bit5 decomp mon		BIT	16BIT	0	0	1	ER	F__
20.6.9	4466	Bit6 decomp mon		BIT	16BIT	0	0	1	ER	F__
20.6.10	4468	Bit7 decomp mon		BIT	16BIT	0	0	1	ER	F__
20.6.11	4470	Bit8 decomp mon		BIT	16BIT	0	0	1	ER	F__
20.6.12	4472	Bit9 decomp mon		BIT	16BIT	0	0	1	ER	F__
20.6.13	4474	Bit10 decomp mon		BIT	16BIT	0	0	1	ER	F__
20.6.14	4476	Bit11 decomp mon		BIT	16BIT	0	0	1	ER	F__
20.6.15	4478	Bit12 decomp mon		BIT	16BIT	0	0	1	ER	F__
20.6.16	4480	Bit13 decomp mon		BIT	16BIT	0	0	1	ER	F__
20.6.17	4482	Bit14 decomp mon		BIT	16BIT	0	0	1	ER	F__
20.6.18	4484	Bit15 decomp mon		BIT	16BIT	0	0	1	ER	F__

The single bits that make up the selected word are displayed.

21 - ALARM CONFIG

In the ALARM CONFIG menu the type of effect any alarm signals have on the drive is determined:

- The alarm status is saved
- How must the drive react to the alarm signal?
- Auto restart
- Alarm reset

For some alarms, behaviour can be configured separately for each signal, while for the others the **Disable drive** is executed. Individual signals can also be sent to a programmable digital output.

<u>Activity</u>		
Ignore		The alarm is not included in the list of alarms, it is not included in the alarm log, it is not signalled on the digital outputs, no drive commands are modified.
Warning		The alarm is included in the list of alarms, it is included in the alarm log, it is signalled on the digital outputs, the First alarm information is updated, the Alarm enabled information is updated, no drive commands are modified.
Disable Drive		The alarm is included in the list of alarms, it is included in the alarm log, it is signalled on the digital outputs, the First alarm information is updated, the Alarm enabled information is updated, a command is sent to stop and disable the motor, which stops due to inertia.
Stop		The alarm is included in the list of alarms, it is included in the alarm log, it is signalled on the digital outputs, the First alarm information is updated, the Alarm enabled information is updated, a Stop command is sent. When the zero speed is reached the drive is disabled. If Ramp control mode is enabled, the drive moves to the zero speed with the set ramp time; when the Speed delay 0 signal is activated the drive is disabled. If Speed control mode is enabled, the drive moves to the zero speed with the maximum current possible; when the Speed delay 0 signal is activated the drive is disabled. If Torque control mode is enabled, the drive moves to the zero speed with the time set by the load; when the Speed delay 0 signal is activated the drive is disabled.
Fast stop		The alarm is included in the list of alarms, it is included in the alarm log, it is signalled on the digital outputs, the First alarm information is updated, the Alarm enabled information is updated, a Fast Stop command is sent. When the zero speed is reached the drive is disabled. If Ramp control mode is enabled, the drive moves to the zero speed with the set fast stop ramp time (deceleration time 3); when the Speed delay 0 signal is activated the drive is disabled. If Speed control mode is enabled, the drive moves to the zero speed with the maximum current possible; when the Speed delay 0 signal is activated the drive is disabled. If Torque control mode is enabled, the drive moves to the zero speed with the set load time; when the Speed delay 0 signal is activated the drive is disabled.

n alarms with Activity = Ignore or Warning can be enabled at the same time.

If an alarm with Activity = Stop or Fast Stop is enabled and another alarm with an Activity other than Ignore or Warning is enabled, the drive stops and is disabled.

Not all alarms allow the controlled stopping of the drive. The following table shows the possibility of setting the Activities for the individual alarm signals.

Alarm	Ignore	Warning	Disable drive	Stop	Fast stop
ExtFlt	✓	✓	✓	✓	✓
Motor OT	✓	✓	✓	✓	✓
Overspeed	✓	✓	✓	✓	✓
SpdRefLoss	✓	✓	✓	✓	✓
SpdFbkLoss	✓	✓	✓	✓	✓
Drive ovld	✓	✓	✓	✓	✓
Motor ovld	✓	✓	✓	✓	✓
Bres ovld	✓	✓	✓	✓	✓

Alarm	Ignore	Warning	Disable drive	Stop	Fast stop
InAir	✓	✓	✓	✓	✓
PhLoss	✓	✓	✓	✓	✓
Opt Bus	✓	✓	✓	✓	✓
Mot PhLoss	✓	✓	✓	✓	✓

Menu	PAR	Description	UM	Type	FB BIT	Def	Min	Max	Acc	Mod
21.1	4500	Fault reset src		LINK	16BIT	6000	0	16384	RW	F__

Selection of the origin (source) of the signal to be used for the command to reset the drive after an alarm. The terminal that can be used for this function can be selected from among those listed in the “**L_DIGSEL2**” selection list.

Menu	PAR	Description	UM	Type	FB BIT	Def	Min	Max	Acc	Mod
21.2	4502	ExtFlt src		LINK	16BIT	6000	0	16384	RW	F__

Selection of the origin (source) of the signal to be used as the input for the drive external fault alarm **ExtFlt**. The terminal that can be used for this function can be selected from among those listed in the “**L_DIGSEL2**” selection list.

Menu	PAR	Description	UM	Type	FB BIT	Def	Min	Max	Acc	Mod
21.3	4504	ExtFlt activity		ENUM		Disable	0	4	RW	F__

Setting of the behaviour of the drive in the event of an external fault alarm **ExtFlt**. This alarm indicates the intervention of a drive external protection.

- 0 Ignore
- 1 Warning
- 2 Disable
- 3 Stop
- 4 Fast stop

Menu	PAR	Description	UM	Type	FB BIT	Def	Min	Max	Acc	Mod
21.4	4506	ExtFlt restart		ENUM		Disable	0	1	RW	F__

Enabling of automatic restart after the external fault alarm **ExtFlt**

- 0 Disable
- 1 Enable

Menu	PAR	Description	UM	Type	FB BIT	Def	Min	Max	Acc	Mod
21.5	4508	ExtFlt restart time	ms	UINT16		1000	120	30000	RW	F__

Setting of the time within which the **External Fault** alarm must be reset in order to perform automatic restart.

Menu	PAR	Description	UM	Type	FB BIT	Def	Min	Max	Acc	Mod
21.6	4510	ExtFlt holdoff	ms	UINT16		0	0	10000	RW	F__

Setting of the delay between the signalling of the external fault alarm **ExtFlt** and enabling of the alarm. If an alarm condition occurs, the drive will wait for the set time before blocking is enabled. If the alarm is removed within the set time, the drive will not indicate any alarm condition.

Menu	PAR	Description	UM	Type	FB BIT	Def	Min	Max	Acc	Mod
21.7	4520	MotorOT src		LINK	16BIT	6000	0	16384	RW	F__

Selection of the origin (source) of the signal to be used for the motor overtemperature alarm **MotorOT**. The terminal that can be used for this function can be selected from among those listed in the “**L_DIGSEL2**” selection list”.

Menu	PAR	Description	UM	Type	FB BIT	Def	Min	Max	Acc	Mod
21.8	4522	MotorOT activity		ENUM		Avvisa	0	4	RW	F__

Setting of the behaviour of the drive in case of a motor overtemperature alarm **MotorOT**. This alarm indicates that the motor temperature is too high.

- 0 Ignore
- 1 Warning
- 2 Disable
- 3 Stop
- 4 Fast stop

Menu	PAR	Description	UM	Type	FB BIT	Def	Min	Max	Acc	Mod
21.9	4524	MotorOT restart		ENUM		Disable	0	1	RW	F__
		Enabling of automatic restart after the motor overtemperature alarm MotorOT .								
		0 Disable								
		1 Enable								
Menu	PAR	Description	UM	Type	FB BIT	Def	Min	Max	Acc	Mod
21.10	4526	MotorOT restart time	ms	UINT16		1000	120	30000	RW	F__
		Setting of the time within which the Motor Overtemperature alarm must be reset in order to perform automatic restart.								
Menu	PAR	Description	UM	Type	FB BIT	Def	Min	Max	Acc	Mod
21.11	4528	MotorOT holdoff	ms	UINT16		1000	0	30000	RW	F__
		Setting of the delay between the signalling of the motor overtemperature alarm MotorOT and enabling of the alarm. If an alarm condition occurs, the drive will wait for the set time before enabling the alarm. If the alarm is removed within the set time, the drive will not indicate any alarm condition.								
Menu	PAR	Description	UM	Type	FB BIT	Def	Min	Max	Acc	Mod
21.12	4540	Overspeed threshold	rpm	INT16	INT32	CALCI	0	CALCI	RW	F__
		Setting of the threshold above which the overspeed alarm Overspeed is enabled.								
Menu	PAR	Description	UM	Type	FB BIT	Def	Min	Max	Acc	Mod
21.13	4542	Overspeed activity		ENUM		Disable	0	4	RW	F__
		Setting of the behaviour of the drive in case of a motor overspeed alarm Overspeed . This alarm indicates that the motor speed has exceeded the threshold set in the Speed ref top lim and Speed ref bottom lim parameters in the COM-MANDS menu.								
		0 Ignore								
		1 Warning								
		2 Disable								
		3 Stop								
		4 Fast stop								
Menu	PAR	Description	UM	Type	FB BIT	Def	Min	Max	Acc	Mod
21.14	4544	Overspeed holdoff	ms	UINT16		0	0	5000	RW	F__
		Setting of the delay between the signalling of the motor overspeed alarm Overspeed and enabling of the alarm. If an alarm condition occurs, the drive will wait for the set time before enabling the alarm. If the alarm is removed within the set time, the drive will not indicate any alarm condition.								
Menu	PAR	Description	UM	Type	FB BIT	Def	Min	Max	Acc	Mod
21.15	4550	SpdRefLoss threshold	rpm	INT16		100	0	CALCI	RW	F__
		Setting of the threshold below which the speed reference loss alarm SpdRefLoss occurs .								
Menu	PAR	Description	UM	Type	FB BIT	Def	Min	Max	Acc	Mod
21.16	4552	SpdRefLoss activity		ENUM		Avvisa	0	4	RW	F__
		Setting of the behaviour of the drive in case of a speed reference loss alarm SpdRefLoss . This alarm indicates that the difference between the speed regulator reference and the actual motor speed is more than 100 rpm.								
		This alarm must be disabled (= 0 Ignore) when parameter 2354 is set to a value other than zero.								
		This alarm must be disabled (= 1 Disable) when PAR 2132 is set to Digital FP or Digital F or Sinus .								
		This alarm must be disabled (= 1 Disable) when PAR 2136 is set to Peripheral Encoder .								
		0 Ignore								
		1 Warning								
		2 Disable								
		3 Stop								
		4 Fast stop								
Menu	PAR	Description	UM	Type	FB BIT	Def	Min	Max	Acc	Mod
21.17	4554	SpdRefLoss holdoff	ms	UINT16		1000	0	10000	RW	F__
		The delay between the Speed ref loss alarm condition signal and activation of the actual alarm. If an alarm condition occurs, the drive will wait for the set time before enabling the alarm. If the alarm is removed within the set time, the drive will								

not indicate any alarm condition.

Menu	PAR	Description	UM	Type	FB BIT	Def	Min	Max	Acc	Mod
21.18	4560	SpdFbkLoss activity		ENUM		Disable	0	4	RW	F__

Drive behaviour in case of the Speed fbk loss alarm is displayed. This alarm indicates the loss of the encoder feedback signals. Each type of encoder generates the Speed fbk loss alarm differently (incremental signal error, absolute signal error, serial error).

- 0 Ignore
- 1 Warning
- 2 Disable
- 3 Stop
- 4 Fast stop

For absolute Endat encoders and absolute Hiperface encoders, after the alarm is generated, the encoder reset command must be sent to the encoder: during this procedure the application verifies whether the encoder is signalling an encoder alarm condition to the drive and the alarm is acquired from this.

The causes of the **Speed fbk loss** alarm and the information acquired from the encoder are shown in the **SpdFbkLoss code** parameter 2172.

Note!

See menu 15.13 for further information.

Menu	PAR	Description	UM	Type	FB BIT	Def	Min	Max	Acc	Mod
21.19	4562	SpdFbkLoss holdoff	ms	UINT16		200	0	10000	RW	F__

Setting of the delay between the signalling of the speed feedback loss alarm condition **SpdFbkLoss** and the enabling of the alarm. If an alarm condition occurs, the drive will wait for the set time before enabling the alarm. If the alarm is removed within the set time, the drive will not indicate any alarm condition.

Menu	PAR	Description	UM	Type	FB BIT	Def	Min	Max	Acc	Mod
21.20	4564	SpdFbkLoss threshold	rpm	INT16		5	3	CALCI	RW	FV__

If using incremental digital encoders in single-ended mode, this parameter sets the limit above which the drive executes the action set with parameter 4560 **SpdFbkLoss activity**.

Menu	PAR	Description	UM	Type	FB BIT	Def	Min	Max	Acc	Mod
21.21	4570	Drive ovid activity		ENUM		Disable	0	4	ERW	F__

Setting of the behaviour of the drive in case of a drive overload alarm **Drive ovid**. This alarm indicates that the drive overload threshold has been reached.

- 0 Ignore
- 1 Warning
- 2 Disable
- 3 Stop
- 4 Fast stop

Menu	PAR	Description	UM	Type	FB BIT	Def	Min	Max	Acc	Mod
21.22	4572	Motor ovid activity		ENUM		Avvisa	0	4	ERW	F__

Setting of the behaviour of the drive in case of a motor overload alarm **Motor ovid**. This alarm indicates that the motor overload threshold has been reached.

- 0 Ignore
- 1 Warning
- 2 Disable
- 3 Stop
- 4 Fast stop

Menu	PAR	Description	UM	Type	FB BIT	Def	Min	Max	Acc	Mod
21.23	4574	Bres ovid activity		ENUM		Disable	0	4	ERW	F__

Setting of the behaviour of the drive in case of a braking resistor overload alarm **Bres ovid**. This alarm indicates that the braking resistor overload threshold has been reached.

- 0 Ignore
- 1 Warning
- 2 Disable
- 3 Stop
- 4 Fast stop

Menu	PAR	Description	UM	Type	FB BIT	Def	Min	Max	Acc	Mod
21.24	4582	HTsens restart		ENUM		Disable	0	1	ERW	F__
		Enabling of automatic restart after the drive heatsink overtemperature alarm HTsens .								
		0 Disable								
		1 Enable								
Menu	PAR	Description	UM	Type	FB BIT	Def	Min	Max	Acc	Mod
21.25	4584	HTsens restart time	ms	UINT16		20000	120	60000	ERW	F__
		Setting of the time within which the HT sensor alarm must be reset in order to perform automatic restart.								
Menu	PAR	Description	UM	Type	FB BIT	Def	Min	Max	Acc	Mod
21.26	4600	InAir activity		ENUM		Arresto	0	4	ERW	F__
		Setting of the behaviour of the drive in case of an intake air overtemperature alarm InAir . This alarm indicates that the temperature of the intake cooling air is too high.								
		0 Ignore								
		1 Warning								
		2 Disable								
		3 Stop								
		4 Fast stop								
Menu	PAR	Description	UM	Type	FB BIT	Def	Min	Max	Acc	Mod
21.27	4602	InAir restart		ENUM		Disable	0	1	ERW	F__
		Enabling of automatic restart after the intake air overtemperature alarm InAir .								
		0 Disable								
		1 Enable								
Menu	PAR	Description	UM	Type	FB BIT	Def	Min	Max	Acc	Mod
21.28	4604	InAir restart time	ms	UINT16		1000	120	30000	ERW	F__
		Setting of the time within which the Intakeair OT alarm must be reset in order to perform automatic restart.								
Menu	PAR	Description	UM	Type	FB BIT	Def	Min	Max	Acc	Mod
21.29	4606	InAir holdoff	ms	UINT16		10000	0	30000	ERW	F__
		Setting of the delay between the signalling of the intake air overtemperature alarm InAir and enabling of the alarm. If an alarm condition occurs, the drive will wait for the set time before enabling the alarm. If the alarm is removed within the set time, the drive will not indicate any alarm condition.								
Menu	PAR	Description	UM	Type	FB BIT	Def	Min	Max	Acc	Mod
21.30	4610	Desat restart		ENUM		Disable	0	1	ERW	F__
		Enabling of automatic restart after the desaturation alarm Desat . This alarm indicates a short circuit between the motor phases or on the power bridge.								
		0 Disable								
		1 Enable								
Menu	PAR	Description	UM	Type	FB BIT	Def	Min	Max	Acc	Mod
21.31	4612	Desat restart time	ms	UINT16		2000	1000	10000	ERW	F__
		Setting of the time within which the Desaturation alarm must be reset in order to perform automatic restart. (Time with alarm signal active + 1000 msec).								
Menu	PAR	Description	UM	Type	FB BIT	Def	Min	Max	Acc	Mod
21.32	4620	IOverC restart		ENUM		Disable	0	1	ERW	F__
		Enabling of automatic restart after the drive Overcurrent alarm. This alarm indicates an overcurrent (or short circuit between phases or towards the ground).								
		0 Disable								
		1 Enable								
Menu	PAR	Description	UM	Type	FB BIT	Def	Min	Max	Acc	Mod
21.33	4622	IOverC restart time	ms	UINT16		2000	1000	10000	ERW	F__

Setting of the time within which the **Overcurrent** alarm must be reset in order to perform automatic restart. (Time with alarm signal active + 1000 msec).

Menu	PAR	Description	UM	Type	FB BIT	Def	Min	Max	Acc	Mod
21.34	4630	OverV restart		ENUM		Disable	0	1	ERW	F__
		Enabling of automatic restart after the Overvoltage alarm. This alarm indicates an overvoltage on the intermediate circuit (DC link)								
		0 Disable								
		1 Enable								

Menu	PAR	Description	UM	Type	FB BIT	Def	Min	Max	Acc	Mod
21.35	4632	OverV restart time	ms	UINT16		2000	1000	10000	ERW	F__
		Setting of the time within which the Overvoltage alarm must be reset in order to perform automatic restart. (Time with alarm signal active + 1000 msec).								

Menu	PAR	Description	UM	Type	FB BIT	Def	Min	Max	Acc	Mod
21.36	4640	UnderV restart		ENUM		Enable	0	1	ERW	F__
		Enabling of automatic restart after the Undervoltage alarm. This alarm indicates an undervoltage on the intermediate circuit (DC link).								
		0 Disable								
		1 Enable								

Menu	PAR	Description	UM	Type	FB BIT	Def	Min	Max	Acc	Mod
21.37	4642	UnderV restart time	ms	UINT16		1000	120	10000	ERW	F__
		Setting of the time within which the Undervoltage alarm must be reset in order to perform automatic restart. (Time with alarm signal active + 100 msec).								

Menu	PAR	Description	UM	Type	FB BIT	Def	Min	Max	Acc	Mod
21.38	4650	UVRep attempts		UINT16		5	0	1000	ERW	F__
		Setting of the maximum number of attempts at automatic restart after the Undervoltage alarm before a Mult Undervoltage alarm is generated. If this parameter is set to 1000 an infinite number of attempts are available.								

Menu	PAR	Description	UM	Type	FB BIT	Def	Min	Max	Acc	Mod
21.39	4652	UVRep delay	s	UINT16		240	0	300	ERW	F__
		Setting of the time within which, if no automatic restarts are executed after the Undervoltage alarm, the attempts counter is reset. In this way the number of attempts set in Underv res attempts are still available.								

Menu	PAR	Description	UM	Type	FB BIT	Def	Min	Max	Acc	Mod
21.40	4660	PhLoss activity		ENUM		Disable	0	4	ERW	F__
		Setting of the behaviour of the drive in case of a no phase alarm. This alarm indicates the absence of a drive power supply phase.								
		0 Ignore								
		1 Warning								
		2 Disable								
		3 Stop								
		4 Fast stop								

Menu	PAR	Description	UM	Type	FB BIT	Def	Min	Max	Acc	Mod
21.41	4662	PhLoss restart		ENUM		Disable	0	1	ERW	F__
		Enabling of automatic restart after the no phase alarm.								
		0 Disable								
		1 Enable								

Menu	PAR	Description	UM	Type	FB BIT	Def	Min	Max	Acc	Mod
21.42	4664	PhLoss restart time	ms	UINT16		1000	120	10000	ERW	F__
		Setting of the time within which the Phase loss alarm must be reset in order to perform automatic restart. (Time with alarm signal active + 100 msec).								

Menu	PAR	Description	UM	Type	FB BIT	Def	Min	Max	Acc	Mod
21.43	4668	PhLoss output test		ENUM		Enable	0	2	ERWZ	F__

Enabling of the output phase loss test.

- 0 Disable
- 1 Enable
- 2 Powerup

If set to **0** the test is disable

If set to **1** the drive verifies the presence of all the output phases each time it receives the enable command.

If set to **2** the drive only verifies the presence of all the output phases the first time the enable command is sent after powering

Note!

The motor brake must be closed while running this test!

Menu	PAR	Description	UM	Type	FB BIT	Def	Min	Max	Acc	Mod
21.44	4654	Mot PhLoss activity		ENUM		Ignore	0	4	ERW	FVS

“Motor Phase Loss” function detect the drop of one phase connecting the drive to the motor. This function works both when the motor is rotating. To configure the Phase Loss function the parameters 4654-4656-4674 and 4678 are available.

The “Motor phase loss” alarm signals the loss of a motor phase. This parameter manages the alarm activity.

- 0 Ignore
- 1 Warning
- 2 Disable
- 3 Stop
- 4 Fast stop

Menu	PAR	Description	UM	Type	FB BIT	Def	Min	Max	Acc	Mod
22.45	4656	Mot PhLoss holdoff	ms	UINT16		800	200	10000	ERW	FVS

Represents the time the alarm condition has to persist before the alarm is actually generated.

Menu	PAR	Description	UM	Type	FB BIT	Def	Min	Max	Acc	Mod
22.46	4674	Mot PhLoss speed thr	rpm	INT16		10	10	32000	ERW	FVS

In case of failure of the connection between a phase of the motor and the drive, the alarm signal is active when it is exceeded the speed threshold set in this parameter.

It can be used to mask the alarm at very low speed during the start and stop transients when external noise could cause false alarm tripping.

Menu	PAR	Description	UM	Type	FB BIT	Def	Min	Max	Acc	Mod
21.47	4678	Mot PhLoss code		UINT32		0	0	0	ER	FVS

The hexadecimal value contains information about the type of problem detected and the motor phase where there is the anomaly.

0x0001	Error detected on phase U with motor running
0x0002	Error detected on phase V with motor running
0x0004	Error detected on phase W with motor running
0x0008	Error detected on phase U with motor running and speed ref loss
0x0010	Error detected on phase V with motor running and speed ref loss
0x0020	Error detected on phase W with motor running and speed ref loss
0x0040	Error detected on phase U during magnetizing stage (Asynchronous motor only)
0x0080	Error detected on phase V during magnetizing stage (Asynchronous motor only)
0x0100	Error detected on phase W during magnetizing stage (Asynchronous motor only)
0x0200	Error detected on phase U with motor disabled (Asynchronous motor only)
0x0400	Error detected on phase V with motor disabled (Asynchronous motor only)
0x0800	Error detected on phase W with motor disabled (Asynchronous motor only)

In some cases it is possible that more bit are showed at the same time. Depending on the type of fault, in fact, if the interruption of one phase makes that even in the other two there is no more current circulation, the displayed code indicates the absence of all three phases, while being just one connection failed.

Menu	PAR	Description	UM	Type	FB BIT	Def	Min	Max	Acc	Mod
21.48	4670	Optionbus activity		ENUM		Disable	0	4	ERW	F__

Setting of the behaviour of the drive in case of an “Opt Bus Fault” alarm.

- 0 Ignore
- 1 Warning
- 2 Disable
- 3 Stop
- 4 Fast stop

Menu	PAR	Description	UM	Type	FB BIT	Def	Min	Max	Acc	Mod
21.49	4680	GroundFault thr	perc	FLOAT		10.0	0.0	150.0	ERWS	F__

Setting of the threshold for the ground short circuit alarm **Ground Fault**.

Menu	PAR	Description	UM	Type	FB BIT	Def	Min	Max	Acc	Mod
21.50	4700	Alarm dig sel 1		ENUM		Nessun allarme	0	40	ERW	F__
21.51	4702	Alarm dig sel 2		ENUM		Nessun allarme	0	40	ERW	F__
21.52	4704	Alarm dig sel 3		ENUM		Nessun allarme	0	40	ERW	F__
21.53	4706	Alarm dig sel 4		ENUM		Nessun allarme	0	40	ERW	F__

Setting of the alarm signal to enable on a digital output. The digital output is selected using parameters **Alm dig out mon 1÷4**, which can be enabled in the **L_DIGSEL1** selection list.

- 0 No alarm
- 1 Overvoltage
- 2 Undervoltage
- 3 Ground fault
- 4 Overcurrent
- 5 Desaturation
- 6 MultiUndervolt
- 7 MultiOvercurr
- 8 MultiDesat
- 9 Heatsink OT
- 10 HeatsinkS OTUT
- 11 Intakeair OT
- 12 Motor OT
- 13 Drive overload
- 14 Motor overload
- 15 Bres overload
- 16 Phaseloss
- 17 Opt Bus fault
- 18 Opt 1 IO fault
- 19 Opt 2 IO fault
- 20 Opt Enc fault
- 21 External fault
- 22 Speed fbk loss
- 23 Overspeed
- 24 Speed ref loss
- 25 Emg stop alarm
- 26 Power down
- 27 Phaseloss out
- 28 OV safety
- 29 Safety failure
- 30 Mot phase loss
- 31 Ropes change
- 32 Not Used
- 33 Plc1 fault
- 34 Plc2 fault
- 35 Plc3 fault
- 36 Plc4 fault
- 37 Plc5 fault
- 38 Plc6 fault
- 39 Plc7 fault
- 40 Plc8 fault

Menu	PAR	Description	UM	Type	FB BIT	Def	Min	Max	Acc	Mod
21.54	4720	Alm autoreset time	s	FLOAT		0.0	0.0	60.0	ERW	F__

Setting of the time interval that must pass before executing an automatic reset.

If no alarms are enabled the drive is set to restart.

If some alarms are still enabled the drive is set to execute a new attempt at automatic reset.

At each attempted reset a counter increases. If the limit set in the Alm autoreset number parameter is reached the drive is set to make no more attempts at reset and waits for a user reset.

The counter is set to zero when an automatic reset or user reset is performed and no alarms are enabled.

If the parameter is 0 the function is disabled.

Menu	PAR	Description	UM	Type	FB BIT	Def	Min	Max	Acc	Mod
21.55	4722	Alm autoreset number		UINT16		20	0	100	ERW	F__

Setting of the maximum number of attempted automatic resets.

23 - ALARM LOG

This is the menu in which the log of previous alarms is saved, with the time the alarm occurred (in relation to the **Time drive power** on parameter). The alarms are displayed starting from the most recent (No. 1) up to the furthest back in time (No. 30). Up to 30 alarm signals can be displayed. The sub-code is used by service technicians to identify the specific type of alarm. Press the ▲ and ▼ keys to scroll the screen pages of the alarm log. The alarm log cannot be deleted.

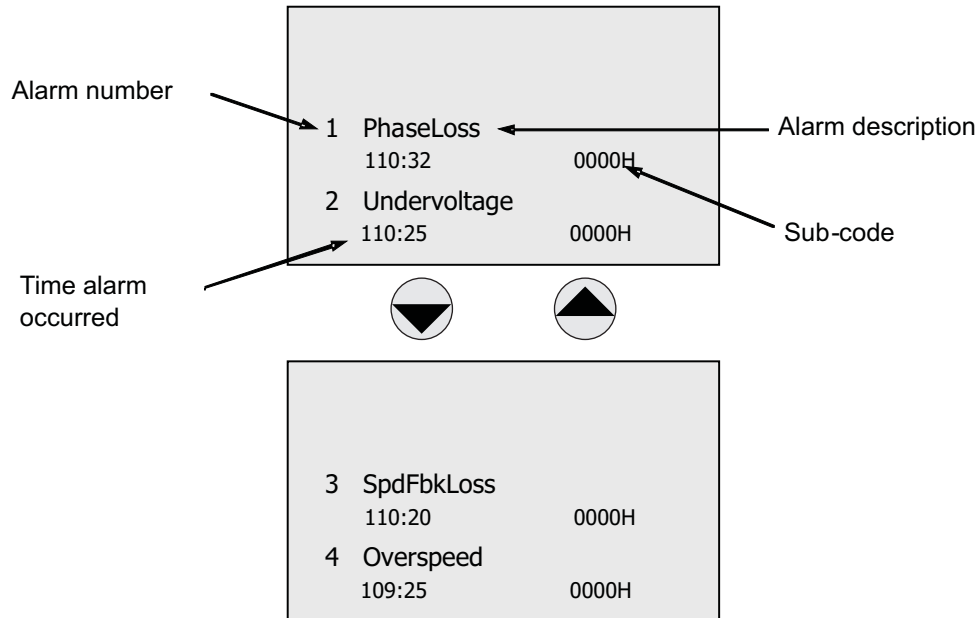

PARAMETERS ON SELECTION LISTS, BUT NOT DISPLAYED ON KEYPAD

This list reports the parameters that are not displayed in the keyboard while they are part of the selection lists. These parameters can be used as SOURCE of the input signals for the function block. (Refer to section A – Programming).

Menu	PAR	Description	UM	Type	FB BIT	Def	Min	Max	Acc	Mod
-	262	Motor speed nofilter	rpm	INT16	16BIT	0	0	0	ER	F__

This parameter indicates the unfiltered motor speed.

Menu	PAR	Description	UM	Type	FB BIT	Def	Min	Max	Acc	Mod
-	362	Drive overload trip		BIT	16BIT	0	0	1	ER	F__

This signal indicates that the drive is in the overload alarm condition.

Menu	PAR	Description	UM	Type	FB BIT	Def	Min	Max	Acc	Mod
-	366	Drive overload 80%		BIT	16BIT	0	0	1	ER	F__

This signal indicates that the drive has reached 80% of the thermal image accumulator (drive overload).

Menu	PAR	Description	UM	Type	FB BIT	Def	Min	Max	Acc	Mod
-	626	Ramp ref out mon	rpm	INT16	16BIT	0	0	0	ER	F__

This parameter displays the reference value output of the ramp remference function block.

Menu	PAR	Description	UM	Type	FB BIT	Def	Min	Max	Acc	Mod
-	760	Ramp out mon	rpm	INT16	16BIT	0	0	0	ER	F__

This parameter displays the reference value output of the ramp function block.

Menu	PAR	Description	UM	Type	FB BIT	Def	Min	Max	Acc	Mod
-	764	Ramp acc state		BIT	16BIT	0	0	1	ER	F__

This signal indicates whether the acceleration ramp is active.

Menu	PAR	Description	UM	Type	FB BIT	Def	Min	Max	Acc	Mod
-	766	Ramp dec state		BIT	16BIT	0	0	1	ER	F__

This signal indicates whether the deceleration ramp is active.

Menu	PAR	Description	UM	Type	FB BIT	Def	Min	Max	Acc	Mod
-	934	Ref is 0		BIT	16BIT	0	0	1	ER	F__

This signal is active when the reference is below the limit set in parameter **930 Reference 0 threshold**.

Menu	PAR	Description	UM	Type	FB BIT	Def	Min	Max	Acc	Mod
-	936	Ref is 0 delay		BIT	16BIT	0	0	1	ER	F__

This parameter is active when the reference is below the threshold set in parameter **930 Reference 0 threshold**. The signal is enabled after the delay set with parameter **932 Reference delay 0**.

Menu	PAR	Description	UM	Type	FB BIT	Def	Min	Max	Acc	Mod
-	944	Speed is 0		BIT	16BIT	0	0	1	ER	F__

This parameter is active when the speed is below the threshold set in parameter **940 Speed 0 threshold**.

Menu	PAR	Description	UM	Type	FB BIT	Def	Min	Max	Acc	Mod
-	946	Speed is 0 delay		BIT	16BIT	0	0	1	ER	F__

This signal is active when the reference is below the threshold set in parameter **940 Speed 0 threshold**. The signal is activated after the delay set in parameter **942 Speed 0 delay**.

Menu	PAR	Description	UM	Type	FB BIT	Def	Min	Max	Acc	Mod
-	1060	Sequencer status		UINT16	16BIT	0	0	0	ER	F__
		This signal indicates the state of the “machine states” that controls drive operation.								
		STS_INIT		0						
		STS_MAGN		1						
		STS_STOP		2						
		STS_START		3						
		STS_FS_STOP		4						
		STS_FS_START		5						
		STS_QSTOP		6						
		STS_FS_MAGN		7						
		STS_W_QSTOP		8						
		STS_READY		9						
		STS_MAGN_START		10						
		STS_ALM_DISABLED		11						
		STS_ALM_END_ACTION		12						
		STS_ALM_STOP		13						
		STS_ALM_FSTOP		14						
		STS_ALM_R_TO_NORMAL		15						
		STS_READY_START		16						
		STS_READY_FSTOP		17						
		STS_ALM_NO_RESTART		18						
		STS_FS_MAGN_START		19						

Menu	PAR	Description	UM	Type	FB BIT	Def	Min	Max	Acc	Mod
-	1062	Drive OK		BIT	16BIT	0	0	1	ER	F__
		This signal is active when the drive is in the “OK” condition and no alarms are present.								

Menu	PAR	Description	UM	Type	FB BIT	Def	Min	Max	Acc	Mod
-	1064	Drive ready		BIT	16BIT	0	0	1	ER	F__
		This signal is active when the drive reference is in the “Ready” to run condition.								

Menu	PAR	Description	UM	Type	FB BIT	Def	Min	Max	Acc	Mod
-	1110	Digital input E mon		BIT	16BIT	0	0	1	ER	F__
		These signals represent the state of the corresponding digital input.								

Menu	PAR	Description	UM	Type	FB BIT	Def	Min	Max	Acc	Mod
-	1210	Digital input 1X mon		BIT	16BIT	0	0	1	ER	F__
-	1212	Digital input 2X mon		BIT	16BIT	0	0	1	ER	F__
-	1214	Digital input 3X mon		BIT	16BIT	0	0	1	ER	F__
-	1216	Digital input 4X mon		BIT	16BIT	0	0	1	ER	F__
-	1218	Digital input 5X mon		BIT	16BIT	0	0	1	ER	F__
-	1220	Digital input 6X mon		BIT	16BIT	0	0	1	ER	F__
-	1222	Digital input 7X mon		BIT	16BIT	0	0	1	ER	F__
-	1224	Digital input 8X mon		BIT	16BIT	0	0	1	ER	F__
-	1226	Digital input 9X mon		BIT	16BIT	0	0	1	ER	F__
-	1228	Digital input 10X mon		BIT	16BIT	0	0	1	ER	F__
-	1230	Digital input 11X mon		BIT	16BIT	0	0	1	ER	F__
-	1232	Digital input 12X mon		BIT	16BIT	0	0	1	ER	F__

These signals represent the state of the corresponding digital input on the expansion card.

Menu	PAR	Description	UM	Type	FB BIT	Def	Min	Max	Acc	Mod
-	2388	Torque ref nofilter	perc	FLOAT	16BIT	0.0	0.0	0.0	ER	F__
		The torque control reference current without filter is displayed (in sensorless vector and field-oriented vector mode).								

Menu	PAR	Description	UM	Type	FB BIT	Def	Min	Max	Acc	Mod
-	3214	Motor overload trip		BIT	16BIT	0	0	1	ER	F__
		This signal is active when the drive is in the motor overload alarm condition.								
-	3262	Bres overload trip		BIT	16BIT	0	0	1	ER	F__
		This signal is active when the drive is in the braking resistor overload alarm condition.								
-	3422	Direction change mon		BIT	16BIT	0	0	1	ER	FVS
		This signal stays on for one second each time the drive detects a direction change and thus decrements the counter. This signal is inserted in the L_DIGSEL1 selection list and can be brought to a digital output.								
-	3424	Dir change cnt zero		BIT	16BIT	0	0	1	ER	FVS
		This signal activates when the drive is locked because 3414 Direction counter has reached 0. This signal is inserted in the L_DIGSEL1 selection list and can be brought to a digital output.								
-	4708	Alm dig out mon 1		BIT	16BIT	0	0	1	ER	F__
		This signal is activated when the alarm configured in parameter 4700 alarm dig sel 1 is active.								
-	4710	Alm dig out mon 2		BIT	16BIT	0	0	1	ER	F__
		This signal is activated when the alarm configured in parameter 4702 alarm dig sel 2 is active.								
-	4712	Alm dig out mon 3		BIT	16BIT	0	0	1	ER	F__
		This signal is activated when the alarm configured in parameter 4704 alarm dig sel 3 is active.								
-	4714	Alm dig out mon 4		BIT	16BIT	0	0	1	ER	F__
		This signal is activated when the alarm configured in parameter 4706 alarm dig sel 4 is active.								
-	4770	First alarm		UINT32	16BIT	0	0	0	ERW	F__
		This parameter displays the first alarm to be activated..								
		0 No alarm								
		1 Overvoltage								
		2 Undervoltage								
		3 Ground fault								
		4 Overcurrent								
		5 Desaturation								
		6 MultiUndervolt								
		7 MultiOvercurr								
		8 MultiDesat								
		9 Heatsink OT								
		10 HeatsinkS OTUT								
		11 Intakeair OT								
		12 Motor OT								
		13 Drive overload								
		14 Motor overload								
		15 Bres overload								
		16 Phaseloss								
		17 Opt Bus fault								
		18 Opt 1 IO fault								
		19 Opt 2 IO fault								
		20 Opt Enc fault								

- 21 External fault
- 22 Speed fbk loss
- 23 Overspeed
- 24 Speed ref loss
- 25 Emg stop alarm
- 26 Power down
- 27 Phaseloss out
- 28 OV safety
- 29 Safety failure
- 30 Mot phase loss
- 31 Ropes change
- 32 Not Used
- 33 Plc1 fault
- 34 Plc2 fault
- 35 Plc3 fault
- 36 Plc4 fault
- 37 Plc5 fault
- 38 Plc6 fault
- 39 Plc7 fault
- 40 Plc8 fault

Menu	PAR	Description	UM	Type	FB BIT	Def	Min	Max	Acc	Mod
-	4780	Alarm PLC		UINT16		0	0	0	ER	F__

This parameter displays the state of the alarms generated by the application written with the internal PLC.

Bit	Description
0	1 = PLC 1 fault active
1	1 = PLC 2 fault active
2	1 = PLC 3 fault active
3	1 = PLC 4 fault active
4	1 = PLC 5 fault active
5	1 = PLC 6 fault active
6	1 = PLC 7 fault active
7	1 = PLC 8 fault active

Menu	PAR	Description	UM	Type	FB BIT	Def	Min	Max	Acc	Mod
-	6000	Null		UINT32 32BIT		0	0	0	ER	F__

This signal forces the variable to the zero level (always disabled).

Menu	PAR	Description	UM	Type	FB BIT	Def	Min	Max	Acc	Mod
-	6002	One		UINT32 32BIT		1	1	1	ER	F__

This signal forces the variable to level one (always active)..

Menu	PAR	Description	UM	Type	FB BIT	Def	Min	Max	Acc	Mod
-	6006	Current limit state		BIT	16BIT	0	0	1	ER	F__

This signal is activated when the drive is in the current limit condition.

Menu	PAR	Description	UM	Type	FB BIT	Def	Min	Max	Acc	Mod
-	6372	DS417 status word		UINT16 16BIT		0	0	65535	ER	FVS

This parameter displays the status word according to the DS417 Profile. For more information reference should be made to the fieldbus manual.

C - SELECTION LISTS

PAR	Description	Menu	PAR	Description	Menu	PAR	Description	Menu
L_ANOUT			760	Ramp out mon	(*)	1214	Digital input 3X mon	(*)
6000	Null	(*)	664	Speed setpoint	1.5	1216	Digital input 4X mon	(*)
626	Ramp ref out mon	(*)	260	Motor speed	1.6	1218	Digital input 5X mon	(*)
760	Ramp out mon	(*)	262	Motor speed nofilter	(*)	1220	Digital input 6X mon	(*)
664	Speed setpoint	1.5	2150	Encoder speed	15.17	1222	Digital input 7X mon	(*)
260	Motor speed	1.6	250	Output current	1.1	1224	Digital input 8X mon	(*)
262	Motor speed nofilter	(*)	252	Output voltage	1.2	1226	Digital input 9X mon	(*)
2150	Encoder speed	15.17	254	Output frequency	1.3	1228	Digital input 10X mon	(*)
250	Output current	1.1	280	Torque current ref	1.9	1230	Digital input 11X mon	(*)
252	Output voltage	1.2	282	Magnet current ref	1.10	1232	Digital input 12X mon	(*)
254	Output frequency	1.3	284	Torque current	1.11	1062	Drive OK	(*)
280	Torque current ref	1.9	286	Magnet current	1.12	1064	Drive ready	(*)
282	Magnet current ref	1.10	2386	Torque ref	18.10	934	Ref is 0	(*)
284	Torque current	1.11	2388	Torque ref nofilter	(*)	936	Ref is 0 delay	(*)
286	Magnet current	1.12	270	DC link voltage	1.7	944	Speed is 0	(*)
2360	Torque climPos Inuse	18.5	1600	Analog input 1X mon	12.1	946	Speed is 0 delay	(*)
2362	Torque climNeg Inuse	18.6	1650	Analog input 2X mon	12.12	1066	Enable state mon	1.16
2386	Torque ref	18.10	368	Drive overload accum	1.14	1068	Start state mon	1.17
2388	Torque ref nofilter	(*)	3212	Motor overload accum	1.13	1070	FastStop state mon	1.18
270	DC link voltage	1.7	3260	Bres overload accum	1.15	1024	Enable cmd mon	9.9
3104	Inertia comp mon	19.1.3	4024	Fieldbus M->S1 mon	20.3.3	1026	Start cmd mon	9.10
1600	Analog input 1X mon	12.1	4034	Fieldbus M->S2 mon	20.3.7	1028	FastStop cmd mon	9.11
1650	Analog input 2X mon	12.12	4044	Fieldbus M->S3 mon	20.3.11	4708	Alm dig out mon 1	(*)
368	Drive overload accum	1.14	4054	Fieldbus M->S4 mon	20.3.15	4710	Alm dig out mon 2	(*)
3212	Motor overload accum	1.13	4064	Fieldbus M->S5 mon	20.3.19	4712	Alm dig out mon 3	(*)
3260	Bres overload accum	1.15	4074	Fieldbus M->S6 mon	20.3.23	4714	Alm dig out mon 4	(*)
2232	Spd reg P gain Inuse	16.16	4084	Fieldbus M->S7 mon	20.3.27	362	Drive overload trip	(*)
2234	Spd reg I gain Inuse	16.17	4094	Fieldbus M->S8 mon	20.3.31	3214	Motor overload trip	(*)
4024	Fieldbus M->S1 mon	20.3.3	4104	Fieldbus M->S9 mon	20.3.35	3262	Bres overload trip	(*)
4034	Fieldbus M->S2 mon	20.3.7	4114	Fieldbus M->S10 mon	20.3.39	366	Drive overload 80%	(*)
4044	Fieldbus M->S3 mon	20.3.11	4124	Fieldbus M->S11 mon	20.3.43	4454	Bit0 decomp mon	20.6.3
4054	Fieldbus M->S4 mon	20.3.15	4134	Fieldbus M->S12 mon	20.3.47	4456	Bit1 decomp mon	20.6.4
4064	Fieldbus M->S5 mon	20.3.19	4144	Fieldbus M->S13 mon	20.3.51	4458	Bit2 decomp mon	20.6.5
4074	Fieldbus M->S6 mon	20.3.23	4154	Fieldbus M->S14 mon	20.3.55	4460	Bit3 decomp mon	20.6.6
4084	Fieldbus M->S7 mon	20.3.27	4164	Fieldbus M->S15 mon	20.3.59	4462	Bit4 decomp mon	20.6.7
4094	Fieldbus M->S8 mon	20.3.31	4174	Fieldbus M->S16 mon	20.3.63	4464	Bit5 decomp mon	20.6.8
4104	Fieldbus M->S9 mon	20.3.35	3700	Lift enable	19.6.1	4466	Bit6 decomp mon	20.6.9
4114	Fieldbus M->S10 mon	20.3.39	3702	Run cont mon	19.6.2	4468	Bit7 decomp mon	20.6.10
4124	Fieldbus M->S11 mon	20.3.43	3704	Up cont mon	19.6.3	4470	Bit8 decomp mon	20.6.11
4134	Fieldbus M->S12 mon	20.3.47	3706	Down cont mon	19.6.4	4472	Bit9 decomp mon	20.6.12
4144	Fieldbus M->S13 mon	20.3.51	3708	Brake cont mon	19.6.5	4474	Bit10 decomp mon	20.6.13
4154	Fieldbus M->S14 mon	20.3.55	3710	Lift dc brake	19.6.6	4476	Bit11 decomp mon	20.6.14
4164	Fieldbus M->S15 mon	20.3.59	3712	Brake 2 mon	19.6.7	4478	Bit12 decomp mon	20.6.15
4174	Fieldbus M->S16 mon	20.3.63	3714	Door open mon	19.6.8	4480	Bit13 decomp mon	20.6.16
3700	Lift enable	19.6.1	3716	Lift start	19.6.9	4482	Bit14 decomp mon	20.6.17
3702	Run cont mon	19.6.2	3718	Pad 10	19.6.10	4484	Bit15 decomp mon	20.6.18
3704	Up cont mon	19.6.3	3720	Lift status word	19.6.11	3700	Lift enable	19.6.1
3706	Down cont mon	19.6.4	3722	Pad 12	19.6.12	3702	Run cont mon	19.6.2
3708	Brake cont mon	19.6.5	3724	Pad 13	19.6.13	3704	Up cont mon	19.6.3
3710	Lift dc brake	19.6.6	3726	Ramp down limit	19.6.14	3706	Down cont mon	19.6.4
3712	Brake 2 mon	19.6.7	3728	PAD 15	19.6.15	3708	Brake cont mon	19.6.5
3714	Door open mon	19.6.8	3730	Lift wdec input	19.6.16	3710	Lift dc brake	19.6.6
3716	Lift start	19.6.9				3712	Brake 2 mon	19.6.7
3718	Pad 10	19.6.10	(1) the XXXX parameter changes according to the src parameter used:			3714	Door open mon	19.6.8
3720	Lift status word	19.6.11	3660 Compare input 1 src			3716	Lift start	19.6.9
3722	Pad 12	19.6.12	(1) = 3650 Dig compare input 1	19.5.1		3718	Pad 10	19.6.10
3724	Pad 13	19.6.13	3662 Compare input 2 src			3720	Lift status word	19.6.11
3726	Ramp down limit	19.6.14	(1) = 3652 Dig compare input 2	19.5.2		3722	Pad 12	19.6.12
3728	PAD 15	19.6.15				3724	Pad 13	19.6.13
3730	Lift wdec input	19.6.16				3726	Ramp down limit	19.6.14
5008	Test gen out	23.1.5				3728	PAD 15	19.6.15
L_CMP						3730	Lift wdec input	19.6.16
XXXX ⁽¹⁾			L_DIGSEL1			6006	Current limit state	(*)
626	Ramp ref out mon	(*)	6000	Null	(*)	764	Ramp acc state	(*)
			6002	One	(*)	766	Ramp dec state	(*)
			1110	Digital input E mon	(*)	4780	Alarm PLC	(*)
			1210	Digital input 1X mon	(*)	3676	Compare output	19.5.8
			1212	Digital input 2X mon	(*)	3420	Ropes change req mon	19.7.11

PAR	Description	Menu	PAR	Description	Menu	PAR	Description	Menu
3422	Direction change mon	(*)	1064	Drive ready	(*)	6002	One	(*)
3424	Dir change cnt zero	(*)	934	Ref is 0	(*)	626	Ramp ref out mon	(*)
L_DIGSEL2								
6000	Null	(*)	936	Ref is 0 delay	(*)	760	Ramp out mon	(*)
6002	One	(*)	944	Speed is 0	(*)	664	Speed setpoint	1.5
1110	Digital input E mon	(*)	946	Speed is 0 delay	(*)	260	Motor speed	1.6
1210	Digital input 1X mon	(*)	1066	Enable state mon	1.16	262	Motor speed nofilter	(*)
1212	Digital input 2X mon	(*)	1068	Start state mon	1.17	2150	Encoder speed	15.17
1214	Digital input 3X mon	(*)	1070	FastStop state mon	1.18	250	Output current	1.1
1216	Digital input 4X mon	(*)	1024	Enable cmd mon	9.9	252	Output voltage	1.2
1218	Digital input 5X mon	(*)	1026	Start cmd mon	9.10	254	Output frequency	1.3
1220	Digital input 6X mon	(*)	1028	FastStop cmd mon	9.11	280	Torque current ref	1.9
1222	Digital input 7X mon	(*)	4708	Alm dig out mon 1	(*)	282	Magnet current ref	1.10
1224	Digital input 8X mon	(*)	4710	Alm dig out mon 2	(*)	284	Torque current	1.11
1226	Digital input 9X mon	(*)	4712	Alm dig out mon 3	(*)	286	Magnet current	1.12
1228	Digital input 10X mon	(*)	4714	Alm dig out mon 4	(*)	2360	Torque climPos Inuse	18.5
1230	Digital input 11X mon	(*)	362	Drive overload trip	(*)	2362	Torque climNeg Inuse	18.6
1232	Digital input 12X mon	(*)	3214	Motor overload trip	(*)	2386	Torque ref	18.10
4454	Bit0 decomp mon	20.6.3	3262	Bres overload trip	(*)	2388	Torque ref nofilter	(*)
4456	Bit1 decomp mon	20.6.4	366	Drive overload 80%	(*)	270	DC link voltage	1.7
4458	Bit2 decomp mon	20.6.5	4454	Bit0 decomp mon	20.6.3	2162	Encoder position	15.18
4460	Bit3 decomp mon	20.6.6	4456	Bit1 decomp mon	20.6.4	2154	Virtual position	23.2.2
4462	Bit4 decomp mon	20.6.7	4458	Bit2 decomp mon	20.6.5	2156	Revolutions	23.2.3
4464	Bit5 decomp mon	20.6.8	4460	Bit3 decomp mon	20.6.6	3104	Inertia comp mon	19.1.3
4466	Bit6 decomp mon	20.6.9	4462	Bit4 decomp mon	20.6.7	1600	Analog input 1X mon	12.1
4468	Bit7 decomp mon	20.6.10	4464	Bit5 decomp mon	20.6.8	1650	Analog input 2X mon	12.12
4470	Bit8 decomp mon	20.6.11	4466	Bit6 decomp mon	20.6.9	368	Drive overload accum	1.14
4472	Bit9 decomp mon	20.6.12	4468	Bit7 decomp mon	20.6.10	3212	Motor overload accum	1.13
4474	Bit10 decomp mon	20.6.13	4470	Bit8 decomp mon	20.6.11	3260	Bres overload accum	1.15
4476	Bit11 decomp mon	20.6.14	4472	Bit9 decomp mon	20.6.12	272	Heatsink temperature	1.8
4478	Bit12 decomp mon	20.6.15	4474	Bit10 decomp mon	20.6.13	1060	Sequencer status	(*)
4480	Bit13 decomp mon	20.6.16	4476	Bit11 decomp mon	20.6.14	4432	Word comp mon	20.5.17
4482	Bit14 decomp mon	20.6.17	4478	Bit12 decomp mon	20.6.15	6372	DS417 status word	(*)
4484	Bit15 decomp mon	20.6.18	4480	Bit13 decomp mon	20.6.16	4024	Fieldbus M->S1 mon	20.3.3
3700	Lift enable	19.6.1	4482	Bit14 decomp mon	20.6.17	4034	Fieldbus M->S2 mon	20.3.7
3702	Run cont mon	19.6.2	4484	Bit15 decomp mon	20.6.18	4044	Fieldbus M->S3 mon	20.3.11
3704	Up cont mon	19.6.3	3700	Lift enable	19.6.1	4054	Fieldbus M->S4 mon	20.3.15
3706	Down cont mon	19.6.4	3702	Run cont mon	19.6.2	4064	Fieldbus M->S5 mon	20.3.19
3708	Brake cont mon	19.6.5	3704	Up cont mon	19.6.3	4074	Fieldbus M->S6 mon	20.3.23
3710	Lift dc brake	19.6.6	3706	Down cont mon	19.6.4	4084	Fieldbus M->S7 mon	20.3.27
3712	Brake 2 mon	19.6.7	3708	Brake cont mon	19.6.5	4094	Fieldbus M->S8 mon	20.3.31
3714	Door open mon	19.6.8	3710	Lift dc brake	19.6.6	4104	Fieldbus M->S9 mon	20.3.35
3716	Lift start	19.6.9	3712	Brake 2 mon	19.6.7	4114	Fieldbus M->S10 mon	20.3.39
3718	Pad 10	19.6.10	3714	Door open mon	19.6.8	4124	Fieldbus M->S11 mon	20.3.43
3720	Lift status word	19.6.11	3716	Lift start	19.6.9	4134	Fieldbus M->S12 mon	20.3.47
3722	Pad 12	19.6.12	3718	Pad 10	19.6.10	4144	Fieldbus M->S13 mon	20.3.51
3724	Pad 13	19.6.13	3720	Lift status word	19.6.11	4154	Fieldbus M->S14 mon	20.3.55
3726	Ramp down limit	19.6.14	3722	Pad 12	19.6.12	4164	Fieldbus M->S15 mon	20.3.59
3728	PAD 15	19.6.15	3724	Pad 13	19.6.13	4174	Fieldbus M->S16 mon	20.3.63
3730	Lift wdec input	19.6.16	3726	Ramp down limit	19.6.14	3700	Lift enable	19.6.1
3676	Compare output	19.5.8	3728	PAD 15	19.6.15	3702	Run cont mon	19.6.2
			3730	Lift wdec input	19.6.16	3704	Up cont mon	19.6.3
			6006	Current limit state	(*)	3706	Down cont mon	19.6.4
			764	Ramp acc state	(*)	3708	Brake cont mon	19.6.5
			766	Ramp dec state	(*)	3710	Lift dc brake	19.6.6
			4780	Alarm PLC	(*)	3712	Brake 2 mon	19.6.7
			3676	Compare output	19.5.8	3714	Door open mon	19.6.8
						3716	Lift start	19.6.9
						3718	Pad 10	19.6.10
						3720	Lift status word	19.6.11
						3722	Pad 12	19.6.12
						3724	Pad 13	19.6.13
						3726	Ramp down limit	19.6.14
						3728	PAD 15	19.6.15
						3730	Lift wdec input	19.6.16
						4770	First alarm	(*)
						1200	Digital input X mon	1.19
						5008	Test gen out	23.1.5
L_DIGSEL3								
XXXX ⁽²⁾			(2) the XXXX parameter changes according to the src parameter used:					
6000	Null	(*)	1014	Local/remote src				
1218	Digital input 5X mon	(*)	(2) = 1012 Dig local/remote	(*)				
1220	Digital input 6X mon	(*)	L_FBS2M					
1222	Digital input 7X mon	(*)	XXXX ⁽³⁾					
1224	Digital input 8X mon	(*)	6000	Null	(*)			
1226	Digital input 9X mon	(*)						
1228	Digital input 10X mon	(*)						
1230	Digital input 11X mon	(*)						
1232	Digital input 12X mon	(*)						
1062	Drive OK	(*)						

PAR	Description	Menu
⁽³⁾ the XXXX parameter changes according to the src parameter used:		
6340	DS417 cw src	
⁽³⁾ = 4024	Fieldbus M->S1 mon	20.3.3
6380	DS417 key src	
⁽³⁾ = 4024	Fieldbus M->S1 mon	20.3.3

L_LIM

6000	Null	(*)
1600	Analog input 1X mon	12.1
1650	Analog input 2X mon	12.12
4024	Fieldbus M->S1 mon	20.3.3
4034	Fieldbus M->S2 mon	20.3.7
4044	Fieldbus M->S3 mon	20.3.11
4054	Fieldbus M->S4 mon	20.3.15
4064	Fieldbus M->S5 mon	20.3.19
4074	Fieldbus M->S6 mon	20.3.23
4084	Fieldbus M->S7 mon	20.3.27
4094	Fieldbus M->S8 mon	20.3.31
4104	Fieldbus M->S9 mon	20.3.35
4114	Fieldbus M->S10 mon	20.3.39
4124	Fieldbus M->S11 mon	20.3.43
4134	Fieldbus M->S12 mon	20.3.47
4144	Fieldbus M->S13 mon	20.3.51
4154	Fieldbus M->S14 mon	20.3.55
4164	Fieldbus M->S15 mon	20.3.59
4174	Fieldbus M->S16 mon	20.3.63
3700	Lift enable	19.6.1
3702	Run cont mon	19.6.2
3704	Up cont mon	19.6.3
3706	Down cont mon	19.6.4
3708	Brake cont mon	19.6.5
3710	Lift dc brake	19.6.6
3712	Brake 2 mon	19.6.7
3714	Door open mon	19.6.8
3716	Lift start	19.6.9
3718	Pad 10	19.6.10
3720	Lift status word	19.6.11
3722	Pad 12	19.6.12
3724	Pad 13	19.6.13
3726	Ramp down limit	19.6.14
3728	PAD 15	19.6.15
3730	Lift wdec input	19.6.16
5008	Test gen out	23.1.5

L_MLTREF

XXXXX ⁽⁴⁾		
1600	Analog input 1X mon	12.1
1650	Analog input 2X mon	12.12
2150	Encoder speed	15.17
4024	Fieldbus M->S1 mon	20.3.3
4034	Fieldbus M->S2 mon	20.3.7
4044	Fieldbus M->S3 mon	20.3.11
4054	Fieldbus M->S4 mon	20.3.15
4064	Fieldbus M->S5 mon	20.3.19
4074	Fieldbus M->S6 mon	20.3.23
4084	Fieldbus M->S7 mon	20.3.27
4094	Fieldbus M->S8 mon	20.3.31
4104	Fieldbus M->S9 mon	20.3.35
4114	Fieldbus M->S10 mon	20.3.39
4124	Fieldbus M->S11 mon	20.3.43
4134	Fieldbus M->S12 mon	20.3.47
4144	Fieldbus M->S13 mon	20.3.51

PAR	Description	Menu
4154	Fieldbus M->S14 mon	20.3.55
4164	Fieldbus M->S15 mon	20.3.59
4174	Fieldbus M->S16 mon	20.3.63
3700	Lift enable	19.6.1
3702	Run cont mon	19.6.2
3704	Up cont mon	19.6.3
3706	Down cont mon	19.6.4
3708	Brake cont mon	19.6.5
3710	Lift dc brake	19.6.6
3712	Brake 2 mon	19.6.7
3714	Door open mon	19.6.8
3716	Lift start	19.6.9
3718	Pad 10	19.6.10
3720	Lift status word	19.6.11
3722	Pad 12	19.6.12
3724	Pad 13	19.6.13
3726	Ramp down limit	19.6.14
3728	PAD 15	19.6.15
3730	Lift wdec input	19.6.16
5008	Test gen out	23.1.5

⁽⁴⁾ the XXXX parameter changes according to the src parameter used:

610	Ramp ref 1 src	
⁽⁴⁾ = 600	Dig ramp ref 1	6.1
612	Ramp ref 2 src	
⁽⁴⁾ = 602	Dig ramp ref 2	6.2
650	Ramp ref 3 src	
⁽⁴⁾ = 640	Dig ramp ref 3	6.8
652	Ramp ref 4 src	
⁽⁴⁾ = 642	Dig ramp ref 4	6.9

L_REF

626	Ramp ref out mon	(*)
664	Speed setpoint	1.5
262	Motor speed nofilter	(*)
2150	Encoder speed	15.17
1600	Analog input 1X mon	12.1
1650	Analog input 2X mon	12.12
4024	Fieldbus M->S1 mon	20.3.3
4034	Fieldbus M->S2 mon	20.3.7
4044	Fieldbus M->S3 mon	20.3.11
4054	Fieldbus M->S4 mon	20.3.15
4064	Fieldbus M->S5 mon	20.3.19
4074	Fieldbus M->S6 mon	20.3.23
4084	Fieldbus M->S7 mon	20.3.27
4094	Fieldbus M->S8 mon	20.3.31
4104	Fieldbus M->S9 mon	20.3.35
4114	Fieldbus M->S10 mon	20.3.39
4124	Fieldbus M->S11 mon	20.3.43
4134	Fieldbus M->S12 mon	20.3.47
4144	Fieldbus M->S13 mon	20.3.51
4154	Fieldbus M->S14 mon	20.3.55
4164	Fieldbus M->S15 mon	20.3.59
4174	Fieldbus M->S16 mon	20.3.63
3700	Lift enable	19.6.1
3702	Run cont mon	19.6.2
3704	Up cont mon	19.6.3
3706	Down cont mon	19.6.4
3708	Brake cont mon	19.6.5
3710	Lift dc brake	19.6.6
3712	Brake 2 mon	19.6.7

PAR	Description	Menu
3714	Door open mon	19.6.8
3716	Lift start	19.6.9
3718	Pad 10	19.6.10
3720	Lift status word	19.6.11
3722	Pad 12	19.6.12
3724	Pad 13	19.6.13
3726	Ramp down limit	19.6.14
3728	PAD 15	19.6.15
3730	Lift wdec input	19.6.16
5008	Test gen out	23.1.5

L_SCOPE

6000	Null	(*)
------	------	-----

L_VREF

XXXXX ⁽⁵⁾		
1600	Analog input 1X mon	12.1
1650	Analog input 2X mon	12.12
4024	Fieldbus M->S1 mon	20.3.3
4034	Fieldbus M->S2 mon	20.3.7
4044	Fieldbus M->S3 mon	20.3.11
4054	Fieldbus M->S4 mon	20.3.15
4064	Fieldbus M->S5 mon	20.3.19
4074	Fieldbus M->S6 mon	20.3.23
4084	Fieldbus M->S7 mon	20.3.27
4094	Fieldbus M->S8 mon	20.3.31
4104	Fieldbus M->S9 mon	20.3.35
4114	Fieldbus M->S10 mon	20.3.39
4124	Fieldbus M->S11 mon	20.3.43
4134	Fieldbus M->S12 mon	20.3.47
4144	Fieldbus M->S13 mon	20.3.51
4154	Fieldbus M->S14 mon	20.3.55
4164	Fieldbus M->S15 mon	20.3.59
4174	Fieldbus M->S16 mon	20.3.63
3700	Lift enable	19.6.1
3702	Run cont mon	19.6.2
3704	Up cont mon	19.6.3
3706	Down cont mon	19.6.4
3708	Brake cont mon	19.6.5
3710	Lift dc brake	19.6.6
3712	Brake 2 mon	19.6.7
3714	Door open mon	19.6.8
3716	Lift start	19.6.9
3718	Pad 10	19.6.10
3720	Lift status word	19.6.11
3722	Pad 12	19.6.12
3724	Pad 13	19.6.13
3726	Ramp down limit	19.6.14
3728	PAD 15	19.6.15
3730	Lift wdec input	19.6.16
6000	Null	(*)
5008	Test gen out	23.1.5

⁽⁵⁾ the XXXX parameter changes according to the src parameter used:

2382	Torque ref 1 src	
⁽⁵⁾ = 2380	Dig torque ref 1	18.7

L_WDECMP

XXXXX ⁽⁶⁾		
6000	Null	(*)

PAR	Description	Menu	PAR	Description	Menu	PAR	Description	Menu
6002	One	(*)						
4432	Word comp mon	20.5.17						
4024	Fieldbus M->S1 mon	20.3.3						
4034	Fieldbus M->S2 mon	20.3.7						
4044	Fieldbus M->S3 mon	20.3.11						
4054	Fieldbus M->S4 mon	20.3.15						
4064	Fieldbus M->S5 mon	20.3.19						
4074	Fieldbus M->S6 mon	20.3.23						
4084	Fieldbus M->S7 mon	20.3.27						
4094	Fieldbus M->S8 mon	20.3.31						
4104	Fieldbus M->S9 mon	20.3.35						
4114	Fieldbus M->S10 mon	20.3.39						
4124	Fieldbus M->S11 mon	20.3.43						
4134	Fieldbus M->S12 mon	20.3.47						
4144	Fieldbus M->S13 mon	20.3.51						
4154	Fieldbus M->S14 mon	20.3.55						
4164	Fieldbus M->S15 mon	20.3.59						
4174	Fieldbus M->S16 mon	20.3.63						
3700	Lift enable	19.6.1						
3702	Run cont mon	19.6.2						
3704	Up cont mon	19.6.3						
3706	Down cont mon	19.6.4						
3708	Brake cont mon	19.6.5						
3710	Lift dc brake	19.6.6						
3712	Brake 2 mon	19.6.7						
3714	Door open mon	19.6.8						
3716	Lift start	19.6.9						
3718	Pad 10	19.6.10						
3720	Lift status word	19.6.11						
3722	Pad 12	19.6.12						
3724	Pad 13	19.6.13						
3726	Ramp down limit	19.6.14						
3728	PAD 15	19.6.15						
3730	Lift wdec input	19.6.16						

⁽⁶⁾ the XXXX parameter changes according to the src parameter use:

4452 Word decomp src
⁽⁶⁾ = 4450 Dig word decomp 20.6.1

(*)
 Parameter not shown on the keypad. For information see the "PARAMETERS INCLUDED IN SELECTION LISTS BUT NOT SHOWN ON THE KEYPAD" section.

D - Block Diagrams

System diagram index (Syn.)

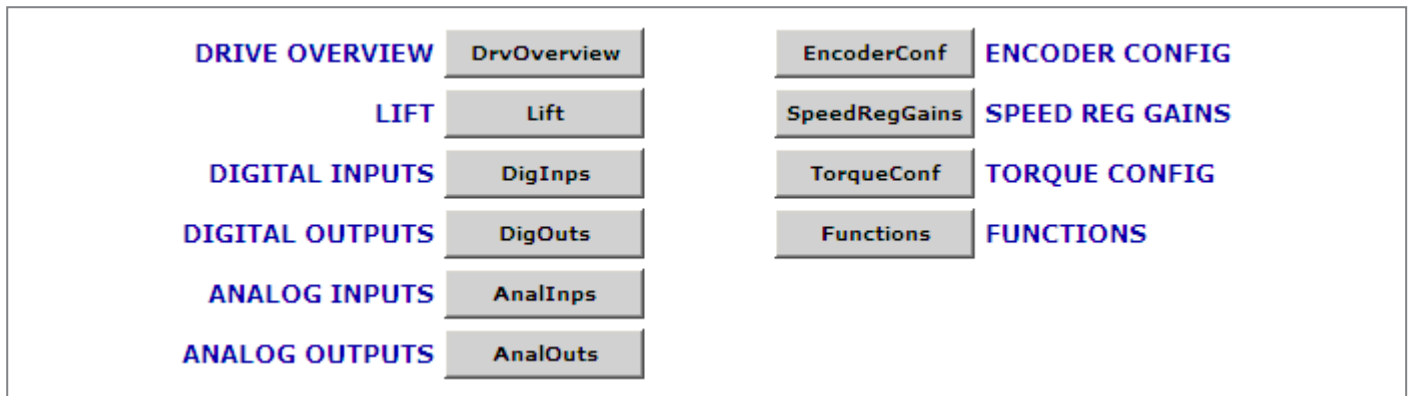

Drive overview (DrvOverview)

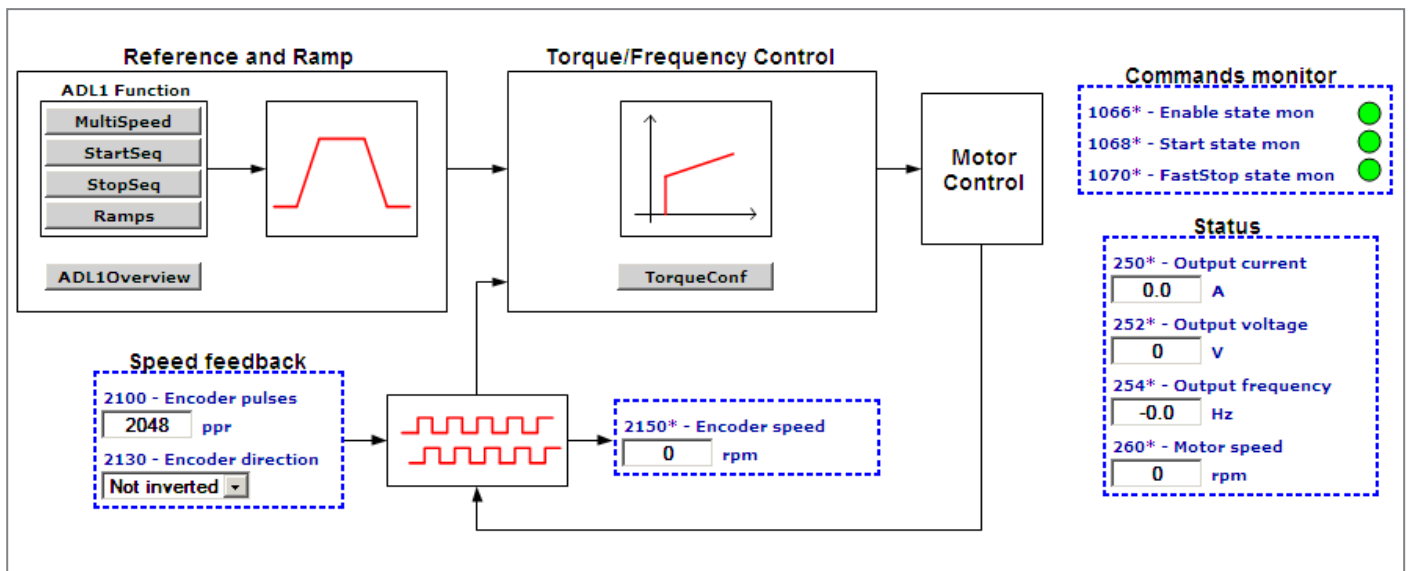

ADL1 application index (ADL1FuncIndex)

ADL1 OVERVIEW	ADL1Overview
MULTISPEED	MultiSpeed
START SEQUENCES	StartSeq
STOP SEQUENCES	StopSeq
RAMPS	Ramps
PRE TORQUE	PreTorque

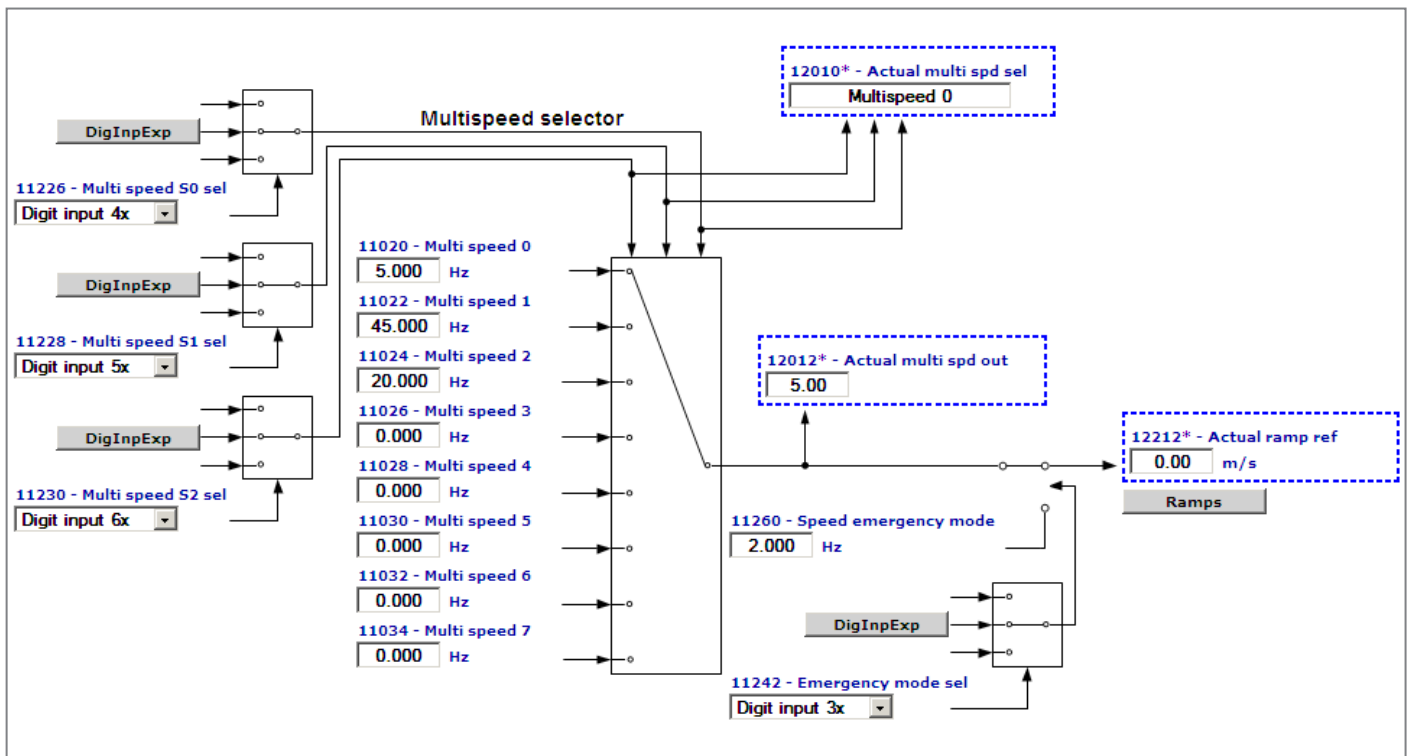
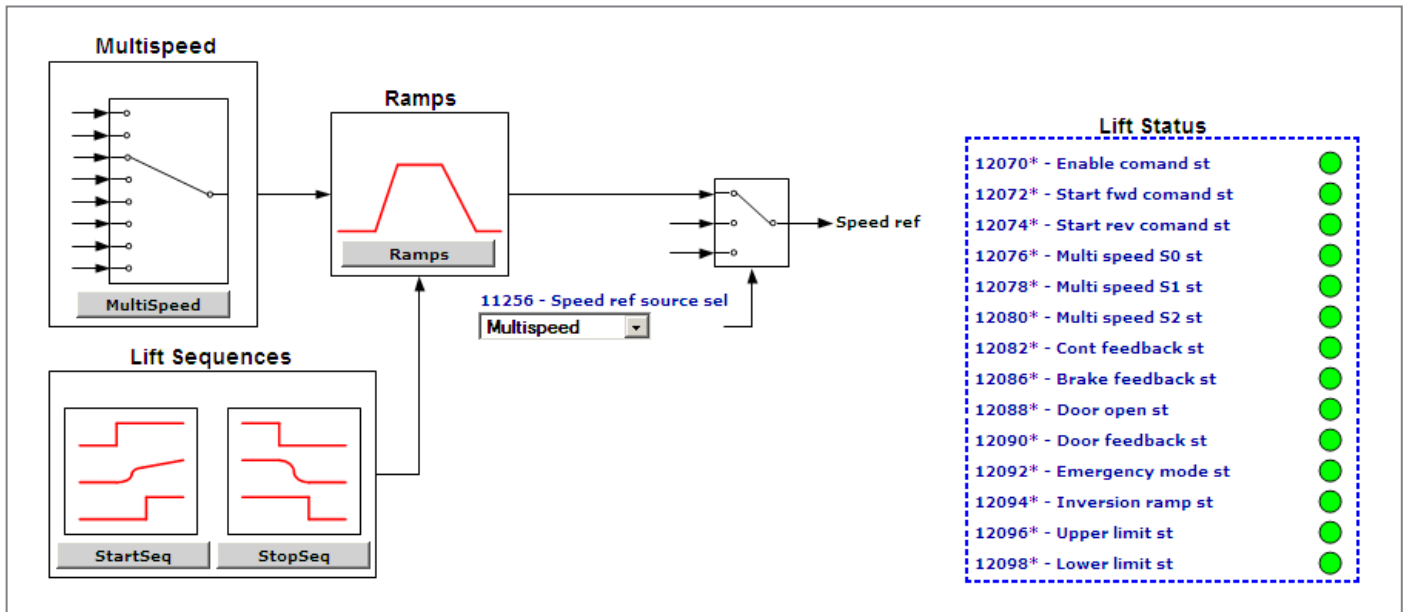

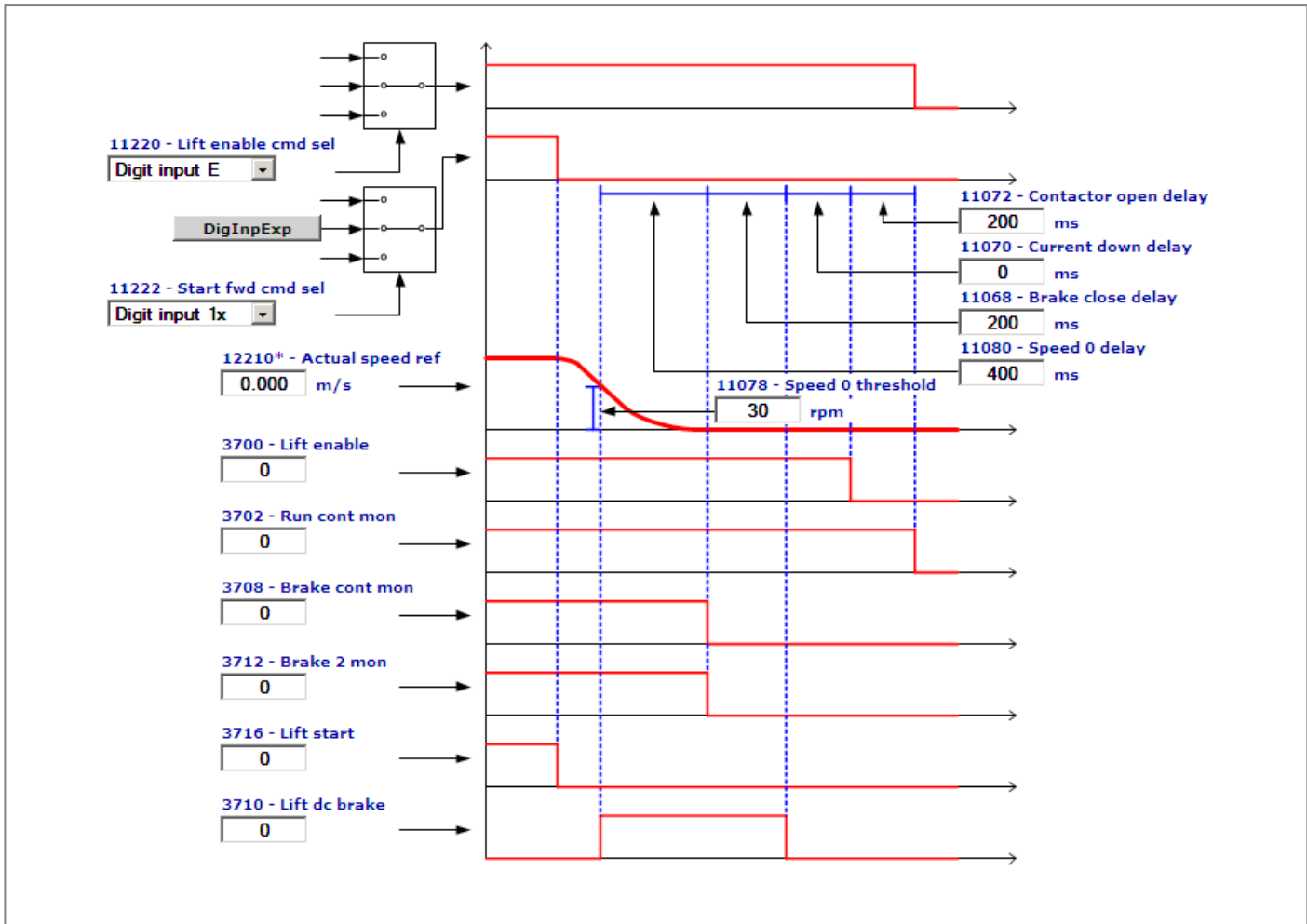
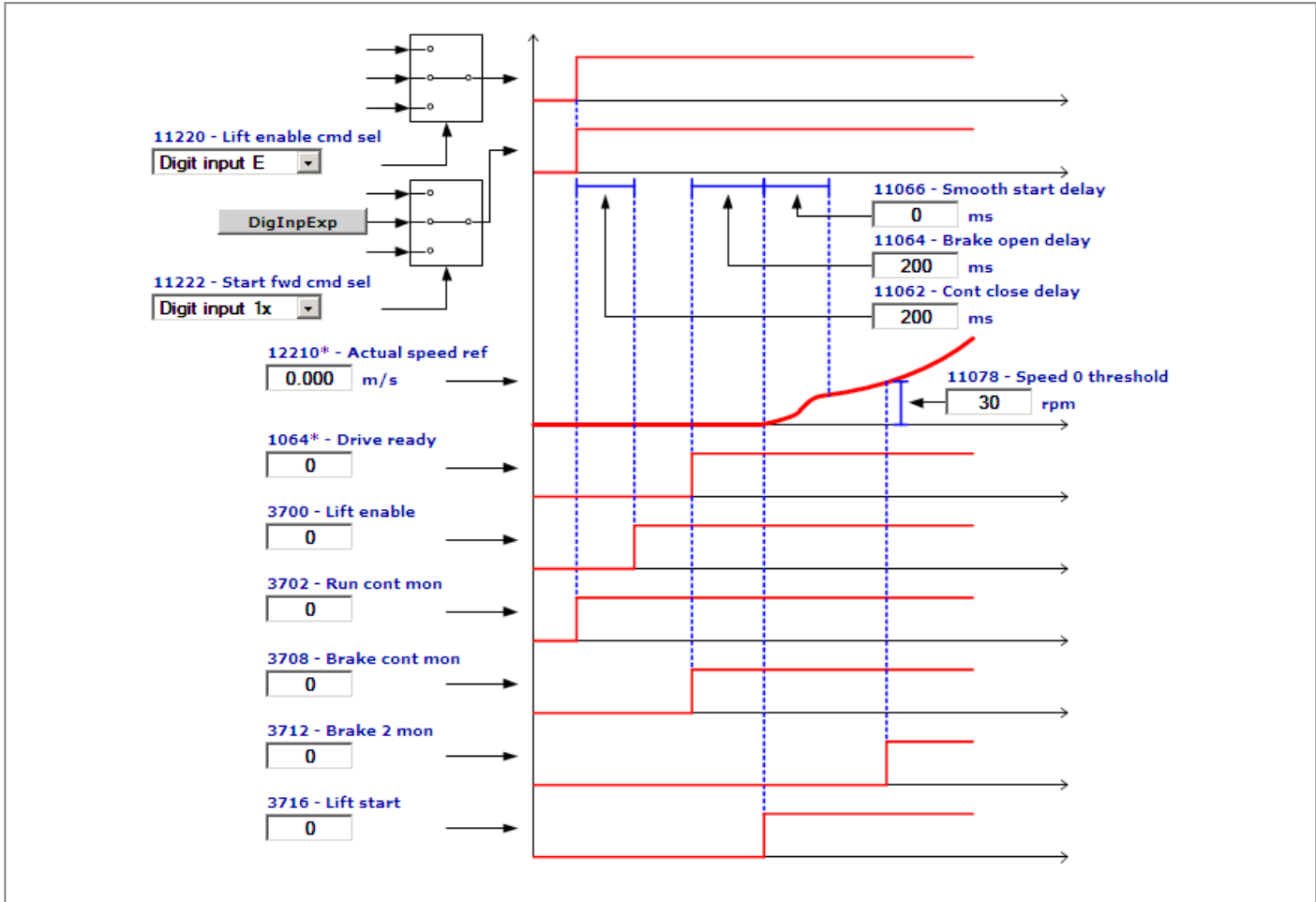

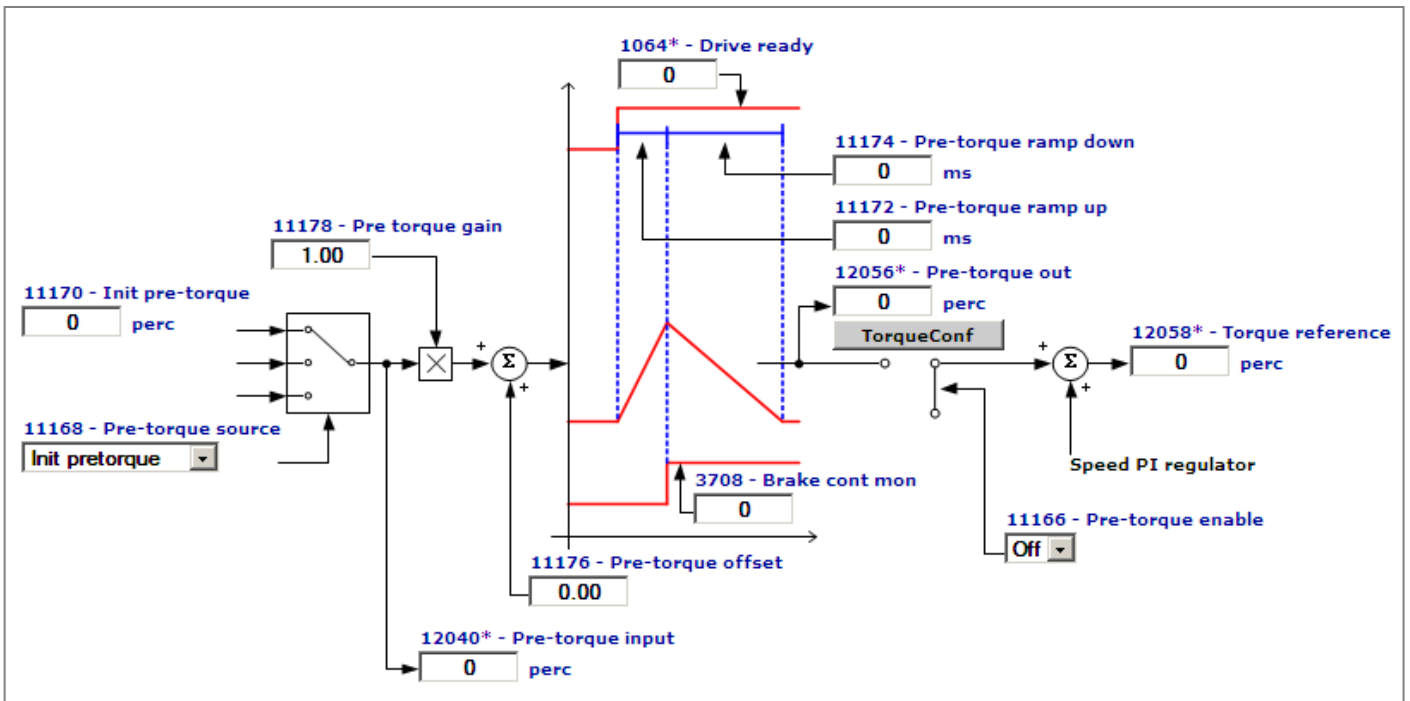
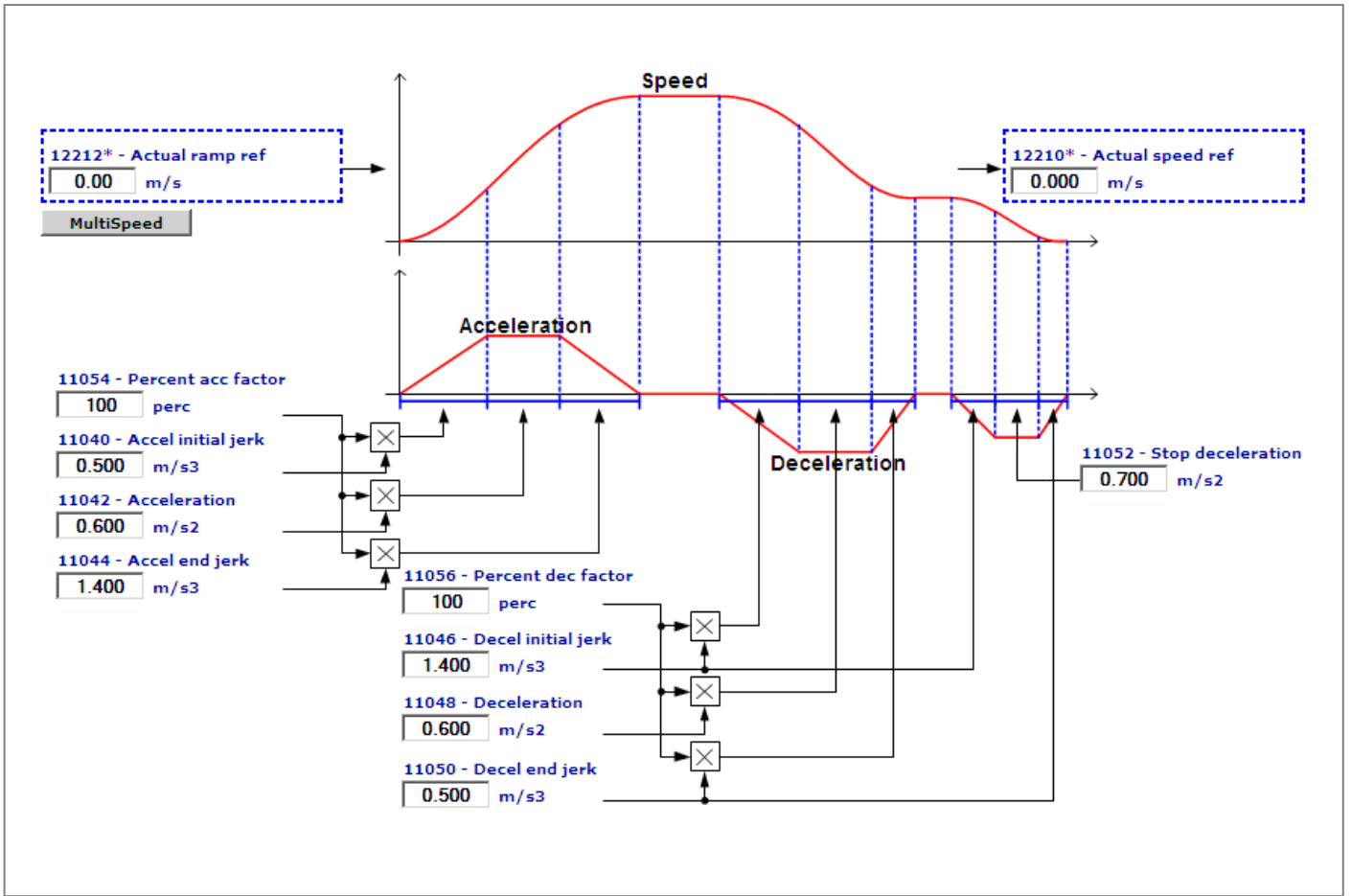

Expansion card digital inputs (DigImpExp)

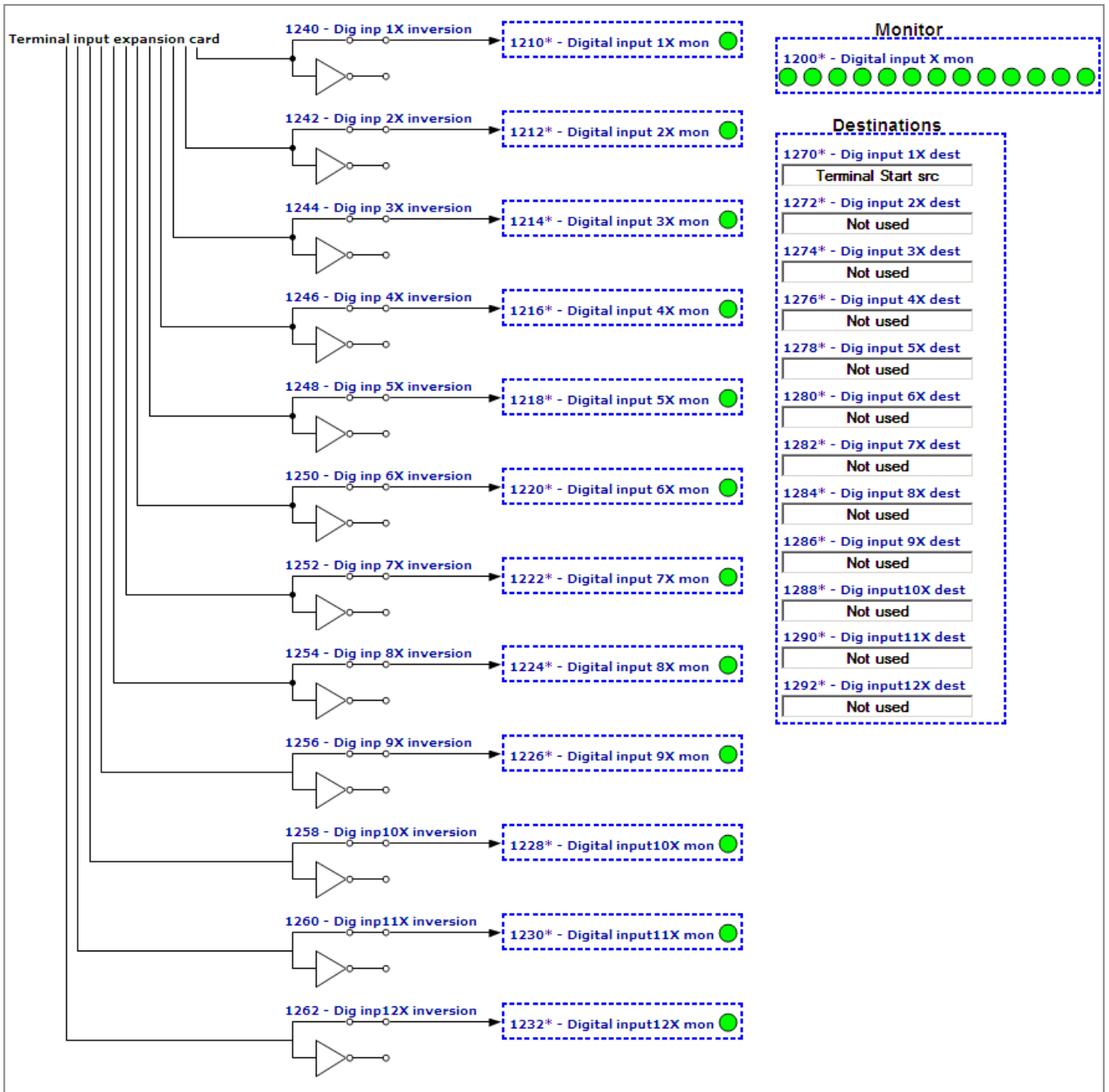

Expansion card digital outputs (DigOutExp)

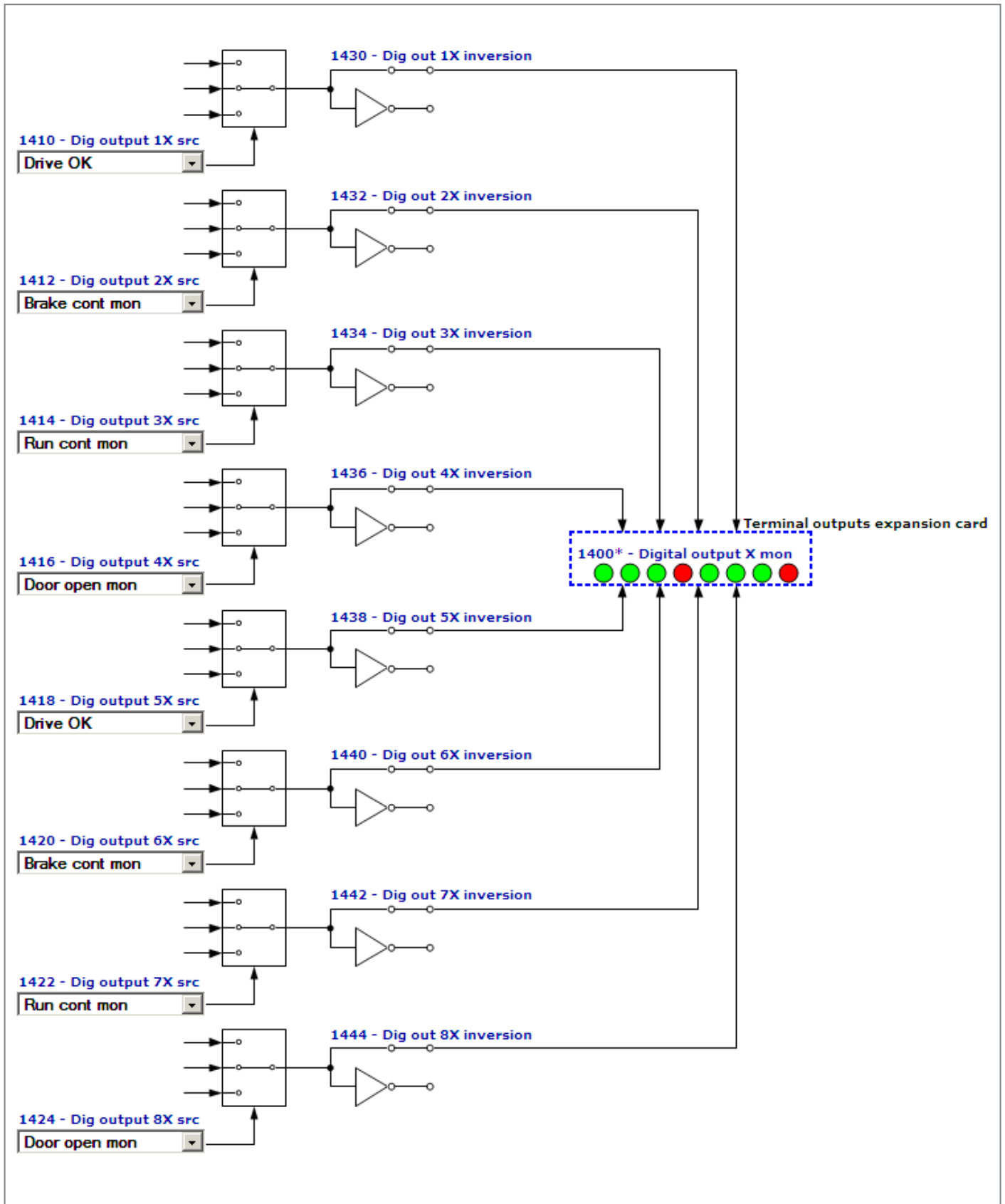

Analog input (AnInpExp)

ANALOG INPUT 1 EXPANSION CARD

AnInp1Exp

ANALOG INPUT 2 EXPANSION CARD

AnInp2Exp

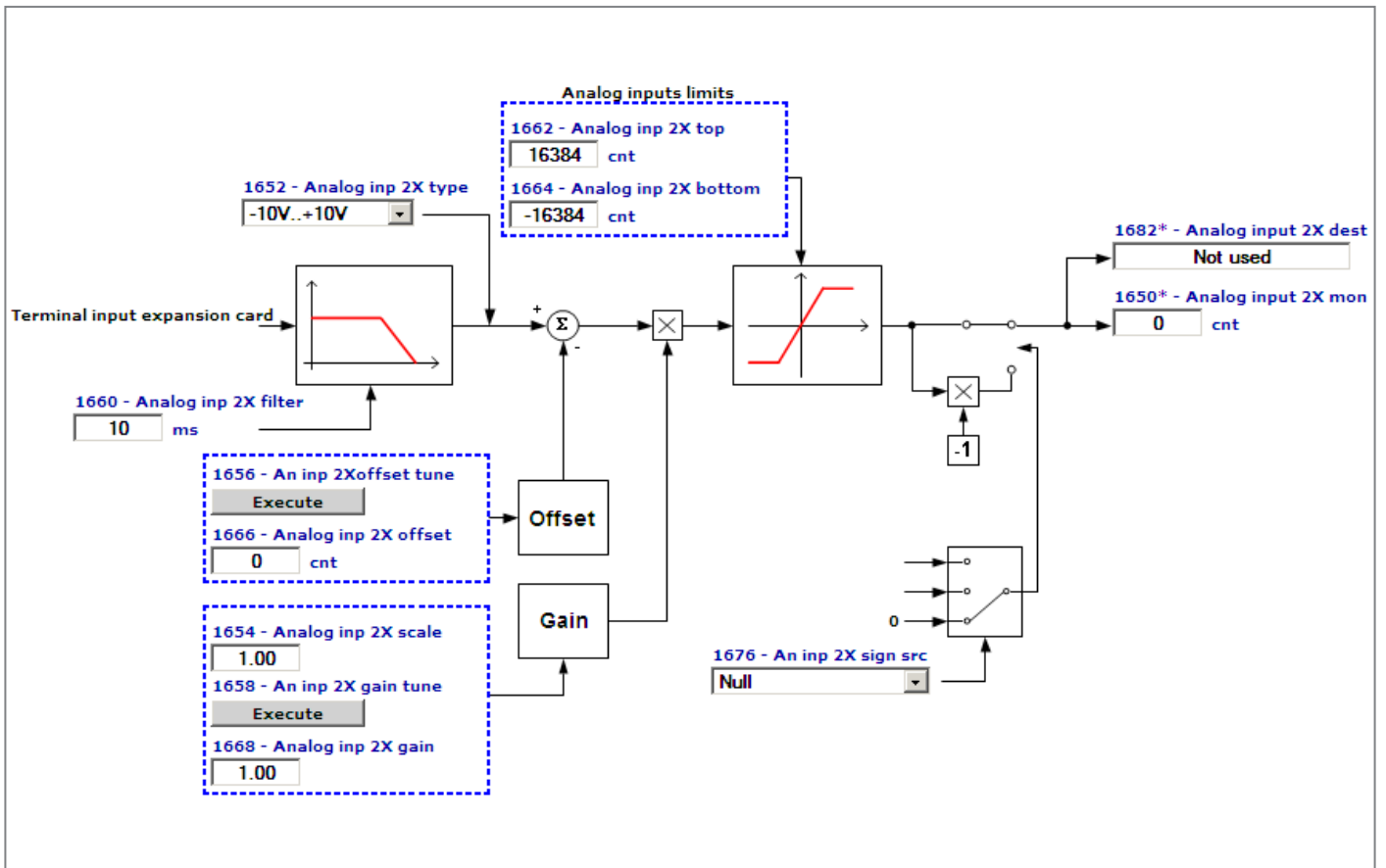
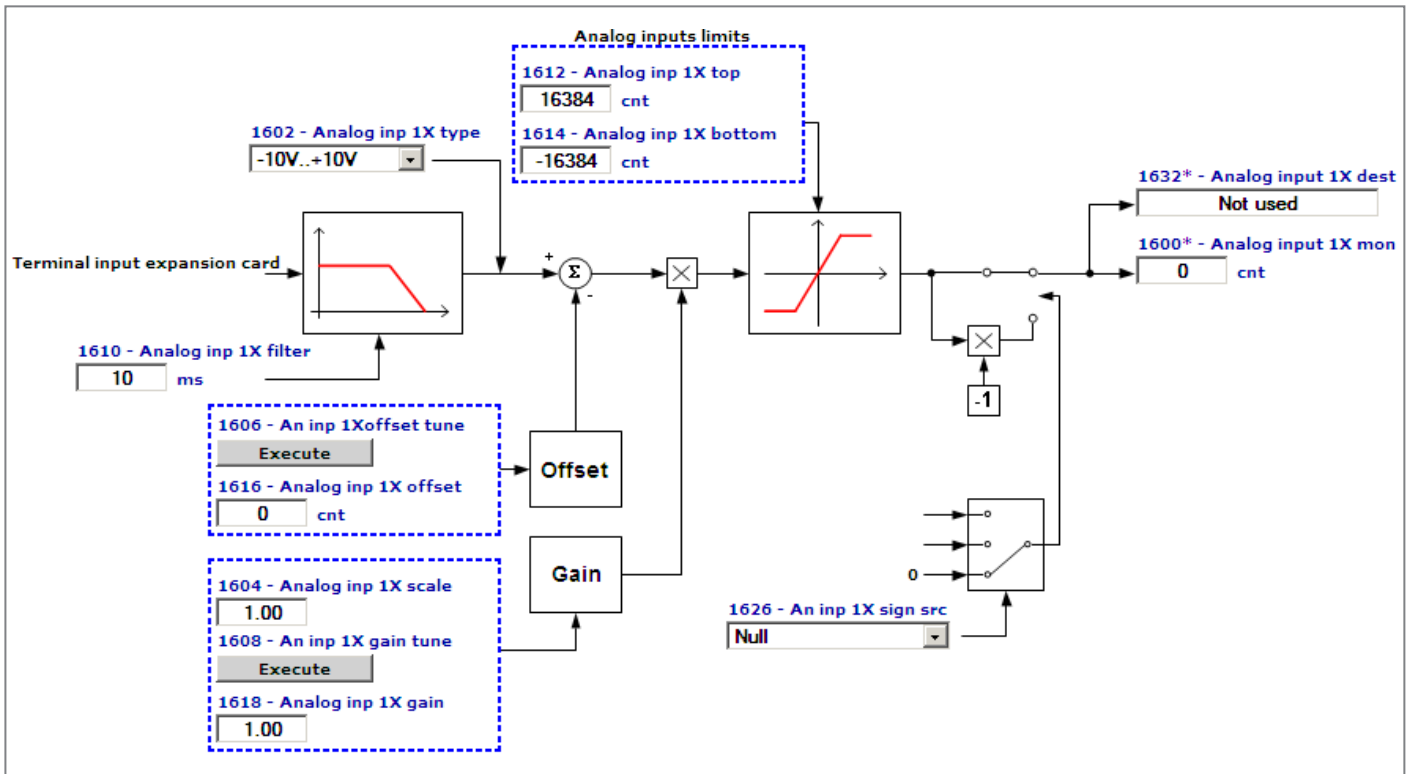

Analog output (AnOut)

ANALOG OUTPUT 1 EXPANSION CARD

AnOut1Exp

ANALOG OUTPUT 2 EXPANSION CARD

AnOut2Exp

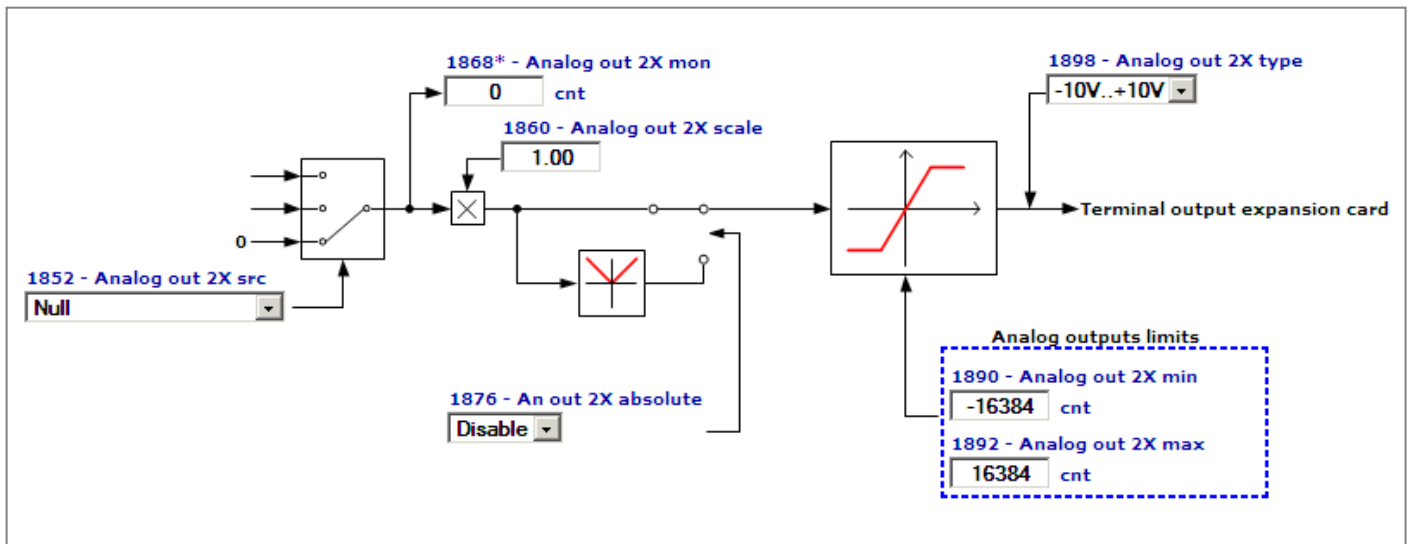
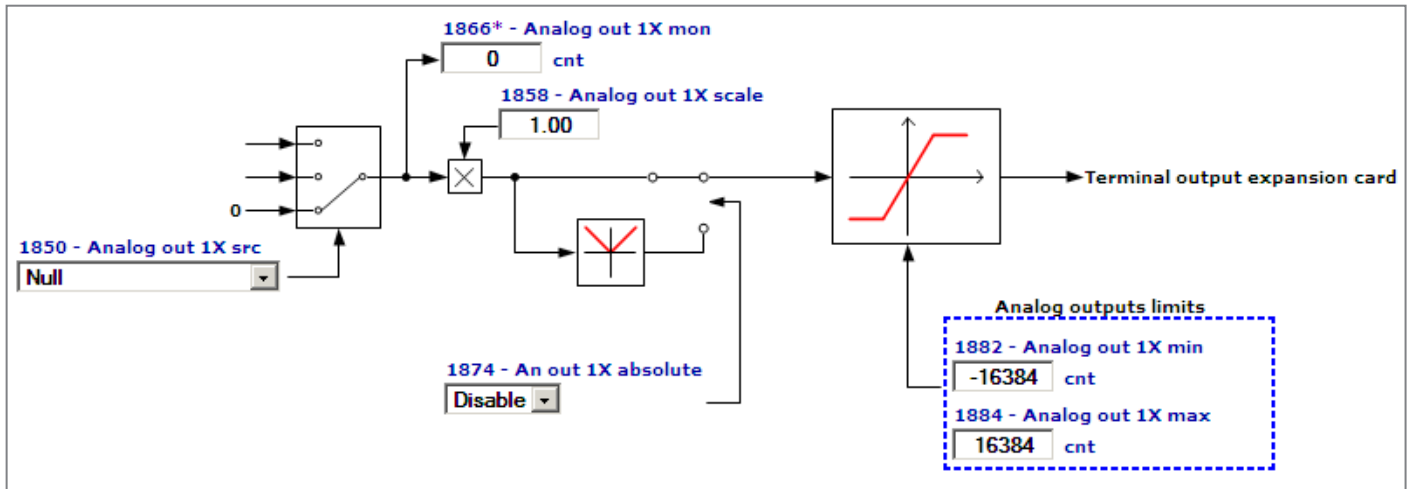

Encoder config

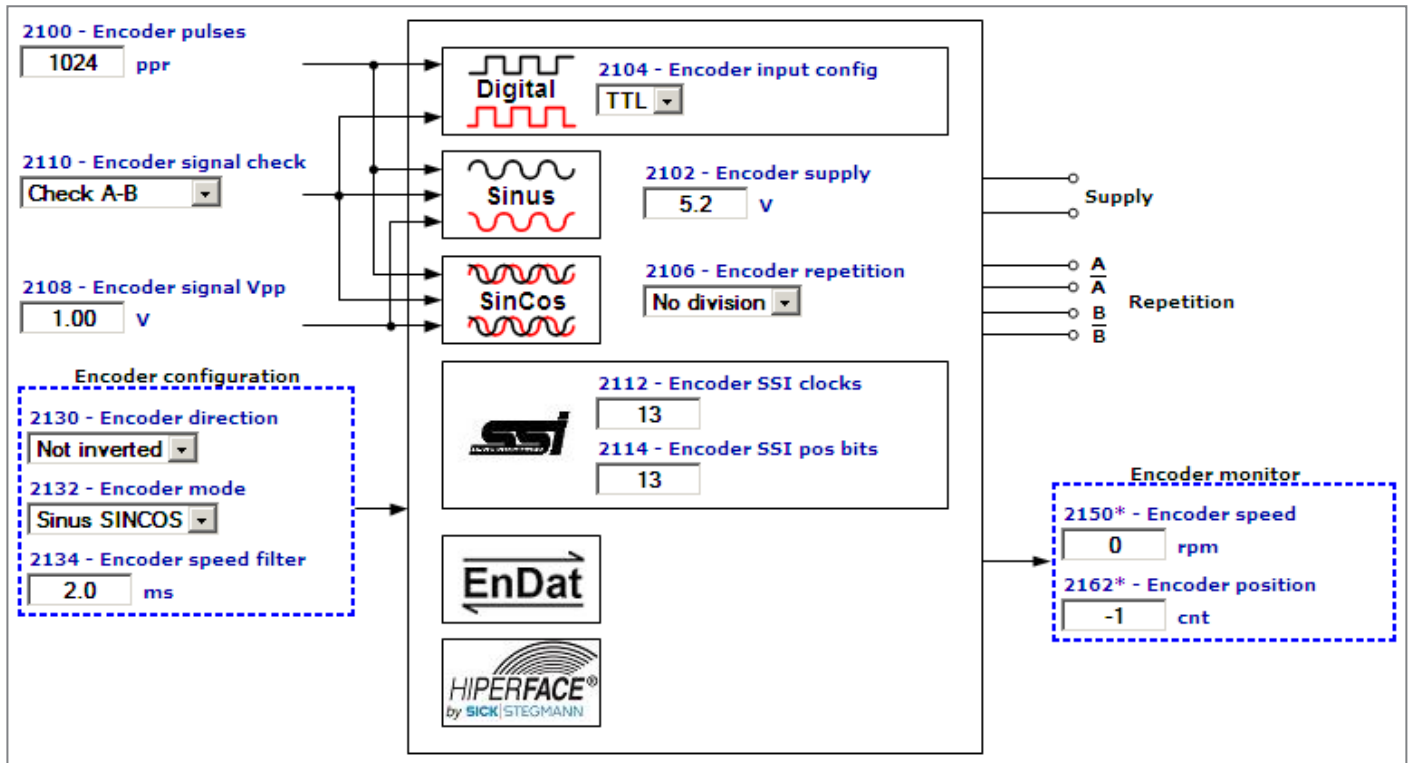

Functions

- INERTIA COMP
- MOTOR OVERLOAD
- BRES OVERLOAD
- DOUBLE PAR SET
- COMPARE

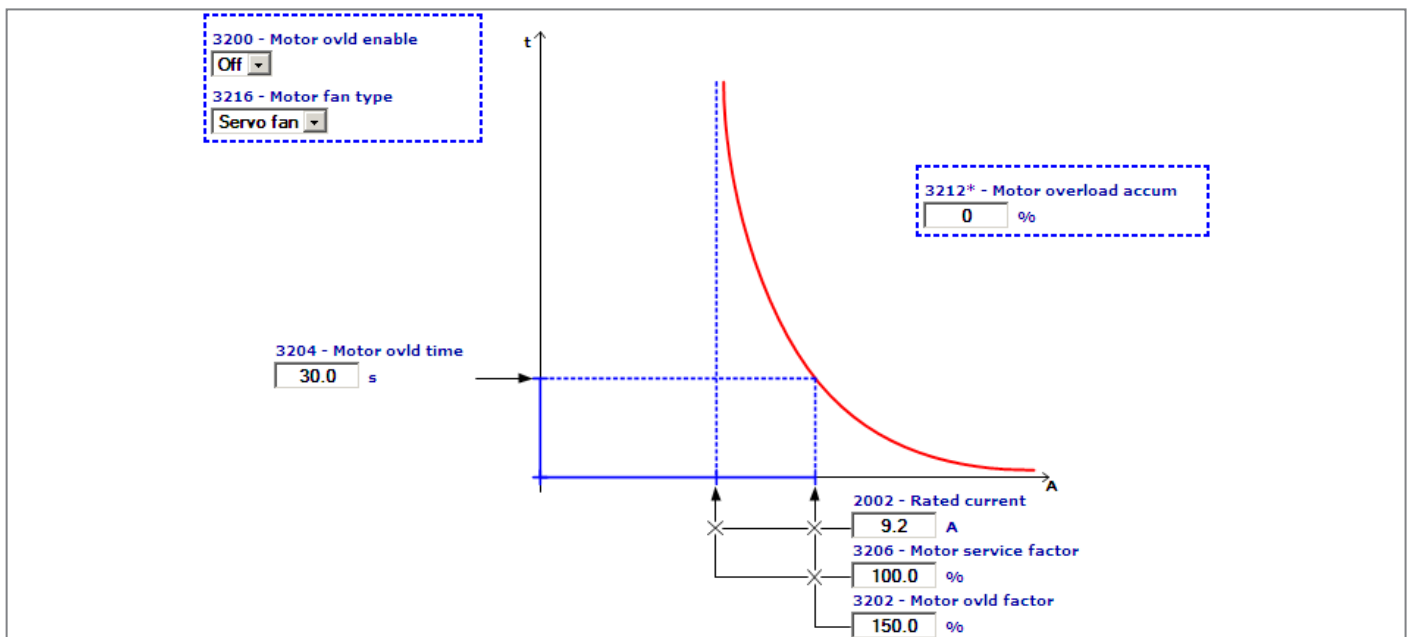
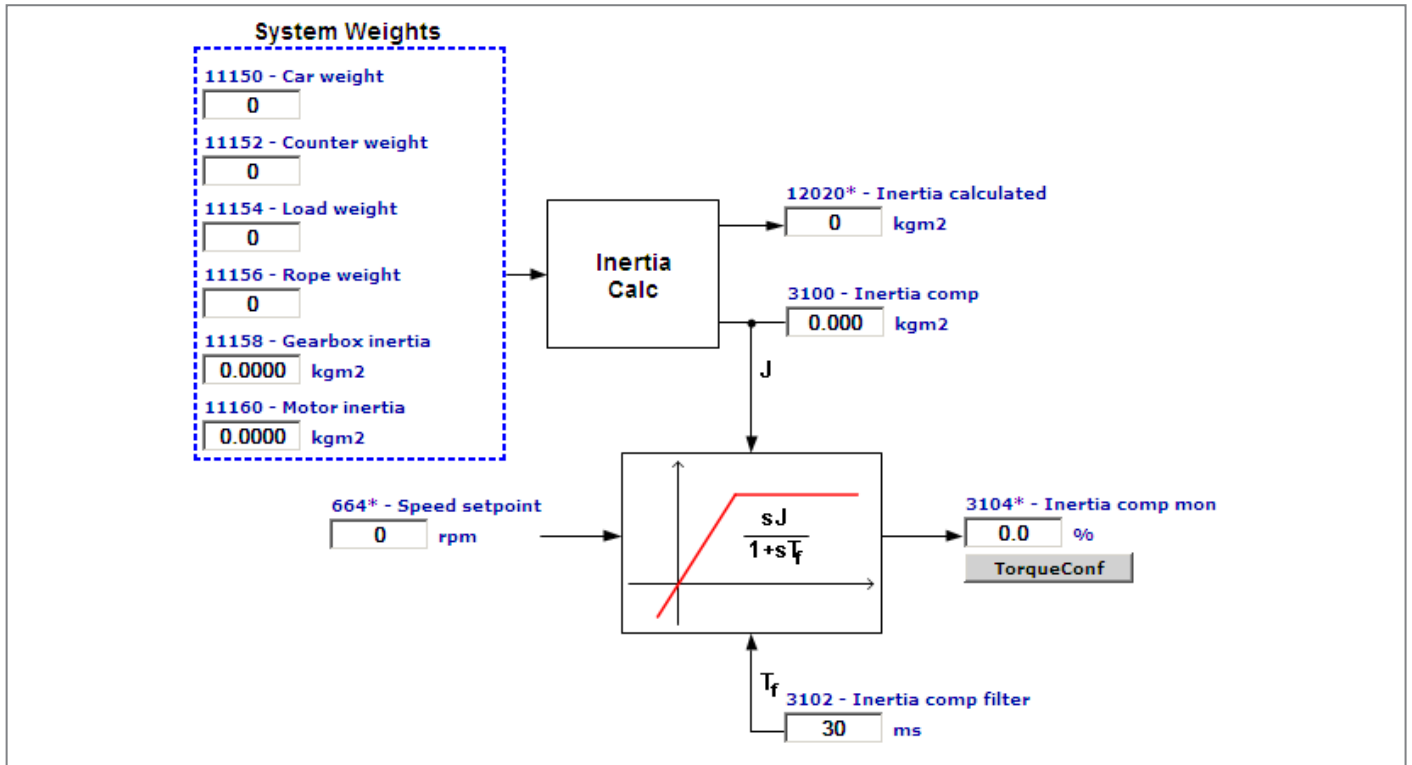

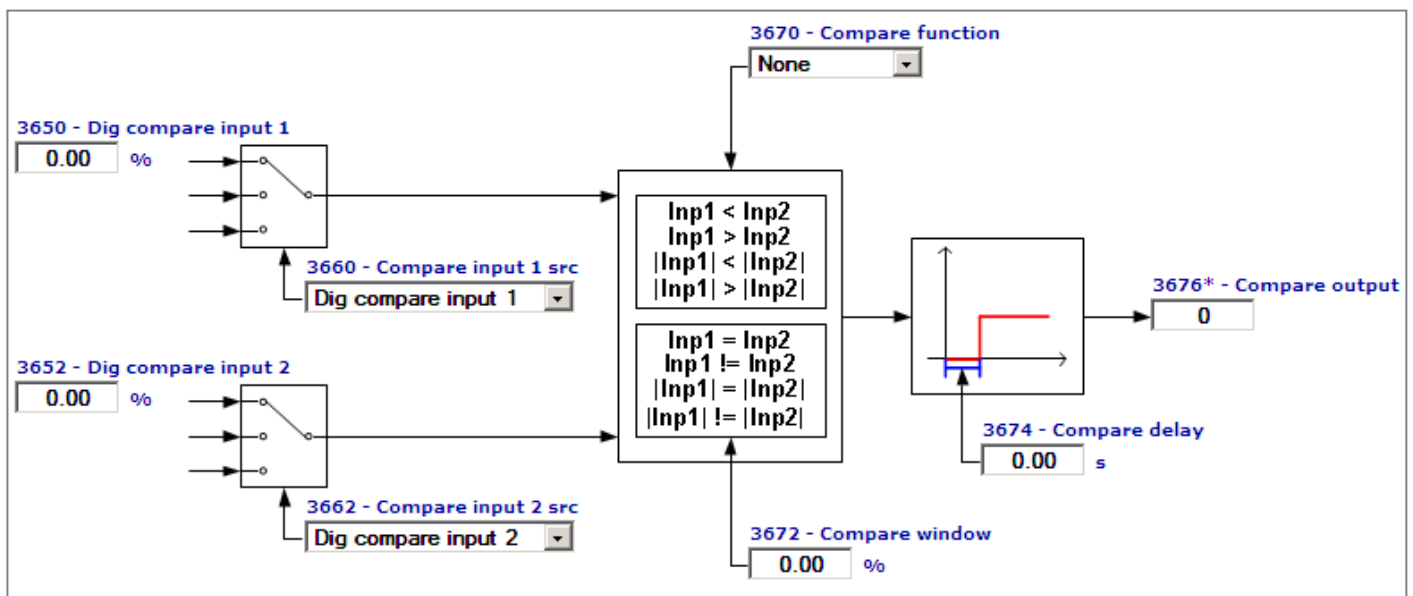
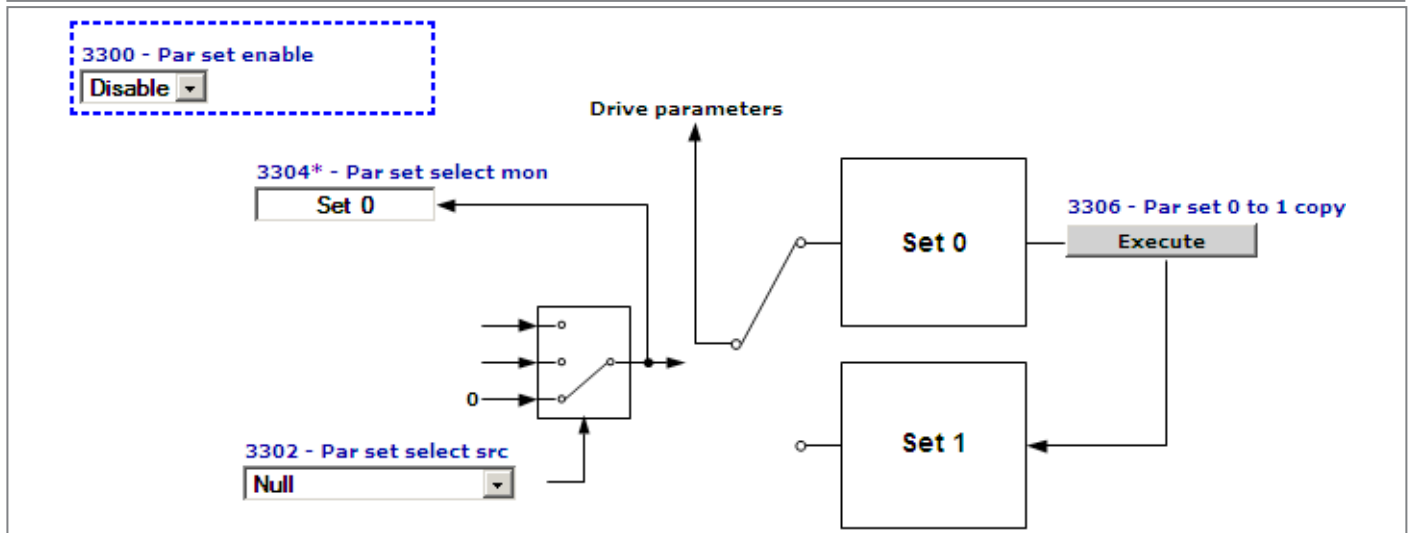
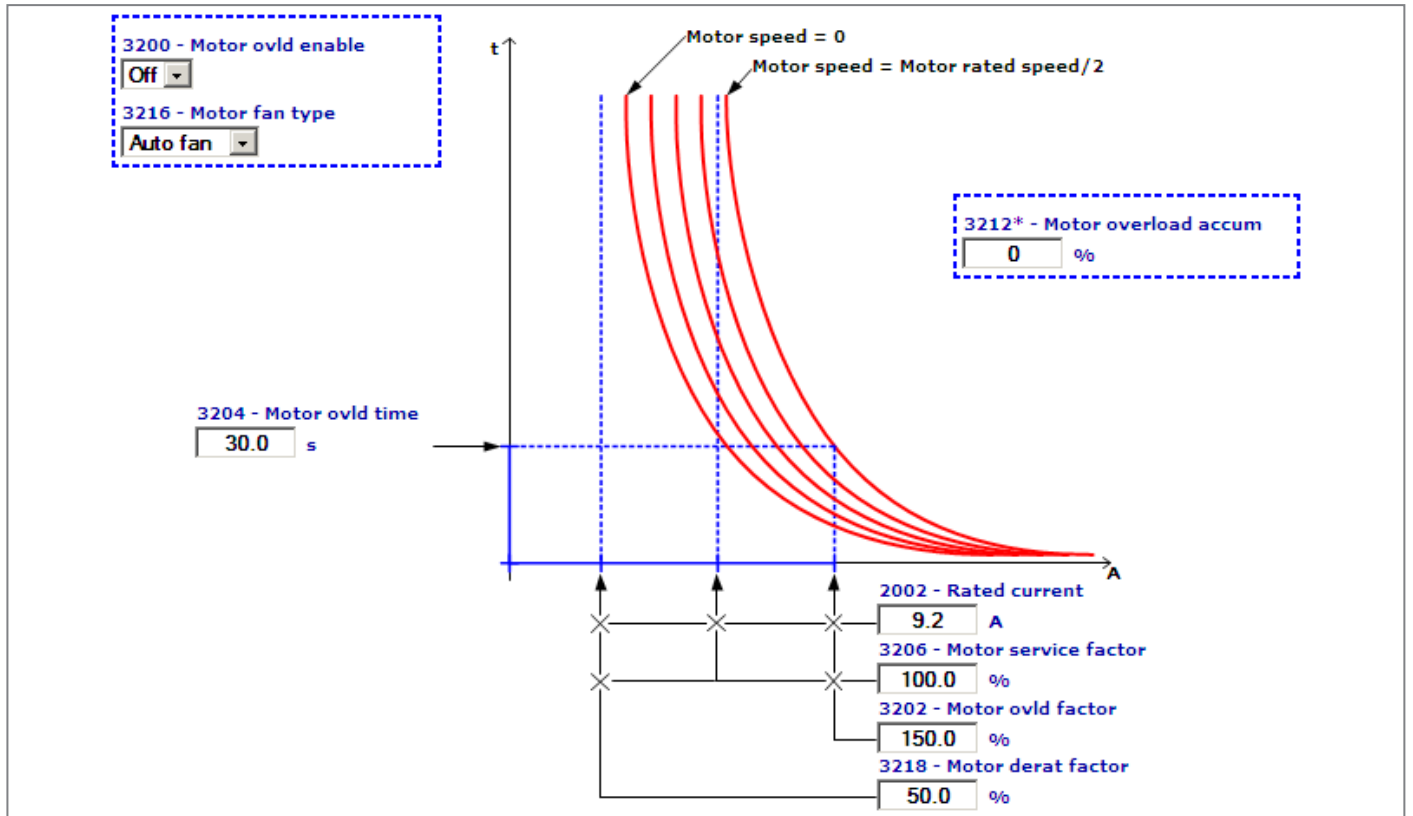

Torque control (TorqueCtrl)

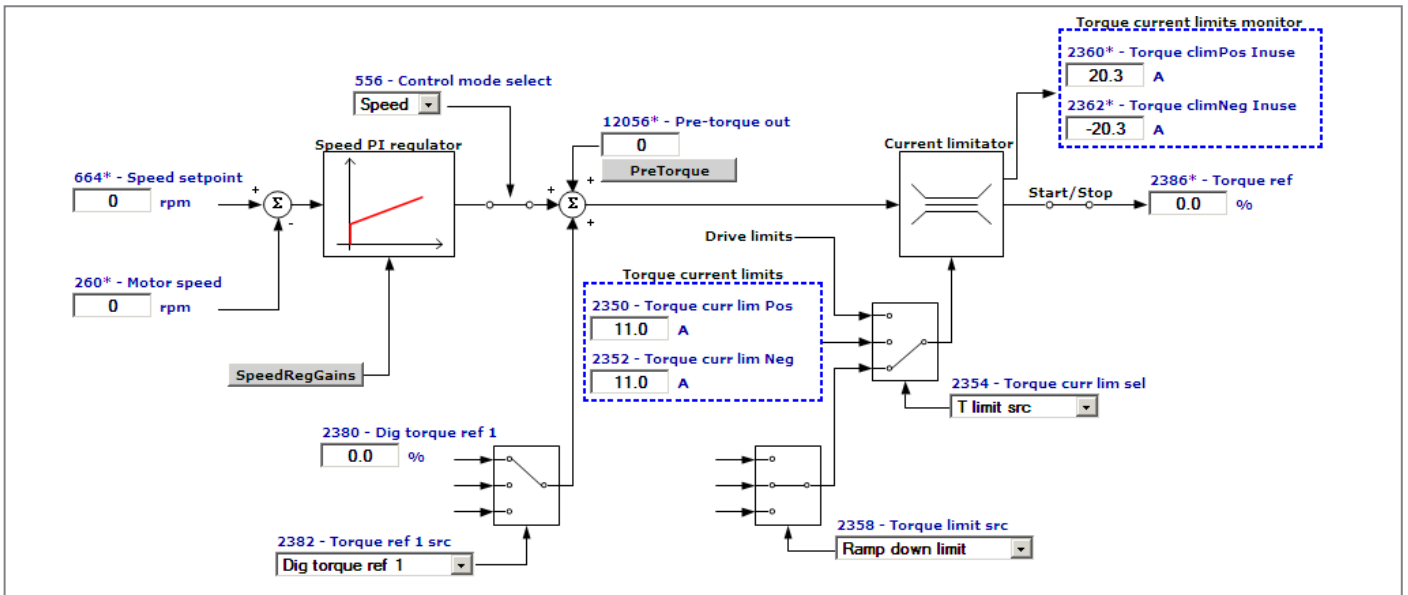

Gains adaptive (GainAdapt)

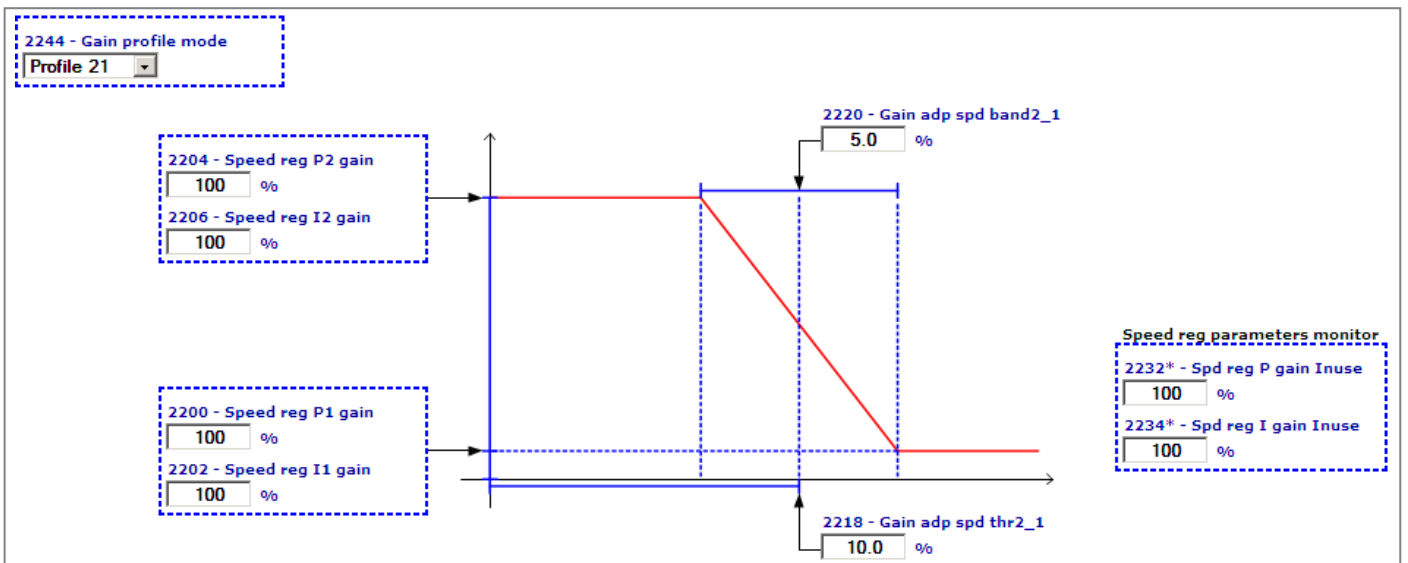
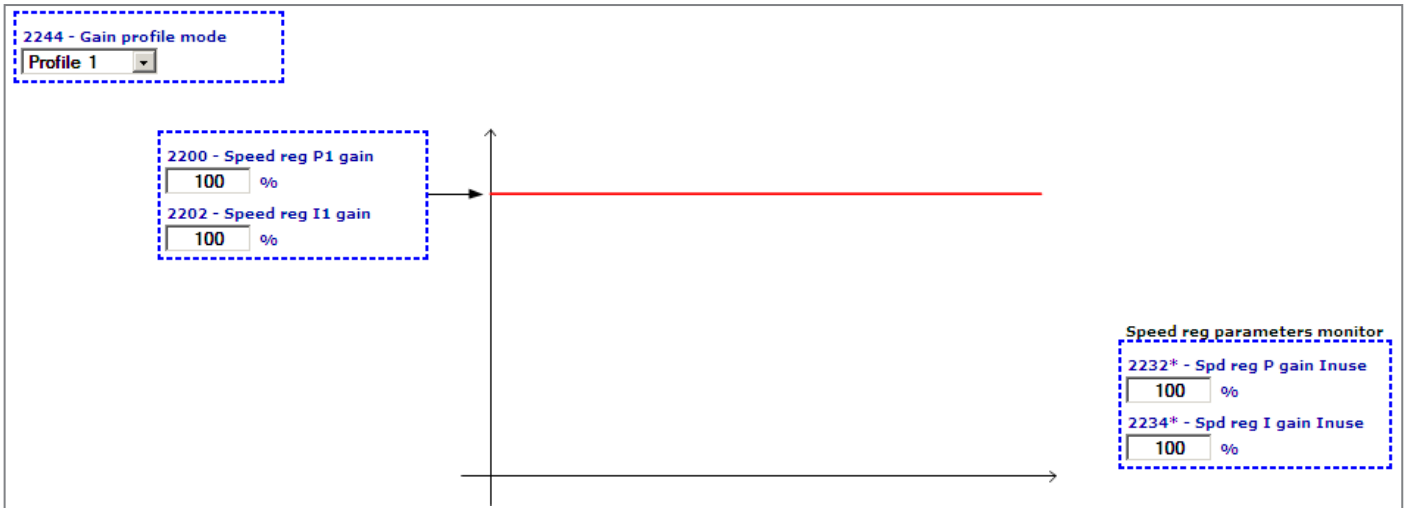

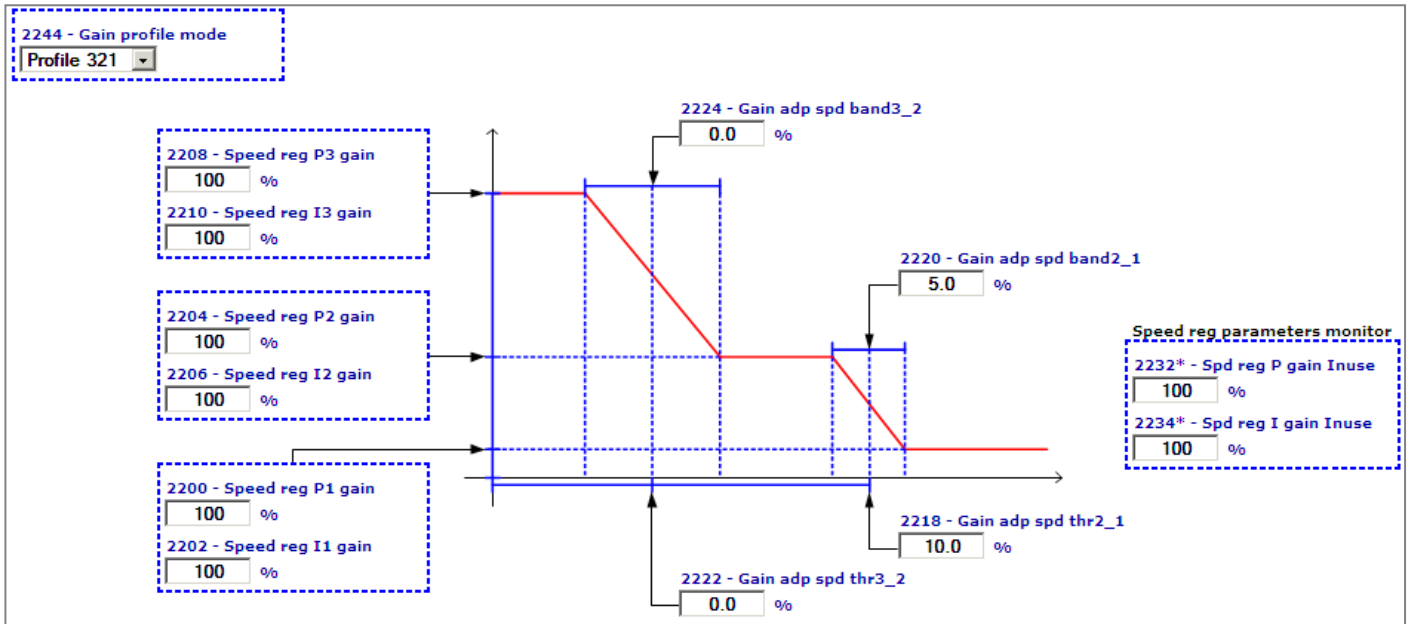
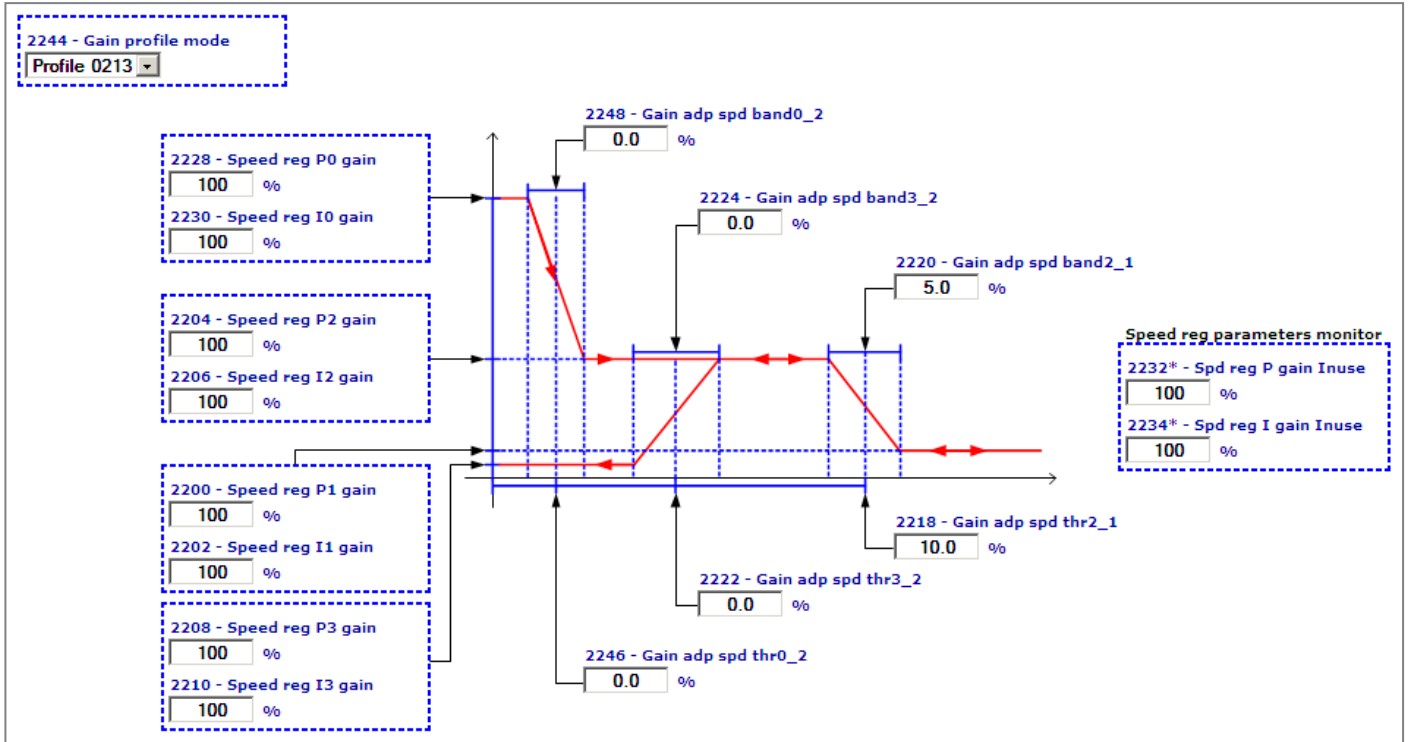

Appendix - 1.0 CANopen interface

CANopen is a communication profile for CanApplicationLayer-based industrial systems.

The reference document is the "CANopen application layer and communication profile" CiA 301 Version 4.2.0 21 February 2011 by CAN in Automation e. V.

The drive also implements part of the DS417 profile according to the specific CANopen Device Profile Drives and Motion Control V3.0.0 dated 14 December 2007.

The CAN protocol (ISO 11898) is CAN2.0A with an 11-bit identifier.

The integrated CANopen interface is developed as a "Minimum Field Device".

The data exchange is cyclic; the Master unit reads the Slave input data and writes the Slave output data.

Note!

CANopen is only present in ADL2.0-...-C models.

1.1 CANopen functions

This chapter describes the controlled functions of the CANopen communication profile.

Main features:

- 1) The "Mandatory Protocol boot-up" is managed.
- 2) The SYNC function is implemented.
- 3) The PDO asynchronous assignment is managed.
- 4) The Node Guarding and HeartBeat protocols are managed.
- 5) The emergency message is managed ("EMERGENCY").
- 6) The Dynamic ID distribution function (DBT slave) is not managed.
- 7) A "Generic Pre-Defined Master/Slave connection" is implemented to simplify the Master tasks during the initialization phase.
- 8) "Inhibit-Times" (in units of 100 uS) can be modified.
- 9) The high-resolution synchronization is not supported.
- 10) "TIME STAMP" is not managed.
- 11) On the access of the structured parameters, the OFFhex option subindex (access to the whole object) is not managed.
- 12) In order to obtain a higher efficiency level, only the "Expedited" data transfer (max. 4 Bytes) of the SDO services is managed.
- 13) The "communication profile area" parameters are not saved by a save command, which on the other hand works on the "manufacturer-specific" and "profile" areas.

1.1.1 Pre-defined Master/Slave Connection

The "Generic Pre-defined Master/Slave connection" allows a peer-to-peer communication between one Master and 127 Slaves; the Broadcast address is zero.

1.1.2 NMT Services (Network Management)

The NMT "mandatory" services are:

- Enter_Pre-Operational_State CS = 128 (80h)
- Reset_Node CS = 129 (81h)

Performs an adjustment software reset command.

- Reset_Communication CS = 130 (82h)

Also the following NMT services are managed:

- Start_Remote_Mode CS = 1
- Stop_Remote_Mode CS = 2

The COB-ID * of an initialization NMT service is always at 0; CS is the Command Specifier defining the NMT service.

1.1.3 Monitoring

The ADL300 drive supports the Node Guarding and HeartBeat mechanism. The Node Guarding configuration can be performed through the master via the standard Object Dictionary elements (1006h, 100Ch, 100Dh).

The Node Guarding threshold (maximum time between two NodeGuarding messages received from ADL) is calculated as: "Guard time" x "LifeTime Factor"

The HeartBeat is configured by means of the objects 1016h and 1017h. The threshold in this case is calculated as: "HeartBeat Time" x "LifeTime Factor".

Monitoring via NodeGuarding excludes monitoring via HeartBeat and vice versa: only one of the two systems can be active. The master must set the objects involved correctly.

The drive also checks the master's operation via the arrival of the Sync message (only if the "Communication Cycle period" is different from 0). The threshold (maximum time between two Sync messages received from ADL) is:

"Communication Cycle period" * "LifeTime Factor"

If one of the thresholds is exceeded, the drive changes the Operational status to Pre-Operational status, consequently generating the BusLoss alarm if it is also enabled.

Index	Name	Default value
1006h	Communication Cycle Period	64ms
100Ch	Guard Time	100ms
100D	Life time factor	3 (N.B.: this must always be different from 0)
1016h	Consumer heartbeat time	Nodeld = 0 , time = 0
1017h	Producer heartbeat time	0

The default settings shown therefore correspond to the use of the NodeGuarding protocol with a threshold of 100ms x 3 and a threshold control even on Sync at 64ms x 3. The HeartBeat is disabled.

1.1.4 Communication objects

This chapter describes the communication objects of the CANopen protocol; they are managed by the interface card.

The managed communication objects are:

- 1) 1 SDO reception Server.
- 2) 1 SDO transmission Server.
- 3) reception PDOs.
- 4) transmission PDOs.
- 5) 1 Emergency Object.
- 6) 1 Node Guarding - Life Guarding.
- 7) 1 SYNC object.

The following table lists the used communication objects with their priority level and the Message Identifier; the "Resulting COB-ID" is obtained by adding the Node-ID (card address) to the number.

OBJECT	PRIORITY	MESSAGE ID
1st SDO rx	6	1792 700h+Nodeld
1st SDO tx	6	1536 600h+Nodeld
1st PDO rx	2	1408 580h+Nodeld
1st PDO tx	2	512 200h+Nodeld
2nd PDO rx	2	384 180h+Nodeld
2nd PDO tx	2	768 300h+Nodeld
3st PDO rx	2	640 280h+Nodeld
3st PDO tx	2	512 400h+Nodeld
4th PDO rx	2	384 380h+Nodeld
4th PDO tx	2	768 500h+Nodeld
EMERGENCY	1	640 480h+Nodeld
NODE GUARDING & HB	not used	220 600h+Nodeld
SYNC	0	128 80h

Table 1.4.1: Communication Objects

The master NodeGuarding message is a remote type (remote RTR bit set in COB-ID). All other messages used by this implementation of the CANopen are not RTR.

1.1.5 Object Dictionary Elements

The Object Dictionary is accessible from a master CANopen and represents the set of objects used to configure, send and monitor size.

The following table shows the communication objects used and accessibility with master CANopen.

Index (hex)	Name
1000	Device Type
1001	Error Register
1002	Manufacturer status register

1005	COB-ID SYNC Message
1006	Communication cycle period
1008	Manufacturer Device Name
1010	Store parameter
1009	Manufacturer Hardware Version
100A	Manufacturer Software Version
100C	Guard Time
100D	Life Time Factor
1014	COB-ID Emergency
1016	HeartBeat time consumer
1017	HeartBeat time producer
1018	Identity object
1029	Error behavior object
1400	1st Receive PDO
1401	2nd Receive PDO
1402	3rd Receive PDO
1403	4th Receive PDO
1600	Receive PDO1 mapping parameter
1601	Receive PDO2 mapping parameter
1602	Receive PDO3 mapping parameter
1603	Receive PDO4 mapping parameter
1A00	Transmit PDO1 mapping parameter
1A01	Transmit PDO2 mapping parameter
1A02	Transmit PDO3 mapping parameter
1A03	Transmit PDO4 mapping parameter
1800	1st Transmit PDO
1801	2nd Transmit PDO
1802	3rd Transmit PDO
1803	4th Transmit PDO

Table 1.5.1: Objects used by the CANopen communication profile

The objects shown in bold in the table allow writing of the parameters assigned with the exchange of data in the PDO.

The allocation criterion is variable, and depends on the size (in bytes) of the parameter exchanged.

1.1.6 RX PDO Entries

The structure of the PDO Communication Parameter (index 1400h, 1401h) is:

- 1) Subindex 0 (Number of supported entries) = 2
- 2) The structure of Subindex 1 (COB-ID used by the PDO) is:
 - Bit 31 (valid/invalid PDO) can be set via SDO.
 - Bit 30 (RTR Remote Transmission Request) = 0 because this function is not supported.
 - Bit 29 = 0 because the 11-bit ID is used (CAN 2.0A).
 - Bits 11-28 are not used.
 - Bit 0-10 COB-ID (see table 1.4.1).
- 3) Cyclic-synchronous Subindex 2 (Transmission Type), or synchronous according to the master performed setting (1 if SYNC has been foreseen, 254...255 if asynchronous). If not stated, the synchronous mode is active.

1.1.7 TX PDO Entries

The structure of the PDO Communication Parameter (index 1800h, 1801h) is:

- 1) Subindex 0 (Number of supported entries) = 3
- 2) The structure of Subindex 1 (COB-ID used by the PDO) is:
 - Bit 31 (valid/invalid PDO) can be set via SDO.
 - Bit 30 (RTR Remote Transmission Request) = 0 because this function is not supported.
 - Bit 29 = 0 because the 11-bit ID is used (CAN 2.0A).
 - Bits 11-28 are not used.
 - Bit 0-10 COB-ID (see table 1.4.1).
- 3) Cyclic-synchronous Subindex 2 (Transmission Type), or synchronous according to the master performed setting (1 if SYNC has been foreseen, 254...255 if asynchronous). If not stated, the synchronous mode is active.
- 4) Inhibit time.

1.1.8 SDO Entries

Only the “Expedited” data transfer mode (max. 4 Bytes) is used.

- 1) Subindex 0 (Number of supported entries) = 3 because the device is a Server of the SDO service.
- 2) The structure of the Subindex 1 and 2 (COB-ID used by the SDO) is:
 - Bit 31 (valid/invalid SDO); it is equal to 1 because just the Default SDOs are used.
 - Bit 30 reserved = 0.
 - Bit 29 = 0 because the 11-bit ID is used (CAN 2.0A).
 - Bits 11-28 are not used.
 - Bit 0-10 COB-ID (see table 1.4.1).

The element “node ID of SDO’s client resp. server” is not supported because just the Default SDOs are used.

1.1.9 COB-ID SYNC Entries

The structure of the 32 bits contained in the COB-ID SYNC communication parameter is:

- Bit 31 = 1 because the CANopen interface card is a “consumer” of SYNC messages.
- Bit 30 = 0 because the interface card does not create SYNC messages.
- Bit 29 = 0 because the 11-bit ID is used (CAN 2.0A).
- Bits 11-28 are not used.
- Bit 0-10 COB-ID (see table 1.4.1).

1.1.10 COB-ID Emergency

The structure of the 32 bits contained in the COB-ID Emergency Message communication parameter is:

- Bit 31 = 0 because the CANopen interface card is not a “consumer” of Emergency messages.
- Bit 30 = 0 because the interface card creates Emergency messages.
- Bit 29 = 0 because the 11-bit ID is used (CAN 2.0A).
- Bits 11-28 are not used.
- Bit 0-10 COB-ID (see table 1.4.1).

1.2 CANopen management

The user interface of the CANopen protocol is performed via the drive parameters. The parameters are controlled via hierarchical menus. All the writing parameters referring to the field bus are active only after the drive reset. Here following is a list of drive parameters useful to control the CANopen protocol.

To enable CANopen, set parameter PAR 4000 **Fieldbus type** to CANopen or DS417.

The following parameters are available in the COMMUNICATION->FIELDBUS CONFIG menu:

PAR	Par Name	Type	Default value	Attr
4004	Fieldbus baudrate	Enum	None	Write
4006	Fieldbus address	2 byte unsigned	0	Write
4010	Fieldbus M->S enable	Enum	0n	Write
4012	Fieldbus alarm mode	2 byte unsigned	0	Write
4014	Fieldbus state	Enum	Stop	Read only

- Fieldbus baudrate = Sets the network baud rate. Values available for CANopen: 125k, 250k, 500k, 1M
- Fieldbus address = address of this slave node in the network, accepted values from 1 to 127
- Fieldbus M->S enable = if set to Off data in the RPDOs are not processed by the drive
- Fieldbus alarm mode = if set to 1 the drive generates Opt Bus Fault errors relating to the loss of communication (Bus Loss) even when the drive is not enabled.
- Fieldbus state = state of the communication for this node on the CANopen network: Stop, Pre-Operational, Operational.

1.3 Process Data Channel Control

This function allows to allocate the drive parameters or application variables to the Process Data Channel data.

As for the CANopen protocol, the PDC is performed via the PDO messages (Process data Object).

The CANopen protocol uses a number of words for the Process Data Channel (abbr. PDC Process Data Channel), which can always be set.

The fieldbus Process Data Channel configuration is the following:

Data 0 Data... Data n

The drive can both read and write the Process Data Channel data.

A datum can be made both of 2 and 4 bytes. The word "datum" refers to any quantity of bytes included between 0 and 16, if the byte total number required is not higher than 32.

Example:

It is possible to have:

- from 0 to 16 data with 2 bytes
- 1 datum with 4 bytes + from 0 to 14 data with 2 bytes
- 2 data with 4 bytes + from 0 to 12 data with 2 bytes
- ...
- 8 data with 4 bytes

The data exchanged via the PDC can be of two types:

- drive parameters
- variables of an MDPLc application. The use of the MDPLc variables is described in par. 1.3.1 and 1.3.2.

The master writes the data defined as PDC input and reads the data defined as PDC output.

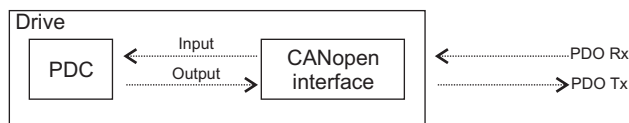

1.3.1 PDC Input Configuration (FB XXX MS Parameter)

Data exchanged in RPDOs are configured using the parameters in the COMMUNICATION->FIELDBUS M2S menu.

PAR 4030 **Fieldbus M->S2 ipa** = IPA of the parameter to be exchanged

Must contain a valid IPA corresponding to the parameter to be written or 0 if sys (PAR 4032...4172 **Fieldbus M->Sn sys**) is Fill or Mdplc; the parameter PAR 4020 **Fieldbus M->S1 ipa** must be assigned to the Lift Wdef Input, while the parameter PAR 4022 **Fieldbus M->S1 sys** must be set on Mdplc16

By selecting the corresponding enum PAR 4034 **Fieldbus M->S2 mon** for src type parameters (Source), the value of the parameter 4030 is automatically set at the IPA of the src.

For src type parameters with an FB type different from 0, the data arriving on the fieldbus is not written in the enum selection, but directly in the mon associated with the src.

If it contains a valid IPA and is forced to 0, the corresponding sys parameter takes on the Fill value (16 or 32 in relation to that shown before), ensuring that the structure of the exchanged data area is not modified.

PAR 4032 **Fieldbus M->S2 sys** = format of the data to be exchanged

This parameter is automatically changed to the recommended value when the corresponding PAR 4030...4170 **Fieldbus M->Sn ipa** is changed. The automatic value can be changed by the user, however, the permitted values depend on the parameter.

Data mapping in PDOs is performed on the basis of the data format set in Fieldbus M->Sn sys according to the following rules:

- PDOs are filled starting from RPDO1
- When the PDO contains 4 words it is full and the next RPDO is filled with a maximum of 4 PDOs
- 32-bit data (long or float) cannot be split among PDOs, they must be placed inside the PDO (an alarm is generated)
- PDOs containing fewer than 4 words can be created, using **Fieldbus M->Sn dest**= None but assigned (**Fieldbus M->Sn sys** other than Not Assigned, Fill16 or Fill32) after an assigned datum.
(N.B.: if assigned as Fill16 or Fill32, the datum is included in the PDO anyway)
- At the first **Fieldbus M->Sn sys** = Not Assigned parameter the PDOs are complete. The size of the last PDO thus depends on the data that have been assigned.

- **Example : RPDO1 di 2 word and RPDO2 di 2 word:**

Fieldbus M->S1 dest = Ramp ref 1 src

Fieldbus M->S1 sys = EU

Fieldbus M->S2 dest = Word decomp src

Fieldbus M->S2 sys = Count 16

Fieldbus M->S3 dest = None

Fieldbus M->S3 sys = Count 32

Fieldbus M->S4 dest = Compare 1 src

Fieldbus M->S4 sys = Count32

Fieldbus M->S5 sys = Not Assigned

1.3.2 PDC Output Configuration (FB XXX SM Parameter)

Data exchanged in RPDOs are configured using the parameters in the COMMUNICATION->FIELDBUS S2M menu (refer to the drive manual).

Data mapping in PDOs is performed on the basis of the data format set in **Fieldbus M->Sn sys** according to the following rules:

- PDOs are filled starting from TPDO1
- When the PDO contains 4 words it is full and the next TPDO is filled with a maximum of 4 PDOs.
- 32-bit data (long or float) cannot be split among PDOs, they must be placed inside the PDO (an alarm is generated).
- PDOs with fewer than 4 words can be created, using **Fieldbus S->Mn src**= None Used but assigned (**Fieldbus M->Sn sys** other than Not Assigned, Fill16 or Fill32) after an assigned datum.
- At the first **Fieldbus S->Mn sys** = Not Assigned parameter the PDOs are complete. The size of the last PDO thus depends on the data that have been assigned.

1.3.3 Use of the PDC in MDPLC Applications

It is possible to configure both the PDC input and output data in order to allow the data direct access via the MDPLC application code.

For read data simply set **Fieldbus M->Sn sys** to MDPLC16 or MDPLC32, leaving **Fieldbus M->Sn dest** = None.

The MDPLC application can now read the incoming datum directly from the **Fieldbus M->Sn mon** parameter.

Write data are configured by setting **Fieldbus S->Mn src** = Dig Fieldbus S->Mn.

Fieldbus S->Mn sys is automatically set to MDPLC. The application writes the datum in the **Dig Fieldbus S->Mn** parameter to send it to the bus.

1.4 SDO management

The SDO service is always available.

The drive parameters can be accessed via the "MSPA" Manufacturer Specific Profile Area (2000hex< index <5FFFhex).

The index to be shown in the SDO command to access a drive parameter is obtained via the following rules:

SDO index = PAR + 2000h

SDO subindex = 1

The Data field must contain the value of the drive parameter.

Example:

Writing the value 1m/s in the PAR 11020 **Multi speed 0** (2B0C hex).

The following information is required:

- 1) The SDO index resulting from the formula is
 $2000\text{hex} + 258\text{hex} = 2258\text{h}$
- 2) The value to be written is 1, corresponding to 1 hex.
- 3) Parameter writing code = 22h
- 4) Parameter reading code = 40h
- 5) Sub-index = 01h

The ipaCan parameter and relative value is written by first inserting the lower part of the address in hexadecimal and then the higher part (Value to be written LL-LH-HL-HH).

Example of value 1 writing:

MessageID	Writing Code	Lower part IpaCan	Higher part IpaCan	Subindex	Value of parameter LL	Value of parameter LH	Value of parameter HL	Value of parameter HH
601h	22h	0Ch	43h	01h	01h	00h	00h	00h
	Byte 0	Byte 1	Byte 2	Byte 3	Byte 4	Byte 5	Byte 6	Byte 7

In the event of success the following message is received:

MessageID	Writing Code	Lower part IpaCan	Higher part IpaCan	Subindex	Value of parameter LL	Value of parameter LH	Value of parameter HL	Value of parameter HH
601h	60h	0Ch	43h	01h	01h	00h	00h	00h
	Byte 0	Byte 1	Byte 2	Byte 3	Byte 4	Byte 5	Byte 6	Byte 7

Example of reading: with value 1

MessageID	Writing Code	Lower part IpaCan	Higher part IpaCan	Subindex	Not significant	Not significant	Not significant	Not significant
601h	40h	0Ch	43h	01h	00h	00h	00h	00h
	Byte 0	Byte 1	Byte 2	Byte 3	Byte 4	Byte 5	Byte 6	Byte 7

In the event of success the following message is received:

MessageID	Reading code	Lower part IpaCan	Higher part IpaCan	Subindex	Value of data			
601h	43h	0Ch	43h	01h	01h	00h	00h	00h
	Byte 0	Byte 1	Byte 2	Byte 3	Byte 4	Byte 5	Byte 6	Byte 7

Index		Subindex				
0Ch	4Bh	01h	01h	00h	00h	00h
Drive parameter index		Subindex	Drive parameter value to be assigned to SDO			

In case an error occurs during the parameter reading or setting, the CANopen interface sends an Abort domain transfer message; the value of Application-error-codes has the following meanings:

Error class	Error code	Additional code (hex)	Meaning
6	0	0	Parameter doesn't exist
8	0	22	Access failed because of present device state
6	1	2	Read/Write only error
8	0	0	Generic error
6	9	32	Minimum value
6	9	31	Maximum value
5	4	0	SDO time_out
5	4	1	Invalid command
3	9	30	Invalid value

1.5 Alarms

Fieldbus alarms

The bus failure is signaled via the “Opt Bus Fault” alarm. As for CANopen, the possible failure causes are:

- “Bus-off” condition of the CAN line;
- the drive has not been enabled in the “Operational” mode;
- the “Life Guarding” threshold has been overcome.

This alarm becomes active only when the drive is enabled.

If ON, the PAR 4014 **Fieldbus alarm mode** parameter enables the generation of the “Field bus failure” alarm also when the drive is disabled.

Codice	Cfg	Description	Actions
0		Bus Loss	Check line for noise, terminations , problems with cabling
FF01	*	Fieldbus type does not match expansion card	Please contact Technical Assistance.
FF02	*	Wrong baudrate selected	Check “Fieldbus baudrate” is one of 125k, 250k, 500k, 1M
FF03	*	Invalid address for node	Check “Fieldbus address”
FF04	*	Error initializing CAN interface	Internal error, contact manufacturer
FF14..FF23	*	Wrong object selected for mapping in channel M2S n	Check “Fieldbus M-> Sn Dest
FF24..FF33	*	More than 1 Src pointing to M2S Channel n	Check for multiple destinations on “Fieldbus M-> Sn Dest”
FF34..FF43	*	M2S Channel n , data size is wrong (16 bits on 32 bits or 32 bits on 16 bits parameter)	Check “Fieldbus M-> Sn sys”
FF44..FF53	*	Invalid parameter in channel S2M n	Check “Fieldbus S-> Mn src”
FF54..FF63	*	S2M Channel n , data size is wrong (16 bits on 32 bits or 32 bits on 16 bits parameter)	Check “Fieldbus S-> Mn sys”
FF64..FF73	*	Wrong object selected for mapping in channel S2M n	Check “Fieldbus S-> Mn src”
FF74..FF83	*	M2S Channel n : too many words in PDC	“Fieldbus M-Sn dest” & “Fieldbus M-> Sn sys” address more than 16 words in PDC
FF84..FF93	*	S2M Channel n : too many words in PDC	“Fieldbus S-> Mn src” & “Fieldbus S-> Mn sys” address more than 16 words in PDC
FFB4..FFC3	*	Internal database error on channel n	Internal error, contact manufacturer
8110		CAN msg overflow	Too many packets for selected baudrate
8130		LifeGuard/HeartBeat error	Software timeout from master
FFC5		Wrong NMT message length	Check NMT packets
FFC6		Invalid NMT command	Check NMT packets
FFC7		CAN bus off	Check line state for problems

Drive alarm handling

Drive alarms are managed by means of an Emergency message containing the error code relating to the alarm that is generated, according to the table below:

Selection	Code
No alarm	0x0000
Overvoltage	0x3210
Undervoltage	0x3220
Ground fault	0x2110
Overcurrent	0x2310
Desaturation	0x2130
MultiUndervolt	0xFF06
MultiOvercurr	0xFF07
TechnMultiDesat	0xFF08
Heatsink OT	0x4210
HeatsinkS OTUT	0x4310
Intakeair OT	0x4130
Motor OT	0xFF0C
Drive overload	0x8311
Motor overload	0x7121
Bres overload	0x7112
Phaseloss	0xFF10
Opt Bus fault	0xFF11
Opt 1 IO fault	0xFF12
Opt Enc fault	0x3130
External fault	0x9000
Speed fbk loss	0x7310
Overspeed	0x8400

Selection	Code
Plc1 fault	23
Plc2 fault	24
Plc3 fault	25
Plc4 fault	26
Plc5 fault	27
Plc6 fault	28
Plc7 fault	29
Plc8 fault	30
Emg stop alarm	31
Watchdog	32
Trap error	33
System error	34
User error	35
Power down	36
Speed ref loss	37
Not Used1	38
Opt 2 IO fault	39
Not Used2	40
Not Used3	41
Not Used4	42
Not Used5	43
Not Used6	44
Param error	45

1.6 Configuration example

This chapter provides an example of how to configure the parameters of ADL300 drives so that they can be read and written by a CANopen master via the processing channels (PDO). See the chapter 1.4 for the configuration channels (SDO).

The paragraph 1.6.1 provides the information required on a CANopen master controlling a machine. The paragraph 1.6.2 contains basic information for programming the ADL300 drive starting from the factory settings.

In this example, drive programming is performed using the GF-Express configurator. All operations can, of course, be performed via keypad.

1.6.1 CANopen Master

This section contains an example of data exchange seen from the master side. This is the data normally contained in the machine specifications in the case of applications controlled by a CANopen master.

1.6.1.1 Description of Master -> Slave PDO Communication

There are two parameters to be written via the processing channels. The first is a control word, in which the single bits contain certain commands (e.g. enable, start, etc.). The second processing channel contains the ramp reference 1 (RampRef1) in rpm.

CANopen PDO: Master -> Drive (max 16 word)

Position	Description	Format	Unit of Measure
Word1 M -> S	Control word	16 bit Word	...
Word2 M -> S	MultiSpeed 7	Float	Rpm
Word3 M -> S			
...			
...			
Word16 M > S			

CONTROL WORD, Example:

Bit	Description	Remarks
0	EnableCmd	Enable command from CANopen master
1	StartFwdCmd	Start forward command
2	StartRevCmd	Start reverse command
3	Emergency mode	Emergency operation command
4	MltSpd S0	Multi speed 0 sel
5	MltSpd S1	Multi speed 1 sel
6	MltSpd S2	Multi speed 2 sel
7	Free	
8	Free	
9	Free	
10	Free	
11	Free	
12	Free	
13	Free	
14	Free	
15	Free	

1.6.1.2 Description of PDO Slave -> Master Communication

The can master reads three parameters from the drive: the first two contain, respectively the two status words (Lift Status Word1 and Lift Status Word2) whose individual bits contain information of the drive's status (e.g. LiftEnable.). Only Lift Status Word1 is used by this application, Lift Status Word 2 can be omitted. The third parameter is the current speed in rpm.

CANopen PDO Slave > Master (max 16 Word)

Position	Description	Format	Unit of Measure
Word1 S -> M	Status Word	16 bit Word	BitWide
Word2 S -> M	Actual Speed	Int 16 bit	rpm
Word3 S -> M			
...			
...			
Word16 S -> M			

Lift control outputs can usually be connected to the PAD parameters according to the table below:

Bit	Description	Remarks
0	LiftEnable	Lift enable command.
1	RunCont	Run command contactor
2	UpCont	Up command contactor
3	DownCont	Down command contactor
4	BrakeCont	Brake command contactor
5	LiftDcBrake	DC brake function command (firmware)
6	Brake2	Brake control signal (See sequences)
7	DoorOpen	Open door command
8	LiftStart	Lift start command
9	----	
10	Lift status word	Contains copy of the StatusWord (selectable via SelLiftStatWord)
11	----	
12	----	
13	----	
14	InputVariable	Connected to the input selector
15	LiftWdecln	Connected to the LifWDecomp selector
16		

LiftStatusWord (connected to Pad11)

Bit	Description	Remarks
0	LiftEnable	Lift enable command.
1	RunCont	Run command contactor
2	UpCont	Up command contactor
3	DownCont	Down command contactor
4	BrakeCont	Brake command contactor
5	LiftDcBrake	DC brake function command (firmware)
6	Brake2	Brake control signal (See sequences)
7	DoorOpen	Open door command
8	Drive Ok	
9	SpeedIsZero	
10	SpeedReflsZero	
11		
12		
13		
14		
15	(EPC Enable)	

Outputs available directly on the drive:

- Drive OK
- SpeedIsZero

1.6.2 ADL300 Configuration

The example given in this section is based on the assumption that the parameters of the ADL300 drive are the factory settings (**Default parameter** command). Use of the keypad is recommended for performing commissioning in the first phase (see the ADL300 "Quick start guide"). Then the motor should be moved using the digital input commands.

Similarly, a system start-up wizard must be available on the GF_Express configurator .

The programming sequence is as follows:

- **Fieldbus configuration**
- **Fieldbus M2S configuration**
- **LIFT\LIFT IN/OUT configuration**
- **Fieldbus S2M configuration**

1.6.2.1 FIELDBUS CONFIG

This example shows the parameter settings to be performed with 500Kbaud CANopen and address 1.

- Menü 20.2- COMMUNICATION\FIELDBUS CONFIG.
- Example of configuration with **500Kbaud CANopen address 1**:

In the example, it is assumed that the drive is node 1 and the CANopen communication takes place with a baud rate of 500k. Make sure that all fieldbus settings and configurations are only effective after the drive's next reset.

Program the fieldbus menu parameters as shown in the following figure:

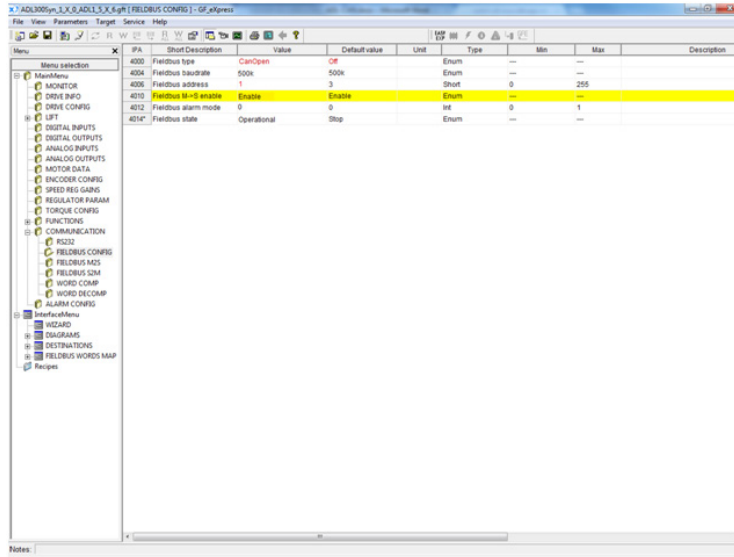

The status is pre-operational and the CAN led on the local Keypad is flashing.

Under these conditions, the process communication channels are not active.

At the end from the drive's programming (see below) and communication can be activated by the master through the NMT "start node" command.

Upon receipt of this command, the FieldBus parameter goes into the Operational condition and the CAN led on the keypad goes from flashing to fixed. Only at this point are the process channels active.

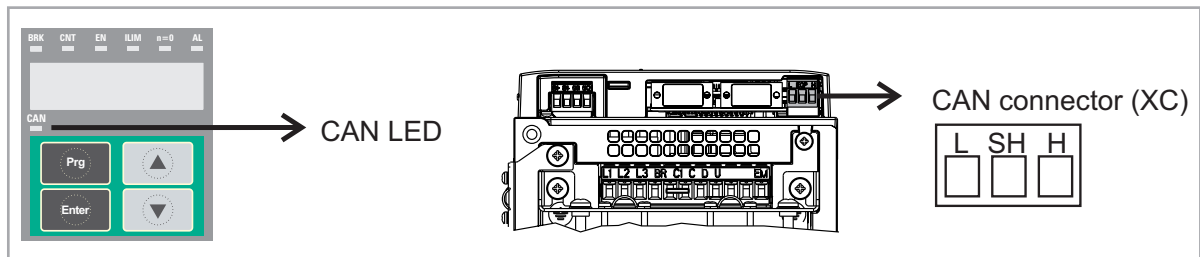

Terminal	Name	Function	Cable cross-section
L	CAN_L	CAN_L bus line (low dominant)	0.2 ... 2.5 mm ² AWG 26 ... 12
SH	CAN_SHLD	CAN shielding	
H	CAN_H	CAN_H bus line (high dominant)	

LEDs	Meaning
CAN (green)	
Off	Stop
Flashing	Pre-operational
On	Operational

1.6.2.2 Fieldbus M2S configuration

As regards communication through process channels (PDC), in the configuration in this example, the first channel is reserved for writing lift commands (writing of the control word).

Control word configuration is achieved by using an internal Lift Decomp parameter. The following figure shows the programming of this control word on the first word M → S. On the second word M → S, the **Multi-speed 7 [11034]** parameter is programmed:

“Expert” mode:

The screenshot shows the ADL300 software interface with the 'FIELDBUS M2S' configuration window open. The table below represents the data visible in the main window.

Menu	IPA	Short Description	Value	Default value	Unit	Type	Min	Max	Description
Menu selection	4020	Fieldbus M->S1 ipa	0	0		UnsignedShort	0	20000	
MainMenu	4022	Fieldbus M->S1 sys	Mdpic 16	Not assigned		Enum	---	---	
MONITOR	4024*	Fieldbus M->S1 mon	0	---		Int	---	---	
DRIVE INFO	4026	Fieldbus M->S1 dv	1	1		Float	1	1000	
DRIVE CONFIG	4030	Fieldbus M->S2 ipa	11034	0		UnsignedShort	0	20000	
LIFT	4032	Fieldbus M->S2 sys	Par 32	Not assigned		Enum	---	---	
DIGITAL INPUTS	4034*	Fieldbus M->S2 mon	0	---		Int	---	---	
DIGITAL OUTPUTS	4036	Fieldbus M->S2 dv	1	1		Float	1	1000	
ANALOG INPUTS	4040	Fieldbus M->S3 ipa	0	0		UnsignedShort	0	20000	
ANALOG OUTPUTS	4042	Fieldbus M->S3 sys	Not assigned	Not assigned		Enum	---	---	
MOTOR DATA	4044*	Fieldbus M->S3 mon	0	---		Int	---	---	
ENCODER CONFIG	4046	Fieldbus M->S3 dv	1	1		Float	1	1000	
SPEED REG GAINS	4050	Fieldbus M->S4 ipa	0	0		UnsignedShort	0	20000	
REGULATOR PARAM	4052	Fieldbus M->S4 sys	Not assigned	Not assigned		Enum	---	---	
TORQUE CONFIG	4054*	Fieldbus M->S4 mon	0	---		Int	---	---	
FUNCTIONS	4056	Fieldbus M->S4 dv	1	1		Float	1	1000	
COMMUNICATION	4060	Fieldbus M->S5 ipa	0	0		UnsignedShort	0	20000	
RS232	4062	Fieldbus M->S5 sys	Not assigned	Not assigned		Enum	---	---	
FIELDBUS CONFIG	4064*	Fieldbus M->S5 mon	0	---		Int	---	---	
FIELDBUS M2S	4066	Fieldbus M->S5 dv	1	1		Float	1	1000	
FIELDBUS S2M	4070	Fieldbus M->S6 ipa	1	0		UnsignedShort	0	20000	
WORD COMP	4072	Fieldbus M->S6 sys	Not assigned	Not assigned		Enum	---	---	
ALARM CONFIG	4074*	Fieldbus M->S6 mon	0	---		Int	---	---	
InterfaceMenu	4076	Fieldbus M->S6 dv	1	1		Float	1	1000	
WIZARD	4080	Fieldbus M->S7 ipa	0	0		UnsignedShort	0	20000	
DIAGRAMS	4082	Fieldbus M->S7 sys	Not assigned	Not assigned		Enum	---	---	
DESTINATIONS	4084*	Fieldbus M->S7 mon	0	---		Int	---	---	
FIELDBUS WORDS MAP	4086	Fieldbus M->S7 dv	1	1		Float	1	1000	
Recipes	4090	Fieldbus M->S8 ipa	0	0		UnsignedShort	0	20000	
	4092	Fieldbus M->S8 sys	Not assigned	Not assigned		Enum	---	---	
	4094*	Fieldbus M->S8 mon	0	---		Int	---	---	

1.6.2.3 LIFT IN/OUT configuration

At this point, simply connect the individual Lift Decomp bits. Programming from the digital input to LIFT DECOMP LIFT/ INPUTS/OUTPUTS bit as shown in the figure below:

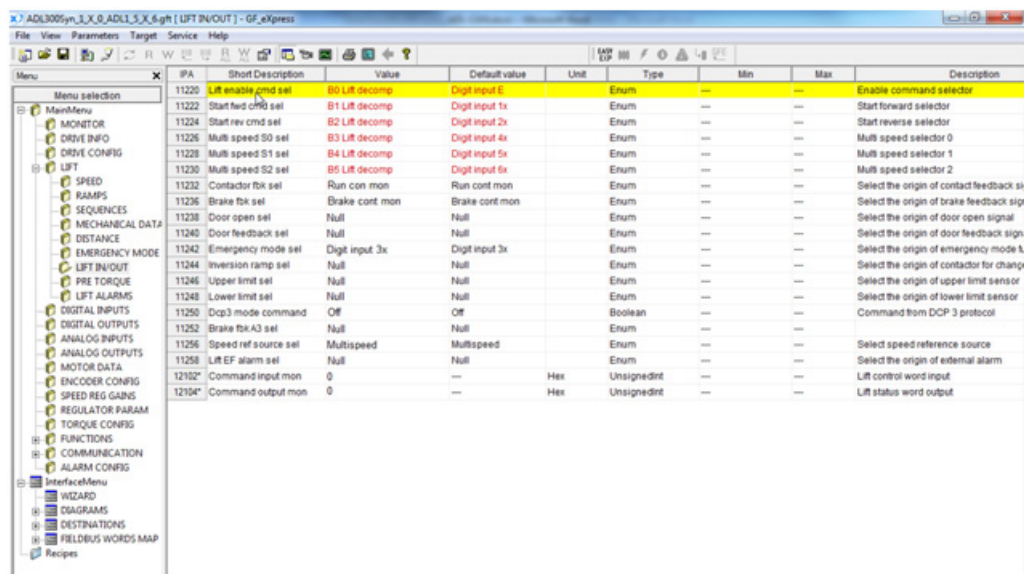

The screenshot shows a software window titled "ADL300Syn_2_X_0_ADL3_X_6_gh | LIFT IN/OUT | - GF_xpress". The main area displays a table with columns: IPA, Short Description, Value, Default value, Unit, Type, Min, Max, and Description. The table lists various parameters related to lift control, including LIFT enable, start forward/reverse selectors, multi-speed selectors, contactor feedback signals, brake feedback, door open signals, emergency mode, inversion ramp, upper/lower limit sensors, DCP3 mode command, brake feedback, speed reference source, LIFT alarm, command input/output monitoring, and torque command.

IPA	Short Description	Value	Default value	Unit	Type	Min	Max	Description
11220	Lift enable cmd sel	B0 Lift decomp	Digit input E		Enum	---	---	Enable command selector
11222	Start fwd cmd sel	B1 Lift decomp	Digit input 1x		Enum	---	---	Start forward selector
11224	Start rev cmd sel	B2 Lift decomp	Digit input 2x		Enum	---	---	Start reverse selector
11226	Multi speed S0 sel	B3 Lift decomp	Digit input 4x		Enum	---	---	Multi speed selector 0
11228	Multi speed S1 sel	B4 Lift decomp	Digit input 5x		Enum	---	---	Multi speed selector 1
11230	Multi speed S2 sel	B5 Lift decomp	Digit input 6x		Enum	---	---	Multi speed selector 2
11232	Contactr fbk sel	Run con mon	Run cont mon		Enum	---	---	Select the origin of contact feedback signal
11236	Brake fbk sel	Brake cont mon	Brake cont mon		Enum	---	---	Select the origin of brake feedback signal
11238	Door open sel	Null	Null		Enum	---	---	Select the origin of door open signal
11240	Door feedback sel	Null	Null		Enum	---	---	Select the origin of door feedback signal
11242	Emergency mode sel	Digit input 3x	Digit input 3x		Enum	---	---	Select the origin of emergency mode signal
11244	Inversion ramp sel	Null	Null		Enum	---	---	Select the origin of contactor for change
11246	Upper limit sel	Null	Null		Enum	---	---	Select the origin of upper limit sensor
11248	Lower limit sel	Null	Null		Enum	---	---	Select the origin of lower limit sensor
11250	Dcp3 mode command	Off	Off		Boolean	---	---	Command from DCP 3 protocol
11252	Brake fbk A3 sel	Null	Null		Enum	---	---	
11256	Speed ref source sel	Multispeed	Multispeed		Enum	---	---	Select speed reference source
11258	LIFT EF alarm sel	Null	Null		Enum	---	---	Select the origin of external alarm
12102	Command input mon	0	---	Hex	Unsignedint	---	---	Lift control word input
12104	Command output mon	0	---	Hex	Unsignedint	---	---	Lift status word output

Now all lift sequences are controlled via the LiftWdecomp bits in the same way as described in the manual using digital inputs.

Parameter 12102 **Command input mon**, displays state of word in Hex.

After running a save command and switching the drive on again, you can check the correct configuration of channels M → S as shown in the figure:

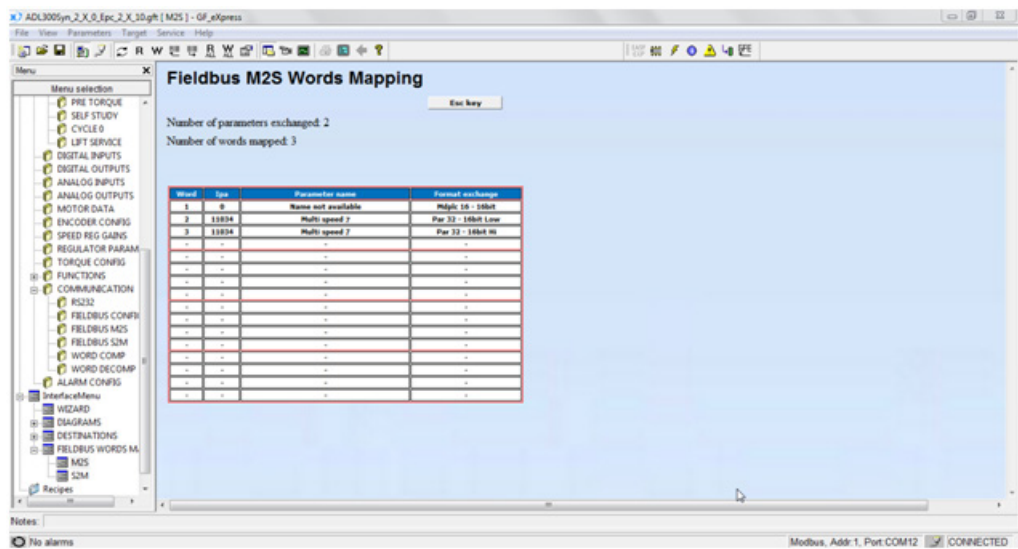

The screenshot shows a software window titled "ADL300Syn_2_X_0_Epc_2_X_10_gh | M2S | - GF_xpress". The main area is titled "Fieldbus M2S Words Mapping" and shows a table with columns: Word, Type, Parameter name, and Format exchange. The table lists three parameters: Word 1 (Type 0, Name not available, Format: 16 - 16bit), Word 2 (Type 13924, Name: Multi speed 7, Format: Par 32 - 16bit Low), and Word 3 (Type 13924, Name: Multi speed 7, Format: Par 32 - 16bit Hi). Below the table, there are several rows of empty cells with dashes. At the bottom, it says "Notes: No alarms" and "Modbus, Addr: 1, Port: COM12 CONNECTED".

Word	Type	Parameter name	Format exchange
1	0	Name not available	16bit - 16bit
2	13924	Multi speed 7	Par 32 - 16bit Low
3	13924	Multi speed 7	Par 32 - 16bit Hi

1.6.2.4 Fieldbus S2M configuration

The configuration of these channels takes place in the Fieldbus S2M menu. Lift Status Word 1 and 2 are used to program the first and second process channels. Word 2 status can be omitted.

The third channel is programmed on the 260 parameter (**Motor Speed**).

The following figure shows the S→M programming of the example:

Menu	IP Address	Short Description	Value	Default value	Unit	Type	Min	Max	Description
Menu selection	4180	Fieldbus S→M1 ipa	4184	0		UnsignedShort	0	20000	
MainMenu	4182	Fieldbus S→M1 sys	Mdplc 16	Not assigned		Enum	---	---	
MONITOR	4184	Dig Fieldbus S→M1	343	0		Int	---	---	
DRIVE INFO	4186	Fieldbus S→M1 mul	1	1		Float	1	1000	
DRIVE CONFIG	4190	Fieldbus S→M2 ipa	4194	0		UnsignedShort	0	20000	
LIFT	4192	Fieldbus S→M2 sys	Mdplc 16	Not assigned		Enum	---	---	
DIGITAL INPUTS	4194	Dig Fieldbus S→M2	0	0		Int	---	---	
DIGITAL OUTPUTS	4196	Fieldbus S→M2 mul	1	1		Float	1	1000	
ANALOG INPUTS	4200	Fieldbus S→M3 ipa	260	0		UnsignedShort	0	20000	
ANALOG OUTPUTS	4202	Fieldbus S→M3 sys	Eu	Not assigned		Enum	---	---	
MOTOR DATA	4204	Dig Fieldbus S→M3	0	0		Int	---	---	
ENCODER CONFIG	4206	Fieldbus S→M3 mul	1	1		Float	1	1000	
SPEED REG GAINS	4210	Fieldbus S→M4 ipa	0	0		UnsignedShort	0	20000	
REGULATOR PARAM	4212	Fieldbus S→M4 sys	Not assigned	Not assigned		Enum	---	---	
TORQUE CONFIG	4214	Dig Fieldbus S→M4	0	0		Int	---	---	
FUNCTIONS	4216	Fieldbus S→M4 mul	1	1		Float	1	1000	
COMMUNICATION	4220	Fieldbus S→M5 ipa	0	0		UnsignedShort	0	20000	
RS232	4222	Fieldbus S→M5 sys	Not assigned	Not assigned		Enum	---	---	
FIELDBUS CONFIG	4224	Dig Fieldbus S→M5	0	0		Int	---	---	
FIELDBUS M2S	4226	Fieldbus S→M5 mul	1	1		Float	1	1000	
FIELDBUS S2M	4230	Fieldbus S→M6 ipa	0	0		UnsignedShort	0	20000	
WORD COMP	4232	Fieldbus S→M6 sys	Not assigned	Not assigned		Enum	---	---	
WORD DECOMP	4234	Dig Fieldbus S→M6	0	0		Int	---	---	
ALARM CONFIG	4236	Fieldbus S→M6 mul	1	1		Float	1	1000	
InterfaceMenu	4240	Fieldbus S→M7 ipa	0	0		UnsignedShort	0	20000	
Recipes	4242	Fieldbus S→M7 sys	Not assigned	Not assigned		Enum	---	---	
	4244	Dig Fieldbus S→M7	0	0		Int	---	---	
	4246	Fieldbus S→M7 mul	1	1		Float	1	1000	
	4250	Fieldbus S→M8 ipa	0	0		UnsignedShort	0	20000	
	4252	Fieldbus S→M8 sys	Not assigned	Not assigned		Enum	---	---	
	4254	Dig Fieldbus S→M8	0	0		Int	---	---	
	4256	Fieldbus S→M8 mul	1	1		Float	1	1000	
	4260	Fieldbus S→M9 ipa	0	0		UnsignedShort	0	20000	
	4262	Fieldbus S→M9 sys	Not assigned	Not assigned		Enum	---	---	
	4264	Dig Fieldbus S→M9	0	0		Int	---	---	
	4266	Fieldbus S→M9 mul	1	1		Float	1	1000	
	4270	Fieldbus S→M10 ipa	0	0		UnsignedShort	0	20000	
	4272	Fieldbus S→M10 sys	Not assigned	Not assigned		Enum	---	---	
	4274	Dig Fieldbus S→M10	0	0		Int	---	---	
	4276	Fieldbus S→M10 mul	1	1		Float	1	1000	
	4280	Fieldbus S→M11 ipa	0	0		UnsignedShort	0	20000	

In a similar manner, after a drive save and restart, the correct Slave → Master channel programming can be checked:

Fieldbus S2M Words Mapping

Number of parameters exchanged: 3
Number of words mapped: 3

Word	ip	Parameter name	Format exchange
1	4184	Dig Fieldbus S→M1	Mdplc 16 - 16bit
2	4194	Dig Fieldbus S→M2	Mdplc 16 - 16bit
3	260	Motor speed	Eu - 16bit
-	-	-	-
-	-	-	-
-	-	-	-
-	-	-	-
-	-	-	-
-	-	-	-
-	-	-	-
-	-	-	-

1.6.2.5 Configuration check

A selection of communication checking notes/tips.

- PDO communication is only active in “On line Mode”. Check the status via GF-eXpress or a led on a local keypad.
- For Master -> Slave communication in FIELDBUS M2S menu, the value received from the communication channel can be checked (e.g. the parameter **Fieldbus M->S1 mon** [4024] is for the first channel).
- If communication is in EU (engineering units), remember that the value read on FIELDBUS M2S is in internal units.

1.6.2.6 Configuration errors

If a mistake has been made in configuring a channel, the “Option bus fault” drive alarm is activated upon starting up and provides an error code indicating the channel which has generated the alarm. The list of error codes is available in chapter 1.5 of this appendix.

With GF-eXpress simply connect to the relevant HTML page as shown in the following figure:

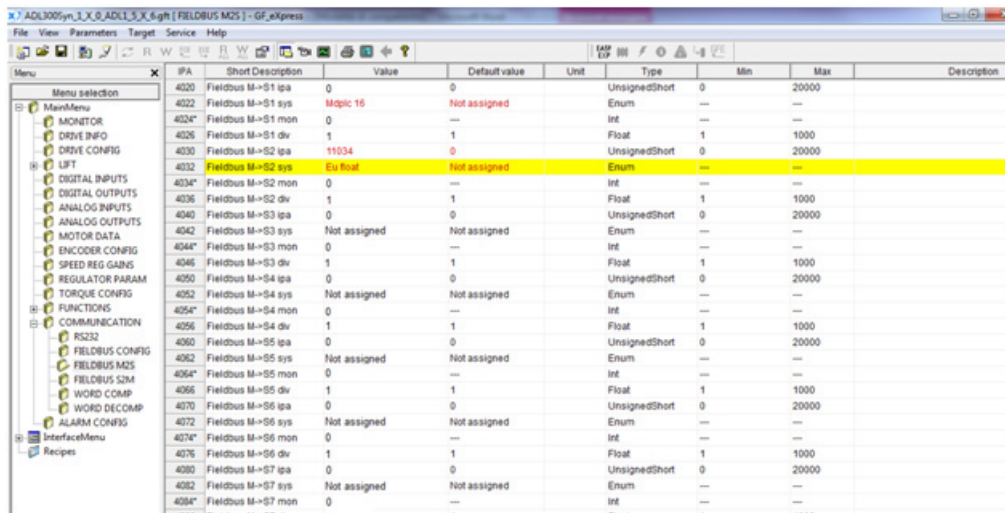
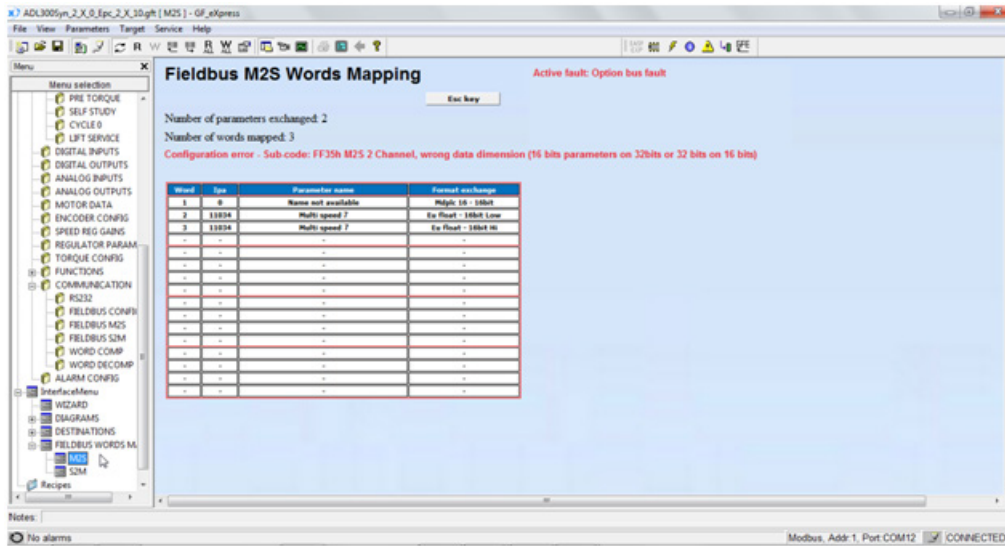

Appendix - 2.0 Configuring the Drive to manage Peripheral Encoders

This appendix contains guidelines for configuring drive parameters in installations with a peripheral encoder, i.e., with the encoder positioned on the tangent of the motor rotor.

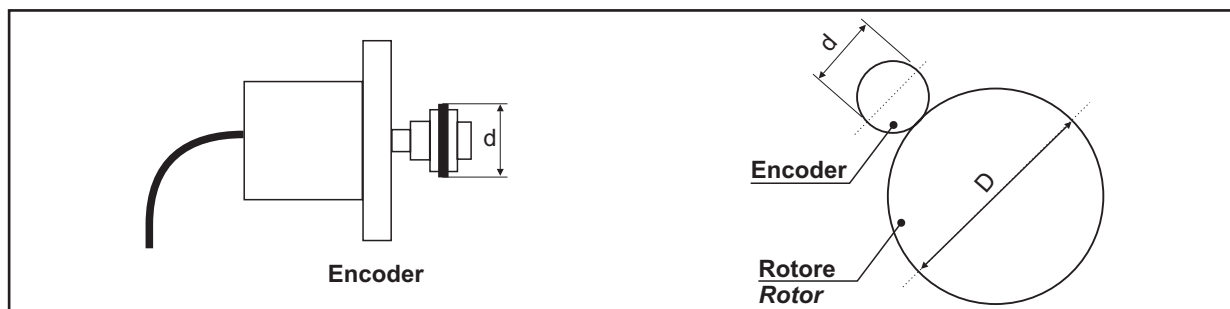

Tachometric encoders can be replaced with digital incremental encoders, to be positioned on the tangent, by appropriately configuring the parameters shown below.

Nota!

The motor setup uses the same procedure as for a standard brushless motor.

Menu	PAR	Description	UM	Type	FB BIT	Def	Min	Max	Acc	Mod
15.1	2100	Encoder pulses	ppr	UINT16		1024	128	16384	RWZ	FVS

Configure the plate value of the incremental encoder used.

Menu	PAR	Description	UM	Type	FB BIT	Def	Min	Max	Acc	Mod
15.9	2130	Encoder direction		ENUM		0	0	1	RWZ	F

The parameter must be configured to 0 or to 1 so that when the rotor turns clockwise the velocity reference value read at parameter 12210 is positive.

Menu	PAR	Description	UM	Type	FB BIT	Def	Min	Max	Acc	Mod
15.10	2132	Encoder mode		ENUM		Nessuna	CALCI	CALCI	ERWZ	FVS

The parameter must be configured to "Digital F" (value 2)

Menu	PAR	Description	UM	Type	FB BIT	Def	Min	Max	Acc	Mod
15.11	2136	PeripheralEncoder		BOOL		0	0	1	ERWZ	FVS

The parameter must be configured to 1.

Menu	PAR	Description	UM	Type	FB BIT	Def	Min	Max	Acc	Mod
15.13	2184	Ext Diam motor	mm	UINT16		1	1	65535	ERWZ	FVS

Configure the value of the external diameter of the motor rotor (D).

Menu	PAR	Description	UM	Type	FB BIT	Def	Min	Max	Acc	Mod
15.14	2186	Enc Pulley diam	mm	UINT16		1	1	65535	ERWZ	FVS

Configure the value of the diameter of the incremental encoder pulley (d).

Menu	PAR	Description	UM	Type	FB BIT	Def	Min	Max	Acc	Mod
21.16	4552	SpdRefLoss activity		ENUM		1	0	4	RW	FVS

The parameter must be set to "Disable" (option 2)

GEFRAN DEUTSCHLAND GMBH

Philipp-Reis-Straße 9a
D-63500 Seligenstadt
Ph. +49 (0) 61828090
Fax +49 (0) 6182809222
vertrieb@gefran.de

SIEI AREG - GERMANY

Gottlieb-Daimler Strasse 17/3
D-74385 - Pleidelsheim
Ph. +49 (0) 7144 897360
Fax +49 (0) 7144 8973697
info@sieiareg.de

SENSORMATE AG

Steigweg 8,
CH-83355 Aadorf, Switzerland
Ph. +41(0)52-2421818
Fax +41(0)52-3661884
http://www.sensorbate.ch

GEFRAN FRANCE SA

4, rue Jean Desparmet - BP 8237
69355 LYON Cedex 08
Ph. +33 (0) 478770300
Fax +33 (0) 478770320
commercial@gefran.fr

GEFRAN BENELUX NV

ENA 23 Zone 3, nr. 3910
Lammerdries-Zuid 14A
B-2250 OLEN
Ph. +32 (0) 14248181
Fax +32 (0) 14248180
info@gefran.be

GEFRAN UK LTD

Unit 7, Brook Business Centre
54a Cowley Mill Road, Uxbridge,
UB8 2FX
Ph. +44 (0) 8452 604555
Fax +44 (0) 8452 604556
sales@gefran.co.uk

GEFRAN MIDDLE EAST ELEKTRIK VE ELEKTRONIK SAN. VE TIC. LTD. STI

Yesilkoy Mah. Ataturk
Cad. No: 12/1 B1 Blok K:12
D: 389 Bakirkoy /Istanbul
TURKIYE
Ph. +90212 465 91 21
Fax +90212 465 91 22

GEFRAN SIEI

Drives Technology Co., Ltd
No. 1285, Beihe Road, Jiading
District, Shanghai, China 201807
Ph. +86 21 69169898
Fax +86 21 69169333
info@gefran.com.cn

GEFRAN SIEI - ASIA

31 Ubi Road 1
#02-07, Aztech Building,
Singapore 408694
Ph. +65 6 8418300
Fax +65 6 7428300
info@gefran.com.sg

GEFRAN INDIA

Survey No. 191/A/1,
Chinchwad Station Road,
Chinchwad,
Pune-411033, Maharashtra
Ph. +91 20 6614 6500
Fax +91 20 6614 6501
gefran.india@gefran.in

GEFRAN INC.

8 Lowell Avenue
WINCHESTER - MA 01890
Toll Free 1-888-888-4474
Fax +1 (781) 7291468
info.us@gefran.com

GEFRAN BRASIL

ELETROLETRÔNICA
Avenida Dr. Altino Arantes,
377 Vila Clementino
04042-032 SÃO PAULO - SP
Ph. +55 (0) 1155851133
Fax +55 (0) 1132974012
comercial@gefran.com.br

GEFRAN**GEFRAN S.p.A.**

Via Sebina 74
25050 Provaglio d'Iseo (BS) ITALY
Ph. +39 030 98881
Fax +39 030 9839063
info@gefran.com
www.gefran.com

Drive & Motion Control Unit

Via Carducci 24
21040 Gerenzano [VA] ITALY
Ph. +39 02 967601
Fax +39 02 9682653
infomotion@gefran.com

Technical Assistance :
techohelp@gefran.com

Customer Service :
motioncustomer@gefran.com
Ph. +39 02 96760500
Fax +39 02 96760278

Manuale ADL300 SYN FP -EN
Rev. 0.6 - 03-05-2016



1S9SEN