



LUXURY GRILL

Product Guide

A GRILL THAT HAS NO COMPROMISES







LUXURY GRILL

Specifications and Features

66,000 BTU

Featuring multiple cast stainless steel H burners with precision control and unprecedented power.

BEST IN CLASS ROTISSERIES

Premium whisper-quiet rotisserie is sourced by the worlds leading manufacturer. With a 25LB+ weight capacity, a fully ceramic burner and a proprietary non-electric ignition.

Innovative Flame Tamers

Our innovative design ensures even cooking and prevents unwanted flare ups.

LIMITLESS CAPACITY

Over 976 square inches of cooking surface, with 670 square inches of primary and 306 inches of top rack secondary

LASER CUT GRATES

Forged from a single piece of 5/16" 304 Grade Stainless Steel, Tereaux grates are without a doubt one of the ultimate options in the outdoor cooking industry.

MULTI ZONE CONTROL

With a heavy duty 9" foldable top rack and multiple cooking zones with removable dividers allow multi zone temperature control for the most seasoned grillers.



For more details on FAQ, installation, features, how to videos and questions, please scan this QR code for more product specific information or visit www.Tereaux.com and go to the product page.

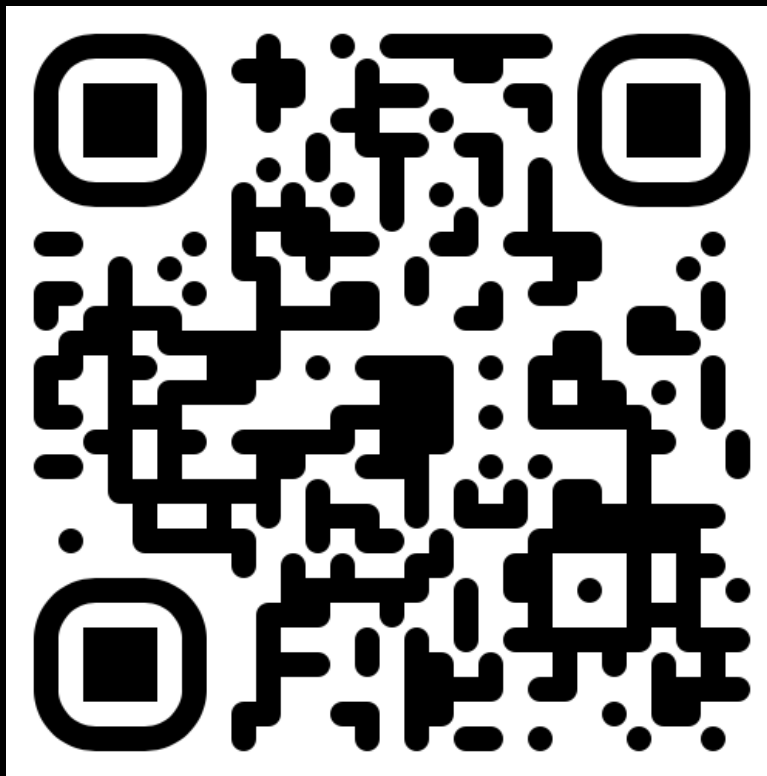

DESIGNED FOR A LIFE OUTDOORS

TERRA - *Earth*

EAUX - *Water*

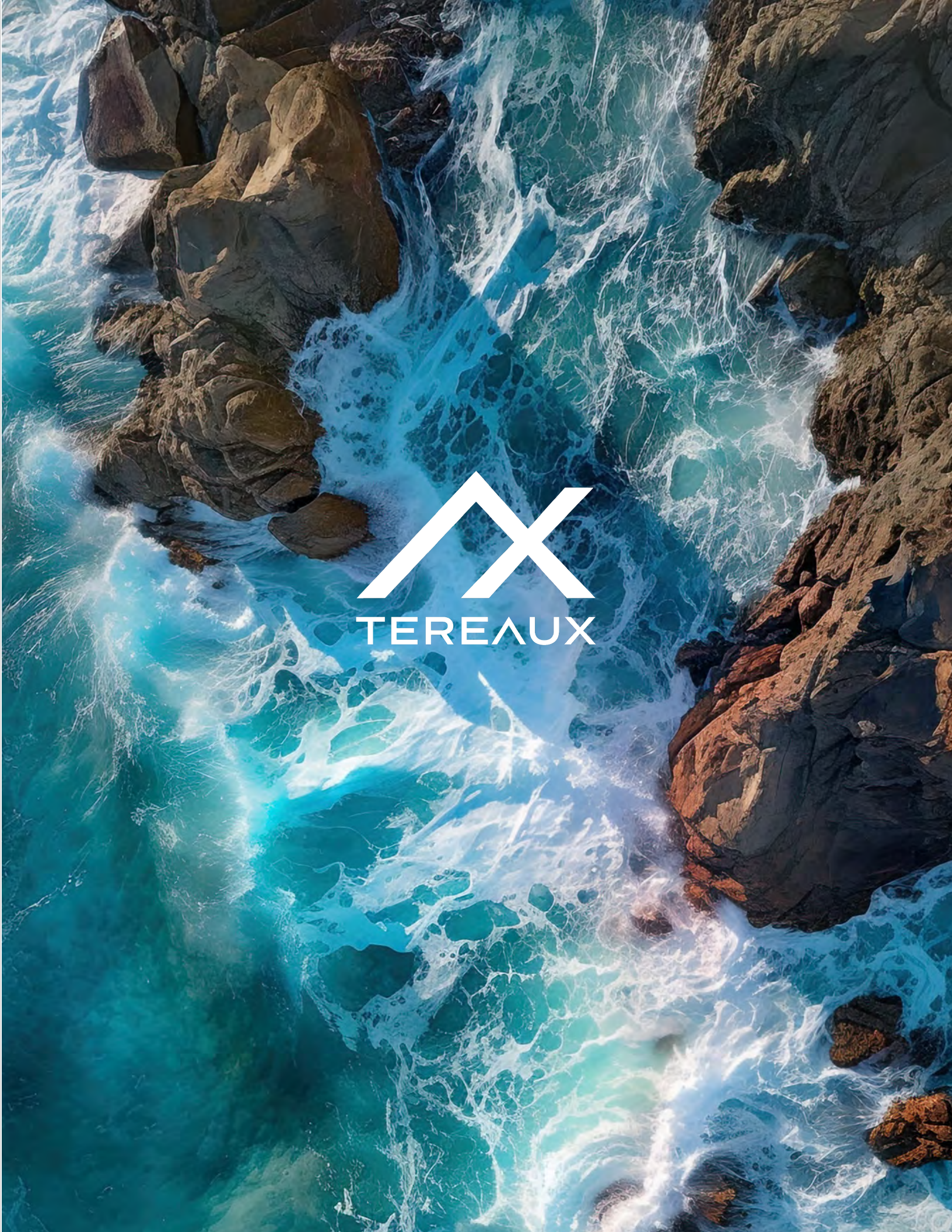

TEREAUX

TERRA/EARTH
EAUX/WATER





LASER CUT GRATES



**PREMIUM ROTISSERIE
FOLDABLE TOP RACK**



BUILT IN HOOKS



LED METAL KNOBS



CERAMIC ROTIS BURNER



**NO ELECTRICITY MATCH
LIGHT TECHNOLOGY**



**INTEGRATED TOWEL RACK
AND SPICE STORAGE**

LUXURY GRILL

SPECIFICATIONS AND FEATURES



**SOFT-CLOSE 304 STAINLESS
STEEL HINGES**



**PROFESSIONAL GRADE
ROTISSERIE PRONGS**

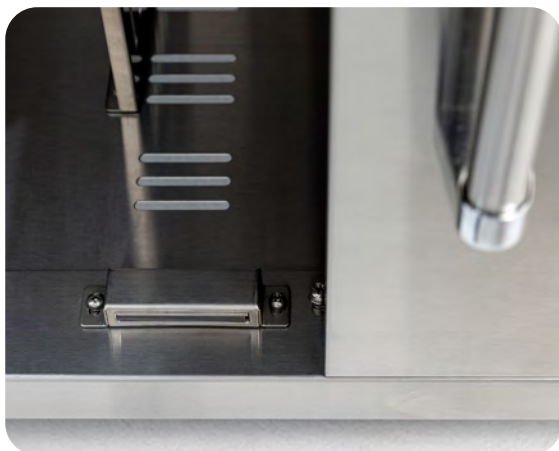

**PREMIUM MAGNETIC
CLOSURE SYSTEM**



**CONVENIENT
ROTISSERIE HOLDER**



**FORGED METAL
TEMPERATURE GAUGE**



**BUILT-IN
BOTTLE SERVICE**



**ULTRA-QUIET ROTISSERIE
MOTOR**

LUXURY GRILL

SPECIFICATIONS AND FEATURES

At Tereaux, we believe everything you need should be included in the box, with no extra trips or purchases required to set up your grill. The only thing your grill needs is an electrical and gas supply. This is a unique experience in luxury grills, where everything is an add-on. In the box we have included a regulator, a world-class rotisserie and even a grill cover for protection from the elements. Facilitating more time spent outdoors is our mission, so get outside and enjoy!

- Up to 66,000 BTUs
- Cast stainless steel Tereaux Signature Burners
- Full 304 stainless steel welded craftsmanship
- NEIT - Non-electronic ignition technology (ignites without electricity)
- Interior halogen flood-lighting
- LEDs illuminate the controls
- Forged Tereaux Signature temp gauge
- Spring-Loaded hood lifts effortlessly with soft-close
- Massive capacity - 976 sq. inches of cooking surface
- Multiple cooking zones with removable dividers
- Professional grade, 5/16" 304 stainless steel cooking grates
- 9" deep top rack provides baking and roasting area - folds up when not in use
- Reversible, flip to clean ceramic briquettes
- Attached premium bottle opener
- Grill cart has storage bays and integrated paper towel holder
- Heavy duty foldable side trays for transport and storage

DIMENSIONS

36 INCH GRILL W/CART

Width Open: 67"

Width Closed: 44 3/8"

Depth Open: 26 5/16"

Height Closed: 51 1/4"

Height Open: 60 1/2"

IMPORTANT NOTE:

CARTS ARE SHIPPED UNASSEMBLED IN A FLAT PACK. ASSEMBLY REQUIRES SIMPLE HAND TOOLS. TO LEARN MORE ABOUT ASSEMBLY PLEASE SCAN QR CODE ON FOLLOWING PAGE OR VISIT OUR WEBSITE.

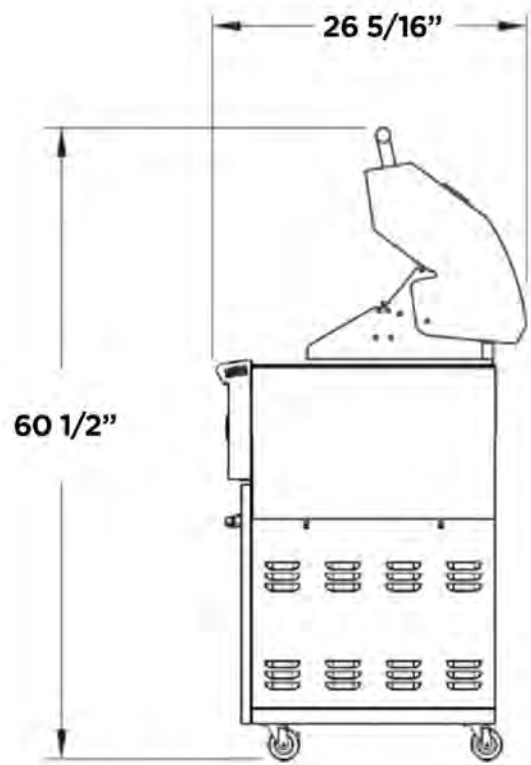

DIMENSIONS

30 INCH LUXURY GRILL

30 INCH LUXURY GRILL

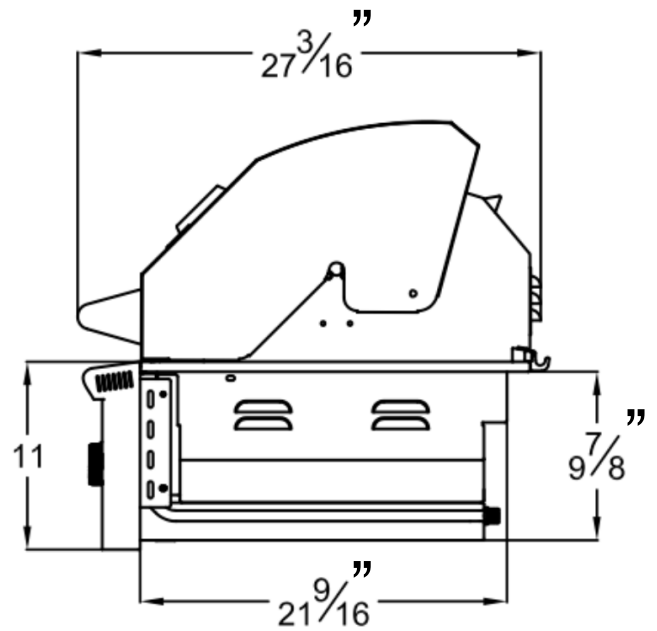
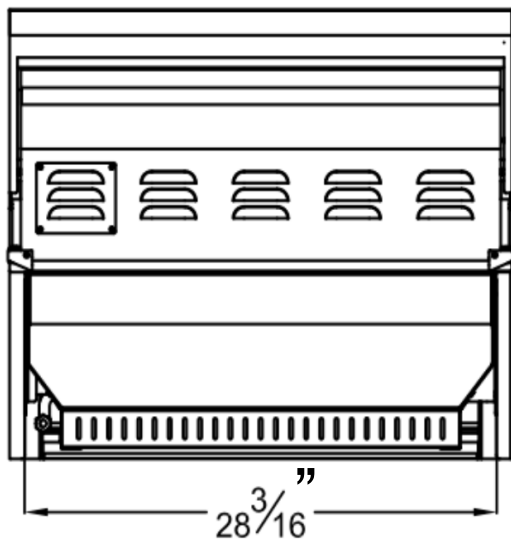
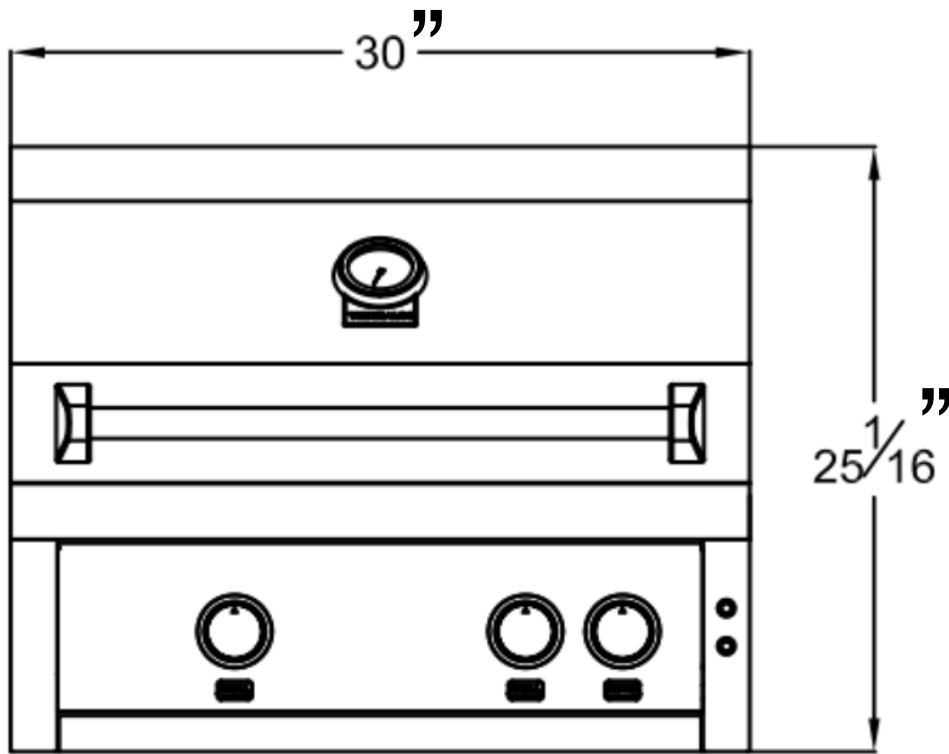

30 INCH LUXURY GRILL

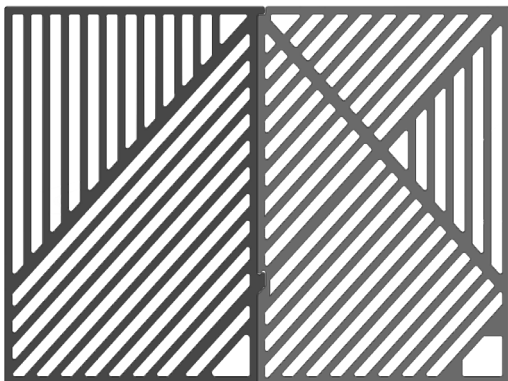
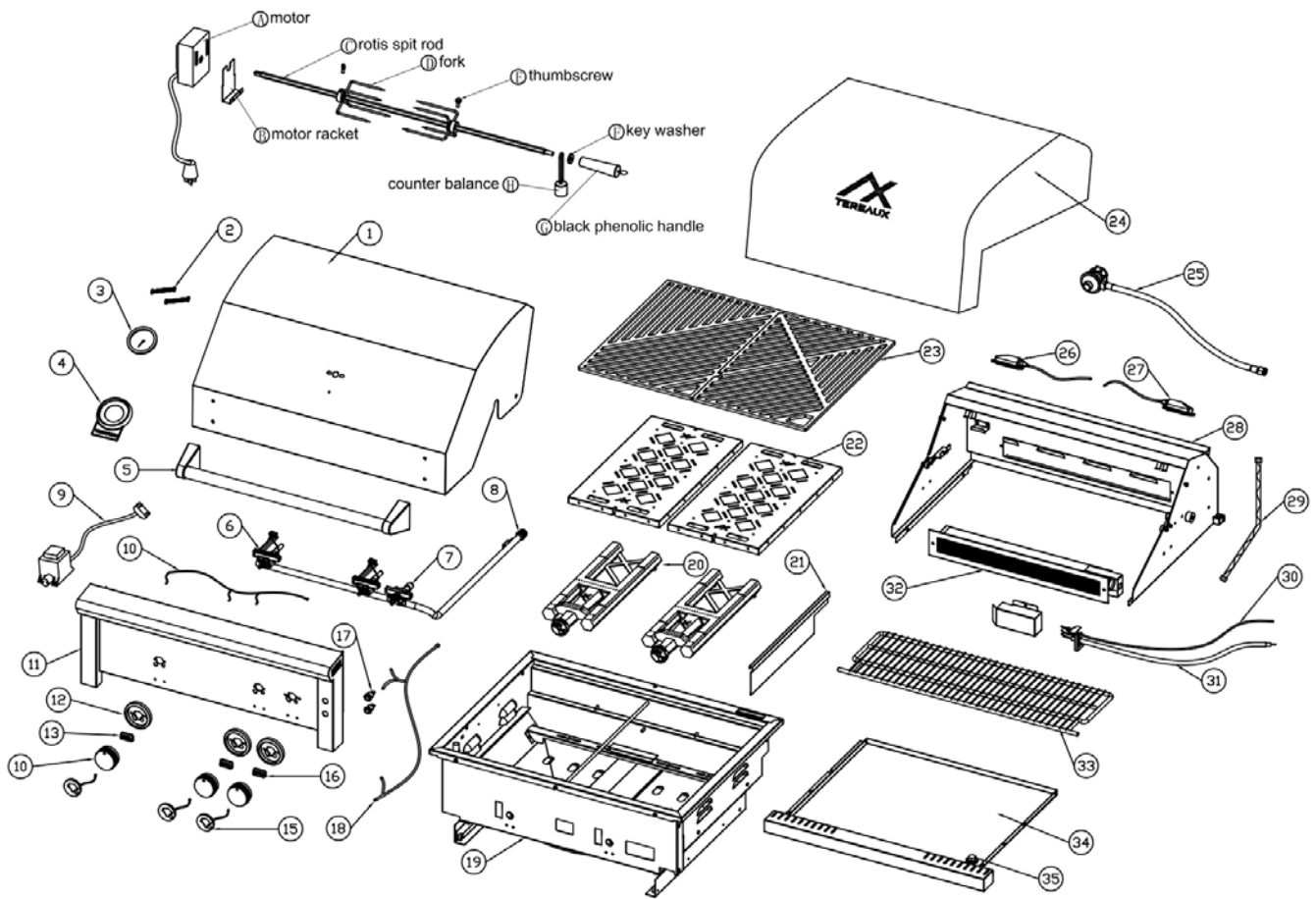

Featuring two professional grade, interlocking 5/16" 304 stainless steel cooking grates.

***Note orientation, grates designed to fit together as Tereaux logo**



DIMENSIONS

36 INCH LUXURY GRILL

36 INCH LUXURY GRILL

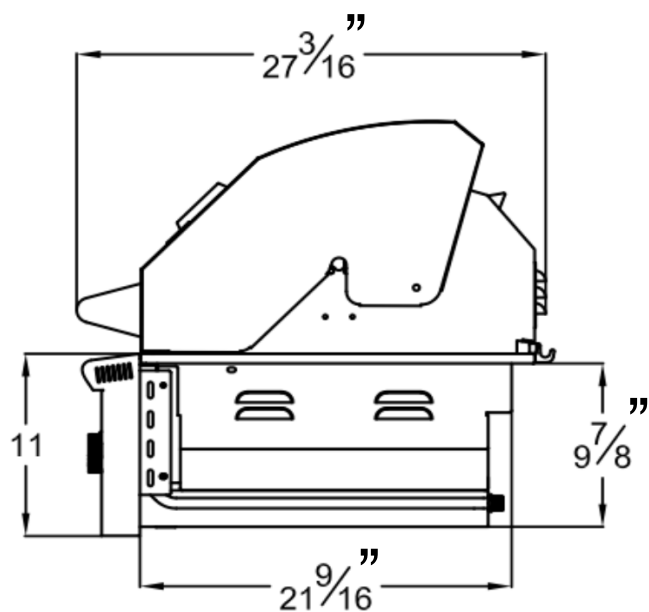
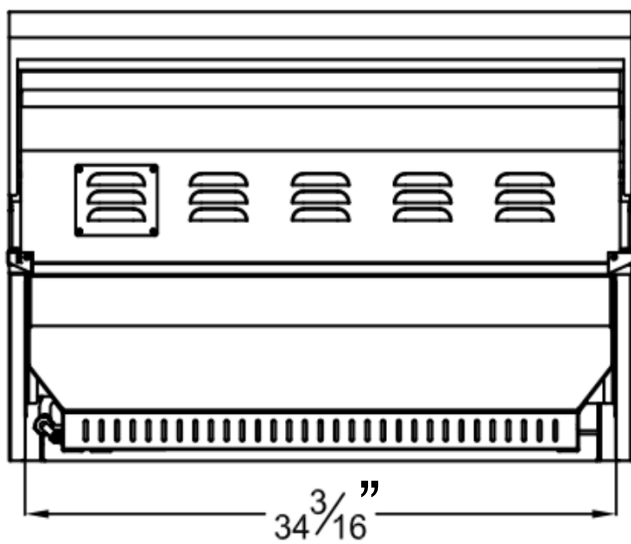
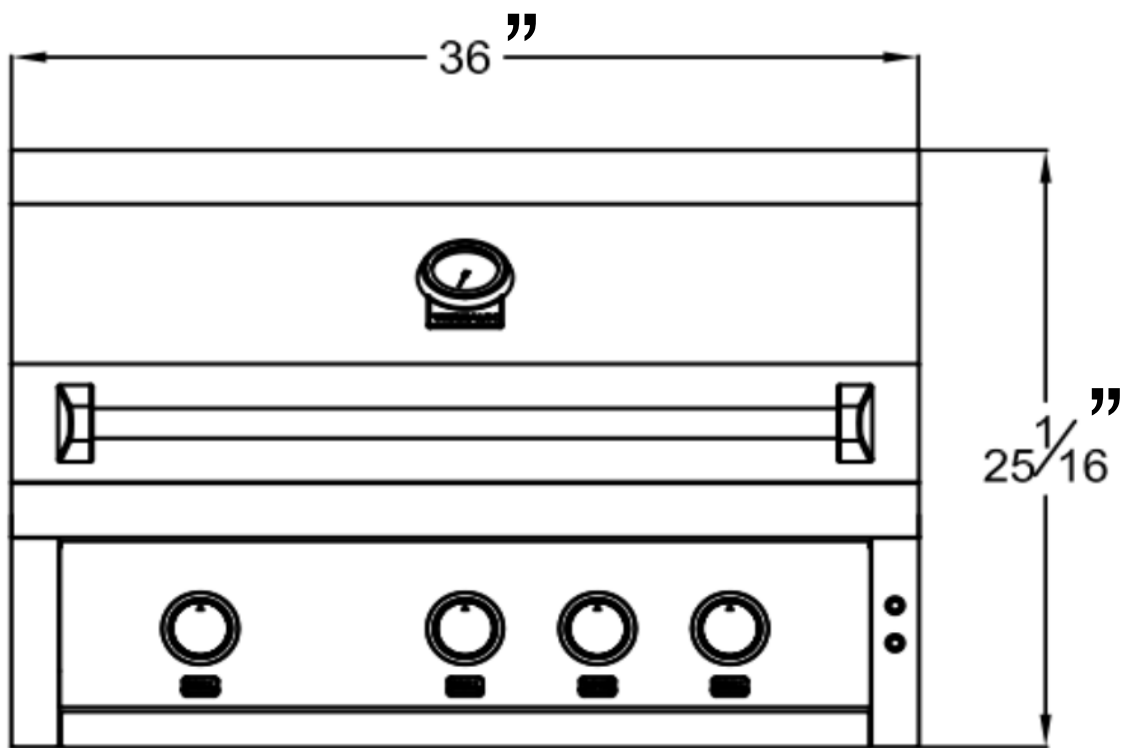

36 INCH LUXURY GRILL

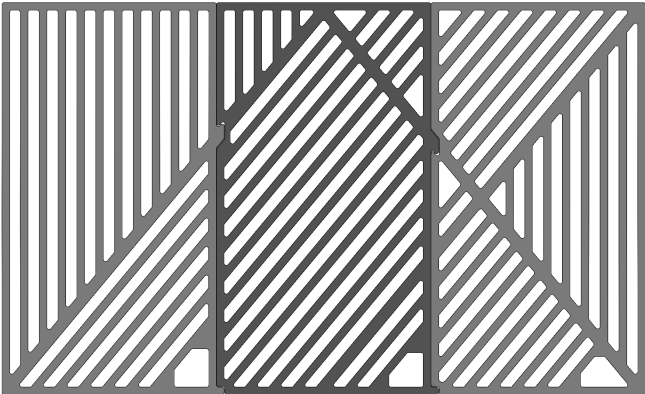
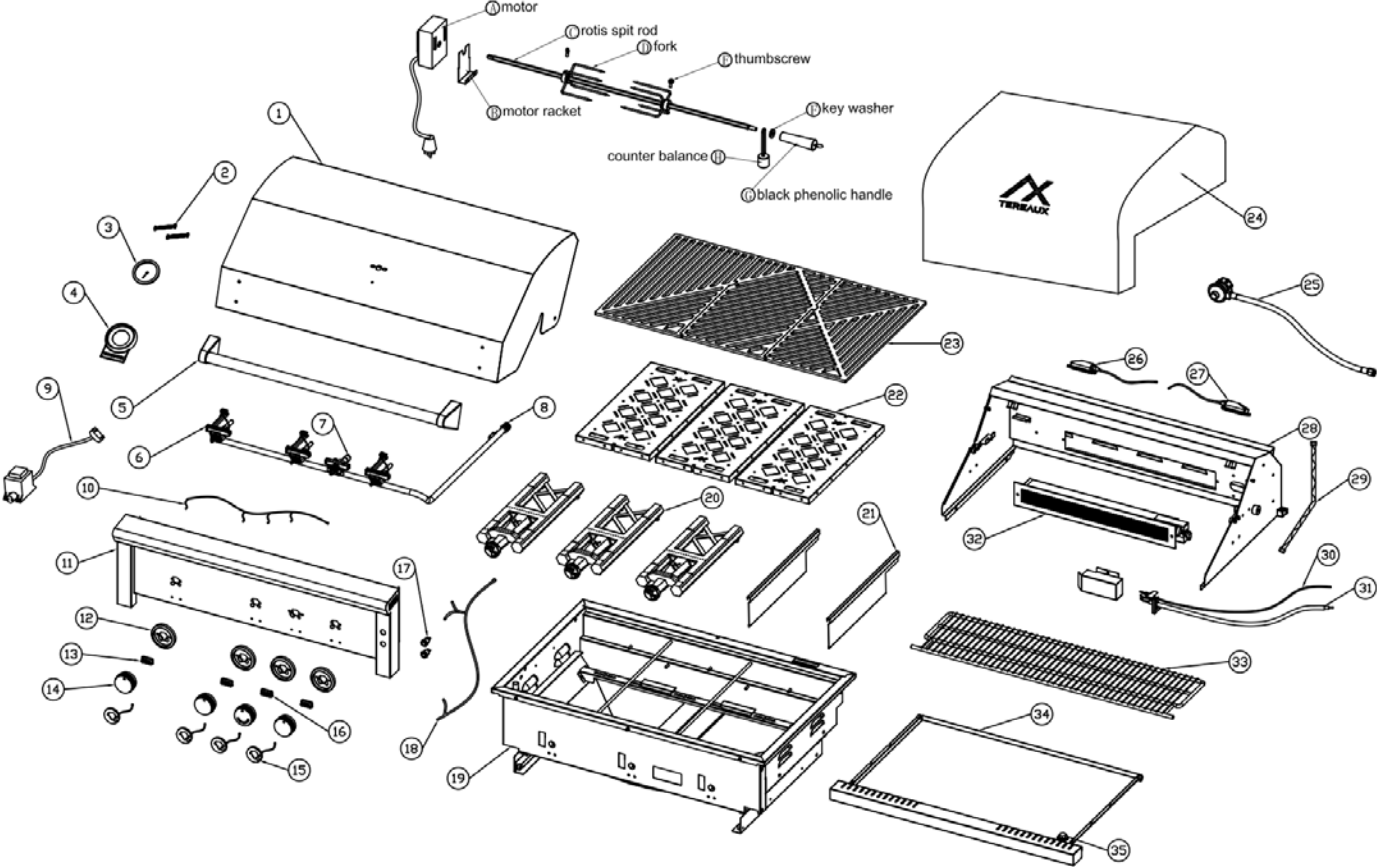

Featuring three professional grade, interlocking 5/16" 304 stainless steel cooking grates.

***Note orientation, grates designed to fit together as Tereaux logo**



DIMENSIONS

42 INCH LUXURY GRILL

42 INCH LUXURY GRILL

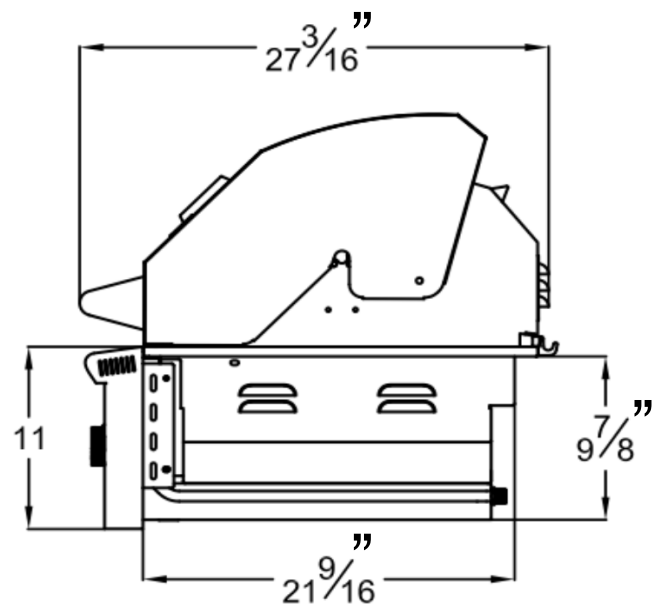
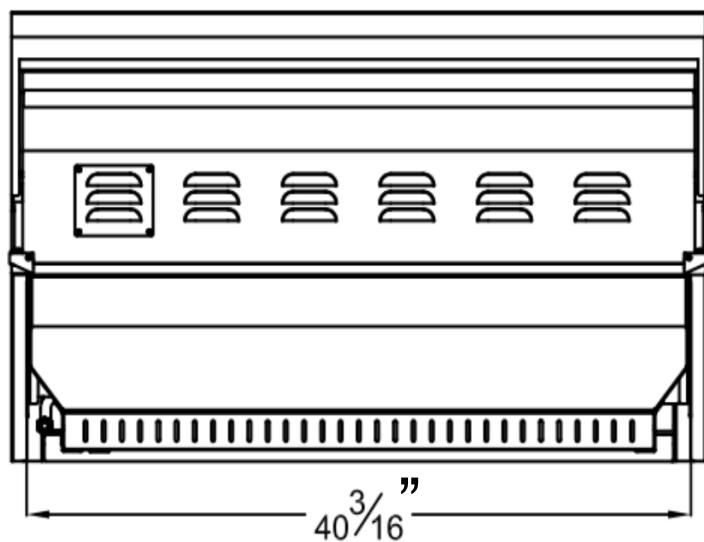
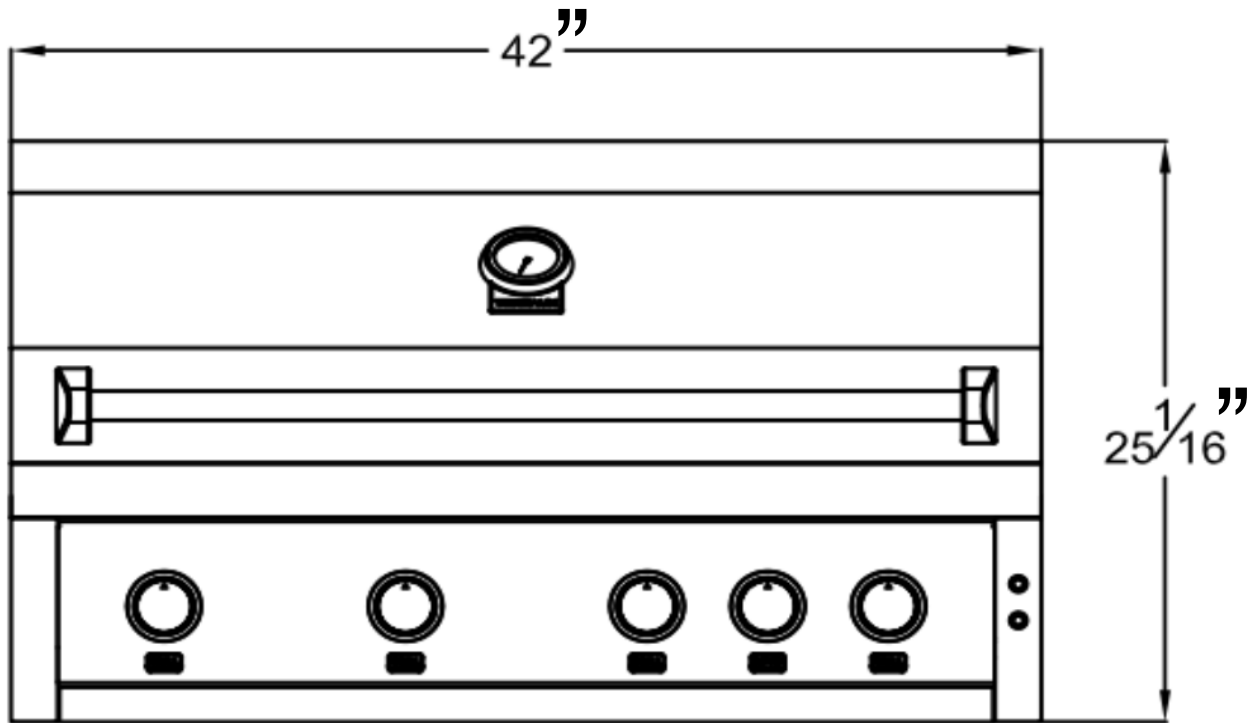

42 INCH LUXURY GRILL

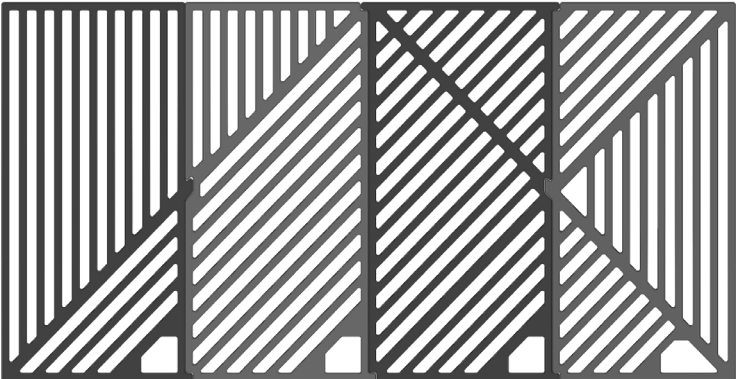
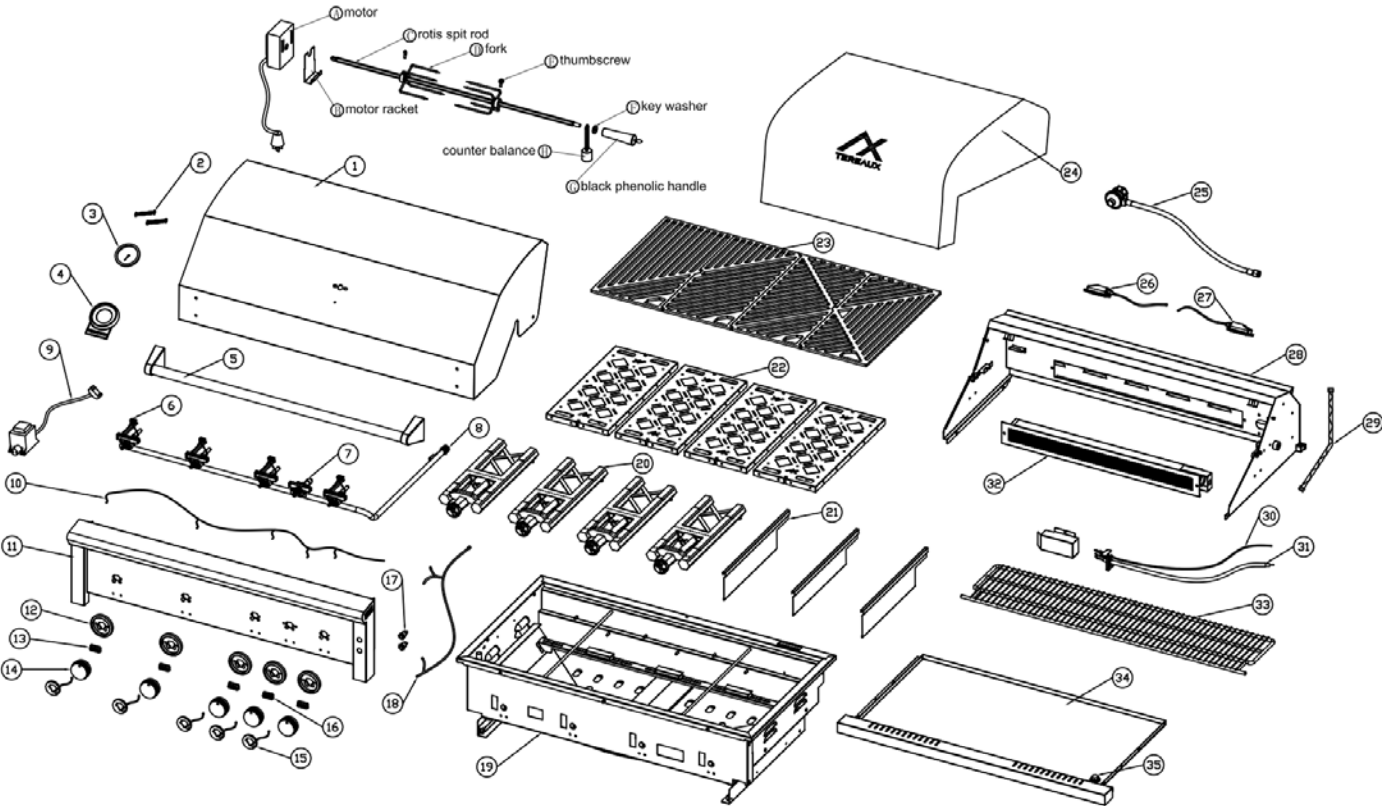

Featuring four professional grade, interlocking 5/16" 304 stainless steel cooking grates.

***Note orientation, grates designed to fit together as Tereaux logo**



PRODUCT INFO

PARTS KEY FOR BLOWOUT

Luxury Grill Blowout Diagram		NG Conversion Kit (Packaged in LP Grill)	
1	Hood	1	2.26 Main Burner Nozzle
2	Hood Spring	2	1.5 Rear Burner Nozzle
3	Temperature Gauge	3	Power Switch
4	Temperature Gauge Bezel	4	Halogen Lamp Bulb
5	Hood Handle		
6	Main Valve		
7	Rear Valve	LP Conversion Kith (Packaged in NG Grill)	
8	Gas Manifold		
9	60W Transformer	1	1.4 Main Burner Nozzle
10	LED Wire	2	1.1 Rear Burner Nozzle
11	Control Panel	3	Power Switch
12	Knob Bezel	4	Halogen Lamp Bulb
13	Grill Label	5	NG to LP Connector
14	Knob		
15	LED		
16	Rotis Label		
17	Power Switch		
18	Main Wire		
19	Firebox		
20	Main Burner		
21	Seperator Plate		
22	Ceramic Flame Tamer		
23	Cooking Grate		
24	Rain Cover		
25	LP Regulator		
26	Halogen Lamp (Long Wire)		
27	Halogen Lamp (Short Wire)		
28	Back Cover		
29	Corrugated Pipe		
30	Thermocouple		
31	Ignitor Pin		
32	Rear Burner		
33	Warming Rack		
34	Drip Tray		
35	Drip Tray Plug		

30INCH GRILL Circuit Diagram

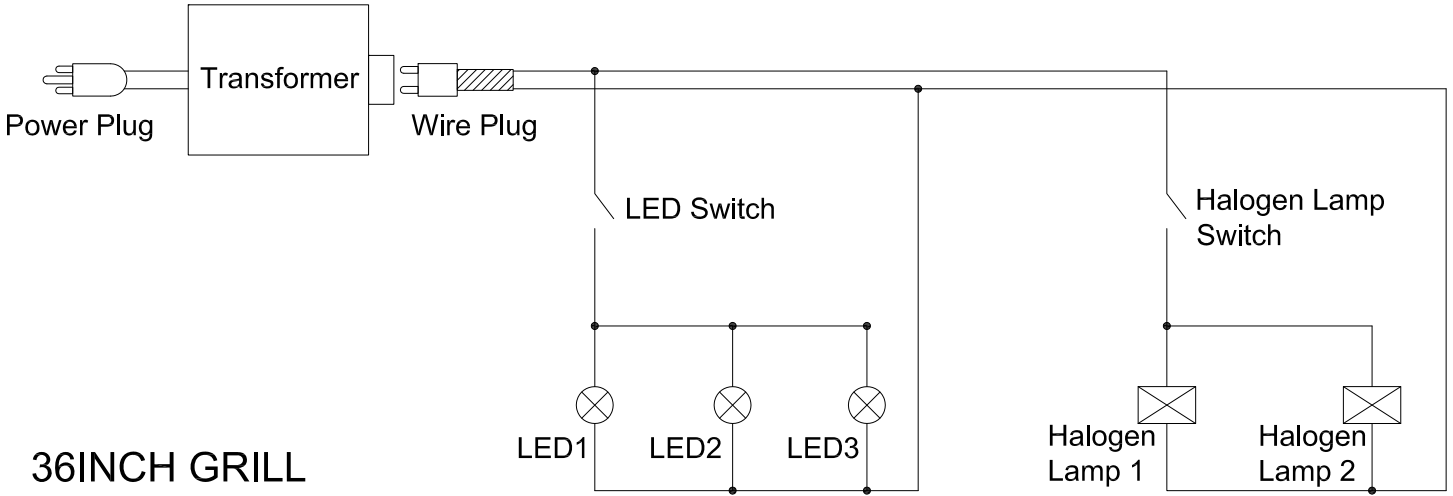

36INCH GRILL Circuit Diagram

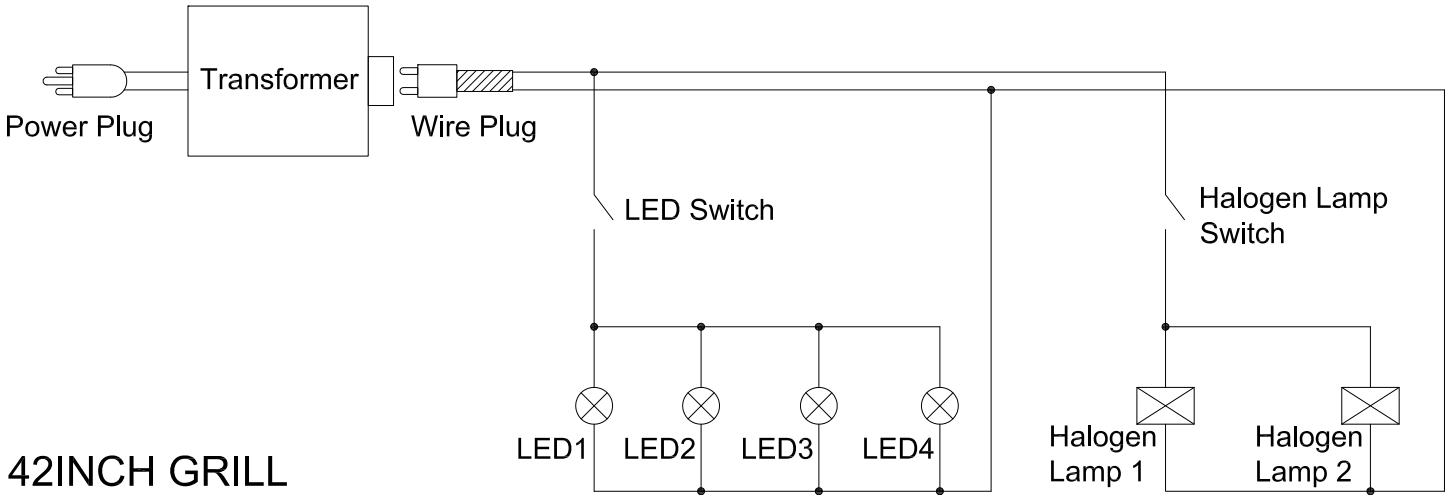

42INCH GRILL Circuit Diagram

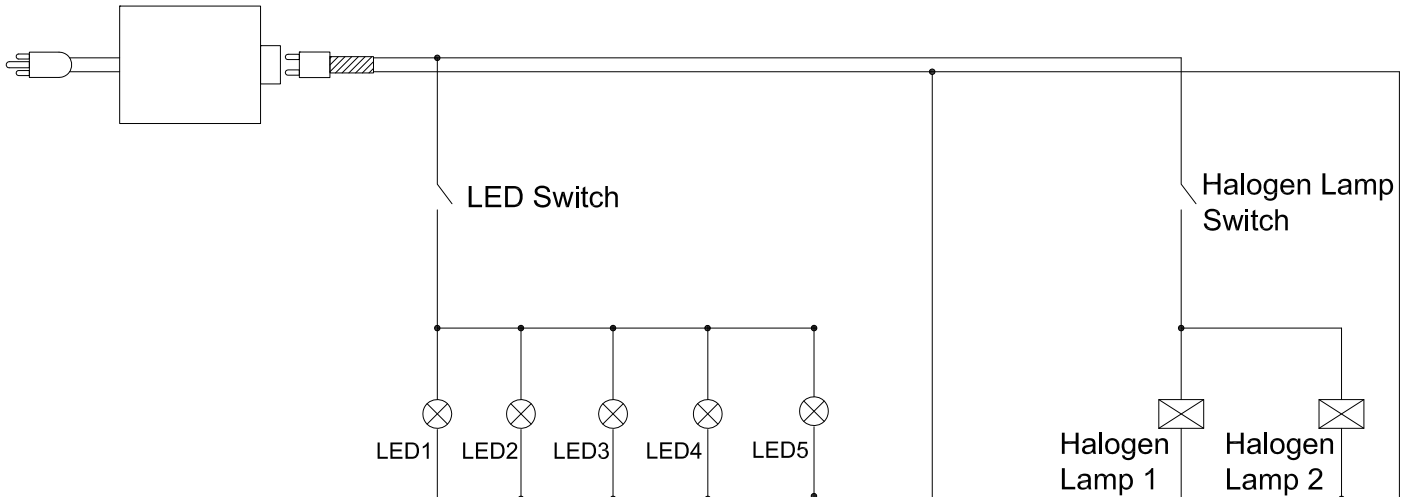

For more details on registration, installation, features, how to videos and questions, please scan this QR code for more product specific information or visit www.Tereaux.com and go to the product page.

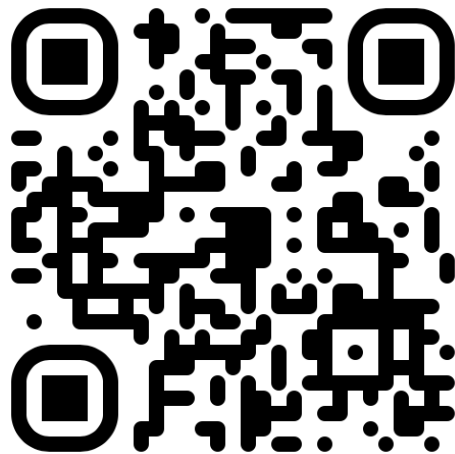

WWW.TEREAUX.COM



ALL GRILLS, INCLUDING YOUR TEREAX GRILL, PRODUCE SIGNIFICANT HEAT AND HAVE OPEN FLAMES AND ARE INHERENTLY DANGEROUS, AND THEIR USE CAN RESULT IN SERIOUS INJURY OR DEATH. GIVEN THESE RISKS, YOU MUST PROPERLY ASSEMBLE, INSTALL, MAINTAIN AND USE YOUR TEREAX GRILL. AND, IF YOU FOLLOW SAFE AND PROPER PRACTICES, YOUR TEREAX GRILL WILL PROVIDE YOU WITH YEARS OF LUXURIOUS OUTDOOR COOKING. OTHER SECTIONS OF THIS MANUAL PROVIDE NUMEROUS DETAILS THAT ARE IMPORTANT FOR YOUR SAFE AND PROPER ASSEMBLY, INSTALLATION, MAINTENANCE AND USE OF YOUR TEREAX GRILL. THE NEXT FEW PAGES INCLUDE SOME SUMMARY POINTS FROM THESE SECTIONS TO SERVE AS A REMINDER OF SOME BASIC ITEMS FOR YOUR SAFE AND PROPER ASSEMBLY, INSTALLATION, MAINTENANCE AND USE OF YOUR TEREAX GRILL. IF YOU EVER HAVE ANY QUESTIONS ON YOUR TEREAX GRILL, PLEASE CONTACT OUR CUSTOMER SERVICE AS WE ARE HERE TO HELP.

THIS MANUAL CONTAINS IMPORTANT INFORMATION ON YOUR TEREAX GRILL AND ITS ASSEMBLY, INSTALLATION, CARE AND USE. THIS MANUAL SHOULD BE REVIEWED CAREFULLY AND ENTIRELY BEFORE ASSEMBLY, INSTALLATION AND USE, AND YOU SHOULD RETAIN THIS MANUAL FOR FUTURE REFERENCE.



REMINDERS

SAFE AND PROPER USE

PAY ATTENTION TO YOUR GRILL AND WHO IS AROUND IT

- Never leave the grill unattended while cooking
- Do not leave children unattended around the grill, or allow children to use the grill
- Some grill surfaces will be hot, so do not allow children to be around the grill unsupervised or to play around the grill. The grill cabinet is for storage of grilling accessories, not for storage of children's toys and not a place to play in. Keep all children away from the grill.

DO NOT OPERATE YOUR GRILL IF YOUR CONDITION OR YOUR SURROUNDINGS DO NOT ALLOW FOR SAFE OPERATION

- Never operate the grill while under the influence of alcohol or drugs;
- Never use the grill in windy conditions;
- Only use the grill outside in a well-ventilated area, and not in any enclosed area or close to any flammable materials;
- Do not have any trash or flammable materials, like lighter fluid, near the grill;
- Ensure that the heat and vapors from the grill have sufficient room to ventilate;
- Ensure that you have a fire extinguisher such as type A:B:C or K in close proximity while grilling, and remember that certain fires (like grease fires) cannot be extinguished with water.

GRILLS ARE EXTREMELY HOT AND HAVE OPEN FLAMES

- Many of the parts of the grill will become extremely hot while in use, do not touch any areas of the grill other than the handle, operational knobs and other cool parts. Contacting hot surfaces will result in burns.
- When grilling protect your hands and other body parts and use appropriate heat-resistant gloves and utensils for operating the grill and touching grates or other hot parts or moving food. Wear appropriate clothing while grilling. Loose, synthetic or similar clothing poses the risk of catching on fire;
- Keep towels, potholders and other items that are flammable away from the grill. Parts of the grill will be hot, so these items may ignite or cause injury. Wet items used with the grill could also result in steam burns;
- A glove should be used to open the hood by way of the handle, and the hood should always be opened slowly to reduce the risk of flare-ups, burns or heat escaping. When checking food, ensure that you remain a safe distance from the hood opening and grilling surface;
- Do not move, store, or cover a hot grill, wait for it to cool completely or you may be burned. If storing in a garage or unventilated area, close and remove the propane tank and store that outdoors in a ventilated, protected area. Always use a cover when storing.
- Do not heat sealed containers as they will explode.
- You should not use foil to cover any or all of the grates - however foil packets are okay. Do not remove the drip tray or otherwise alter the operation of the grill. Impacting the safe and proper operation of the grill as designed can result in fires, melted parts or injury and death.
- The fats, oils and grease that result from grilling are highly flammable and could result in flare-ups and damage to the grill, which will not be covered by our warranty. Care should be taken to ensure

safe operation and prevent flare-ups and fires on or within the grill, and the drip tray must be regularly cleaned when the grill is cool.

- Pellets, wood chips and similar products should only be used within our smoker box that is sold separately from the grill. Use of these flammable items outside of the smoker box will result in fires and damage to the grill. No damage from improper use will be covered by our warranty.
- Ensure that any pans, bowls or other cookware are suitable for use on a grill and the temperatures that the grill can reach. Many glass, pyrex, ceramic and similar cookware cannot withstand grilling temperatures and will crack, shatter, and/or explode, resulting in potential injury or death.

GAS IS HIGHLY FLAMMABLE, ASSEMBLE, INSPECT AND USE WITH CARE

- Ensure that you know how to connect, disconnect and turn off any gas supply to the grill prior to use, and that the gas supply is not damaged in any way. Any hoses, tubes or cords should be located in a place where they are not exposed to heat or open flames.
- Prior to each use, you should inspect the grill for obstructions to the gas flow and damage to the gas tubes and hoses, and to ensure that the gas ports on the burners are clean. Rodents and insects can damage or leave materials in a grill that disrupts gas flow and can cause flames and fires within the grill structure. All inspections should be done with the gas supply off.
- Inspect your grill and the gas regulator, hoses, tubes, burners and other parts at least several times per year and after any period where you have not regularly used the grill. Inspection of the gas parts should include spraying with a mild soap and water solution and observing whether any bubbles appear. If there is a leak, or you smell gas, shut off the gas supply and discontinue use until resolved. Never inspect your grill or the gas parts using a lighter or open flame. Inspect also for corrosion, cracks or other damage. Routine care and maintenance should be performed at least several times per year and potentially more often depending on your location.
- After any inspection, if there is any problem or issue with your grill, do not use the grill until the problem or issue is resolved and contact customer service promptly. Any repairs to your grill should be performed only pursuant to our express instructions or by an authorized retailer or technician.
- The grill hood must be open when lighting a burner to prevent a buildup of gas and an explosion when lit. Do not look into or over the grill surface when lighting. If there are problems lighting, or the grill extinguishes during operation, turn off the gas control knobs, leave the hood open and allow the grill to adequately ventilate prior to lighting again.
- When you are done grilling, all controls should be turned off and the grates should be cleaned while hot with a wire brush. Since the grill is hot, ensure that you are careful not to contact any parts and are using a grill mitt when using water or any liquid to clean as that will result in steam, which may cause burns and injuries. Some cleaning products can result in vapors or may ignite on hot surfaces, please ensure that you are using appropriate cleaning products and not using these while grill is hot.
- When you are done grilling and after the grill has cooled, close the gas supply and clean the remainder of grill as needed.

When properly cared for, your Tereaux product will provide safe, reliable service for many years. Extreme care must be used as the grill produces heat, which can cause serious injury or even death if the instructions are not followed. When using this product, basic safety practices must be followed.

REGULATORY

CODE REQUIREMENTS

Installation of your Tereaux grill needs to be made in compliance with all state and local codes and regulations, including any building requirement. If your location does not have these codes, your Tereaux grill should be installed in accordance with national codes and generally accepted construction practices, including, without limitation, the National Fuel Gas Code ANSI Z223.1/NFPA 54, Natural Gas and Propane Installation code CSA B149.1, Propane Storage and Handling Code B149.2, and National Electrical Code ANSI/NFPA 70, or Canadian Electrical code CSA C22.1.

STATE OF MASSACHUSETTS

Massachusetts requires all gas be installed using a plumber or gas fitter carrying the appropriate Massachusetts license. All permanently installed natural gas or propane installations require a T handle type manual gas valve be installed in the gas supply line to this appliance. This does not apply to portable propane installations using a 20lb. cylinder.

CALIFORNIA PROPOSITION 65 - WARNING

WARNING: This product can expose you to chemicals including carbon monoxide, which is known to the State of California to cause birth defects and other reproductive harm. For more information, go to www.P65Warnings.ca.gov.

Use a 20 lb. liquid propane (LP) gas cylinder - 12.25" diam. X 18.25" H (31cm X 47cm) which features an Overfill Protection Device. The cylinder must be installed in the upright position. Do not use a dented or rusty LP cylinder as it may be hazardous and should be checked by your LP supplier. Never use a cylinder with a damaged valve. Don't alter the gas fittings. Check the expiration date on the cylinder collar as well. Do not refill an expired cylinder, it must be replaced. If you buy refilled (exchange) LP cylinders, check this date as well. The LP gas cylinder must be constructed and marked in accordance with the specifications for LP gas cylinders of the U.S. Department of Transportation (DOT). The cylinder must be provided with a shut off valve terminating in an LP gas supply cylinder valve outlet specified, as applicable, for connection type QCC1 in the standard for compressed gas cylinder valve outlet and inlet connections ANSI/CGA-V-I. Certain liquid propane dealers may fill LP cylinders for use in the grill beyond cylinder filling capacity. This "overfilling" may create a dangerous condition due to a build-up of excess pressure. As a safety device, there is a pressure relief valve which will vent propane gas vapor to relieve this excess pressure. This vapor is combustible and therefore can be ignited. Make sure to follow the following:

1. When filling your cylinder, tell the supplier to fill it to no more than 80% of its total capacity.
 2. If you use a spare cylinder, you should not store it near or under the grill/cart unit or burner box, or near any other ignition or heat source (like a water heater or furnace).
- IF THE INFORMATION IN 1 AND 2 ABOVE IS NOT FOLLOWED EXACTLY, A FIRE CAUSING DEATH OR SERIOUS INJURY MAY OCCUR.
3. The LP cylinder must be disconnected and stored OUTSIDE in a well-ventilated area, out of the reach of children.
 4. Do not store a full cylinder in direct sunlight.
 5. Turn off the LP supply at the cylinder when the appliance is not in use.

COOKING TIPS AND SUGGESTIONS

To achieve the perfect steak at varying levels of temperatures, precision and finesse are imperative. Here's how to elevate your steak game:

For Rare and Medium Rare Steaks:

1. Preheat your grill to an impressive 500°F (260°C) to ensure a swift and precise sear.
2. Season your steak judiciously with a delicate blend of sea salt and freshly ground black pepper.
3. Gently lay the steak on the grill, allowing it to sear for 2-3 minutes per side for rare, and 3-4 minutes per side for medium rare.
4. Remove from direct heat to finish cooking.
5. Employ a meat thermometer to ascertain an internal temperature of 125°F (52°C) for rare and 135°F (57°C) for medium rare.
6. Following its removal from the grill, allow the steak to luxuriate in a brief respite of 5-10 minutes, permitting the redistribution of succulent juices before carving.

For Medium, Medium Well, and Well Done Steaks:

1. The grill should be preheated to an exacting 450°F (232°C), ensuring a controlled and nuanced cooking environment.
2. Adorn your steak with a meticulous seasoning of artisanal sea salt and a bespoke blend of freshly cracked peppercorns.
3. Place the steak on the grill, attending to its transformation over 4-5 minutes per side for medium, 5-6 minutes per side for medium well, and 6-7 minutes per side for well done.
4. Remove from direct heat to finish cooking.
5. Employing the precision of a meat thermometer, confirm internal temperatures of 145°F (63°C) for medium, 150°F (66°C) for medium well, and 160°F (71°C) for well done.
6. To culminate this gastronomic journey, permit the steak to rest for 5-10 minutes, allowing for a symphony of flavors to harmonize before presentation.

Meticulous execution, attention to detail, and a profound understanding of the nuances of temperature are essential to ensure an exemplary dining experience at each level of doneness.

INSTALLATION

Install using Non-Combustible Construction and Materials only

A minimum of 6" clearance from the back of your Tereaux grill to any objects or materials is required to allow the hood to operate and to provide clearance. Clearance from the sides of the grill is not needed if adjacent construction and materials are to construction. ALL materials into which your Tereaux grill is installed and all adjacent objects and materials (ie countertops) must be non-combustible.

ISLAND VENTILATION OPENINGS

All islands and other built in applications should have ventilation holes to prevent gas build-up in the event of a leak. (See ANSI Z21.58 Standard for Outdoor Cooking Gas Appliances, Section 4.6 Enclosures For Self Contained LP-Gas Supply Systems f

For an enclosure having four sides, a top and a bottom:

1. At least two ventilation openings shall be provided in the side walls of the enclosure, located within 5" [12.7cm] of the top of the enclosure, equally sized, placed on two adjacent sides, and unobstructed. The opening(s) shall have a total free area of not less than 10 square inches for each 20lb cylinder tank stored.
2. Ventilation opening(s) shall be provided at floor level of the enclosure and shall have a total free area of not less than 10 square inches for each 20 lb cylinder tank. If ventilation opening at floor level are in a side wall, there shall be at least two openings. The bottom of the openings shall be 1" [2.54cm] or less from the floor level and the upper edge no more than 5" [12.7cm] above the floor level. The openings shall be equally sized, placed on two adjacent sides and unobstructed.
3. Every opening shall have minimum dimensions so as to permit the entrance of a 1/8in [.31cm] diameter rod.



DANGER

Damage caused from use in windy conditions, such as melted knobs and/or wiring, discoloration of the control panel, etc., is excluded from warranty coverage.

STAINLESS STEEL CARE

Stainless Steel is widely used for catering and residential kitchen equipment because of its strength, its ability to resist corrosion, and its ease of cleaning. Unfortunately, the metal is often taken for granted and it is assumed that no problems will arise during its usage. However, some care is required to ensure a long service life of the grill.

To maintain the original appearance of your Tereaux grill, a regular cleaning routine should be carried out using the following guidelines:

1. After use, following the safety precautions detailed earlier in this manual, wipe the grill with a soft, damp, soapy cloth and rinse with clean, warm water. This should remove most substances encountered during the grilling process.
2. For stubborn stains, including burnt-on grease and food-borne deposits, use a multipurpose,
3. non- abrasive, cream cleanser and apply with a soft damp cloth. Rinse with fresh water, as described above. On no account should steel wool pads be used unless they are made of stainless steel.
4. Harsh abrasives and metallic scouring materials should not be used for cleaning stainless steel as they will leave scratch marks in the surface and damage the appearance of the grill. Likewise, do not use wire brushes, scrapers or contaminated scouring pads.
5. For those areas with a directional grain, any cleaning with abrasives should be carried out along this grain direction and not across it.
6. After use, always remove wet cleaning aids (such as cloths, pads, containers) from the surface, to avoid formation of water marks or stains.
7. If required, dry the grill after use with a soft dry cloth or towel.

If the preceding guidelines are adhered to, your Tereaux grill should offer excellent life and should live up to its reputation of being “stainless”. Neglect of this practice, however, can lead to deterioration of the surface and, in some extreme cases, corrosion of the steel itself. The two most common types of corrosion that may be encountered, particularly on stainless steel, are rust marks and pitting of the surface.

RUST-BROWN MARKS

These rust marks are likely the result of small particles of “ordinary-steel” which have become attached to the surface and have subsequently rusted in the damp environment. The most common source of such particles is from steel wool scouring pads, but contamination may also occur from carbon steel utensils and water from old supply pipes. These brown marks are only superficial stains which will not harm the grill. They should be removable using a soft damp cloth and a multi-purpose, non-abrasive, cream cleanser. Occasionally, it may be necessary to resort to a proprietary stainless steel cleanser to return the surface of the grill to its original condition. To avoid re-occurrence of any “rust-staining”, it is essential that the source of the contamination is eliminated. A Tereaux grill cover will go a long way toward preventing this kind of contamination.

PITTING

A more severe form of corrosion is pitting of the surface. The sources of this corrosive attack can usually be attributed to certain household products such as bleach, household cleaners containing bleach (sodium hypochlorite), and pool chlorine. If you see pitting of the stainless steel surface, you can attempt to buff it out using stainless steel abrasive pads, but in most cases, pitting of the surface cannot be removed.

FOODSTUFFS

In general, stainless steel is fully resistant to all foodstuffs in common use. Only in isolated cases, such as when concentrated salt and vinegar mixtures are allowed to remain in contact with the steel for a prolonged period, can any surface marking result. Clean the surface as per instructions above.

SALT WATER ENVIRONMENTS

Exposure to salt air and spray may cause surface rust or staining to appear. If neglected, pitting and severe corrosion on various parts of your grill will occur. Clean the surfaces as per instructions above on a more frequent basis, perhaps every week or every other week, and maintain the unit covered. The Tereaux warranty does not cover occasional surface rust or staining due to environmental conditions. See warranty section for details.

CLEANING AND MAINTENANCE

Tereaux grills are available in standard stainless steel, or 11 optional colors. The tough powder-coating on these panels are commonly used on automotive parts, and commercial and residential appliances because of their excellent chip resistance, and resistance to a variety of chemicals. The finish should hold up well outdoors in most conditions. However, like any painted surface, special care must be taken when cleaning this finish.

To clean your powder coated surface:

1. Carefully remove any loose deposits with a wet sponge.
2. Use a soft brush (non abrasive) or cloth, and a mild household detergent solution to remove dust, salt and other deposits. Never use any solvent-based cleaners, stainless steel cleaners, heavy degreasers, oven cleaners, etc. on the painted surfaces. They can permanently damage the paint.
3. Rinse off with clean fresh water and dry with a clean cloth.

CARE AND MAINTENANCE OF GRILL COMPONENTS

GRILL GRATE AND WARMING RACK

The easiest way to clean the cooking grates is immediately after cooking is completed and after turning off the flame. Wear a grill mitt to protect your hand from the heat and steam. Dip a brass bristle grill brush in hot soapy water and scrub the hot grill rack. Dip the brush frequently in the bowl of water. The steam created as water contacts the hot grill, assists the cleaning process by softening any food particles. The food particles will fall through the grates and burn. If the grill is allowed to cool before cleaning, then cleaning will be more difficult.

DRIP TRAY

The drip tray should be cleaned after every usage of the grill. Leaving a dirty drip tray in place will attract insects and rodents. After allowing the grill to cool completely, remove the drip tray by pulling it out of the grill. After cleaning, reinstall the tray.

GRILL BURNERS

The briquette radiant trays should protect the Tereaux Signature H Burners completely. However, it may become necessary to clean the burners, or to clean the firebox beneath the burners. Before removal, make sure the gas supply is OFF and the control knobs are in the OFF position. Allow the grill to cool completely, then lift off the cooking grates and radiant trays. To remove burners, lift the rear of the burner out of the hanger bracket slightly, then rotate the burner to the left slightly to clear the igniter shroud at the front of the firebox, then move the burner toward the rear of the firebox until it is out. The burner is made out of a high-grade, 300-series stainless steel which can be cleaned with a brass-bristle brush and warm, soapy water. Do not clean the ports with a toothpick or other item which may break off inside the port. Use a paperclip or needle to do this. Stubborn scale can be removed

with a metal scraper. Be sure to rinse everything well and shake out any water and debris trapped inside the burner tube.

Great care should be used when re-installing the burner. It must be correctly centered and secured on the orifice before any attempt is made to relight the grill. The rear burner bracket should lie flat and not have any side-to-side movement. See the LOCATING AND ASSEMBLING THE GRILL section of this manual for details on proper burner installation.

ROTISSERIE BURNER CLEANING

Due to the upper location of the Rotisserie Burner, it should not be necessary to clean it, unless food debris or juices have sprayed onto the tiles. Should this happen, after removing the food item and spit, turn the burner back on again for an additional 5 minutes to allow the burner to vaporize any residue. Do not attempt to clean the tile ports with a toothpick or other item which may break off inside the port. If needed, you may also wait until the burner has cooled completely and brush the tile faces to remove any accumulated ash.

NOTICE: Avoid directing water on the Rotisserie Burner as this may damage the ceramic burner panels. Water damage to your Rotisserie Burner is not covered by the warranty.

SEAR BURNER CLEANING

When used correctly, it should not be necessary to clean Tereaux Infrared Sear Burners. The hot screen and tiles vaporize anything that falls on them. However, if food debris or drippings were to fall on an unused (not lit) Sear Burner, you can remove the mesh screen and brush the screen and tiles with a stiff brush. Be sure to do this only when completely cooled down. **DO NOT** use a metal scraper on the tiles, or put a lot of pressure on the tile faces as they may crack. Alternatively, you can turn on the sear burner to burn everything off.

NOTICE: Avoid directing water into the Sear Burner as this may fill up the inside of the burner housing with water, not allowing it to burn properly. Water intrusion could also damage the ceramic tiles. Water damage to your Sear Burner is not covered by the warranty.

ORIFICE CLEANING

You will need to remove the burner first. It may also be helpful to remove the control panel to get a better look at the orifice. Take note of how far the orifice is tightened onto the valve. With the burner removed, remove the orifice from the valve and shine a flashlight through the opening to ensure there is no blockage. Use a sewing needle to clear any debris. Be extremely careful not to enlarge the hole or break off the needle. Once clean, be sure to carefully thread the orifice onto the valve by hand, then use a wrench or deep socket wrench to tighten it securely to the same position as before. Replace the burner as per previous instruction.

IGNITERS

The hot-surface igniters on your Tereaux Grill do not require any maintenance and are well protected from debris falling on them. You can gently clean them with a soapy water solution and a toothbrush. Wipe down with a clean cloth.

NOTE: Rough handling of the igniter can crack the ceramic body, causing it to fail. Handle with care.

CLEANING THE BRIQUETTES AND TRAYS:

After allowing the grill to cool completely, turn the radiant tray upside-down and operate the grill on high for 30 minutes. The trays are “double sided” and can be left this way to burn off any encrusted food or grease. The trays can occasionally be scrubbed clean with mild soap and water and a plastic bristle brush. Allow them to cool completely, never handle hot trays. Replace the briquette trays, ensuring that they sit level and do not rock. Light all of the burners and check for proper flame characteristics.

LIGHT BULB REPLACEMENT

1. Disconnect the power to your grill before any service or light bulb replacement. Be sure the grill
2. and the lights are completely cool. Halogen lights get extremely hot.
3. Open hood and remove the small screw holding the lamp assembly in place. Remove the lamp assembly, being careful not to drop the glass lens.
4. If needed, use a small flat-blade screwdriver to carefully pry off the lens and set aside. Loosen the 2 screws closest to the lamp housing. These screws hold the bulb in place. The bulb should come out easily. The bulb is a 20W halogen “Bi-Pin” type, available at most hardware stores and home centers.
5. Before installation, it is very important to clean the new bulb carefully with a clean, soft cloth, or tissue paper. Grease, fingerprints, or oils in your skin can leave a residue on the glass surface of the bulb which will create a hot-spot. The bulb will eventually crack at this hot-spot.
6. While still using a cloth or tissue paper, install the new bulb in the housing and tighten the screws. Check that the other tiny screws are tight as well.
7. Re-install the lens and return the lamp assembly to the hood. Carefully install the screw to secure the assembly to the hood.

ADDITIONAL CONSIDERATIONS

Always keep the area around the grill free of obstructions and debris. Maintain at least 12” [30 cm] of space around the grill to ensure proper airflow, and keep all ventilation openings clear and free of debris. Clean appliance after each use, and check for blockages, especially at the burner orifices, after periods of prolonged non-use. To maintain the appearance of your Tereaux grill for many years, keep it covered when not in use. Backyard environments are harsh on your grills’ finish. Long exposure to sun, water, yard chemicals and the elements could diminish the appearance of the stainless steel. This is very evident in ocean-front locations.

With thorough product testing, we found the grill materials were able to withstand typical outdoor exposure over prolonged periods of time. However, the above-mentioned corrosive substances, along with neglect, can lead to a situation whereby conditions might combine to cause some damage to occur. Therefore, we suggest that you always keep your grill clean, dry and covered when not in use. This is even more important when long term storage is required. Always store the grill clean, dry and covered with your Tereaux Grill Cover. A dirty grill will attract all sorts of pests. Keep your eye out for rodents, as they are known to chew on the insulation of wiring which will cause permanent damage to the wiring and possibly electrical components. Rodent damage is not covered under warranty.

For those in desert communities, wind-driven sand is highly abrasive and constant exposure will eventually pit and scratch the surface. It is recommended to keep your grill covered to minimize this issue. This is not covered under warranty.

GAS SUPPLY

For fixed installations, your local gas authority or supplier should be consulted at the installation planning stage in order to establish the availability of an adequate supply of gas (NG or LP). If it is a new installation, have the gas authorities or supplier check the meter size and piping to assure that the unit is supplied with the necessary amount of gas supply and pressure to operate the unit(s).

Gas connections should be made by a qualified plumber, or your professional outdoor appliance installer. All fixed (non-mobile) appliances must be fitted with an accessible upstream gas shutoff valve as a means of isolating the appliance for emergency shut off and for servicing.

Make certain new piping and connections have been made in a clean manner and have been purged so that piping compound, chips, etc. will not clog regulators, valves, orifices, or burners. Use pipe joint compound/ thread sealant approved for natural and LP gases.

NEVER CONNECT THE GRILL TO AN UNREGULATED GAS SUPPLY. Before proceeding, ensure the appliance is fitted for Natural or Liquid Propane gas. Connecting to an improper gas type will result in poor performance and increased risk of damage or injury. Gas type and gas consumption (BTU per hour) for each burner type is shown on the rating label affixed to the underside of the drip tray. Installation of this cooking appliance must be made in accordance with local codes. In the absence of local codes, this unit should be installed in accordance with the National Fuel Gas Code No. Z223.1/ NFPA 54, Natural Gas and Propane Installation code CSA B149-1, or Propane Storage and Handling Code B149.2.

GAS CONNECTIONS

Liquid Propane - Piped Systems

An LP piped system is one with a large central LP tank that feeds an entire household. These systems are normally equipped with a high pressure regulator by the large LP tank, and low pressure regulators close to the home. The gas line connectors must comply with the Standard for Connectors for Outdoor Gas Appliances and Manufactured Homes, ANSI Z21.75 • CSA 6.27, and suitable for outdoor installation. The max length of the connection shall be 72" [1.82 m].

NOTE: To ensure proper heating performance of this appliance, verify that the supply (inlet) pressure is adequate (11-14 inch WC [2.74-3.48 kPa] pressure is preferred) to maintain 10 inch WC [2.49 kPa] nominal outlet (manifold) pressure.

Liquid Propane – 20 lb LP Gas Cylinder

Use only a standard 20 lb. (9.1kg) liquid propane (LP) gas cylinder - 12.25" diam. X 18.25" H (31cm X 47cm) which features an Overfill Protection Device.

Natural Gas

To ensure proper heating performance of this appliance, verify that the gas line supply pressure is adequate. Use only the gas pressure regulator supplied with this appliance. This regulator is set for a supply (inlet) pressure of 7-14 inch WC [1.74-3.48 kPa] to maintain 4 inch WC [1.00 kPa] nominal outlet (manifold) pressure. Use a minimum 1/2" ID flex hose to prevent gas starvation. Ensure that the service pipe supplying the appliance is fitted with a shut-off valve conveniently positioned and easily accessible as an emergency gas shut-off.

GAS TYPE

Your appliance has been manufactured to work with either Natural Gas or LP. Each gas type requires a unique burner orifice and regulator for proper operation. Your grill includes a conversion kit if your planned gas type changes. If a conversion is required, contact your professional outdoor appliance installer or the Tereaux dealer where you purchased your grill.

LEAK TESTING

Although all gas connections on your grill are leak tested at the factory prior to shipment, a complete gas tightness check must be performed at the installation site due to possible movement in shipment, or excessive pressure unknowingly being applied to parts of the unit. Periodically check the whole system for leaks, or immediately check if the smell of gas is detected.

Before Testing

1. Do not smoke while leak testing.
2. Never leak test with an open flame.
3. Make a soap solution of one part liquid detergent and one part water for leak testing purposes.
4. For LP units, always check with a full LP cylinder.

To Test

1. Make sure all control valves are in the "OFF" position.
2. Apply the soap solution to the gas fittings by using a spray bottle or a brush.
3. Turn the gas supply on.
4. Check all connections from the supply line, or LP cylinder up to and including the manifold pipe
5. assembly.
6. Soap bubbles will appear where a leak is present. If a leak is present, immediately turn off gas supply, tighten any leaking fittings, turn the gas supply back on, and recheck.
7. If you cannot stop a gas leak, turn off the gas supply and call the Tereaux dealer where you purchased your grill.

DO NOT USE THE GRILL UNTIL ALL CONNECTIONS HAVE BEEN CHECKED AND DO NOT LEAK.

IMPORTANT NOTE - ALWAYS CHECK FOR LEAKS AFTER EVERY LP CYLINDER CHANGE

If a leak is present, or if there is evidence of excessive abrasion or wear, or the hose is cut, it must be replaced before using the grill. The hose and LP regulator are supplied as a complete assembly and must be replaced together. Do not attempt to repair or replace the hose itself. Contact your Tereaux dealer for genuine replacement part. Check all gas supply fittings for leaks before each use. It is handy to keep a spray bottle of soapy water near the shut-off valve of the gas supply line. Spray all the fittings. Bubbles indicate leaks.

Electrical Supply

Important: This appliance must be electrically grounded in accordance with local codes, or in the absence of local codes with the National Electrical Code, ANSI/NFPA 70-1990.

The grill is designed for 120 volt AC power and must be plugged into a Ground Fault Circuit Interrupter (GFCI) protected circuit. The appliance is equipped with a flexible electrical supply cord with a three-prong grounding plug. This plug must be connected to a properly grounded three-prong GFCI receptacle.

Contact an electrician if you do not have this type of receptacle available. Do not remove the grounding prong from this plug. Do not connect the grill to the electrical supply until after gas connections have been made and leak checks have been performed.

KEEP ANY ELECTRICAL CORD AND FUEL SUPPLY HOSE AWAY FROM ANY HEATED SURFACES.

1. Do not use an outdoor cooking gas appliance for purposes other than intended.
2. Always allow the grill to cool before making changes, connections, etc.
3. Unplug from the outlet when not in use and before cleaning.
4. Do not operate any outdoor cooking gas appliance with a damaged cord or plug.
5. Do not operate if the appliance malfunctions or has been damaged in any manner. Contact the manufacturer for repair.
6. To protect against electric shock, do not immerse cord or plugs in water or other liquid.
7. Do not drape the cord over the edge of a table or allow it to contact hot surfaces.
8. Use only a Ground Fault Circuit Interrupter (GFCI) protected circuit with this outdoor cooking gas appliance.
9. Never remove the grounding prong or use with a 3-prong to 2-prong ground adapter.
10. If using an extension cord, it must be rated for the power of the equipment, have a 3-prong grounding plug, and be approved for outdoor use with a W-A marking.

CHANGING GAS TYPES

Gas conversion from LP (Liquid Propane) to NG (Natural Gas) is a common procedure and all Tereaux Grills are equipped for this right out of the box. Typically, the most common conversion will be from LP to NG, as most of our grills come ready to order with an LP setup. If you would like this to be done at our factory, please contact our customer service team at www.Tereaux.com for this option.

Orifice Change Out

Your conversion kit (as seen below) is included with your grill.



Due to the risk of damage and to prevent voiding your warranty, this procedure should be completed by a licensed plumber or gas professional.

1. Shut off and disconnect the gas source from the grill
2. Remove all your Tereaux Laser Cut cooking grates and Reversible Ceramic Briquettes from the grill
3. If needed, remove the cotter pins from the far end of each burner tube
4. Lift the far end of the burner, slide the burner towards the rear of the grill and lift upward, repeat this action to remove each burner

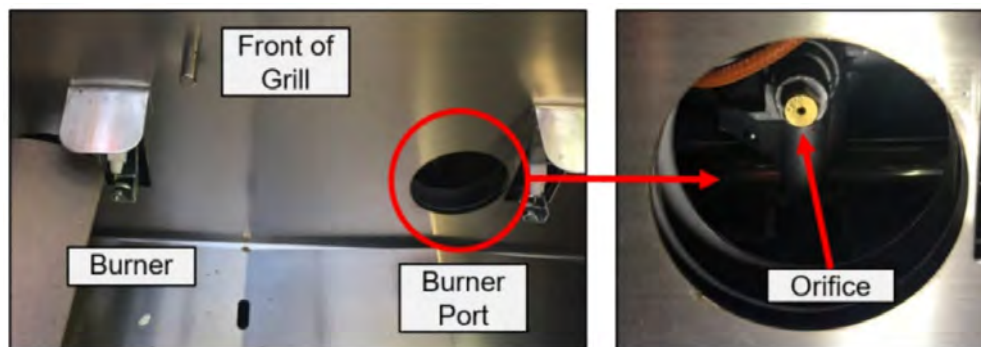

5. Use a 6mm socket to reach into the burner opening and carefully remove the brass orifice screwed into the end of the valve stem, **brass fittings are fragile, please pay careful attention to this step**
6. Replace the orifice with the change-out orifice, being very gentle with the brass fittings. Very little pressure is needed for a secure connection, use a shallow socket and no power tools, hand tight is more than enough
7. Replace the existing gas inlet with the new component for the new gas source. Remove the old inlet and replace, **hand tighten and do not over tighten**

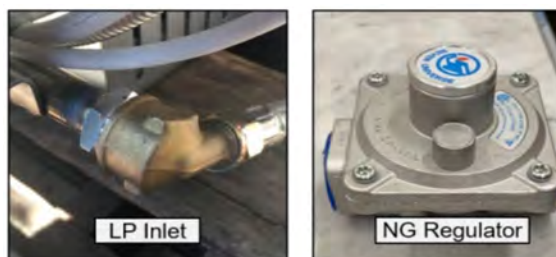

8. Connect the gas supply, heading all requirements pertaining to installation in this manual
9. Complete a leak check of all affected gas fittings per the leak test procedure in this manual
10. Adjust the air gap of each burner to match the new gas source

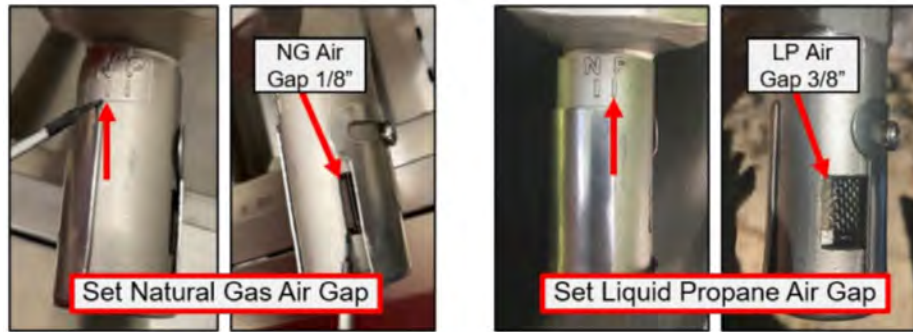

11. Replace the burners and test for proper flame height - flame should stand between .5" - 1" on low setting and 1.5" on high. Light the grill and rotate temp knob to low flame setting. Pull off the knob and adjust the setscrew shown below until flame is .5" to 1" high. Align the knob opening with the shaft and press the knob back into position
12. Replace Reversible Ceramic Briquettes and the Tereaux laser-cut cooking grates
13. Repeat this process for all main burners



REAR ROTIS BURNER CONVERSION

The rear burner must be changed for the new gas type. Complete the following steps after changing the main burner orifices, and before turning on the gas to complete the leak check.

1. Remove the access plate
2. Use a 3/8" open wrench to loosen and remove the orifice
3. Insert and tighten the new orifice until snug, then give another 1/8 turn. The NG orifice size is 1.1mm and the LP gas orifice size is 1.0mm
4. Complete orifice leak check after gas is supplied
5. Close the access panel, install and tighten all screws

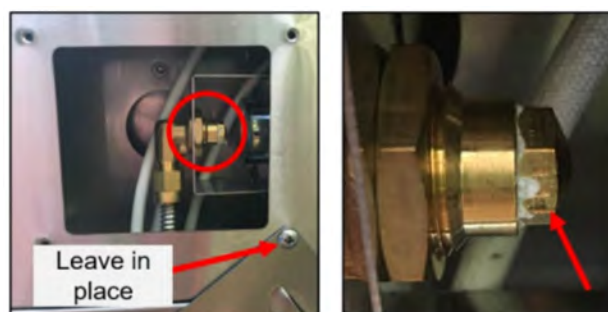

TEREAUX LIMITED WARRANTY

THIS LIMITED WARRANTY (THE “WARRANTY”) GIVES THE ORIGINAL PURCHASER (“YOU”) OF A NEW PRODUCT DIRECTLY FROM TEREAX HOLDING COMPANY (“WE” OR “US”), OR FROM OUR AUTHORIZED RETAILERS, SPECIFIC LEGAL RIGHTS, AND YOU MAY ALSO HAVE OTHER RIGHTS UNDER THE LAWS OF THE STATE WHERE YOU RESIDE. A COPY OF THIS WARRANTY IS AVAILABLE WITH OUR AUTHORIZED RETAILERS, CAN BE FOUND ONLINE AT [WWW.TEREAUX.COM/WARRANTY], AND IS INCLUDED IN THE DOCUMENTATION THAT WE PROVIDE WITH OUR PRODUCTS.

SUBJECT TO THE LIMITATIONS BELOW, WE WARRANT THAT DURING THE BELOW WARRANTY PERIODS, OUR PRODUCTS AND PARTS WILL BE FREE FROM DEFECTS IN MATERIALS AND WORKMANSHIP WHEN ASSEMBLED, INSTALLED, USED AND MAINTAINED IN ACCORDANCE WITH OUR INSTRUCTIONS INCLUDED IN THE DOCUMENTATION THAT WE PROVIDE WITH OUR PRODUCTS AND FOUND ONLINE AT WWW.TEREAUX.COM:

Luxury Grills	Warranty Period
Grates and Gas Burners	Lifetime of the Original Purchaser
Body, Exterior Panels and Hood; Briquettes and trays	5 Years
Electrical, Lighting and Power Supply, Gas Regulators and Tubing, Infrared Burner	1 Year
All other parts and Accessories	1 Year

WE ARE GIVING YOU THIS WARRANTY AND DISCLAIM ALL OTHER WARRANTIES, WHETHER EXPRESS OR IMPLIED, AND CANNOT AND SHALL NOT BE LIABLE TO YOU FOR ANY OTHER EXPRESS OR IMPLIED WARRANTIES PROVIDED BY DISTRIBUTORS, DEALERS, SALESPERSONS OR ANY OTHER REPRESENTATIVES, WHETHER WRITTEN OR ORAL. OTHER THAN THIS WARRANTY, ALL PRODUCTS AND PARTS ARE SOLD AND PROVIDED ON AN “AS-IS” BASIS.

WITHOUT LIMITING THE FOREGOING, THE DURATION AND REMEDIES OF ALL STATUTORY AND IMPLIED WARRANTIES, INCLUDING, WITHOUT LIMITATION, THE WARRANTIES OF MERCHANTABILITY AND FITNESS FOR A PARTICULAR PURPOSE, ARE LIMITED TO THE DURATION OF THE APPLICABLE WARRANTY PERIOD SET FORTH ABOVE. SOME STATES DO NOT ALLOW LIMITATIONS ON HOW LONG AN IMPLIED WARRANTY LASTS, SO THE ABOVE LIMITATION MAY NOT APPLY TO YOU.

OUR SOLE LIABILITY AND RESPONSIBILITY FOR DEFECTIVE PRODUCTS OR PARTS IS LIMITED TO REPAIR OR REPLACEMENT AS DESCRIBED IN THIS WARRANTY.

WHAT DOES THIS WARRANTY COVER AND FOR HOW LONG?

Subject to the terms of this Warranty, our products and parts are warranted to the original purchaser of a new product from us or an authorized retailer against defects in materials and workmanship for the warranty period set forth above (as applicable, the "Warranty Period"). The Warranty Period starts on the date of your original purchase from us or an authorized retailer, and is not extended if we repair or replace a product or part under the Warranty.

WHAT DOES THIS WARRANTY NOT COVER?

This Warranty will not cover you if you fail to assemble, install, use or maintain the products and parts according to our instructions, which are included with your product and available at www.tereaux.com/manuals, or if the products or parts are used in communal, commercial or food-service uses, or in any manner other than private residential use.

This Warranty also does not cover any damage due to: (a) transportation or storage, (b) improper assembly, installation, use or maintenance or any failure to follow our instructions, (c) failure to perform normal, routine or preventive maintenance, (d) modifications or unauthorized repairs or use of unauthorized parts, (e) hostile environments, including coastal environments and use in proximity pools or hot tubs, or excessive exposures to UV, wind, heat, sun, rain, hail, snow, or other elements, (f) scratches, dents, deterioration or chipping of paint, plating or other surfaces, discoloration from heat, warping of heat trays or baffles, or other normal wear and tear, or (g) other external causes such as accidents, fires, abuse, misuse, alteration, misapplication, vandalism, or other actions or events beyond our reasonable control. This Warranty also does not cover any unauthorized or third party components, parts, or accessories used by you, or damage or defects caused by such components, parts or accessories.

Whether or not a defect or damage is excluded from this Warranty is determined by us in our sole and absolute discretion.

WHO MAY USE THIS WARRANTY?

WHO MAY USE THIS WARRANTY?

We extend this Warranty only to the original purchaser of a new product directly from us or from an authorized retailer. The Warranty does not extend to any purchases of used products (including retailer floor models), or to any subsequent owner or other transferee of a product. A list of authorized retailers is available at www.tereaux.com/dealers.

Registering your new product will expedite any warranty claims you may need to make, and provides a link between you and us in case we ever need to contact you. Instructions on registering your product are included with your product and available at www.tereaux.com/registration.

This Warranty will not apply and will be void if: (a) the product is not assembled, installed, operated or maintained in accordance with our instructions included with your product and available at www.tereaux.com/manuals, (b) the product is not purchased in new condition from us or an authorized retailer, (c) the product is resold or transferred to another owner, (d) you have modified the product or have been offered replacement parts under this Warranty free of charge and elect to use third party components, parts, or accessories, (e) the product has been used in a communal, commercial or food service application; or (f) you have allowed the product to become damaged, abused or exposed to excessive elements (UV, wind, heat, sun, rain, hail, snow, or others).

WHAT ARE YOUR REMEDIES UNDER THIS WARRANTY?

With respect to any defective product or part during the Warranty Period, we will, in our sole and absolute discretion, either repair or replace, free of charge, products or parts that prove to be defective in materials or workmanship under proper and normal assembly, installation, use and maintenance, as we determine in our sole discretion. We may replace products or parts with new or refurbished products or parts in our sole discretion. We will also pay for return shipping and handling fees to return the repaired or replacement product or part to you.

Repair or replacement of a defective product or part is our entire liability and your sole and exclusive remedy.

How Do You Obtain Warranty Service?

To obtain warranty service, you, or your authorized dealer, must email our customer service department at service@tereaux.com during the Warranty Period, and no later than ninety (90) days of when a potential problem becomes known to you, to obtain a Defective Merchandise Authorization (“DMA”) number. The foregoing prompt notice of a potential problem allows us to timely repair or replace a defective product or part, without prompt notice a problem may be unable to be fixed under this Warranty or may result in other problems that will not be covered by this Warranty.

When you contact us for a DMA, you will be required to provide (a) your name and contact information, (b) the serial number of the product and location that the product is used or installed, (c) description of the problem and date first discovered, and (d) proof of purchase from us or an authorized retailer, so **please retain a copy of your receipt or invoice**. To provide a DMA number, we may require that you provide reasonable evidence of the problem, including participating in video chats, phone conversations, providing photos, and providing other relevant information. No warranty service will be provided without a DMA number. Products or parts approved for a return must be returned to us at your cost, postage prepaid, and include the DMA number for our reference. We are not responsible for returned products or parts lost in transit.

We will determine if your warranty claim is covered under this Warranty in our sole discretion and a failure to follow the procedures herein may void your warranty claim.

Our products and parts are designed to be modular to allow for at-home repairs by our customers or repairs by our authorized dealers. Our entire obligation under this Warranty is to provide you or your authorized dealer with, in our sole discretion, replacement products or parts for any products or parts deemed by us to be defective and to provide instructions on how to replace the part. Any installation or labor charges connected with the replacement or reinstallation of defective products or parts shall be paid at your expense. This Warranty imposes no obligation on us to keep all products or parts in stock, and based on the availability of products or parts, we may provide you a prorated credit towards a new product.

We frequently update the design of our products and parts, and nothing contained in this Warranty shall be construed as obligating us to incorporate such design updates into previously manufactured products or parts, nor shall such updates be construed as an admission that any previous designs were defective.

Customers outside of the United States and Canada should note that NOT all warranty policies stated herein are consistent globally. Customers should contact the local distributor in their current country for instructions regarding warranty claims specific to that country. The process described herein will not work for international warranty requests.

LIMITATION OF LIABILITY

THE REMEDIES DESCRIBED ABOVE ARE YOUR SOLE AND EXCLUSIVE REMEDIES AND OUR ENTIRE LIABILITY FOR ANY BREACH OF THIS WARRANTY.

OUR LIABILITY SHALL UNDER NO CIRCUMSTANCES EXCEED THE ACTUAL AMOUNT PAID BY YOU FOR THE DEFECTIVE PRODUCT, NOR SHALL WE UNDER ANY CIRCUMSTANCES BE LIABLE FOR ANY CONSEQUENTIAL, INCIDENTAL, SPECIAL OR PUNITIVE DAMAGES OR LOSSES, WHETHER DIRECT OR INDIRECT, OR ENHANCED DAMAGES, LOST PROFITS OR REVENUES, OR DIMINUTION IN VALUE ARISING OUT OF OR RELATING TO YOUR USE OF OUR PRODUCTS, WHETHER A CLAIM IS FOR BREACH OF WARRANTY, PRODUCT DEFECT, NEGLIGENCE, OR OTHERWISE.

SOME STATES DO NOT ALLOW THE EXCLUSION OR LIMITATION OF LIABILITIES OR DAMAGES, SO THE ABOVE LIMITATIONS OR EXCLUSIONS MAY NOT APPLY TO YOU.

What Can You Do In Case of a Dispute with Us?

The following informal dispute resolution procedure is available to you if you believe that we have not performed our obligations under this Warranty. If you are dissatisfied with the remedy provided to you under this Warranty or have any other claim or dispute against us related to our products, you agree to submit such disagreement or dispute initially to mediation. If we are unable to resolve the disagreement or dispute with you by mediation, you agree that the matter will be submitted to binding arbitration pursuant to the Commercial Arbitration Rules of the American Arbitration Association (including the Optional Appellate Arbitration Rules) or another similar mutually agreeable association or service. The mediation and arbitration shall be carried out in Reno, Nevada, and judgment upon the award rendered pursuant to such proceeding may be entered in any court having jurisdiction thereof. The dispute resolution process described herein will apply to all claims and disputes of any nature relating to our products including, without limitation, claims for breach of contract or breach of warranty, claims for violation of state or federal laws or regulations, claims based in tort, negligence or product liability, claims based in fraud or fraud in the inducement, marketing or advertising claims and claims related to the enforceability or effect of any term of this Warranty or this dispute resolution process, including, but not limited to, the waivers of class action and jury trials.

You must use the above informal procedure, which limits your ability to pursue legal remedies in the courts.

WAIVER OF CLASS AND CONSOLIDATED ACTION. ALL CLAIMS AND DISPUTES OF ANY NATURE RELATED TO OUR PRODUCTS MUST BE ARBITRATED OR LITIGATED ON AN INDIVIDUAL BASIS AND NOT ON A CLASS BASIS, AND CLAIMS OF MORE THAN ONE CUSTOMER CANNOT BE ARBITRATED OR LITIGATED JOINTLY OR CONSOLIDATED WITH THOSE OF ANY OTHER CUSTOMER OR USER. YOU AGREE THAT YOU MAY ASSERT CLAIMS OR DISPUTES AGAINST US ONLY ON AN INDIVIDUAL BASIS AND NOT AS A PLAINTIFF OR CLASS MEMBER IN ANY CLASS OR REPRESENTATIVE ACTION OR PROCEEDING.

WAIVER OF JURY TRIAL. YOU HEREBY WAIVE ALL RIGHTS TO HAVE A TRIAL IN FRONT OF A JURY, AND INSTEAD ELECT THAT ALL CLAIMS AND DISPUTES OF ANY NATURE RELATED TO OUR PRODUCTS SHALL BE RESOLVED BY ARBITRATION AS CONTEMPLATED BY THIS WARRANTY. IN THE EVENT ANY LITIGATION SHOULD ARISE BETWEEN YOU AND US IN ANY STATE OR FEDERAL COURT IN A SUIT TO VACATE OR ENFORCE AN ARBITRATION AWARD OR OTHERWISE, YOU WAIVE ALL RIGHTS TO A JURY TRIAL, INSTEAD ELECTING THAT THE DISPUTE BE RESOLVED BY A JUDGE. SOME STATES DO NOT ALLOW THE FOREGOING WAIVERS, SO THEY MAY NOT APPLY TO YOU.

Governing Law

This Warranty shall be governed by, construed and enforced according to the laws of the State of Nevada, notwithstanding any conflicts of law or choice of law principle to the contrary.

Revisions to Warranty

We may amend the terms of this Warranty or change its availability at our sole discretion, but any amendments or changes will not be retroactive.

Jurisdiction Specific Provisions

For Residents of Quebec: Certain provisions of this Warranty will not apply to residents of Quebec to whom the Quebec Consumer Protection Act applies.

For Residents of California: EXCEPT AS PROVIDED IN THIS WARRANTY, OUR PRODUCTS ARE SOLD ON AN "AS-IS" BASIS AND YOU HAVE ALL RISK AS TO QUALITY AND PERFORMANCE AND ASSUME THE COST OF SERVICE AND REPAIR. Our authorized retailers located in California are authorized to service and repair our products and parts, and to replace parts under this Warranty. These retailers also have access to service information and replacement parts under this Warranty. A list of California authorized retailers is available at [www.tereaux.com/dealers]. Certain other provisions of this Warranty may not apply to residents of California to whom the California Song-Beverly Consumer Warranty Act applies.

If you have any questions on this Warranty, or its terms or application, please contact us at service@tereaux.com.

For more details on registration, installation, features, how to videos and questions, please scan this QR code for more product specific information or visit www.Tereaux.com and go to the product page.

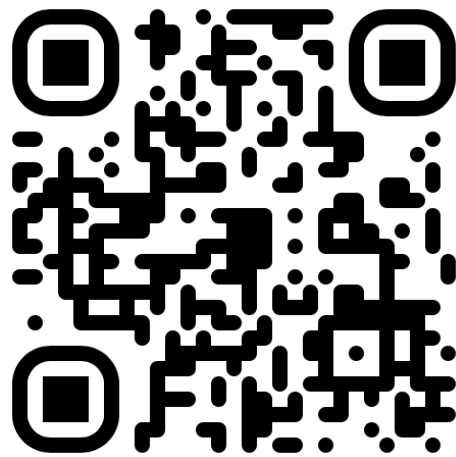

WWW.TEREAUX.COM



A GRILL WITH NO COMPROMISES

DESIGNED FOR A LIFE OUTDOORS

TERRA/EARTH
EAUX/WATER





Earth & Water

WWW.TEREAUX.COM