

FERMAX

Cod. 97450 V07_10

- Ⓔ TARJETERO PANORÁMICO (V-W)
- Ⓔ PANORAMIC CARD HOLDER (V-W)
- Ⓔ PORTE-CARTES PANORAMIQUE (V-W)
- Ⓔ BESCHRIFTUNGSFELDMODUL GRAU (V-W)



Dimensiones: Ancho (H) x Alto (V)
 Dimensions: Width (H) x Height (V)
 Dimensions: Largeur (H) x Hauteur (V)
 Massangaben: Breite (H) x Höhe (V)

V = 105,2 (H) x 47,5 (V) mm.
 W = 105,2 (H) x 95 (V) mm.

- Ⓔ Desmontaje
- Ⓔ Disassembly
- Ⓔ Démontage
- Ⓔ Ausbau

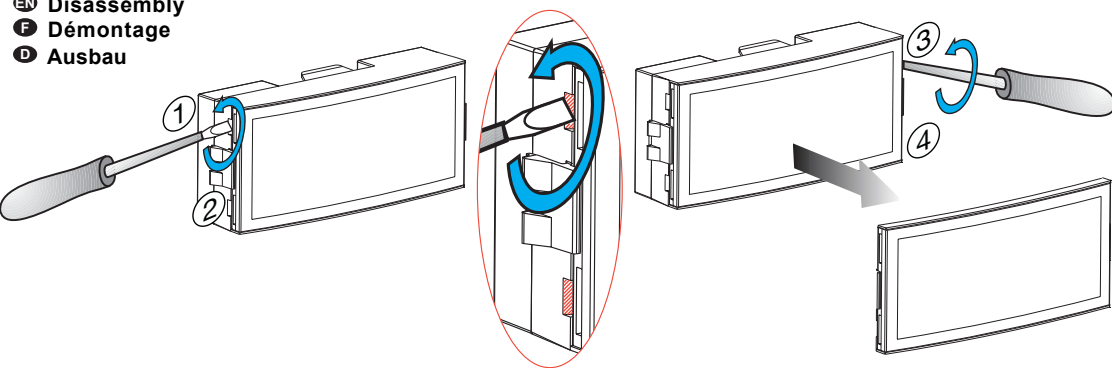

- Ⓔ Montaje
- Ⓔ Assembly
- Ⓔ Montage
- Ⓔ Einbau

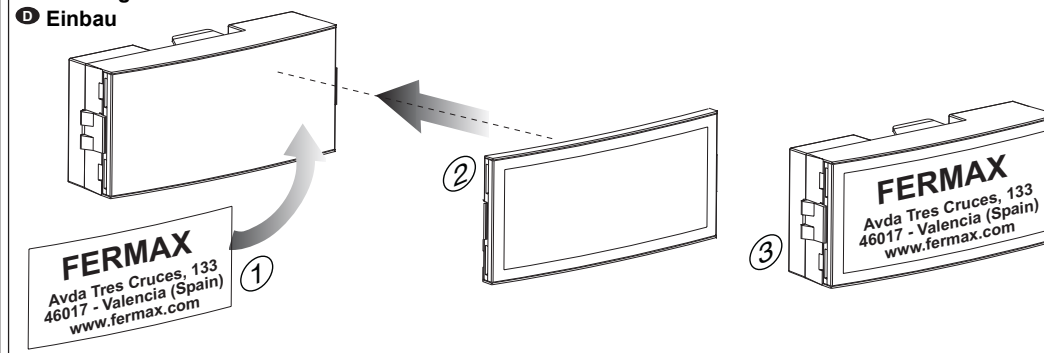

FREUND ELEKTRONIK A/S