

MPS-Series

Modular Paging and Emergency Microphones

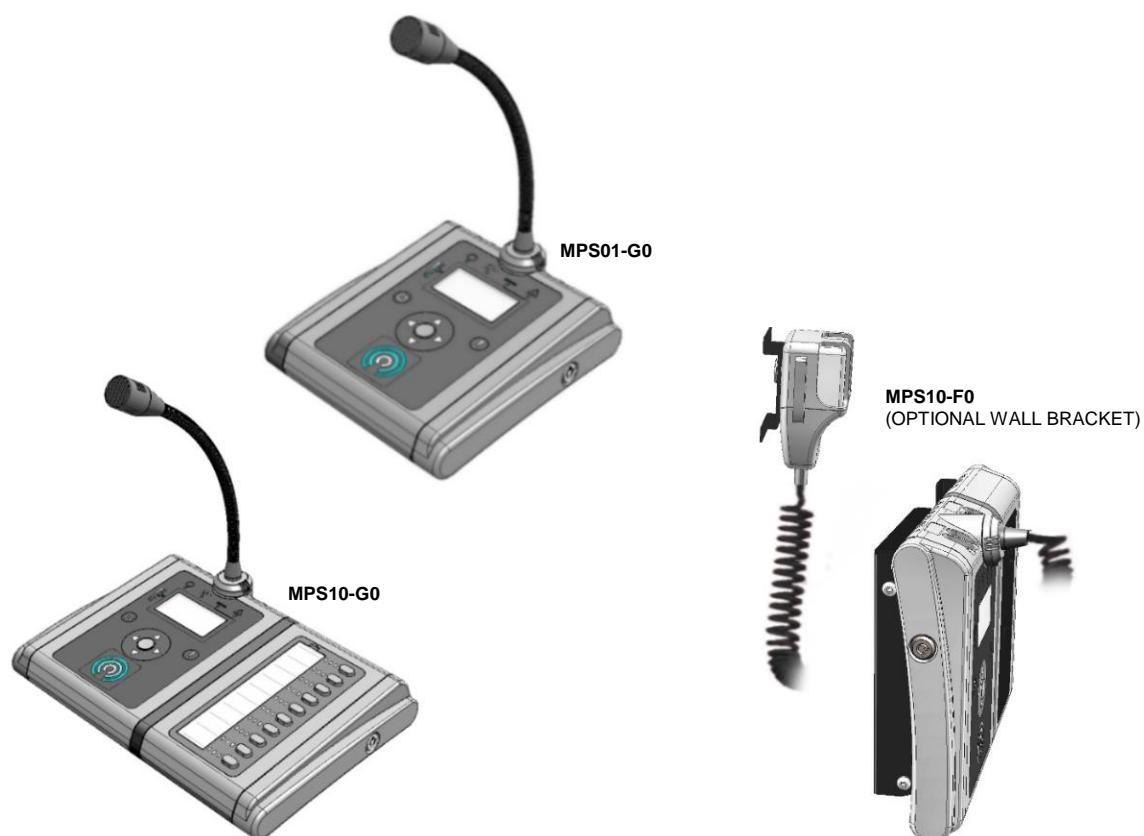

Installation Guide



This product is designed and manufactured to comply with the following EC Directives for electrical and electronic equipment:

- 1) Restriction of Hazardous Substances (RoHS) Directive: 2011/65/EU
- 2) Electromagnetic Compatibility (EMC) Directive: 2014/30/EU
- 3) Low Voltage (LVD) Directive: 2014/35/EU

A “Declaration of Conformity” statement to the above Directives, listing the applicable harmonised standards to which the equipment conforms, is available on request.

The MPS is assessed for safety as suitable for pollution degree 2 environments.

Failure to use the equipment in the manner described in the product literature will invalidate the warranty.



This product must be disposed of in accordance with the WEEE directive.

Contents

1	Technical Specification	3
2	Controls and Indicators	5
3	Installation.....	7
4	Connections.....	18
5	Mechanical Dimensions	22
6	Safety and Precautions.....	23

Additional User Documentation:

Additional reference information is available from the ASL's website at www.asl-control.co.uk

Copyright © 2019 Application Solutions (Safety and Security) Limited

Application Solutions (Safety and Security) Limited
Unit 17 Cliffe Industrial Estate
Lewes - East Sussex
BN8 6JL - UK

Tel: +44(0)1273 405411 Fax: +44(0)1273 405415

www.asl-control.co.uk

All rights reserved.

Information contained in this document is believed to be accurate. However, no representation or warranty is given and Application Solutions (Safety and Security) Limited assumes no liability with respect to the accuracy of such information.

1 Technical Specification

Supply Voltage Range.....	15 – 40 V DC or PoE (42 – 57 V DC) ¹
Current Consumption (minimum at 24 V DC supply - all LEDs off, LCD display backlight off and sounder off)	
MPS01.....	90 mA
MPS10.....	95 mA
MPS20.....	100 mA
Current Consumption (maximum at 24 V DC supply - all LEDs on, LCD display backlight on and sounder on) ²	
MPS01.....	165 mA
MPS10.....	220 mA
MPS20.....	275 mA
Emergency Microphone	EN 54-16, ISO 7240-16 and BS 5839-8 compliant
Microphone	gooseneck or fist with integral PTT button
LED Indicators.....	Speak Now / Power / Voice Alarm / System fault / Fault / Speech volume bargraph
LCD Display	128 x 64 pixels / 58 mm x 29 mm view area / English text
Control Buttons	capacitive touch buttons
Push-To-Talk (PTT)	Touch-To-Talk™ (TTT)
Navigation Wheel	LCD display navigation and selection / fault clearing ³
Menu Controls	LCD display mode selection / fault acknowledgement ³
Function Buttons (zone selection or other function) ⁴	
MPS01.....	via navigation wheel and LCD display
MPS10.....	via navigation wheel and LCD display / 10 buttons
MPS20.....	via navigation wheel and LCD display / 20 buttons
Keyswitch.....	emergency mode selection and EN54-16 access level control
Speaker.....	built-in speaker for listen-in and fault indication
ASL PA/VA System Connections ⁵	2 x microphone interfaces (RJ45) and 1 x auxiliary microphone interface (RJ45)
Audio Output.....	analogue audio / balanced / 0 dBu nominal / 220 Ω
Surveillance Tone.....	23 Hz / -10dBu (nominal)
Microphone Control Data.....	EIA RS485 / 19200 baud ⁶
Hardware Bypass Interface ⁷	Push-To-Talk switch and Speak Now LED
Listen-in Input.....	single analogue listen-in input / balanced / 0 dBu nominal / 10 kΩ
IP Connection ⁸	1 x 100BASE-T Ethernet (RJ45)
Audio Output.....	VoIP audio
Control Data	microphone, listen-in and IP network control data ⁹
Listen-in.....	digital audio
Others.....	firmware upgrade and microphone configuration
USB Interface.....	1 x USB 2.0 (USB type B)
Audio Input.....	1 x 3.5 mm socket (balanced or unbalanced stereo audio input, music input)
Audio Output	1 x 3.5 mm socket (unbalanced stereo audio output, headphone, external speakers)
Contact Input.....	1 x 3.5 mm socket (contact closure to ground, internal 10 kΩ pull up to +3.3 V)
Contact Output.....	1 x 3.5 mm socket (open-collector)

¹ PoE (Power over Ethernet) does not provide EN 54-16 compliance.

² Microphones with more zone selection buttons: additional 55 mA per MPX10 10-button Expansion Module.
Maximum current consumption with fault sounder level set to 50%. Additional 40 mA if fault sounder is set to maximum level.

³ Fault acceptance and clearance only available in emergency mode.

⁴ Special variants are available to order, with more zone selection buttons; see ordering code on page 4.

⁵ ASL PA/VA systems (refer to ASL for connectivity and software compatibility details): VAR4/12/20, VAR8, VAR8-ACU, VIPEDIA-12, iPAM400, iPA400, VIPET, other VIPA devices.

⁶ ASL protocols supported on the serial connection: ASL Serial, Paging (DMS) and Console (ACU). The protocol is defined by the host, and the MPS will automatically discover the protocol upon connection.

⁷ Hardware bypass is only provided on inputs 1 and 2 of ASL Voice Alarm Routers.

⁸ IP interface does not provide EN 54-16, ISO 7240-16 or BS 5839-8 compliance at the time of publication of this Installation Guide. Note that Ethernet connectivity is enabled for the IP variant with an additional IP licence.

⁹ ASL protocols supported over IP: ASL Serial, TRL (Transactionless) and Paging (DMS). The protocol is defined by the host (if any), and the MPS will automatically discover the protocol upon connection.

Facilities¹

Message Storage 10 messages of 40 seconds each (minimum) on a micro-SD card
 Custom Language stored on a micro-SD card
 Store and Forward announcement of up to 60 seconds

Format / Colour sloping desk console with optional wall-mounting bracket(s)² / grey and black

Dimensions (H x W x D) / Weight

MPS01 58 mm x 175 mm x 200 mm (excluding gooseneck) / 1 kg
 MPS10 58 mm x 285 mm x 200 mm (excluding gooseneck) / 1.2 kg
 MPS20 58 mm x 395 mm x 200 mm (excluding gooseneck) / 1.4 kg
 Gooseneck Microphone Height 260 mm (maximum)

Temperature (storage and operating) -20 °C to +55 °C (storage) / 0 °C to +55 °C (operation)

Humidity Range 0% to 93% non-condensing

Ordering Code – Microphone

	MPS	01	-	G0	-	AN
Microphone series:						
MPS Modular Microphone Station						
Number of microphone buttons:						
01 None						
10 10 buttons (right-hand side)						
20 20 buttons (right-hand side)						
30 30 buttons (custom layout)						
40 40 buttons (custom layout)						
50 50 buttons (custom layout)						
Microphone type:						
00 None						
G0 Gooseneck						
F0 Fist						
Connectivity:						
AN Analogue interface						
IP IP and analogue interfaces						

Ordering Code – Optional Items

Optional Item	ASL Part Number
MPS01 Wall Mount Kit	A0664120
MPS10+ Wall-Mount Kit	A0664121 (for MPS10 and MPS20 only)

¹ Refer to ASL for availability.

² Wall-mount option only available for MPS01, MPS10 and MPS20.

2 Controls and Indicators

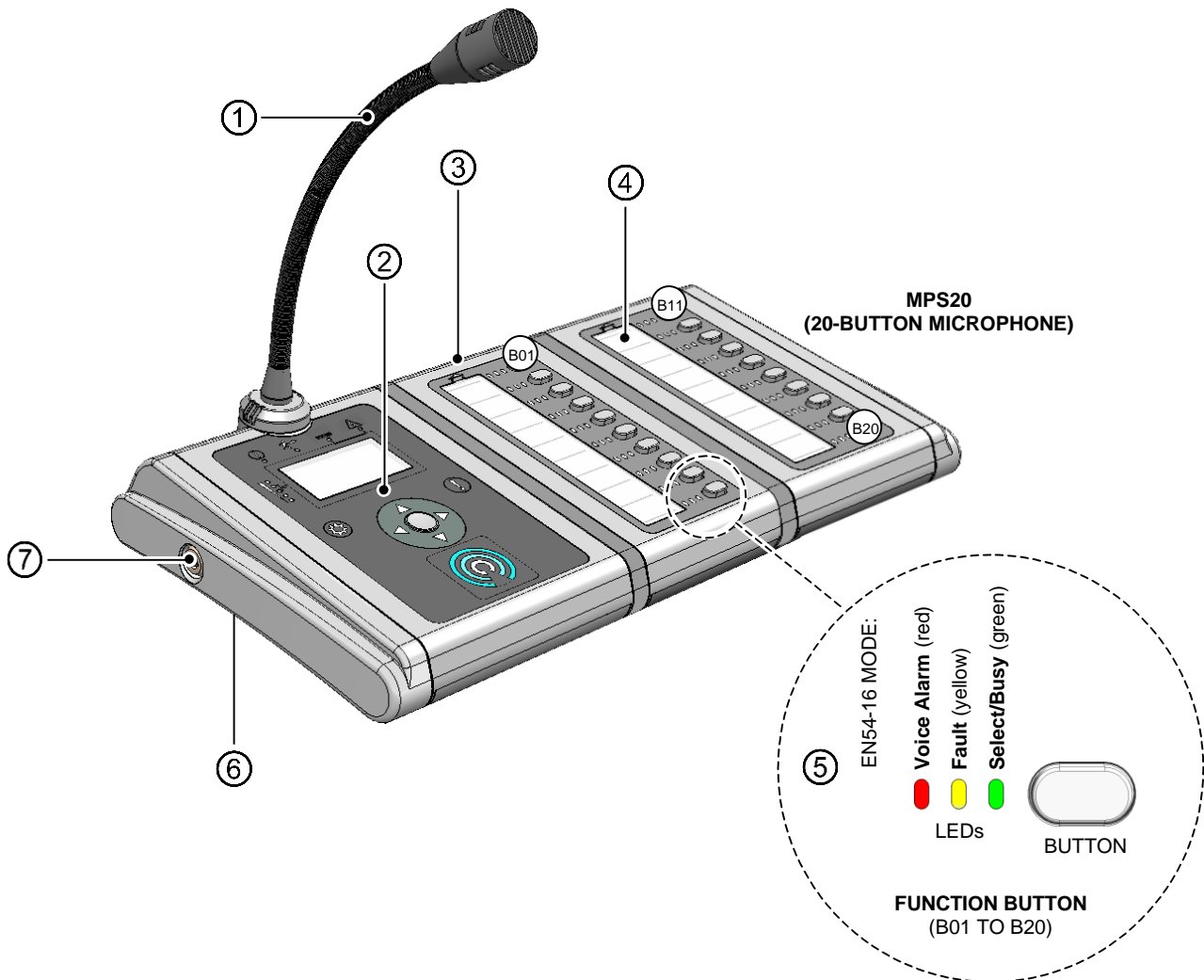

Item	Description
①	Gooseneck microphone
②	Main user interface (see details below)
③	MPX10 10-button Expansion Module ³ : <ul style="list-style-type: none"> • MPS01: none fitted • MPS10: one fitted • MPS20: two fitted
④	Function button identification label (under plastic cover)

Item	Description
⑤	Function button ¹ and indicators. EN 54-16 indication mode ² : <ul style="list-style-type: none"> • Red LED = Voice Alarm • Yellow LED = Fault • Green LED = Select/Busy
⑥	Built-in loudspeaker (under the unit)
⑦	Emergency mode keyswitch

¹ The available functions depend on the PA/VA system that hosts the microphone.

² Refer to the application specific documentation for other indication modes.

³ Special variants are available to order, with more MPX10 button expansion modules and/or button module to the left of the gooseneck microphone and/or to the right.

Main User Interface

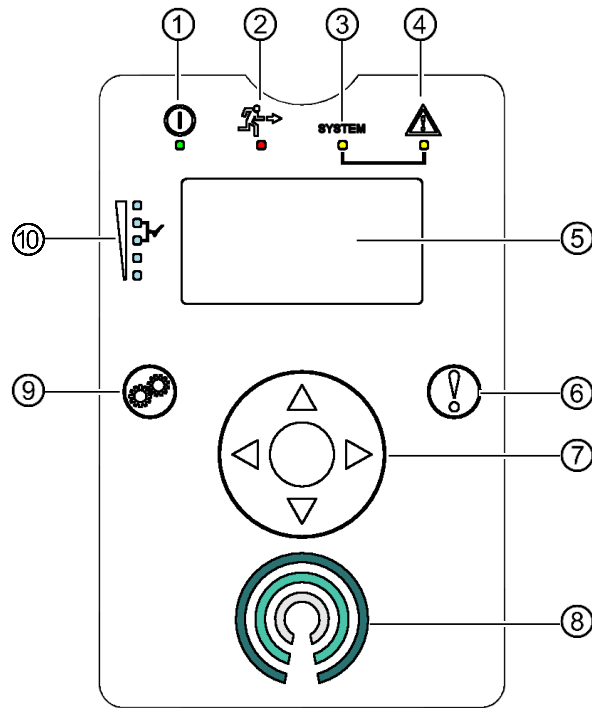

Item	Indicator/Control	Description	
①	Power On LED (green)	Lit if the unit is receiving DC power.	EN54-16 mandatory indication (may be unused in other applications)
②	Voice Alarm LED (red)	Lit to indicate that a Voice Alarm condition is present in the PA/VA system.	
③	SYSTEM System Fault LED (yellow)	Lit to indicate that a system fault has been detected in the PA/VA system. A system fault will always cause the "fault" LED to be lit as well. It is triggered by a failure of any processor or memory, critical to the Voice Alarm system.	
④	Fault LED (yellow)	Lit to indicate that a fault has been detected in the PA/VA system. Flashes if a fault has not yet been accepted.	
⑤	LCD display	Backlit transreflective graphic display for information, configuration and operation.	
⑥	Menu selection button	Toggles between fault and operation menus. In Emergency Mode, accepts all current faults reported at the connected PA/VA System, steadies the flashing "fault" LED indication, and turns off the audible alarm until a new fault condition occurs.	
⑦	Navigation wheel	Navigation controls: up (▲), right (▶), down (▼) and left (◀) Selection control: <ul style="list-style-type: none"> Touches in the centre are interpreted as "select" Fast menu scrolling: clockwise or anti-clockwise strokes In Emergency Mode with Fault menu selected, touching in the centre clears all faults reported at the connected PA/VA System and sets all connected equipment to the "no faults" state, which also cancels any amplifier changeovers in effect. Any persistent faults will be reported again on the next monitoring cycle. 	
⑧	PTT button and indicator	Push to Talk button with Speak Now indicator for microphone paging operation.	
⑨	Menu selection button	Toggles between configuration and operation menus.	
⑩	Bargraph LED (blue)	Speech level indication with target level marking (✓).	

3 Installation

3.1 Equipment and Tools

- The MPS01, MPS10 or MPS20 unit
- A pair of wire cutters/strippers
- An RJ45 (8P8C) crimping/cable termination tool (only for installation of the wall plate connector)
- A Pozidriv screwdriver (No 2)
- For wall or desk/console mounting:
 - ASL Wall-Mount Kit as required
 - A T20 Torx driver
 - A 3 mm A/F hex driver
 - Suitable fixings and tools for wall or desk/console mounting (fixing hole diameter 5.5 mm)
- Cabling from microphone position to the central equipment (normally part of the building installation)
- For MPS10 to MPS50: completed slip-in button identification labels (from supplied label or from the Microsoft Word® template available from ASL)

3.2 External Cabling

3.2.1 Non-Emergency Applications

Connection	Signals	Cable Description	Termination	Suggested Type
From microphone to wall socket	Audio	1 twisted pair, overall screened	RJ45 (Mic Port)	Suitable CAT5 STP or FTP patch lead
	Microphone data	1 twisted pair, overall screened		
	Power supply	2 twisted pairs, overall screened		
	Listen-in (optional)	1 twisted pair, overall screened	RJ45 (Mic Aux Port)	Suitable CAT5 STP or FTP patch lead
From wall socket to central rack (normally part of the building installation)	Audio	1 twisted pair, overall screened	<ul style="list-style-type: none"> • Wall socket: RJ45 (Mic Port) • Central rack: per rack design 	Standard CAT5 STP or FTP cable
	Microphone data	1 twisted pair, overall screened		
	Power supply	2 twisted pairs, overall screened		
	Listen-in (optional)	1 twisted pair, overall screened	<ul style="list-style-type: none"> • Wall socket: RJ45 (Mic Aux Port) • Central rack: per rack design 	Standard overall screened cable or standard CAT5 STP or FTP cable
Other connections	Ethernet and PoE	Screened LAN cable	RJ45 (Ethernet Port)	Suitable CAT5 STP cable
	USB	USB cable	USB type B (USB Port)	As required to connect to the external device being used
	Audio input	1 x 2-core, screened	3.5 mm plug (Mic)	Suitably rated 2-core cable
	Audio output/headset microphone	1 x 2 or 3-core, screened	3.5 mm plug (Mic)	Suitably rated 2 or 3-core cable
	Contact input	1 x 2-core	3.5 mm plug (Mic)	Suitably rated 2-core cable
	Contact output	1 x 2 or 3-core	3.5 mm plug (Mic)	Suitably rated 2 or 3-core cable



Refer to BS7671 (Requirements for Electrical Installations) or other appropriate local standards for guidelines on maximum potential cable lengths given the actual installation parameters.



- 1) Excessively large RJ45 cables will not fit the strain relief guides. RJ45 plugs with excessively bulky rubber boot will not fit the connectors on the MPS properly; see cable and rubber boot dimensions in Figure 1 (page 8). Suitable CAT5 patch leads are supplied with the microphone (ASL P/N 208440).
- 2) For EMC compliance:
 - Screened cables must be used where specified.
 - All screen tails must be less than 3 cm.

3.2.2 Emergency Applications



Connection	Signals	Cable Description	Termination	Suggested Type		
From microphone to wall socket	Audio	1 twisted pair, overall screened	RJ45 (Mic Port)	Suitable CAT5 STP or FTP patch lead		
	Microphone data	1 twisted pair, overall screened				
	Power supply	2 twisted pairs, overall screened				
	PTT switch	Speak Now LED	1 twisted pair, overall screened	RJ45 (Mic Aux Port)	Suitable CAT5 STP or FTP patch lead	
						Listen-in (optional)
From wall socket to central rack (normally part of the building installation)	Audio	1 x 2-core, twisted, screened, 1.0 mm	<ul style="list-style-type: none"> Wall socket: RJ45 (Mic Port) Central rack: per rack design 	Low Smoke and Fume (LSF) Fire rated cable (e.g. Pirelli FP200) Fire resistant equivalents of standard CAT5 cable can be used		
	Microphone data	1 x 2-core, twisted, screened, 1.0 mm				
	Power supply	1 x 2-core, twisted, screened, 1.0 mm				
	PTT switch	Speak Now LED	1 x 2-core, screened, 1.0 mm	<ul style="list-style-type: none"> Wall socket: RJ45 (Mic Aux Port) Central rack: per rack design 	Low Smoke and Fume (LSF) Fire rated cable (e.g. Pirelli FP200) Fire resistant equivalents of standard CAT5 cable can be used	
						Listen-in (optional)
Other connections	Ethernet and PoE	Screened LAN cable	RJ45 (Ethernet Port)	Suitable CAT5 STP cable		
	USB	USB cable	USB type B (USB Port)	As required to connect to the external device being used		
	Audio input/music	1 x 2-core, screened	3.5 mm plug (Mic)	Suitably rated 2-core cable		
	Audio output/headset microphone	1 x 2 or 3-core, screened	3.5 mm plug (Mic)	Suitably rated 2 or 3-core cable		
	Contact input	1 x 2-core	3.5 mm plug (Mic)	Suitably rated 2-core cable		
	Contact output	1 x 2 or 3-core	3.5 mm plug (Mic)	Suitably rated 2 or 3-core cable		
	a) PTT (Push-To-Talk) and Speak Now LED connections are only required if the ASL hardware bypass emergency microphone functionality is being used (with inputs 1 or 2 of ASL Voice Alarm Routers). b) Refer to BS7671 (Requirements for Electrical Installations) or other appropriate local standards for guidelines on maximum potential cable lengths given the actual installation parameters.					
		1) Excessively large RJ45 cables will not fit the strain relief guides. RJ45 plugs with excessively bulky rubber boot will not fit the connectors on the MPS properly; see cable and rubber boot dimensions in Figure 1 (page 8). Suitable CAT5 patch leads are supplied with the microphone (ASL P/N 208440). 2) Emergency Microphones that are used as location for display of mandatory EN 54-16 indications and controls should have dual power supply: one power supply connected to ROUTER 1 port, and the other power supply to ROUTER 2 port. 3) Headset microphone cannot be used in emergency mode. 4) For EMC compliance: <ul style="list-style-type: none"> Screened cables must be used where specified. All screen tails must be less than 3 cm. 				

Figure 1 RJ45 cable and rubber boot maximum dimension



3.3 Recommended Installation Procedure

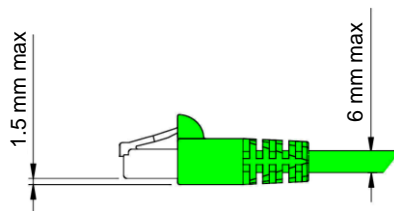

Please read and observe the safety information guidelines available on the product and in Section “6 Safety and Precautions” (page 23) prior to installation. Failure to follow these guidelines may cause personal injury and/or damage to the equipment.

3.3.1 Desktop Installation Procedure

1. Connect the installation wiring to the wall socket connector(s) to suit the installation requirements of the specific location.

Refer to Section “4 Connections” (page 18) for connection details.

2. Insert the completed button identification label into the label slot as required; see Figure 2 (page 9).

Figure 2 Fitting the zone identification label

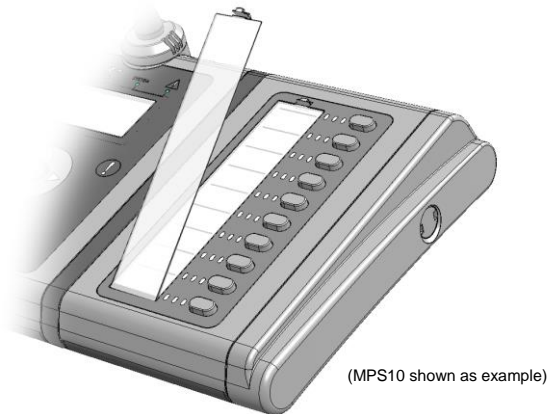

- 1) Remove the label protection cover by pressing in on the plastic clip and lifting the cover off.
- 2) Fit the zone identification label into the slot.
- 3) Fit the label protection cover back in place.

3. If not fitted, fit the gooseneck or fist microphone to the microphone case; see Figure 3 (page 9).

Figure 3 Fitting the microphone to the microphone base

- 1) Connect the flying lead(s) from the gooseneck (or fist) microphone to the appropriate connector(s) on the lead(s) coming out of the microphone base.

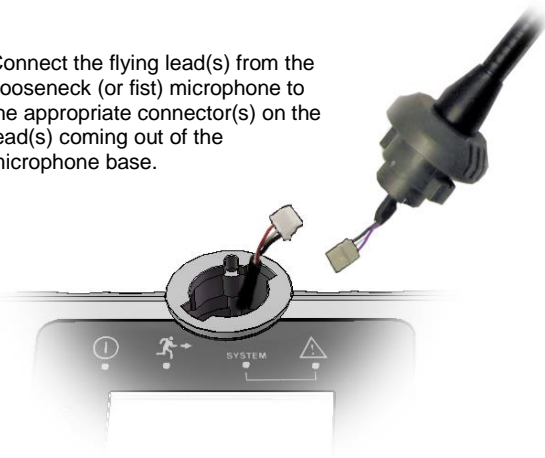

(Gooseneck microphone shown as example)

- 2) Carefully insert the microphone holder into the hole on the microphone case.
- 3) Twist the microphone holder clockwise until the screw hole is aligned with the fixing hole on the microphone case.
- 4) Secure the microphone using the M3 hex screw (15 mm) and Allen key (2.5 mm) provided.

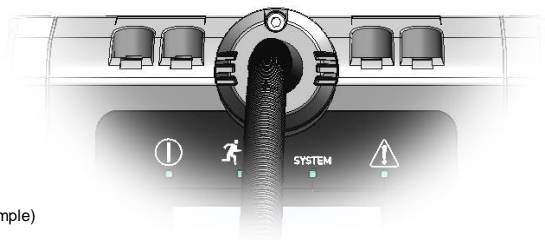

4. Remove the bottom cover by undoing 2 x M4 screws (Pan Head Pozidriv, 15 mm length), and configure the microphone as required; see Figure 16 (page 17).

5. Ensure that the power supply from the central equipment rack or PoE is turned off.
6. Connect the field cabling from the wall socket to the microphone as required; see Figure 17 (page 18).
7. If used, connect the external audio/music input and/or the speaker/headset audio output, and the contact input and/or output; see Figure 17 (page 18).
8. Route the cables through the cable strain relief guides at the bottom of the microphone and re-fit the cover; see Figure 17 (page 18).

Note that a dedicated cable strain relief guide is provided for the audio input/output cables. The contact input/output cables can use the standard cable strain relief guides if required.

	<p>If the MPS microphone is to be used as an Emergency Microphone, ensure that the unit's IP30 rating is preserved by:</p> <ul style="list-style-type: none"> • fitting any unused 3.5 mm sockets with an anti-dust cap plug (supplied) and • fitting any unused large cable strain relief guides with a blanking sponge cord (supplied).
---	---

9. If a gooseneck microphone is used, fit the foam windshield to the microphone capsule housing; see Figure 4 (page 10).

Figure 4 Fitting the foam windshield



10. If the MPS microphone is to be used as an Emergency Microphone, place the supplied pictogram label adjacent to the microphone; see example in Figure 5 (page 10).

Figure 5 Example of pictogram label

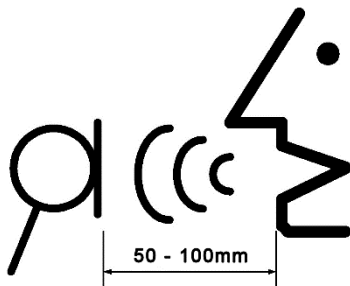

	<p>BS5839-8 requires the pictogram label to be placed so that it is clearly visible to any person operating the microphone.</p>
---	---

11. The installation is now complete and ready for system commissioning.

3.3.2 Wall and Desk/Console Mounting Installation Procedure



To prevent injury, this microphone must be securely attached to the wall/desk in accordance with these installation instructions.

1. Connect the installation wiring to the wall socket connector(s) to suit the installation requirements of the specific location. Refer to Section “4 Connections” (page 18) for connection details.
2. Insert the completed button identification label into the label slot as required; see Figure 6 (page 11).

Figure 6 Fitting the zone identification label

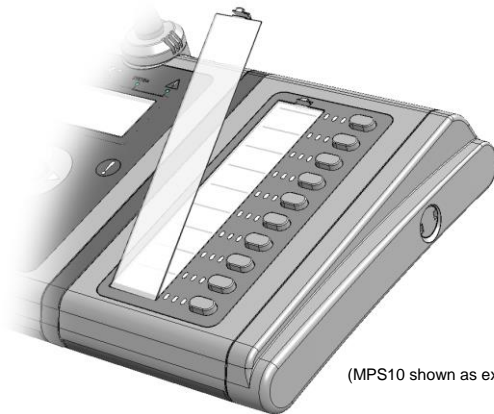

(MPS10 shown as example)

- 1) Remove the label protection cover by pressing in on the plastic clip and lifting the cover off.
- 2) Fit the zone identification label into the slot.
- 3) Fit the label protection cover back in place.

3. Remove the four Torx screws that retain the case bottom half using a T20 driver (do not remove the end cheeks' fixing screws); see Figure 7 (page 11).

Figure 7 Removing the case bottom half

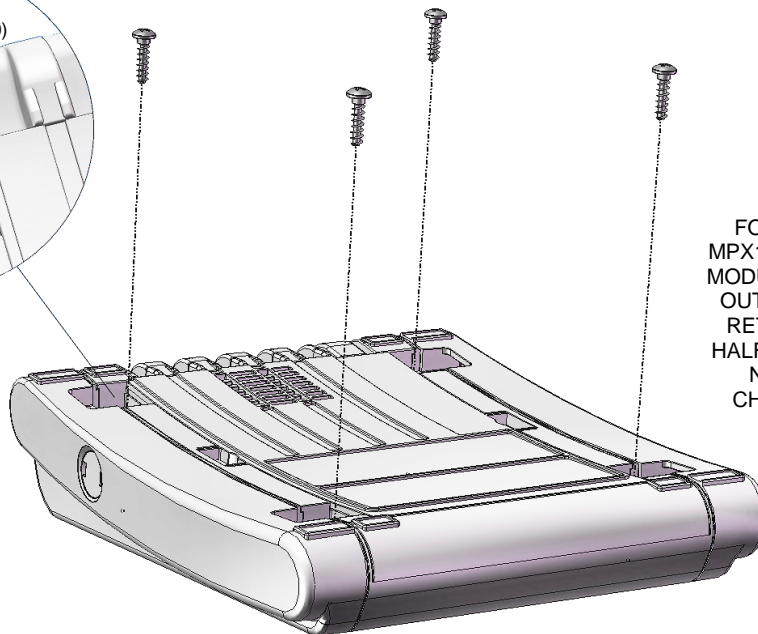

FOR MICROPHONES WITH MPX10 10-BUTTON EXPANSION MODULE(S), REMOVE THE TWO OUTER TORX SCREWS THAT RETAIN THE CASE BOTTOM HALF OF THE LAST MPX10 (DO NOT REMOVE THE END CHEEKS' FIXING SCREWS)

- Fit the long and short legs as shown in Figure 8 (page 12) using the previously removed Torx screws.

Figure 8 Fitting the long and short legs to the microphone case

MPX10 10-BUTTON EXPANSION MODULE:
LONG AND SHORT LEGS ON LEFT-HAND
SIDE ONLY

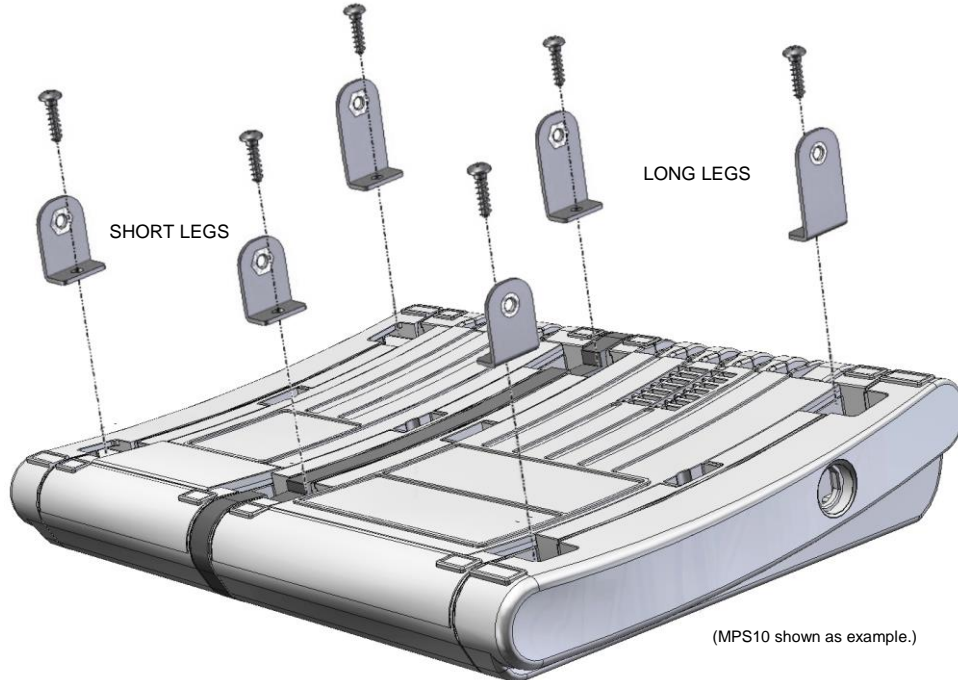

- If not fitted, fit the gooseneck or fist microphone to the microphone case; see Figure 9 (page 12).

Figure 9 Fitting the microphone to the microphone base

- Connect the flying lead(s) from the gooseneck (or fist) microphone to the appropriate connector(s) on the lead(s) coming out of the microphone base.

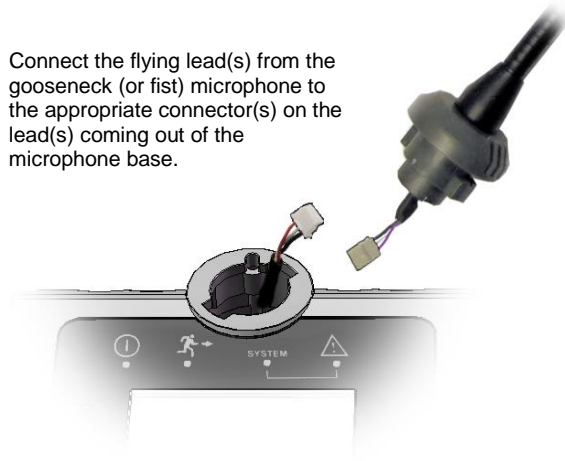

(Gooseneck microphone shown as example)

- Carefully insert the microphone holder into the hole on the microphone case.
- Twist the microphone holder clockwise until the screw hole is aligned with the fixing hole on the microphone case.
- Secure the microphone using the M3 hex screw (15 mm) and Allen key (2.5 mm) provided.

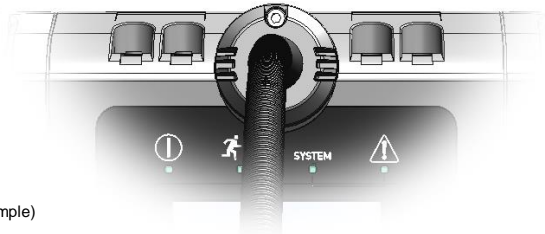

- Remove the bottom cover by undoing 2 x M4 screws (Pan Head Pozidriv, 15 mm length), and configure the microphone as required; see Figure 16 (page 17).
- Ensure that the power supply from the central equipment rack or PoE is turned off.
- Connect the field cabling from the wall socket to the microphone as required; see Figure 17 (page 18).
- If used, connect the external audio/music input and/or the speaker/headset audio output, and the contact input and/or output; see Figure 17 (page 18).

- Route the cables through the cable strain relief guides at the bottom of the microphone and re-fit the cover; see Figure 17 (page 18).

Note that a dedicated cable strain relief guide is provided for the audio input/output cables. The contact input/output cables can use the standard cable strain relief guides if required.

 If the MPS microphone is to be used as an Emergency Microphone, ensure that the unit's IP30 rating is preserved by:

- fitting any unused 3.5 mm sockets with an anti-dust cap plug (supplied) and
- fitting any unused large cable strain relief guides with a blanking sponge cord (supplied).

- Use the drilling detail drawings in Figure 10 (page 13) to fix the M0664_80 wall bracket to the wall or desk/console.

Figure 10 Wall-mounting: mounting hole and Right-Hand Side Bracket position

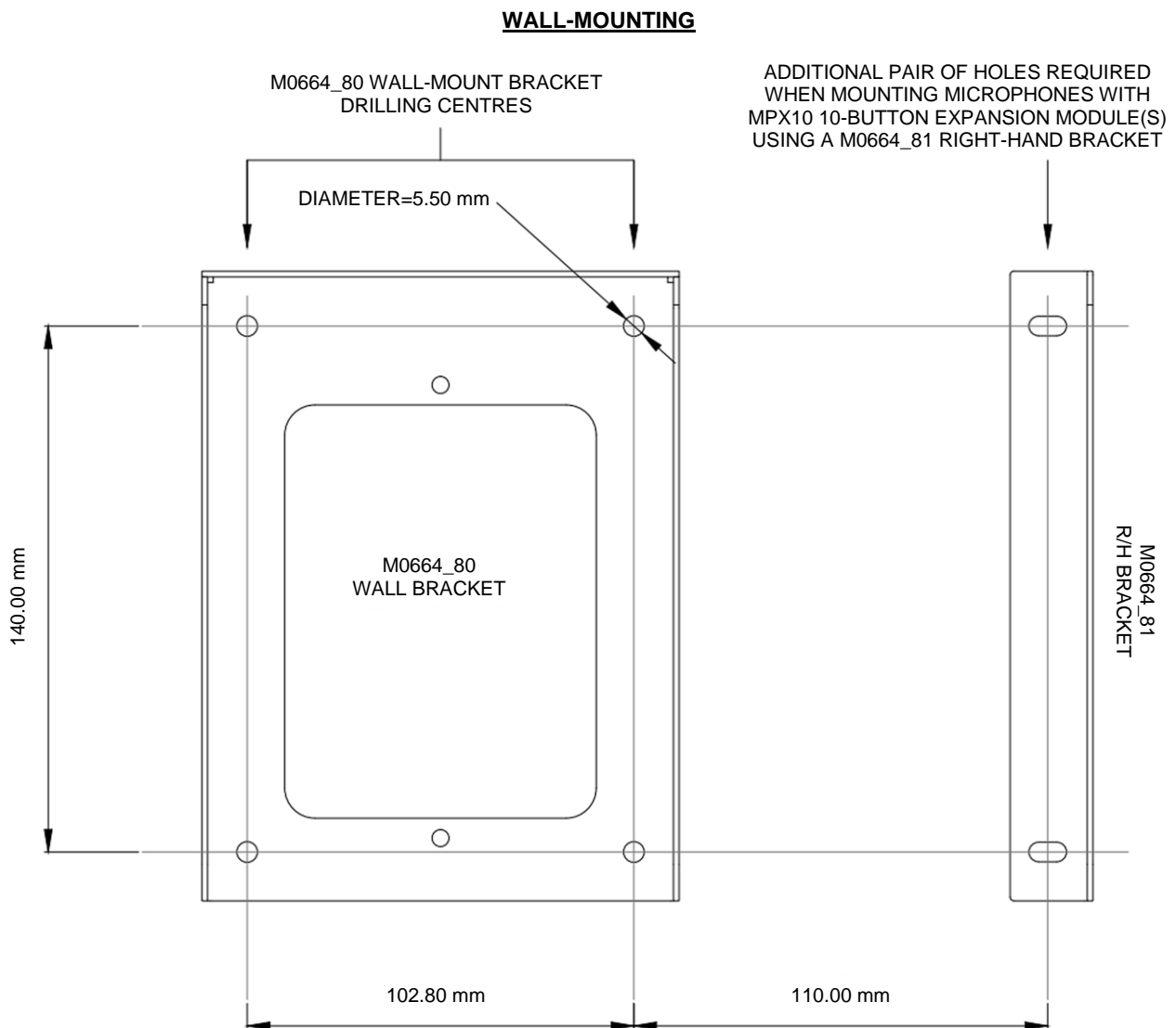

 Mount the MPS microphone at eye height for best viewing angle of the LCD display.

THIS DISTANCE IS CORRECT FOR
MOUNTING A MPS10 UNIT.
INCREASE THIS DISTANCE BY A FURTHER 110 mm FOR EACH
ADDITIONAL MPX10 10-BUTTON EXPANSION MODULE (e.g. FOR
A MPS20 THIS DISTANCE WOULD BE 220 mm)

Note that if fixing the microphone to a flat desk or console, it is suggested that the alternative drilling centres shown in Figure 11 (page 14), and that the wall bracket (and R/H bracket if used) be rotated by 180 degrees in order to impart an aesthetically pleasing slant to the mounted unit.

Figure 11 Desk/Console-mounting: mounting hole and Right-Hand Side Bracket position

DESK/CONSOLE-MOUNTING

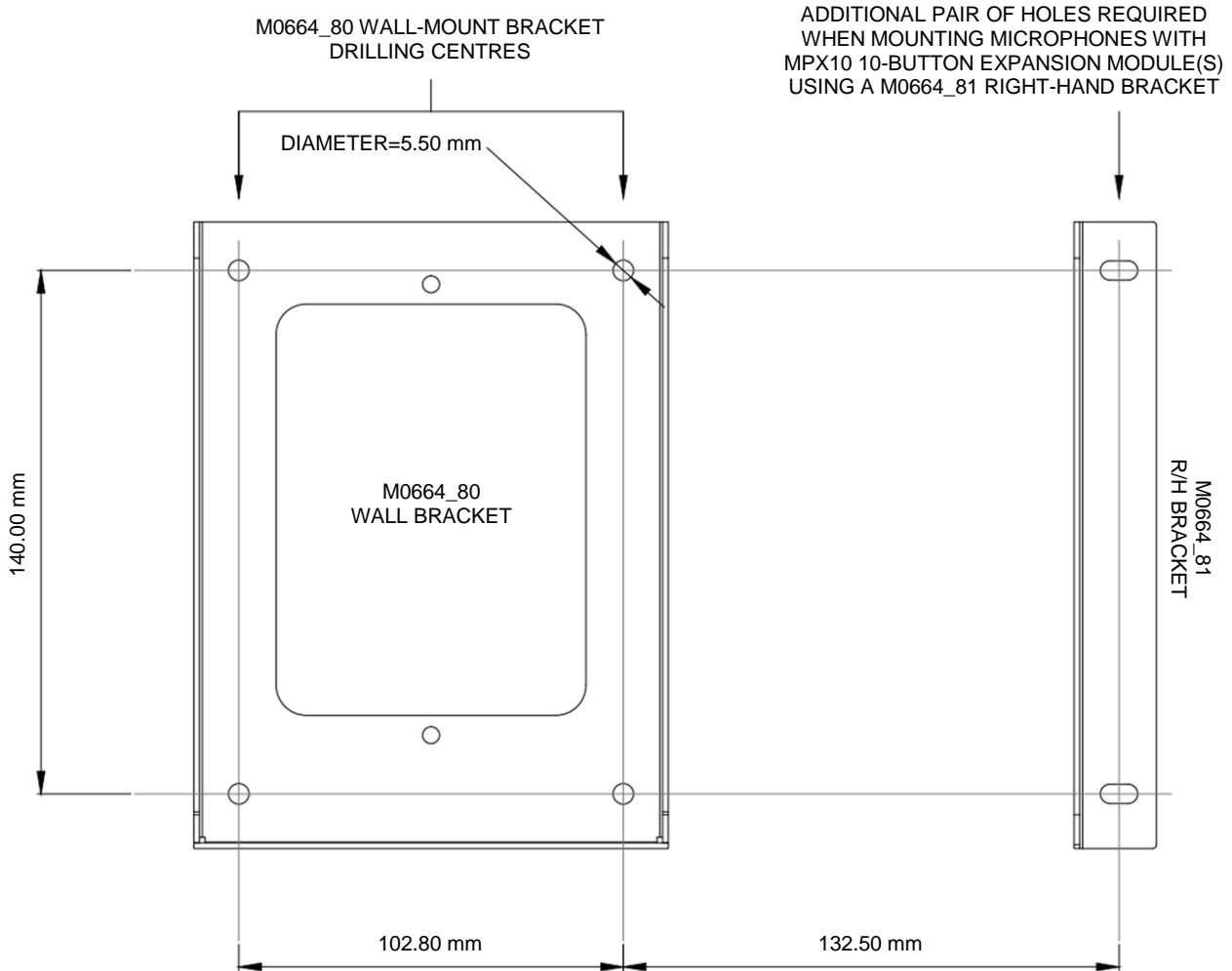

 Mount the MPS microphone at eye height for best viewing angle of the LCD display.

THIS DISTANCE IS CORRECT FOR MOUNTING A MPS10 UNIT.
INCREASE THIS DISTANCE BY A FURTHER 110 mm FOR EACH ADDITIONAL MPX10 10-BUTTON EXPANSION MODULE (e.g. FOR A MPS20 THIS DISTANCE WOULD BE 242.50 mm)

12. Offer up the microphone unit to the wall bracket and use two each of the supplied M5 hex screws and washers to fasten the microphone to the wall bracket as shown in Figure 12 (page 15).

If used, fasten the microphone to the Right-Hand Side Bracket using one M5 hex screw and washer.

Figure 12 Fastening the microphone to the wall bracket

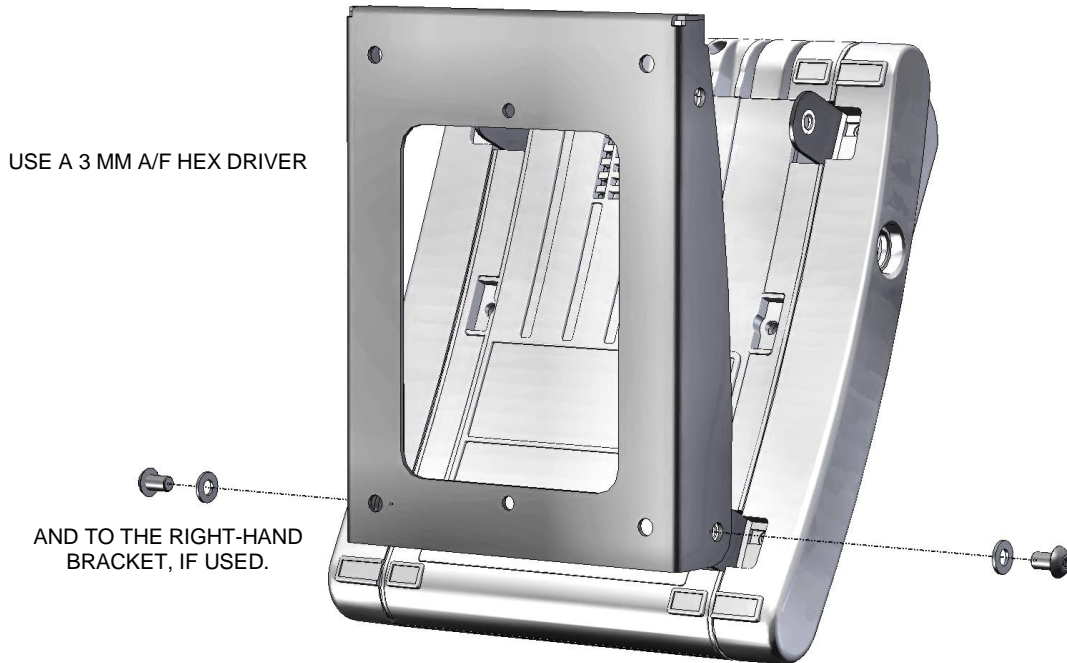

13. Use the two remaining M5 hex screws and washers to fully lock the microphone to the wall bracket; see Figure 13 (page 15).

Figure 13 Locking the microphone to the wall bracket

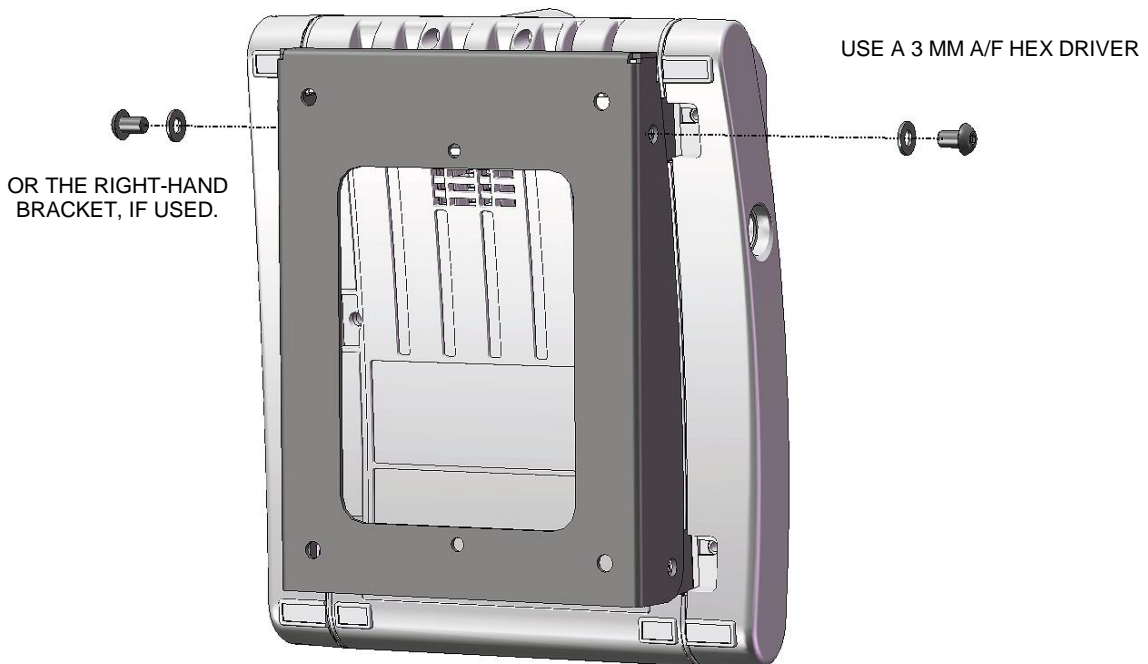

14. Fist microphone: fix the fist microphone retaining clip (supplied) to the wall next to the microphone case.
15. Gooseneck microphone: fit the foam windshield to the microphone capsule housing; see Figure 14 (page 16).

Figure 14 Fitting the foam windshield



16. If the MPS microphone is to be used as an Emergency Microphone, place the supplied pictogram label adjacent to the microphone; see example in Figure 15 (page 16).

Figure 15 Example of pictogram label

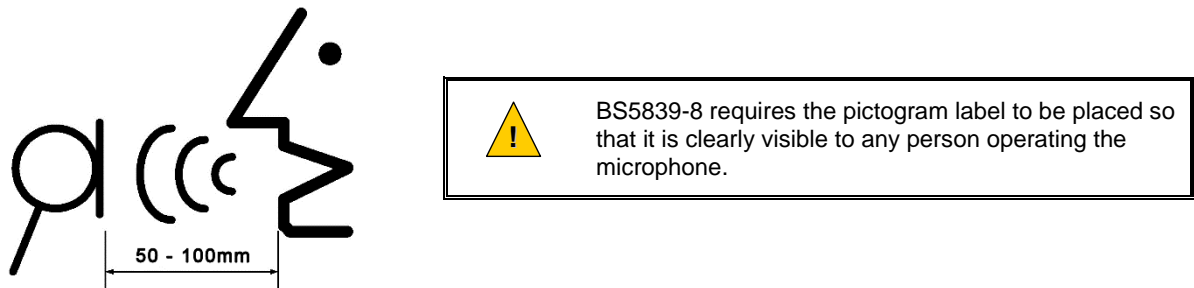

17. The installation is now complete and ready for system commissioning.

3.3.3 Microphone Settings and Build Standard

Figure 16 Removing the bottom cover and configuring the microphone

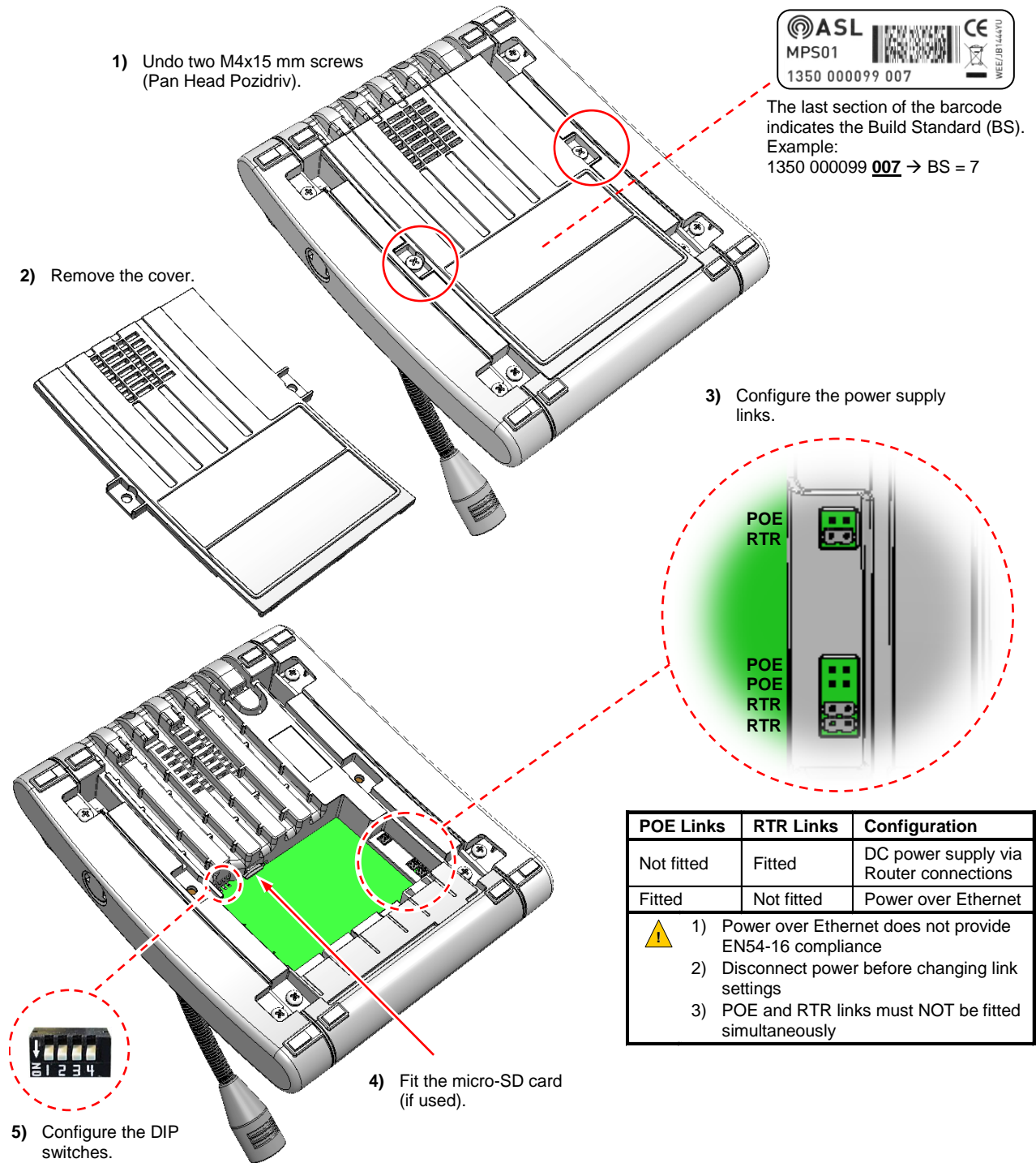

POE Links	RTR Links	Configuration
Not fitted	Fitted	DC power supply via Router connections
Fitted	Not fitted	Power over Ethernet
<p>⚠ 1) Power over Ethernet does not provide EN54-16 compliance 2) Disconnect power before changing link settings 3) POE and RTR links must NOT be fitted simultaneously</p>		

DIP Switch	SW 1	SW 2	SW 3	SW 4	Configuration
up=off down=on	DOWN	DOWN	DOWN	DOWN	Standard ASL microphone operation (default): <ul style="list-style-type: none"> • Must be used on Emergency Microphones for EN54-16 compliance • Firmware update and configuration: via the Ethernet port • Configuration via User Interface: read only
	UP	DOWN	DOWN	DOWN	Bootloader mode: for firmware update via the USB port
	DOWN	UP	DOWN	DOWN	Configuration via User Interface: read and write (for commissioning only)

4 Connections

Figure 17 MPS connections

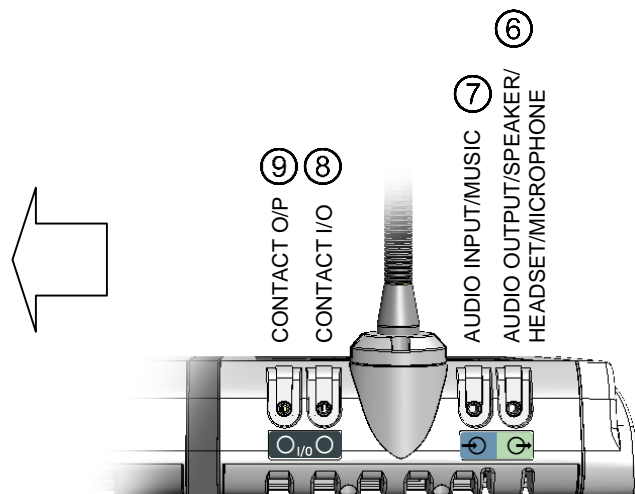
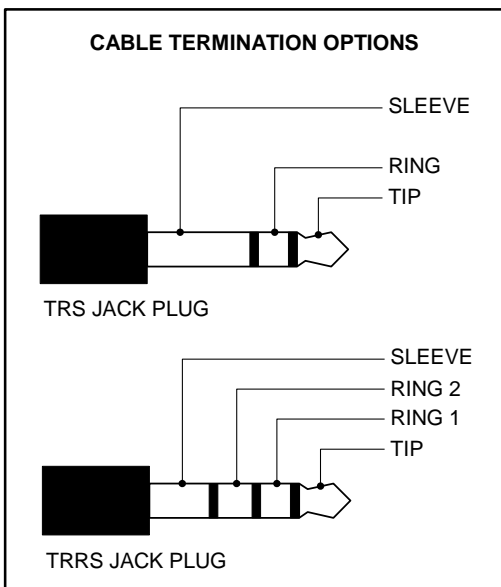
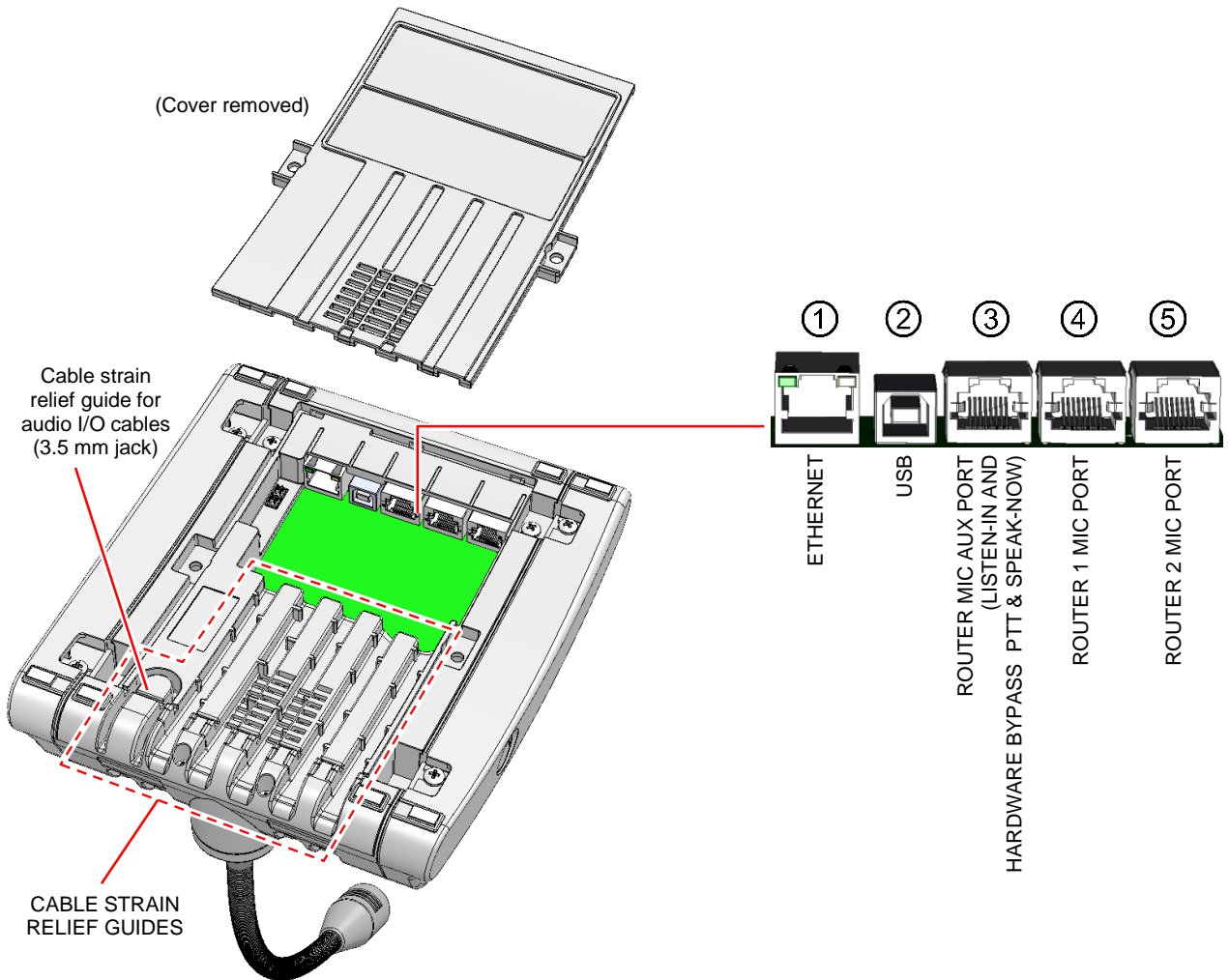

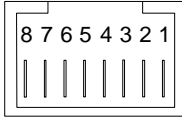
<p>①</p> <p>ETHERNET Ethernet Port</p> 	RJ45 Socket			
	Pin No.	Signal		Description
	1	TRANSMIT+	O/P	100BASE-T Ethernet
	2	TRANSMIT-	O/P	100BASE-T Ethernet
	3	RECEIVE+	I/P	100BASE-T Ethernet
	4 and 5	DC+	I/P	+V supply input (PoE: 42 – 57 V DC)
	6	RECEIVE-	I/P	100BASE-T Ethernet
	7 and 8	DC-	I/P	-V supply input (PoE: 42 – 57 V DC)
	<p>i</p> <ul style="list-style-type: none"> PoE (Power over Ethernet): see Figure 16 (page 17) for required link settings The Ethernet port can be used for digital audio I/O and for configuration purposes Ethernet and PoE connections do not provide EN 54-16 compliance ASL protocols supported over IP: ASL Serial, TRL (Transactionless) and Paging (DMS). The protocol is defined by the host (if any), and the MPS will automatically discover the protocol upon connection. 			

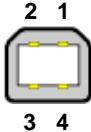
<p>②</p> <p>USB USB Port</p> 	USB Type B			
	Pin No.	Signal		Description
	1	VBUS	I/P	+V supply input
	2	D-	I/O	Negative Data Channel
	3	D+	I/O	Positive Data Channel
	4	GND	-	Ground
<p>i</p> <ul style="list-style-type: none"> USB port can be used for digital audio I/O and for configuration purposes Refer to ASL for software compatibility details 				

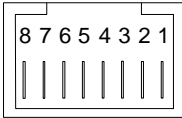
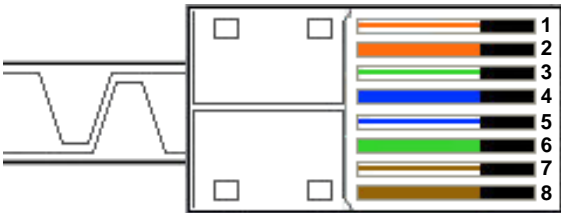
<p>③</p> <p>ROUTER MIC AUX PORT ASL Aux. Microphone Port (Listen-in and Hardware Bypass PTT+Speak-Now)</p> 	RJ45 Socket				
	Pin No.	Signal	CAT5 Cable (T568B)	Description	
	1	PTT-2+	O/P	White/Orange	Push-To-Talk switch to Router 2 (internally fitted with 6k8/470 Ω resistors)
	2	PTT-1+	O/P	Orange	Same as above, but to Router 1
	3	LISTEN-IN+	I/P	White/Green	Listen-in audio from Router (+ve / 0 dBu nominal / 10 kΩ)
	4	SPEAK NOW LED-1	I/P	Blue	Cathode of Speak Now indicators with built-in 2k2 Ω series resistor from Router 1 (anode is internally connected to 15-40 V supply)
	5	SPEAK NOW LED-2	I/P	White /Blue	Same as above, but from Router 2
	6	LISTEN-IN-	I/P	Green	Same as above Listen-in, but -ve
	7	PTT GND	I/P	White/Brown	PTT-1 or PTT-2: connection to 0 V or Router PTT-
	8	PTT GND	I/P	Brown	Same as above
	 <p style="text-align: right;">EIA 568-B</p>				
	<p>i</p> <ul style="list-style-type: none"> Used to provide hardware bypass and listen-in functions Hardware bypass is provided on inputs 1 and 2 of ASL Voice Alarm Routers Used in addition to one or both standard ASL microphone ROUTER 1 and ROUTER 2 ports below Routers with All Call LED connection: a pull up resistor (10 kΩ / 0.25 W) to +V supply is required in order to suppress the All Call LED fault 				

④ ⑤

**ROUTER 1 MIC PORT and
ROUTER 2 MIC PORT
ASL Microphone Port**

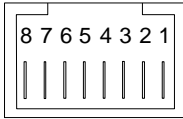

RJ45 Socket				
Pin No.	Signal		CAT5 Cable (T568B)	Description
1	AUDIO+	O/P	White/Orange	Balanced audio output (+ve / 0 dBu nominal / 220 Ω)
2	AUDIO-	O/P	Orange	Same as above, but -ve
3	DATA DXP	-	White/Green	RS485 Data+ (19200 baud)
4	+SUPPLY	I/P	Blue	+V supply input (15 to 40 V DC)
5	+SUPPLY	I/P	White /Blue	+V supply input (15 to 40 V DC)
6	DATA DXN	-	Green	RS485 Data- (19200 baud)
7	0V SUPPLY	-	White/Brown	0 V supply
8	0V SUPPLY	-	Brown	0 V supply

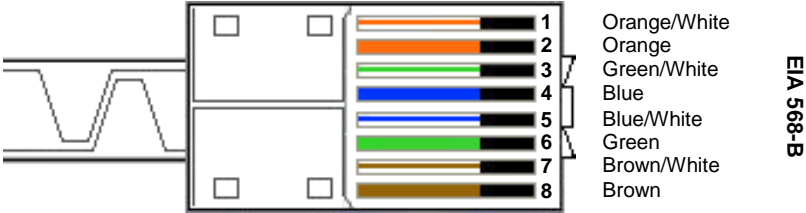

i 1) ROUTER 1 port is used for connection to the Router as standard. Use ROUTER 2 port if the MPS firmware is V1.5.20 or earlier.

2) ROUTER 2 port is used for connection to the 'B' Router in a dual interface connection with 'A' and 'B' Routers.

3) ASL protocols supported on the serial connection: ASL Serial, Paging (DMS) and Console (ACU). The protocol is defined by the host, and the MPS will automatically discover the protocol upon connection.

4) Emergency Microphones that are used as location for display of mandatory EN 54-16 indications and controls should have dual power supply: one power supply connected to ROUTER 1 port, and the other power supply to ROUTER 2 port.

5) DC power supply via Router connections: see Figure 16 (page 17) for required link settings

⑥



**Audio
Output/Speaker/Headset
Microphone**



3.5 mm socket

Plug	Contact	Signal		Description
TRRS	Tip	LEFT CHANNEL	O/P	Unbalanced stereo left channel output
	Ring 1	RIGHT CHANNEL	O/P	Unbalanced stereo right channel output
	Ring 2	GROUND	-	Ground
	Sleeve	MIC IN	I/P	Headset boom microphone input

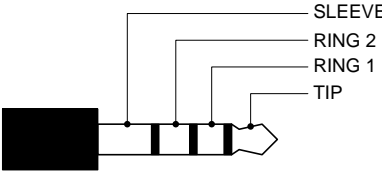





TRRS PLUG

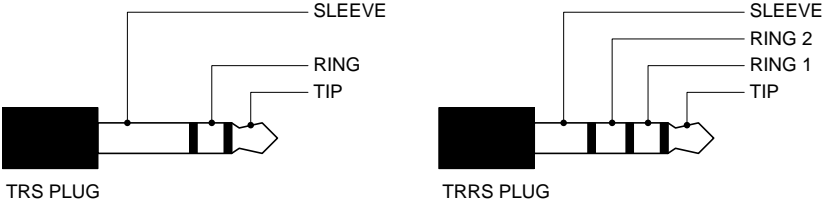

i 1) TRRS plug: a headset with boom microphone can be connected for stereo wired mono audio output plus a microphone input

2) Headset microphone should not be used in emergency mode.

3) Inserting a connector to the audio output socket will mute the built-in speaker for listen-in and message preview functions – The fault beeper will not be affected

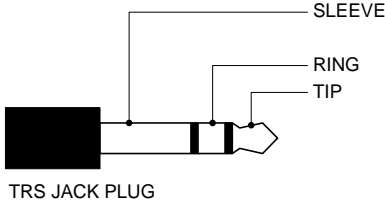
<p>⑦</p>  <p>Audio Input/Music</p>  <p>3.5 mm socket</p>	Plug	Contact	Signal	Description	
	TRS	Tip	LEFT CHANNEL	I/P	Unbalanced stereo left channel input
		Ring	RIGHT CHANNEL	I/P	Unbalanced stereo right channel input
		Sleeve	GROUND	–	Ground
	TRRS	Tip	AUDIO+	I/P	Balanced audio input +
Ring 1		–	–	–	
Ring 2		AUDIO-	I/P	Balanced audio input -	
Sleeve		GROUND	–	Ground	
					
<p>i 1) TRS plug: this input can be used for background music input (standard 3.5 mm stereo socket input internally mixed to mono)</p> <p>2) TRRS plug: this input can be used for connection of a balanced audio source</p>					

<p>⑧</p>  <p>Contact Input and Output</p>  <p>3.5 mm socket</p>	Plug	Contact	Signal	Description	
	TRS	Tip	CONTACT INPUT	I/P	Contact input (contact closure to ground, internal 10 kΩ pull up to +3.3 V)
		Ring	CONTACT OUTPUT	O/P	Contact output (open-collector)
Sleeve		GROUND	–	Ground	
					
<p>i Single contact output provided twice on two connectors</p>					

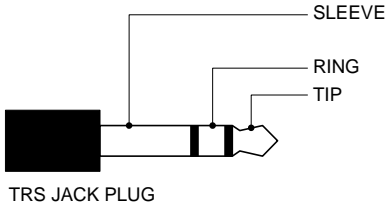
<p>⑨</p>  <p>Contact Output</p>  <p>3.5 mm socket</p>	Plug	Contact	Signal	Description	
	TRS	Tip	+5V OUTPUT	O/P	Low current supply output (50 mA max.)
		Ring	CONTACT OUTPUT	O/P	Contact output (open-collector)
Sleeve		GROUND	–	Ground	
					
<p>i 1) Single contact output provided twice on two connectors</p> <p>2) Low current supply output only available from Build Standard 4 or later</p>					

5 Mechanical Dimensions

Figure 18 MPS dimensions

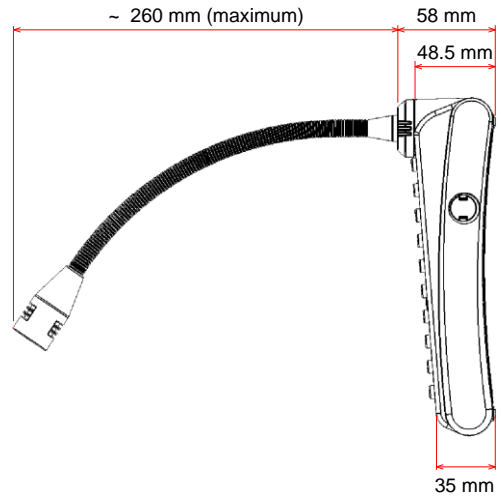
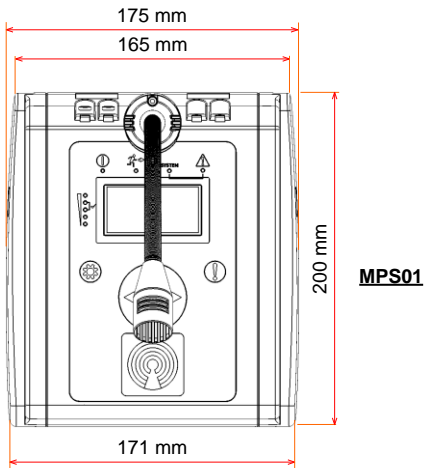

Note: Increase the width by a further 110 mm for each MPX10 Expansion Module. See examples below for MPS10 and MPS20 .

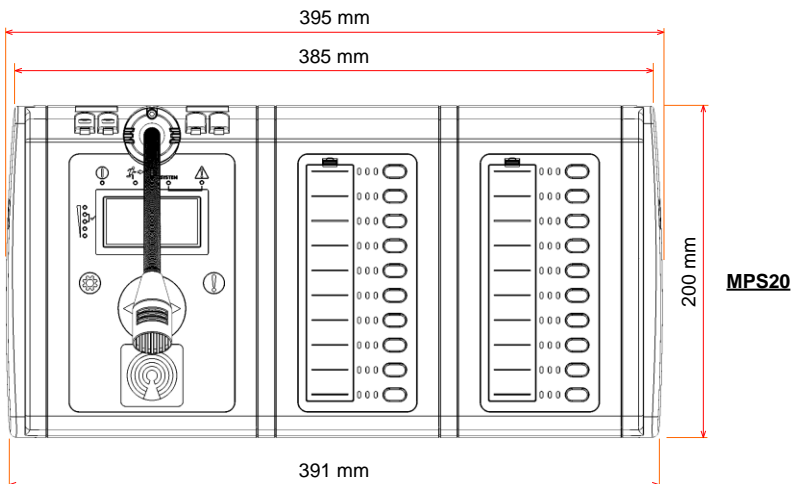
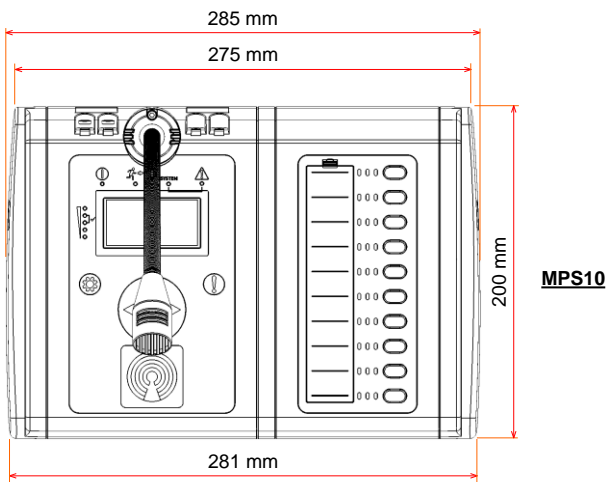

6 Safety and Precautions

Observe all safety information both on the product and in this section.

Environmental

The temperature and humidity ranges shown in the specifications for this product must not be exceeded.

This equipment must not be installed in an area that is subject to a corrosive atmosphere, excessive moisture or may allow water or other liquids to come into contact with the unit or its external connections. Objects filled with liquids such as vases should not be placed upon it.

Wall-Mount Bracket Installation



To prevent injury, the wall/desk-mount microphone must be securely attached to the wall/desk in accordance with the installation instructions.

EMC

The signal to noise ratio of this product may be reduced:

- in the vicinity of strong magnetic fields, e.g. transformers or induction loops
- in the close proximity of some radio frequency transmitters

If this occurs, re-location of the equipment or the signal cables is recommended.

Electrical Safety



Ensure power supply cabling is adequately rated.

Always replace blown fuses with the correct type and rating.

ESD Precautions

This product contains static-sensitive devices. Observe ESD precautions when working on the equipment with the cover removed.

Unpacking and Handling

The equipment should be unpacked and inspected immediately on receipt. If damage has occurred please advise your carrier or supplier.



This equipment contains electronic devices that are sensitive to electrostatic discharge. Please take precautions to avoid damage to the electronics by static electricity.

It is advisable to retain the original equipment packing in the event that the equipment ever needs returning for service.

Ensure that the name and address of the Authorised Distributor from whom you purchased the unit is recorded on the “Service and Warranty” page of this manual for future reference.

Packing for Return for Repair



All electronics assemblies must be properly packed in ESD protective packing for transport, to prevent physical and ESD damage.



The filler material used for packing for return for repair must be antistatic or static dissipative, as this may come into contact with exposed connectors, wiring, or PCB assemblies. The use of non-conductive filler material may cause damage to the electronic assemblies reducing their operational life, or even destroying them.

Advice on packing the product for return can be provided by ASL.

Service and Warranty

Name and Address of Authorised Distributor:

This product carries a full warranty. For full details of warranty and service agreements, please contact the Authorised Distributor who supplied the product to you.

Exclusions

The warranty does NOT cover:

1. Customer misuse, including incorrect installation.
2. Damage other than manufacturing defects.
3. Transit / Courier damage.
4. Incorrect voltage or power supply used.
5. Incorrect input signal.
6. Abnormal environmental operating conditions.
7. Damage incurred by accident, fire, lightning or other hazard.
8. Modification to the unit or inexpert / attempted repair.
9. No fault found – where no fault can be found after extensive testing, indicating user error or failure in ancillary equipment.
10. Electronic assemblies which are improperly packed when returned for repair or service.

Should any of the above apply, Application Solutions (Safety and Security) Limited reserves the right to raise any relevant charges to the customer.

Application Solutions (Safety and Security) Limited shall not be liable for any indirect, special or consequential loss or damage (including without limitation any loss of profits) arising from the use of this product or for any breach of this warranty.

In the interest of continual product development, Application Solutions (Safety and Security) Limited reserves the right to make changes to product specification without notice or liability.

